

IMPORTANT! In U.S. and Canada only: Have questions? ...don't go back to the store!

We appreciate your purchasing one of our many fine products. We are sure that you will be very satisfied with your selection. Although great care and effort have been taken, occasional problems may occur. To ensure prompt and correct handling of any problems, or to answer any questions, please contact our Toll-Free Customer Service Number listed below. Service will be quicker if you have your Model Number (found on carton) and assembly instructions ready when calling. PLEASE WRITE YOUR MODEL NUMBER IN THE SPACE PROVIDED ABOVE.

SAFETY INSTRUCTIONS

FAILURE TO FOLLOW THESE SAFETY INSTRUCTIONS MAY RESULT IN SERIOUS INJURY, PROPERTY DAMAGE AND VOID WARRANTY.

Owner must ensure that all players know and follow these rules for safe operation of the system.

To ensure safety, do not attempt to assemble this system without following the instructions carefully. Proper and complete assembly, use and supervision is essential for proper operation and to reduce the risk of accident or injury. A high probability of serious injury exists if this system is not installed, maintained, and operated properly. Check entire box and inside all packing material for parts and/or additional instructional material. Before beginning assembly, read the instructions and identify parts using the hardware identifier and parts list in this document.

- If using a ladder during assembly, use extreme caution.
- Two (2) people are recommended for this operation.
- Check base regularly for leakage. Slow leaks could cause system to tip over unexpectedly.
- Seat the pole sections properly (if applicable). Failure to do so could allow the pole sections to separate during play and/or transport of the system.
- Climate, corrosion or misuse could result in system failure.
- If technical assistance is required, contact Huffy Sports.
- Minimum operational height is 6'6" (1.98 m) to the bottom of backboard.
- This equipment is intended for home recreational use only and NOT excessive competitive play.
- Read and understand the warning label affixed to pole. Label is shown on page 1.
- The life of your basketball pole depends on many conditions. The climate, placement of the pole, the location of the pole, exposure to corrosives such as pesticides, herbicides or salts are all important.
- Adult supervision is recommended when adjusting height.

Most injuries are caused by misuse and/or not following instructions. Use caution when using this system.

For more information on assembly, placement, proper use and maintenance, visit The American Basketball Council website at <http://www.smarthoops.com>.

TUFF STUFF® and associated trademarks are owned and used with permission of Mattel, Inc. Huffy products are not sponsored, endorsed or authorized in any way by Mattel, Inc. or any of its affiliated or subsidiary companies.

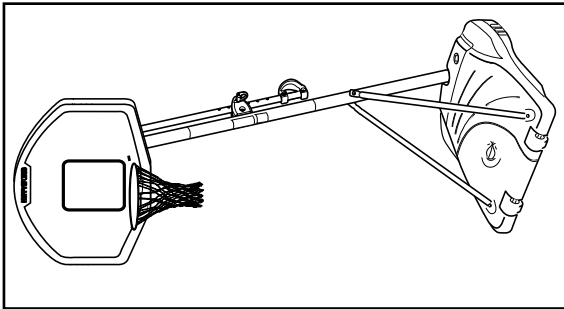

54

NOTICE TO ASSEMBLERS
ALL Huffy Sports basketball Systems, including those used for **DISPLAYS**, **MUST** be assembled and ballasted with sand or water according to instructions. Failure to follow instructions could result in **SERIOUS INJURY**. It is **NOT** acceptable to devise a makeshift weight system.

HEIGHT ADJUSTMENT

TO ADJUST BACKBOARD:

1. While holding handle, remove pin.
2. Move elevator up or down to desired height.
3. Replace pin full length to lock system at desired height.

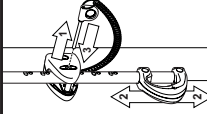

MOVING SYSTEM

1. Adjust basketball backboard height to lowest position.
2. While holding pole, rotate basketball system forward until wheels engage with ground.
3. Move basketball system to desired location.
4. Carefully rotate basketball system upright.
5. Reattach ground restraint and check system for stability.

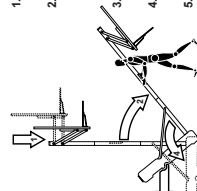

WARNING

FAILURE TO FOLLOW THESE WARNINGS MAY RESULT IN SERIOUS INJURY AND/OR PROPERTY DAMAGE.

Owner must ensure that all players know and follow these rules for safe operation of the system.

- DO NOT HANG on the rim or any part of the system including backboard, support braces or net.
- During play, especially when performing dunk type activities, keep player's face away from the backboard, rim and net. Serious injury could occur if teeth/face come in contact with backboard, rim or net.
- Do not slide, climb, shake or play on base and/or pole.
- After assembly is complete, fill system completely with water or sand and stake to the ground. Never leave system in an upright position without filling base with weight, as system may tip over causing injuries.
- When adjusting height or moving system, keep hands and fingers away from moving parts.
- Do not allow children to move or adjust system.
- During play, do not wear jewelry (rings, watches, necklaces, etc.). Objects may entangle in net.
- Surface beneath the base must be smooth and free of gravel or other sharp objects. Punctures cause leakage and could cause system to tip over.
- Keep organic material away from pole base. Grass, litter, etc. could cause corrosion and/or deterioration.
- Check pole system for signs of corrosion (rust, pitting, chipping) and repaint with exterior enamel paint. If rust has penetrated through the steel anywhere, replace pole immediately.
- Check system before each use for proper ballast, loose hardware, excessive wear and signs corrosion and repair before use.
- Check system before each use for instability.
- Do not use system during windy and/or severe weather conditions; system may tip over. Place system in the storage position and/or in an area protected from the wind and free from personal property and/or overhead wires.
- Never play on damaged equipment.
- See instruction manual for proper installation and maintenance.
- When moving system, use caution to keep mechanism from shifting.
- Keep pole top covered with cap at all times.
- Do not allow water in tank to freeze. During sub-freezing weather add non-toxic antifreeze, sand or empty tank completely and store. (Do not use salt.)
- Use extreme caution if placing system on sloped surface. System may tip over more easily.

HUFFY® SPORTS

In the U.S.: 1-800-558-5234 and Canada: 1-800-284-8339

2012/21

The NBA and individual NBA member team identifications reproduced on this product are trademarks and copyrighted designs, and/or other forms of intellectual property, that are the exclusive property of NBA Properties, Inc. and the respective NBA member teams and may not be used, in whole or in part, without the written consent of NBA Properties, Inc.

Toll-Free Customer Service Number for U.S.: 1-800-558-5234, For Canada: 1-800-284-8339, For Europe: 00 800 555 85234 (Sweden: 009 555 85234), For Australia: 1-800-333 061 - Internet Address: <http://www.huffysports.com>

HARDWARE IDENTIFIER (BOLTS)

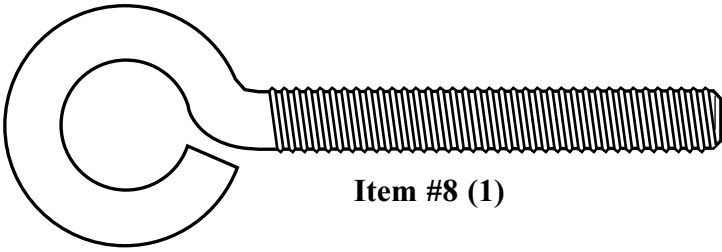

Item #8 (1)

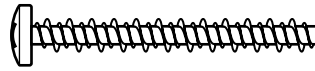

Item #31 (1)

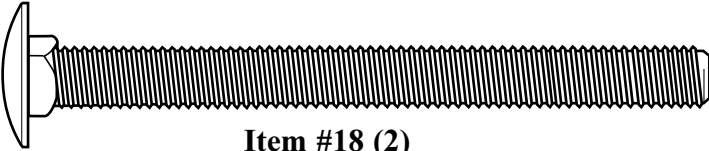

Item #18 (2)

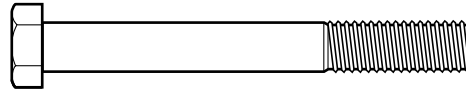

Item #37 (1)

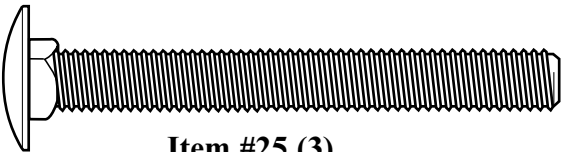

Item #25 (3)

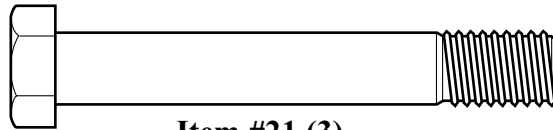

Item #21 (3)

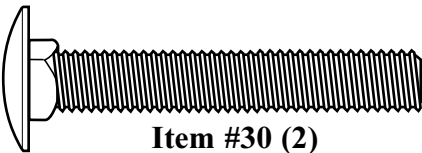

Item #30 (2)

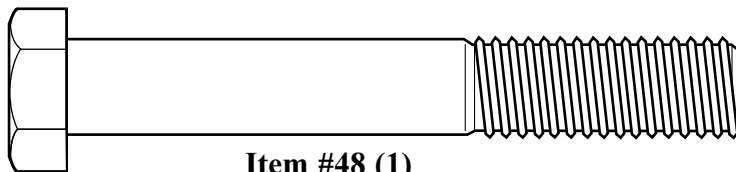

Item #48 (1)

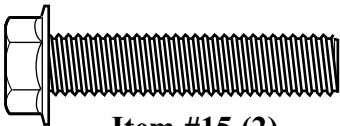

Item #15 (2)

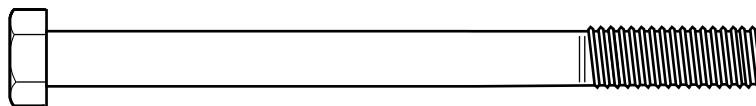

Item #14 (1)

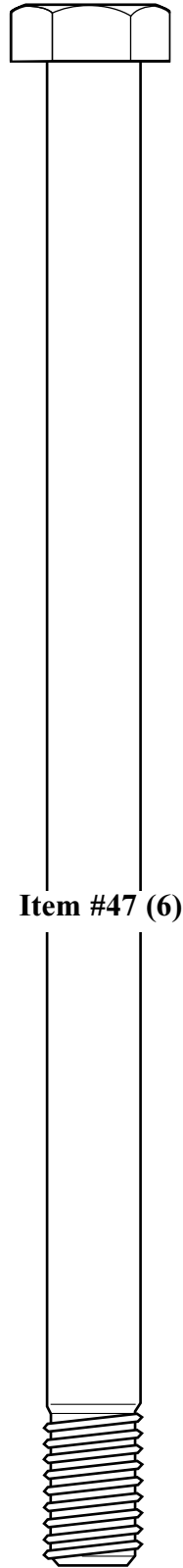

Item #47 (6)

* You may have extra parts with this model

HARDWARE IDENTIFIER (NUTS & WASHERS)

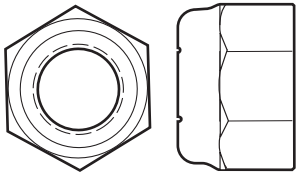

Item #39 (7)

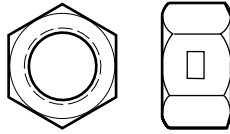

Item #20 (3)

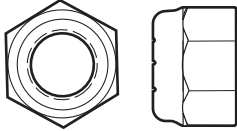

Item #10 (1)

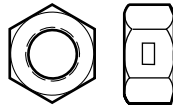

Item #35 (1)

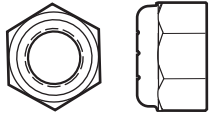

Item #12 (1)

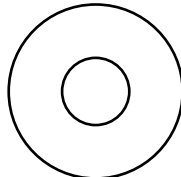

Item #13 (7)

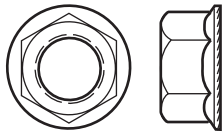

Item #16 (11)

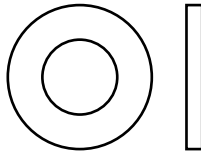

Item #19 (4)

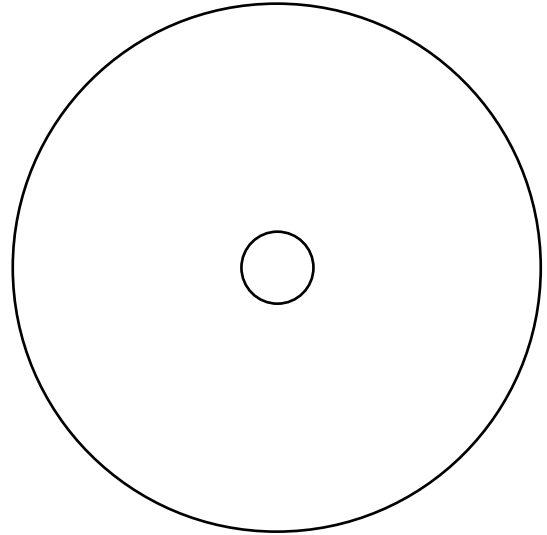

Item #9 (1)

HARDWARE IDENTIFIER (STEEL SPACERS & RODS)



Item #36 (2)

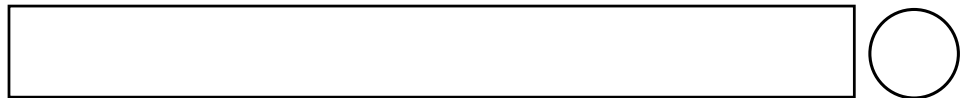

Item #2 (2)



Item #23 (2)

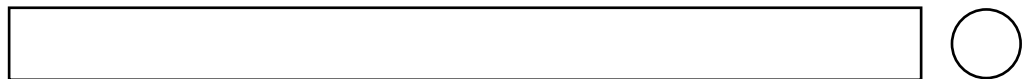

Item #7 (1)

HARDWARE IDENTIFIER (PLASTIC SPACERS & CLIPS)

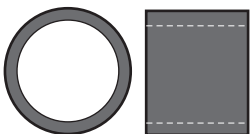

Item #38 (6)

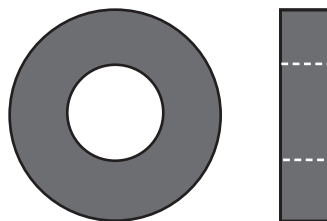

Item #44 (4)



Item #50 (12)

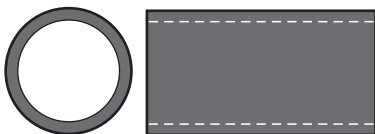

Item #55 (6)

* You may have extra parts with this model.

PARTS LIST - See Hardware Identifier

Item Qty. Part No. Description

1	1	206336	Tank, (Gray)
2	2	206330	Wheel Axle, 4-1/4 Long
3	2	226401	Wheel, 4 " (Black)
4	1	904847	Top Pole Section
5	1	908481	Middle Pole Section
6	1	908487	Bottom Pole Section
7	1	202820	Rod, 3/8 O.D. x 4-3/4 Long
8	1	202822	Eyebolt, 3/8-16 x 3-3/4 Long
9	1	202821	Disk, 2-3/4 Diameter
10	1	203063	Nylon Insert Lock Nut, 3/8-16
11	2	906410	Strut, 1" O.D. x 43 Long
12	1	203220	Nut, Nylock, 5/16-18
13	7	203218	Washer, 5/16 Flat
14	1	201625	Bolt, Yellow Dichromate, 5/16-18 X 3.60 Long
15	2	203798	Bolt, Hex Flange, 5/16-18 x 1-1/2 Long
16	11	203100	Hex Flange Nut 5/16-18
17	1	204832	Bracket, Pole Mount
18	2	203231	Carriage Bolt, 5/16-18 x 3-1/2 Long
19	4	220154	Washer, metal, 3/4" O.D.
20	3	201124	Locknut, Hex Head, 3/8-16
21	3	206360	Bolt, Hex Head, 3/8-16 x 2-5/8 Long
22	2	204858	Spacer, Biscut, plastic
23	2	204857	Spacer, metal 1/2" O.D. x 1.44 Long
24	2	204859	Cover, Spring
25	3	203038	Carriage Bolt, 5/16-18 x 2-3/4 Long
26	1	204850	Pin, Locking
27	1	204853	Lanyard, Black Coil
28	1	904833	Height Adjustment Rod
29	1	204872	Label, Height Indicator
30	2	203103	Carriage Bolt, 5/16-18 x 2 Long
31	1	204803	Screw, Phillips Head
32	1	204855	Handle, Left
33	1	204856	Handle, Right
34	2	900846	Board Bracket
35	1	203493	Nut, 1/4-20, Center Lock
36	2	201129	Spacer, .402 I.D. x .5 O.D. x 1.8 Long
37	1	240017	Bolt, Hex Head, 1/4-20 x 2-1/4 Long
38	6	206311	Spacer, Plastic, .530 I.D. x .50 Long
39	7	206340	Locknut, Hex Head, 1/2-13
40	2	904820	Elevator Tube, Lower-Long
41	1	204838	Spring
42	1		Rim
43	2	904808	Elevator Tube, Upper-Short
44	4	201651	Spacer, 1/4 Long x 1/2 O.D.
45	2	900867	Plate, Triangle, (Black)
46	1	202814	Cap, Pole Top
47	6	206244	Bolt, Hex, 1/2-13 x 8 Long
48	1	204870	Bolt, Hex, 1/2-13 x 3-1/2 Long
49	2	203617	Plug Cap
50	12	201219	Smart Clip, Net Holder,
51	1		Net
52	1	201568	Anchor, T-Strap
53	1	203124	Stake, Tie Down
54	1	201252	Label, Height Adjustment and Moving
55	6	202862	Spacer .563 I.D. x 1.19 Long

WARRANTY CARD:

Please remember to complete your product registration form either on-line at: www.huffysports.com/warrantycard or mail-in the enclosed postcard.

* You may have extra parts with this model.

BEFORE YOU START!

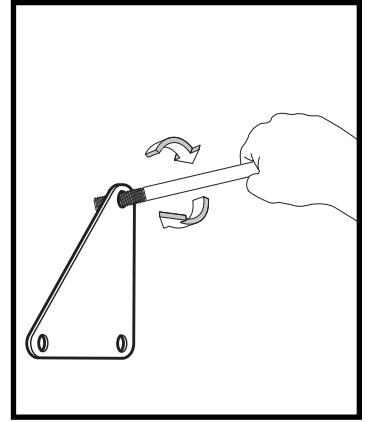
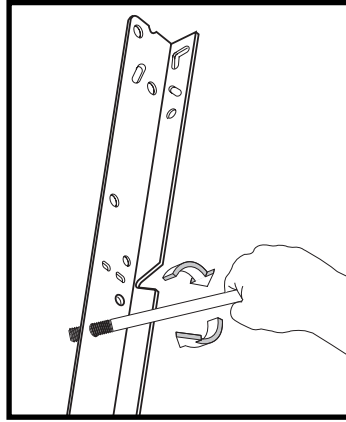
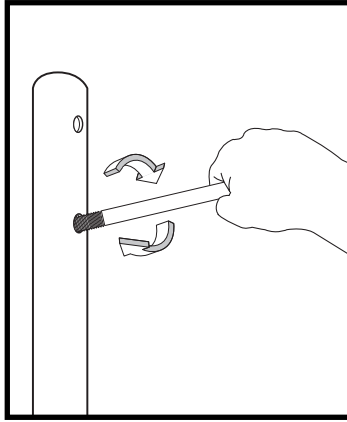

To ensure optimal playability of backboard system, a close tolerance fit between the elevator components and hardware is required. Test fit large bolts into large holes of elevator tubes, backboard brackets and triangle plates. Carefully rock them in a circular motion to ream out any excess paint from holes if necessary.

ENGLISH INSTRUCTIONS

IMPORTANT! WRITE MODEL NUMBER FROM BOX ONTO PAGE 1 OF THIS OWNERS MANUAL

1. Remove all contents from underside of tank. Keep tank (1) bottom side up.
2. Insert axle rod (2) through wheel (3), as shown. Secure wheel assembly to tank (1) by tapping wheel downward with hammer, snapping it into position. Repeat for opposite side, then carefully, turn tank (1) over.
3. Mark pole sections with tape as shown.
4. **IMPORTANT! Center alignment slot of middle pole section (5) in a lower hole of top pole section (4) as shown.** While maintaining alignment, bounce pole top (4) and middle section (5) together as shown until they no longer move toward taped reference mark. Upright assembly. **NOTE:** Pole sections should have a 3-1/2" (9 cm) minimum overlap.
5. **IMPORTANT! Center alignment slot of lower pole section (6) in a lower hole of middle pole section (5) as in step 4.** While maintaining alignment, bounce assembly and lower section (6) together as shown until they no longer move toward taped reference mark. **NOTE:** Pole sections should have a 3-1/2" (9 cm) minimum overlap.
6. Install rod (7) through holes in bottom pole section (6) and eyebolt (8).
7. Insert pole assembly into tank assembly as shown.
8. Carefully place unit on its side. Secure pole bottom (6) to tank with anchor strap (52), washers (9 & 13) and nut (10) as shown. Upright unit. **NOTE:** Keep unnecessary pressure off of the pole assembly when in this position. Two people recommended for this procedure. **IMPORTANT! Do not over tighten, will crack tank.**
9. Secure strut tubes (11) to bottom pole section (6) as shown.
 - ▲ **WARNING: TIGHTEN BOLT (14) IN LOCKNUT (12) UNTIL FLUSH (EVEN) WITH LOCKNUT'S OUTER EDGE.**
10. Once again, carefully place unit in the side position and secure strut (11) to tank (1) as shown. Completely tighten. Repeat for opposite side. Upright unit. **NOTE:** Keep unnecessary pressure off of the pole assembly when in this position. Two people recommended for this procedure.
11. Install pole mount (17) bracket with carriage bolts (18) as shown. Tighten flange nuts (16) completely.
12. Attach spacers (22, 23) to pole mount bracket (17) with bolts (21), washers (19), and nuts (20) as shown. **IMPORTANT! Tighten until washers (19) no longer move.**
13. Attach covers (24) onto pole mount bracket (17) with carriage bolt (25) and nut (16) as shown.
 - IMPORTANT: Loop end of pin lanyard (27) over carriage bolt (25) during this assembly. NOTE:** Assemble lanyard (27) to locking pin (26) as shown.
14. Apply logo and height indicator labels (29) to adjustment rod (28) as shown. Attach handle parts (32, 33) to adjustment rod with screw (31), carriage bolt (30), and flange nut (16) as shown. **IMPORTANT: Indicator labels should be applied as close to holes as possible to prevent labels from being damaged during height adjustment. NOTE:** Holes in adjustment rod allow for either rear access or side access.
15. Insert handle assembly through pole mount assembly as shown. Lock pole assembly in place at the 10' (3.05 m) mark with pin (26).
 - 16. Install spacers (36) onto backboard brackets (34) with bolts (37, 21) and lock-nuts (35, 20) as shown.
 - 17. Assemble lower elevator tubes (40) as shown.
 - IMPORTANT! It is necessary for all parts to be installed for this mechanism to work safely and properly. NOTE:** Test fit bolts into holes of brackets (34) and carefully rock them in a circular motion to ream out paint from holes if necessary.
 - 18. Starting with nuts (16) flush against bracket (34), secure rim (42) and bracket to backboard. **IMPORTANT! For spring loaded rim assembly, refer to instructions included with rim hardware. NOTE A:** Do not use washers here on spring return style rim. **NOTE B:** Mounting nuts and bolts supplied with rim hardware.
 - 19. Bend bracket (34) to line up with holes in backboard and secure.
 - 20. Assemble upper elevator tubes (43) to backboard brackets (34).
 - 21. Support pole on sawhorse. Attach backboard assembly to top pole section (4) as shown. Then install pole cap (46). **NOTE:** Two people are recommended for this step. Use caution; elevator assembly is heavy.
 - 22. Install upper elevator tubes (43) to triangle plates (45) as shown.
 - 23. Install handle assembly to lower elevator tubes (40) using bolt (47), spacers (38, 55), and nut (39) as shown. **NOTE:** Before going on to next step, set adjustable system assembly to the 10' (3.05 m) setting.
 - 24. Insert bolt (47) through left side upper elevator tube (43), then stretch spring (41) onto bolt (47). Insert bolt (47) through right side upper elevator tube (43) and secure with nut (39).
 - ▲ **WARNING: USE EYE PROTECTION WHEN INSTALLING SPRINGS.**
 - 25. Roll completed assembly to desired playing area. Secure assembly to ground using anchor strap (52) and tie down stake (53). Fill tank with water (approx. 30 gallons (115 Liters)) or sand (approx. 255 lbs. (113 kg)) and snap cap (49) in place. **IMPORTANT! Add two gallons (7.6 Liters) of non-toxic antifreeze in sub-freezing climates.**
 - ▲ **WARNING: DO NOT LEAVE ASSEMBLY UNATTENDED WHEN EMPTY, MAY TIP OVER.**
 - 26. While holding handle, remove pin (26).
 - ▲ **WARNING: DO NOT ALLOW CHILDREN TO ADJUST HEIGHT.**
 - 27. Move elevator up or down to desired height.
 - 28. Replace pin (26) full length to lock system at desired height.
 - 29. Apply height and transport label (54) to front of pole as shown. Regulation rim height is 10 feet (3.05m).
 - ▲ **WARNING: USE OF THIS PRODUCT WITHOUT PROPER INSTALLATION OF SMART CLIPS, OR WHEN ALL SMART CLIPS ARE NOT PRESENT COULD RESULT IN BODILY HARM. BE SURE TO FOLLOW DIRECTIONS CAREFULLY.**
30. Install net clips as shown. (See illustration)
31. Install net as shown. (See illustration)

1.

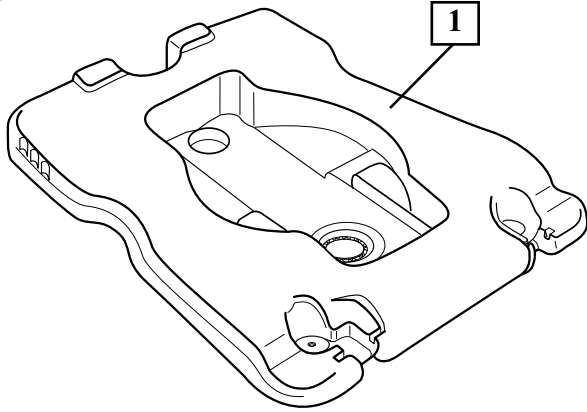

2.

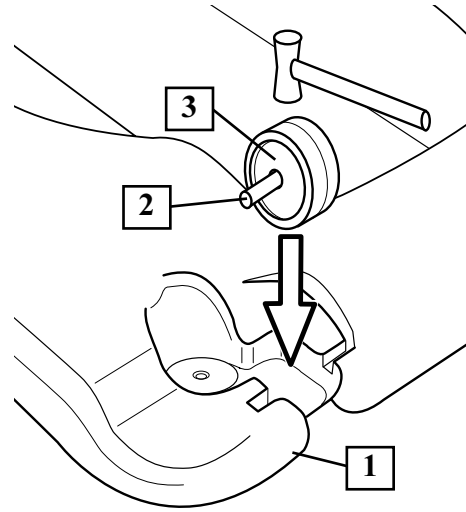

3.

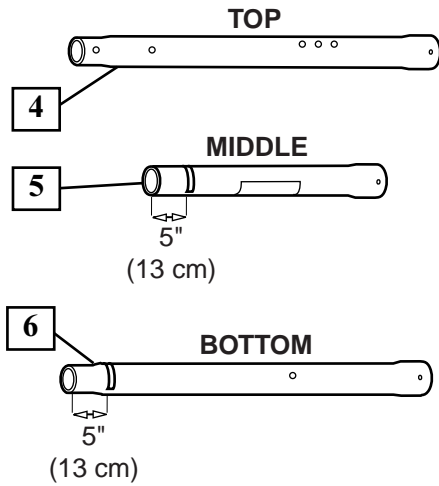

4.

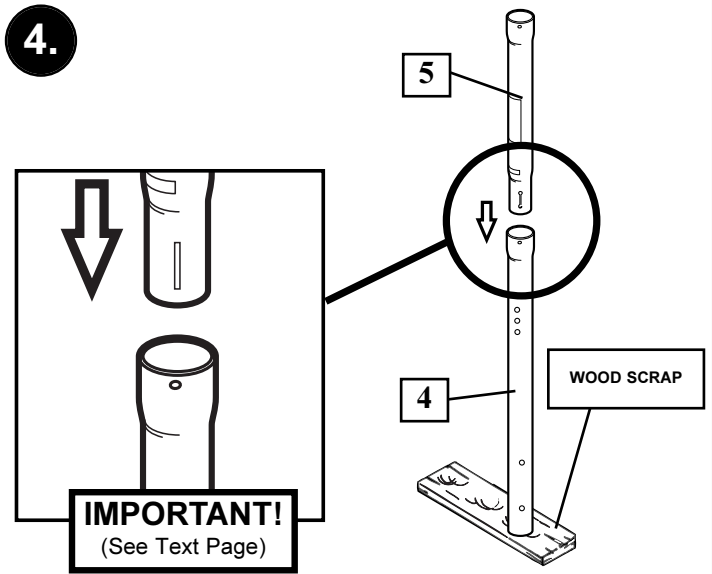

5.

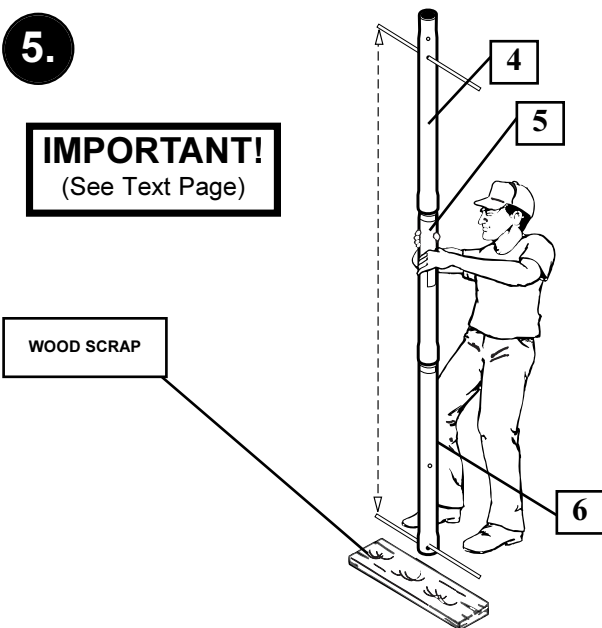

6.

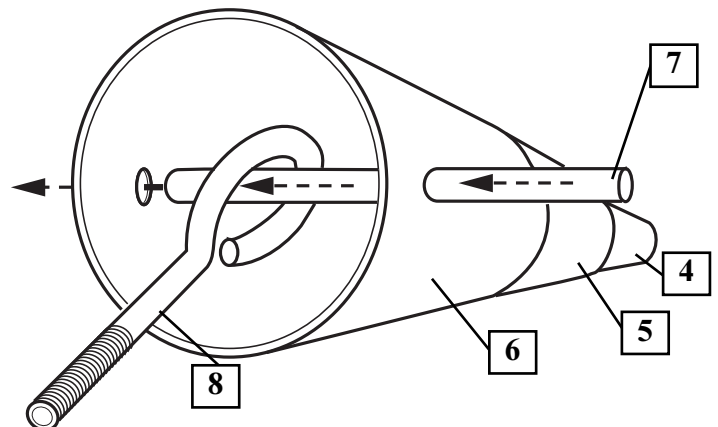

7.

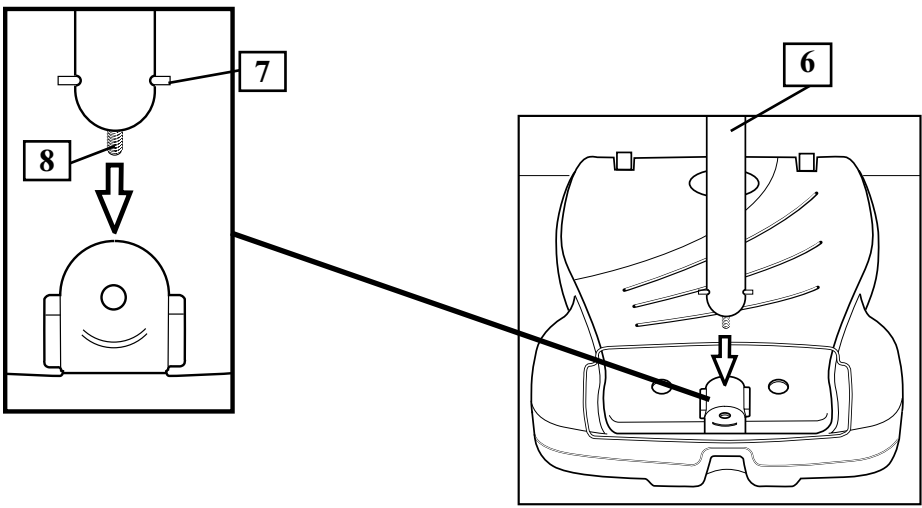

8.

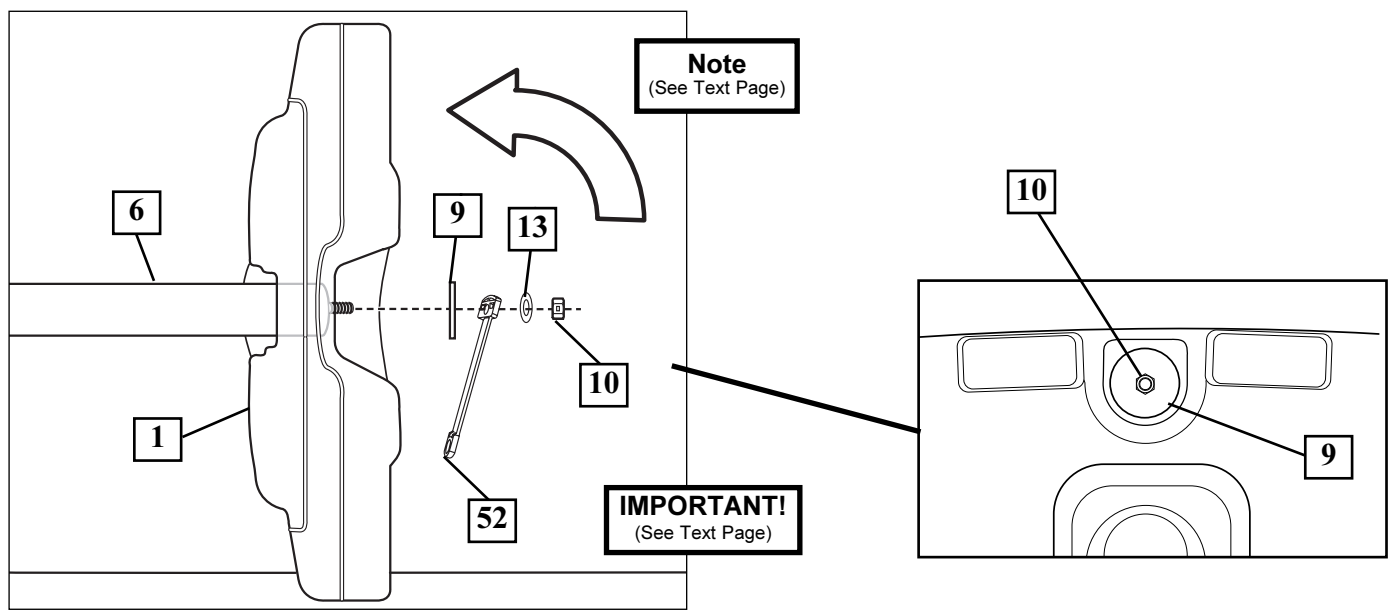

9.

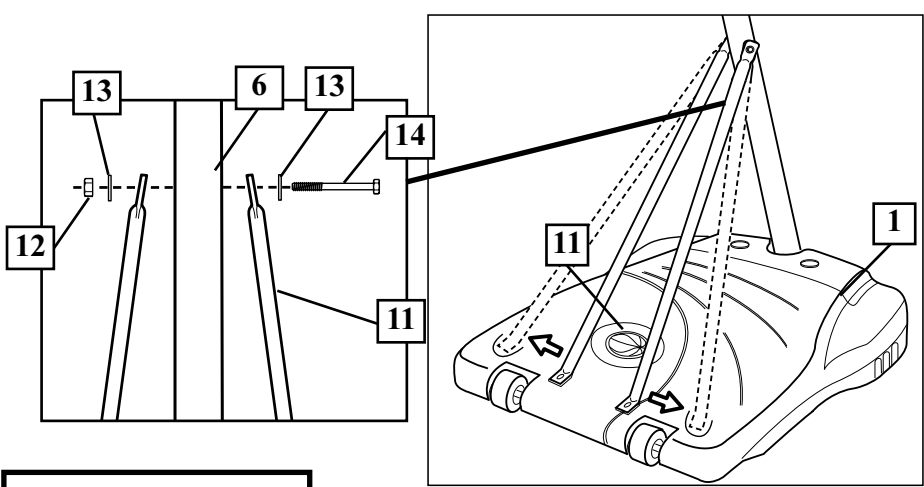

⚠ WARNING
(See Text Page)

10.

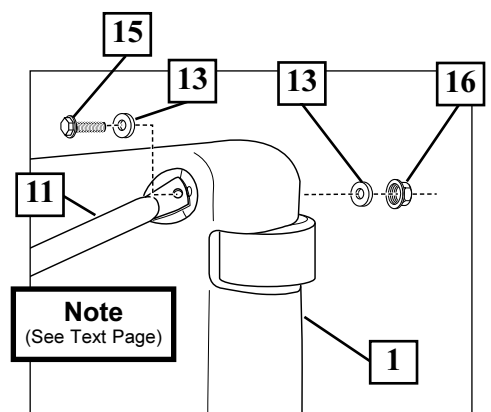

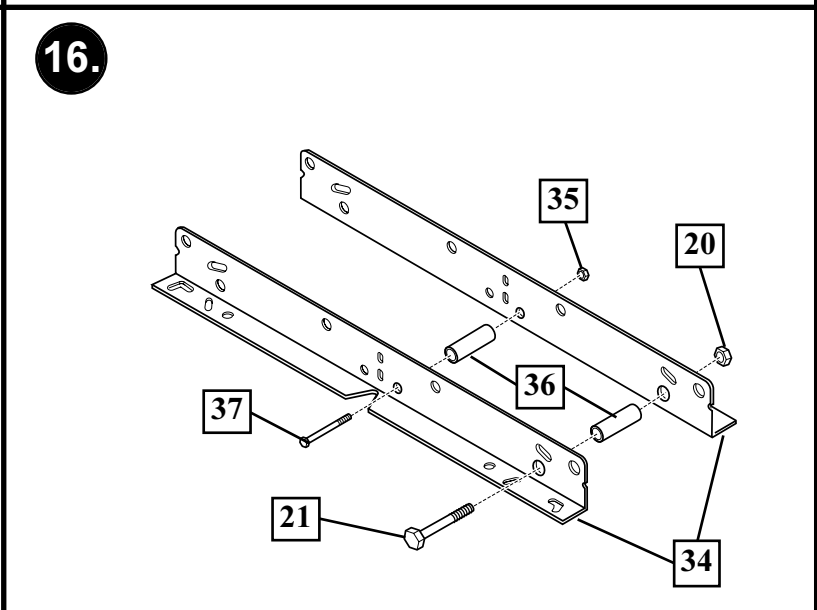
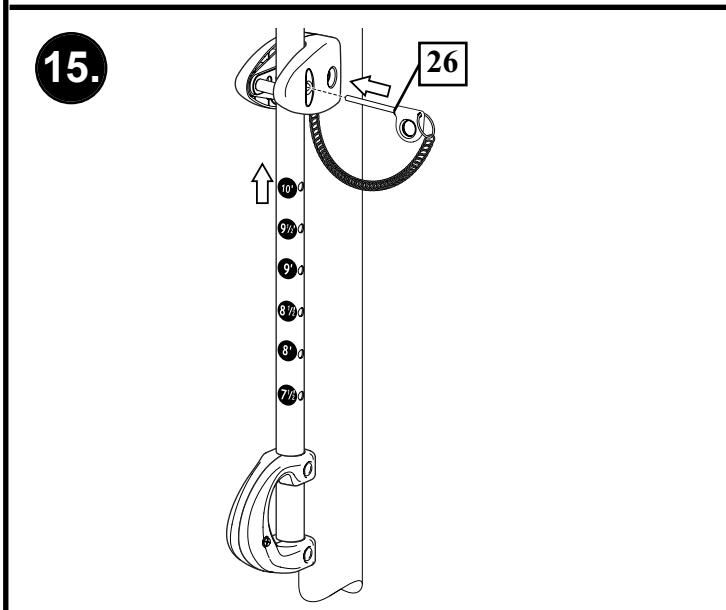
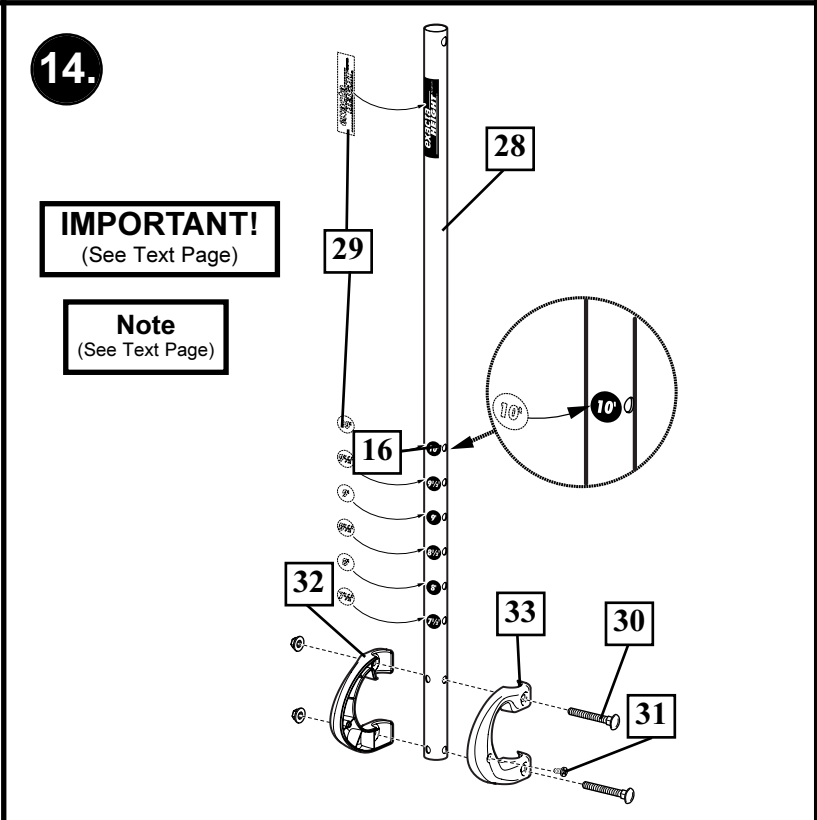
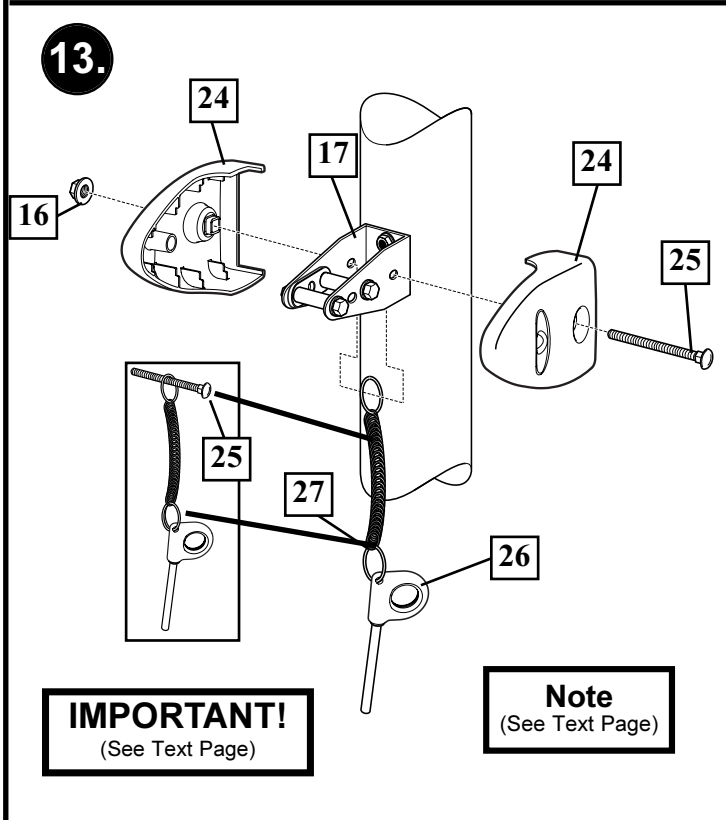
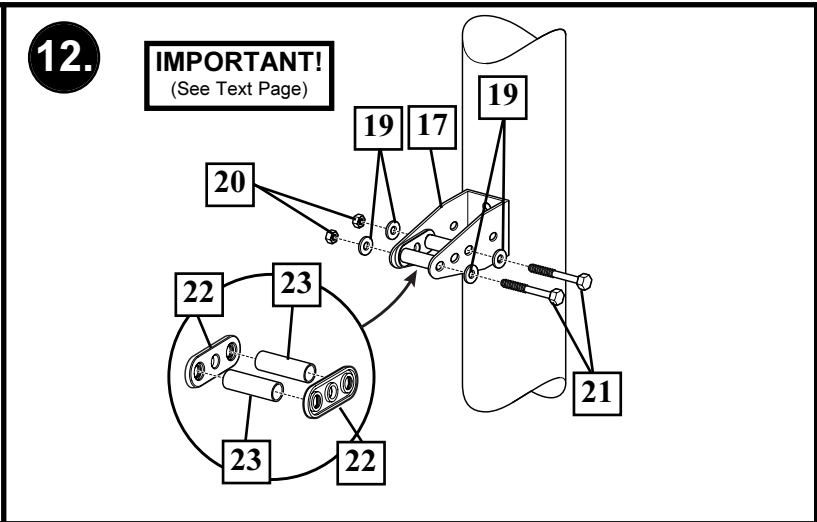
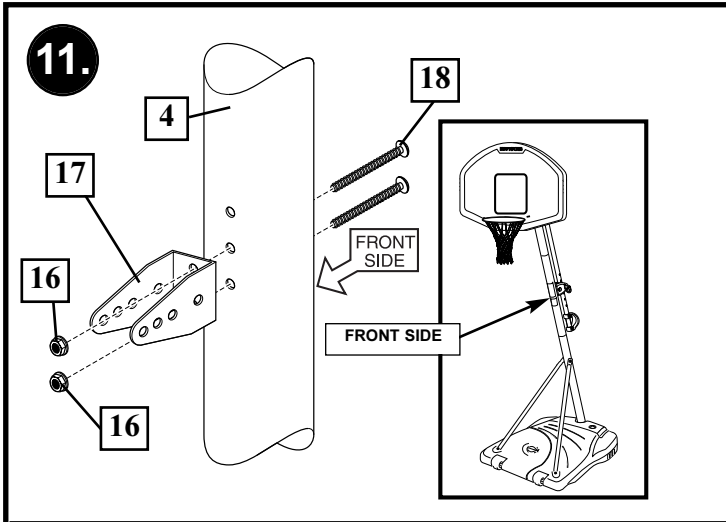

17.

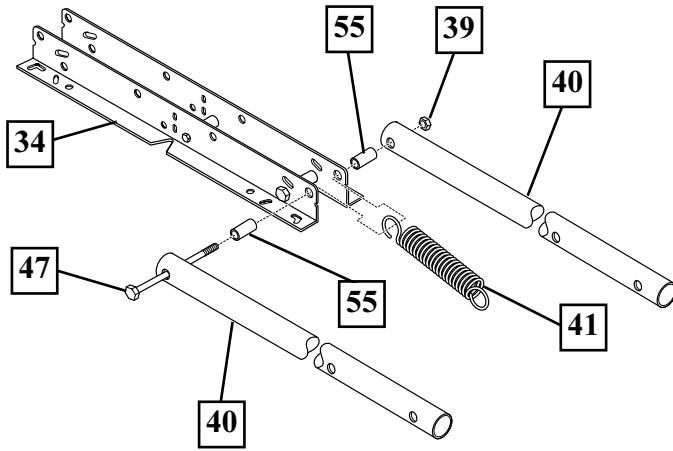

IMPORTANT!
(See Text Page)

Note
(See Text Page)

18.

19.

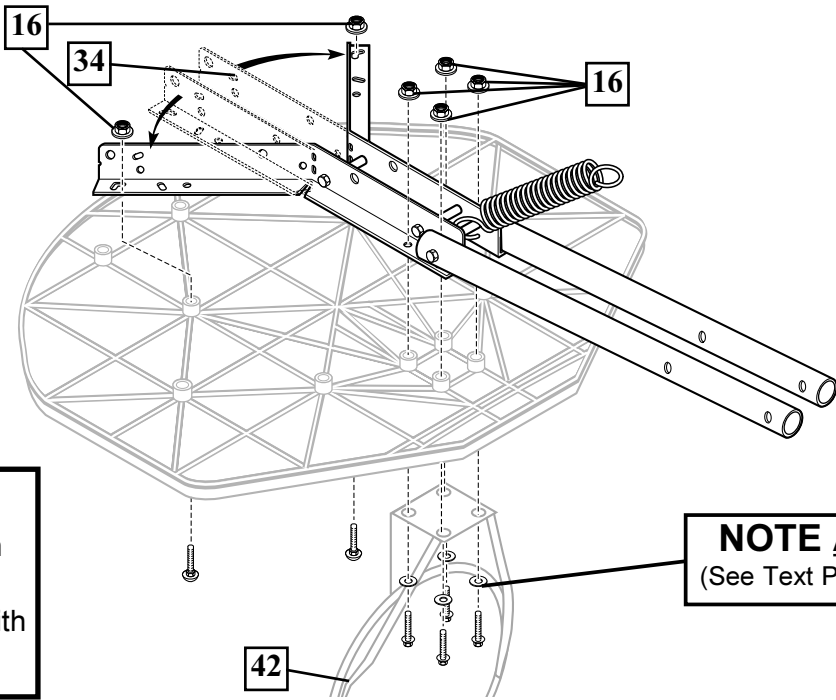

NOTE B:
(See Text Page)

IMPORTANT!
For spring loaded rim
assembly, refer to
instructions included with
rim hardware.

NOTE A:
(See Text Page)

20.

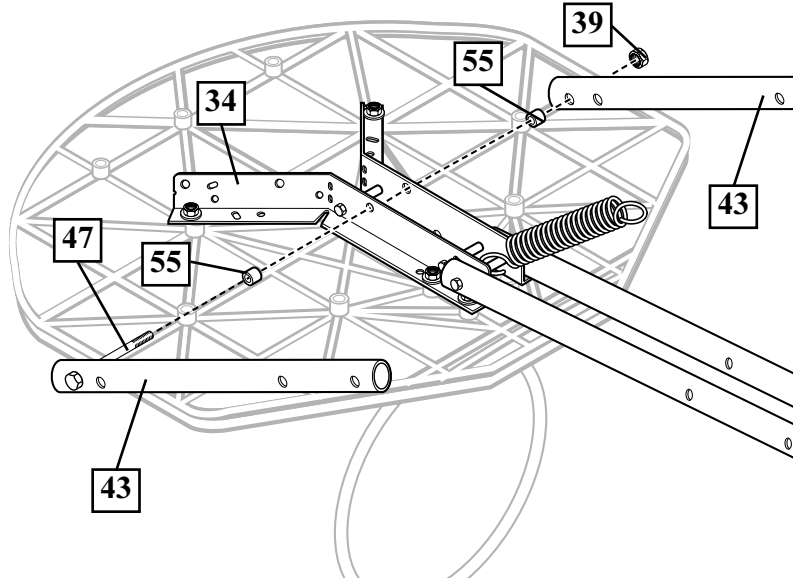

21.

Note
(See Text Page)

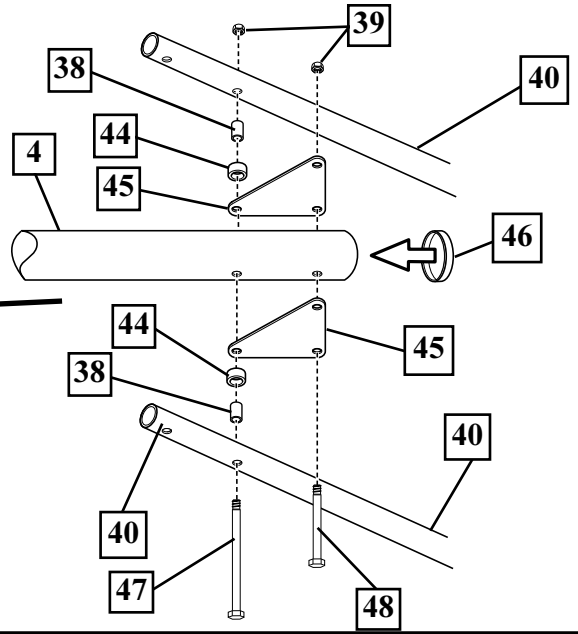
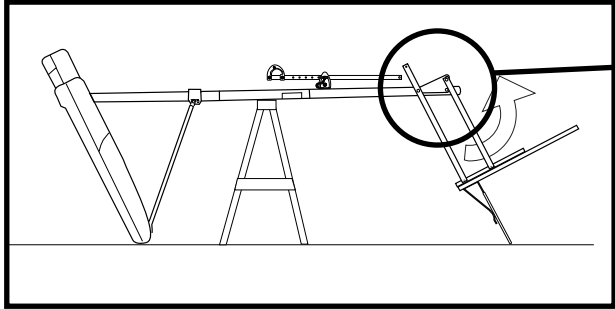

22.

23.

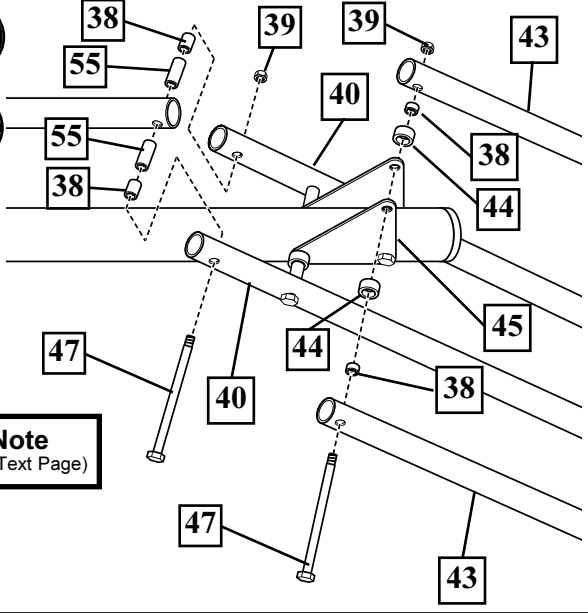

Note
(See Text Page)

24.

WARNING
(See Text Page)

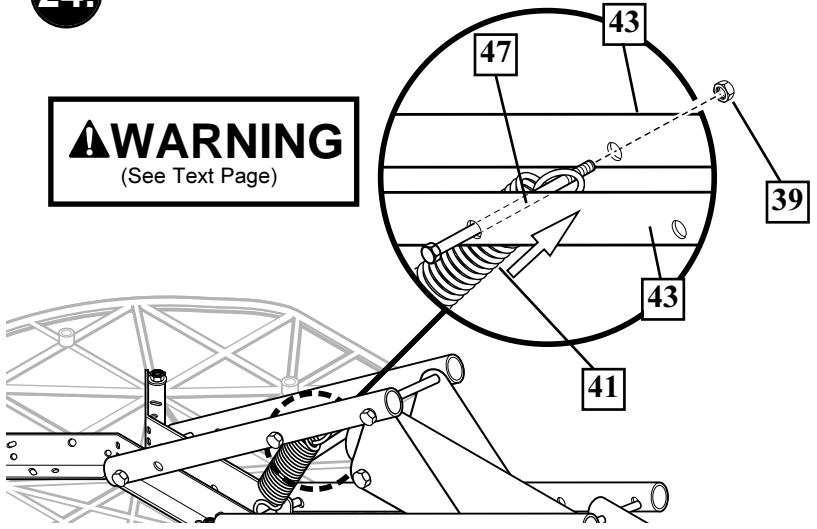

25.

WARNING
(See Text Page)

IMPORTANT!
(See Text Page)

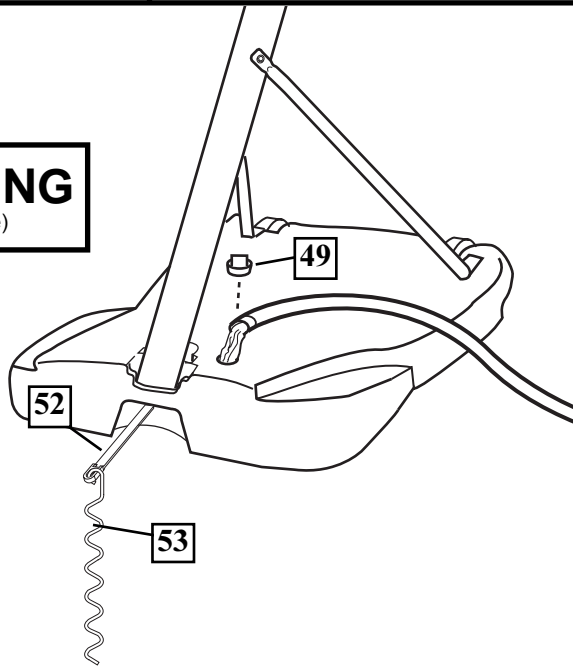

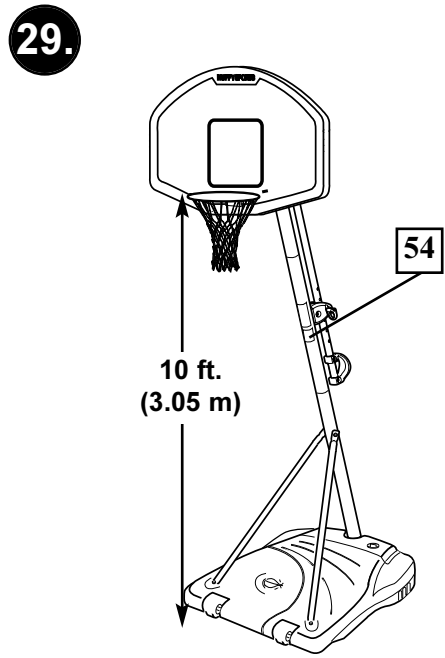
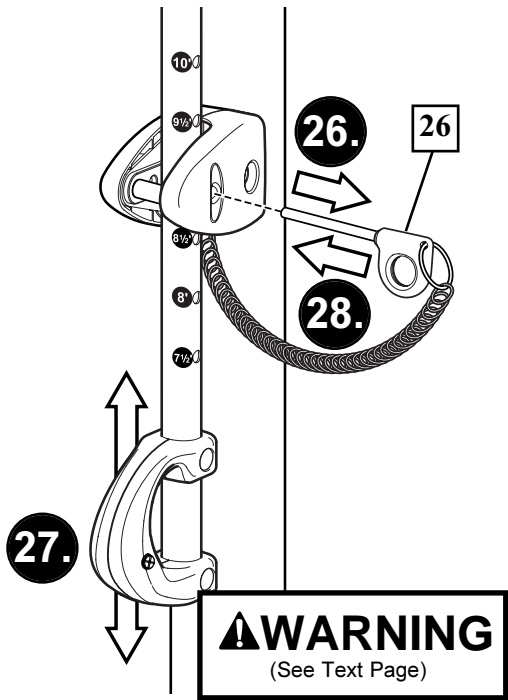

30.

Install net clips.

! WARNING: Use of this product without proper installation of net clips, or when all net clips are not present could result in bodily harm. Be sure to follow directions carefully.

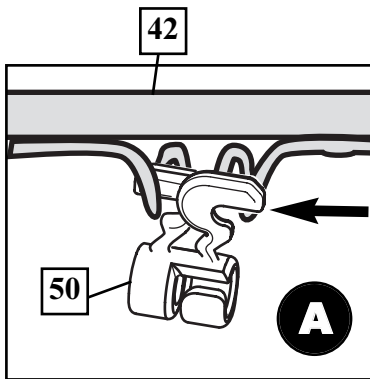
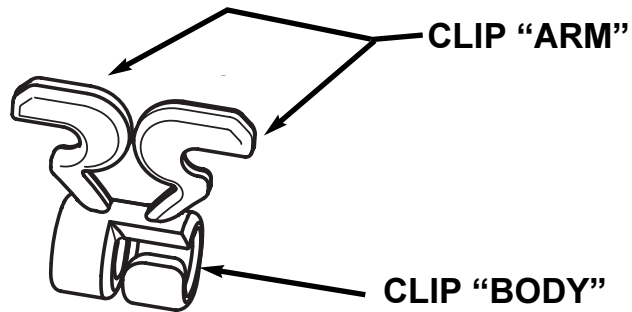

Insert one "arm" of clip into ram as shown. Twist "body" of clip slightly so that second "arm" slides over the top of the first "arm" as shown. Push in direction indicated by arrows.

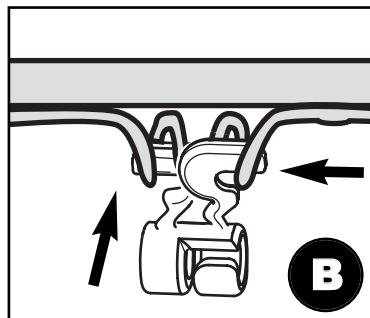

Push second "arm" back and into ram as shown.

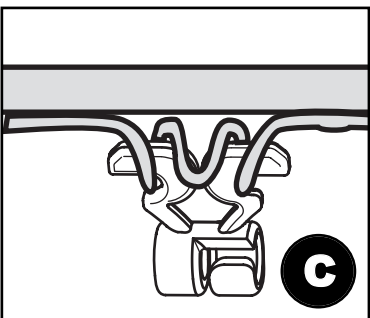

Twist "body" of clip slightly again to spread "arms" of clip. Clip "arms" must be flat and touching edge to edge as shown, not overlapping.

NET INSTALLATION

31.

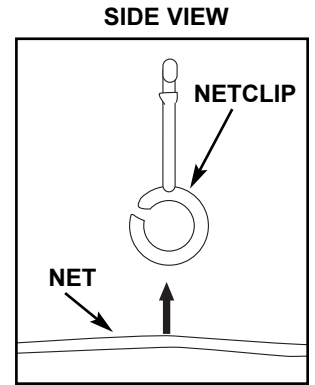
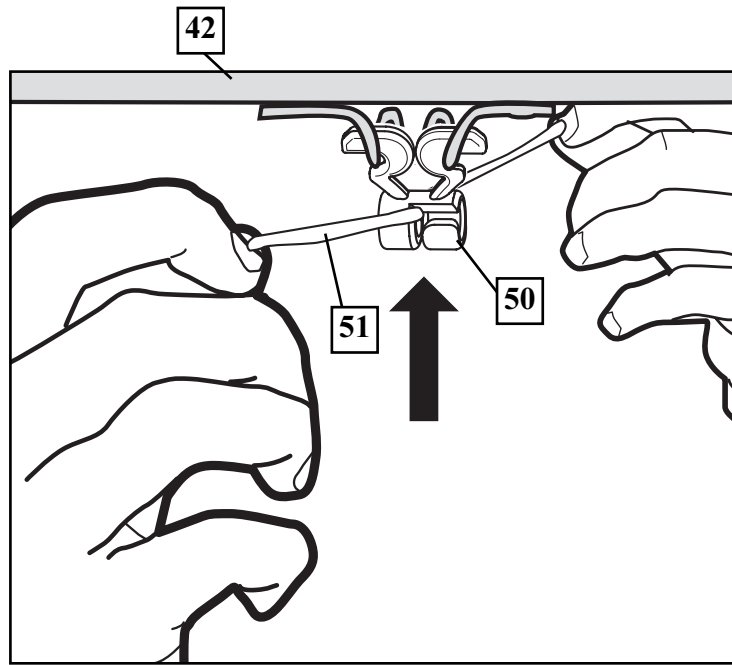

Insert net into bottom of clip as shown.

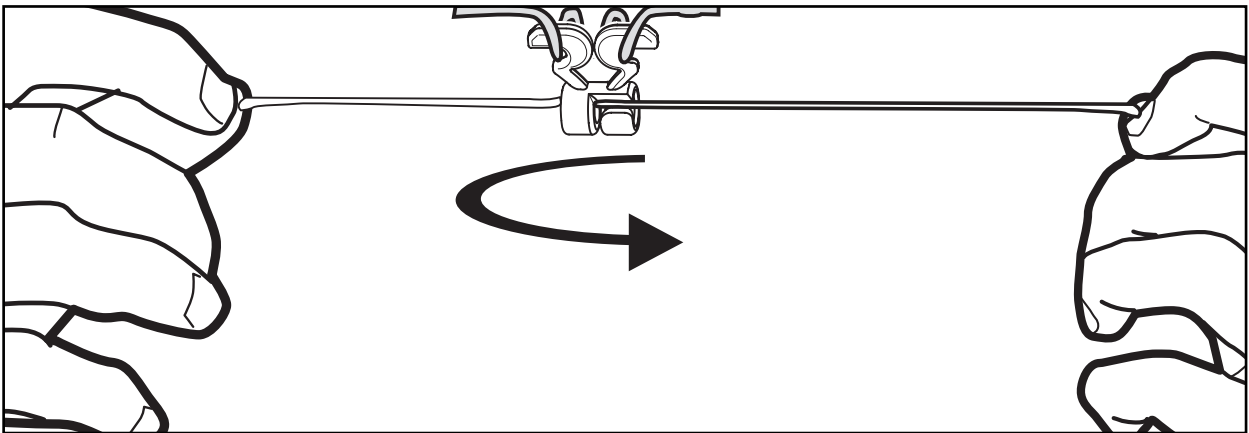

Twist net until it snaps into position.
Net must be centered through clip.

