

- ~ EXPLANATION ~
- 1 Power On/Off
To switch on or off power (Green LED indicates that the power is On)
 - 2 Rotary Volume Control
To adjust the volume higher or lower
 - 3 Line In
To connect the Line In cable from the soundcard/sound Source
 - 4 Power In
To connect the AC/AC adapter
 - 5 Satellite Out
To connect the satellite speakers
- The design of the satellites offers wall mounting as an option.*

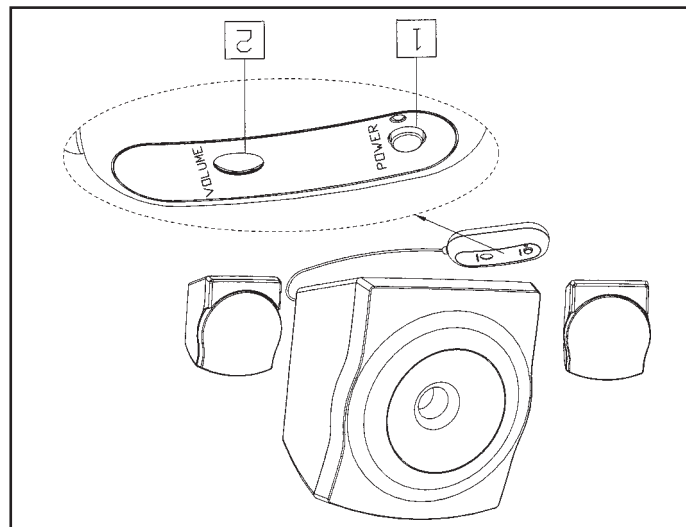
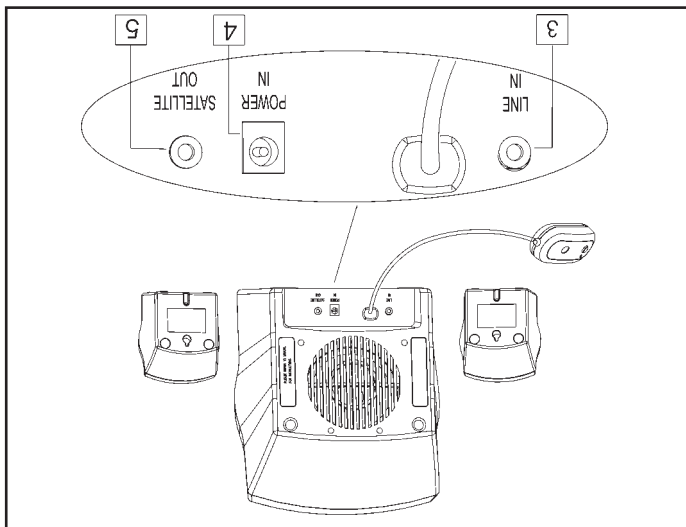

Multimedia Speaker System A 2.300 Compact Power

For US/Canada only

IMPORTANT SAFETY INSTRUCTIONS - Read before operating equipment

This product was designed and manufactured to meet strict quality and safety standards. There are, however, some installation and operation precautions which you should be particularly aware of.

1. Read these instructions - All the safety and operating instructions should be read before the appliance is operated.
2. Keep these instructions - The safety and operating instructions should be retained for future reference.
3. Heed all warnings - All warnings on the appliance and in the operating instructions should be adhered to.
4. Follow all instructions - All operating and use instructions should be followed.
5. Do not use this apparatus near water - for example, near a bathtub, washbowl, kitchen sink, laundry tub, in a wet basement or near a swimming pool, etc.
6. Clean only with a damp cloth. The appliance should be cleaned only as recommended by the manufacturer.
7. Install in accordance with the manufacturer's Instructions. Do not block any of the ventilation openings. For example, the appliance should not be situated on a bed, sofa, rug, or similar surface or placed in a built-in installation, such as a bookcase or cabinet that may impede the flow of air through the ventilation openings.
8. Do not install near any heat sources such as radiators, heat registers, stoves, or other apparatus (including amplifiers) that produce heat.

9. Do not defeat the safety purpose of the polarized or grounding-type plug. A polarized plug has two blades with one wider than the other. A grounding type plug has two blades and a third grounding prong. The wide blade or the third prong are provided for your safety. When the provided plug does not fit into your outlet, consult an electrician for replacement of the obsolete outlet.
10. Protect the power cord from being walked on or pinched particularly at plugs, convenience receptacles, and the point where they exit from the apparatus.
11. Only use attachments/accessories specified by the manufacturer.
12. Use only with a cart, stand, tripod, bracket, or table specified by the manufacturer, or sold with the apparatus. When a cart is used, use caution when moving the cart/appliances combination to avoid injury from tip-over.
13. Unplug this apparatus during lightning storms or when unused for long periods of time.
14. Refer all servicing to qualified service personnel. Servicing is required when the apparatus has been damaged in any way, such as power-supply cord or plug is damaged, liquid has been spilled or objects have fallen into the apparatus, the apparatus has been exposed to rain or moisture, does not operate normally, or has been dropped.



AC Polarized Plug

EL 4562-E004: 99/3



The **A 2.300 Compact Power** consists of 2 satellites, a subwoofer and a remote control and is especially designed as a MultiMedia entertainment speaker system. The aerodynamic front firing subwoofer design will add depth to music and powerful bass to games and sound effects. The two miniature satellite speakers will ease your ears with clean and crisp sound. The easy-to-use remote control will give you the freedom to place your speakers anywhere you want, while still having all the control from your desktop.

<http://www.pcstuff.philips.com>



Installation

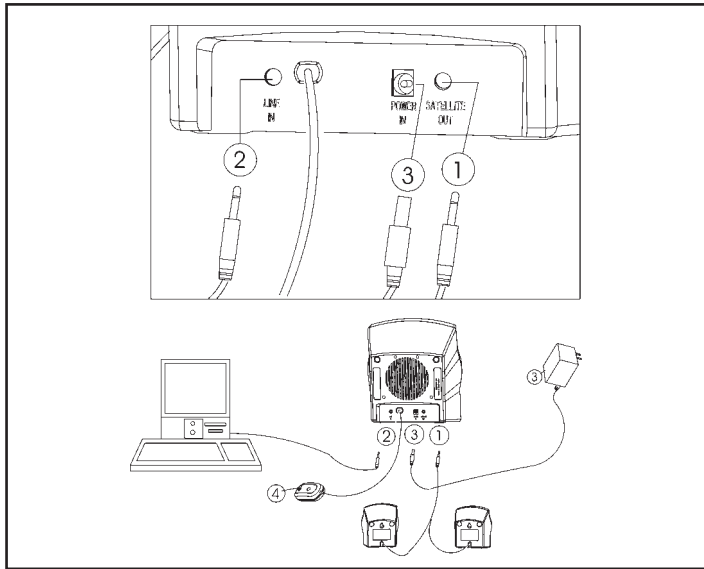

English:

1. Connect the left and right speaker
2. Connect soundcard
3. Connect the power supply
4. Switch on the system using the power button on the remote control
5. Tune the system using sound card/ sound source and the controls on the remote control

Note: Do not insert the power plug into the AC outlet until all connections are made!

Español:

1. Conecte los altavoces derecho e izquierdo
2. Conecte la tarjeta de sonido
3. Conecte el suministro de alimentación
4. Encienda el sistema desde el mando a distancia
5. Aline el sistema ajustando la tarjeta o fuente de sonido y los controles del mando a distancia

Observación: No inserte el conector de alimentación en la toma de corriente mientras no haya completado todas las conexiones

Français:

1. Connectez les haut-parleurs gauche et droit
2. Connectez la carte son
3. Connectez l'alimentation
4. Mettez l'appareil sous tension au moyen du bouton d'alimentation sur la télécommande
5. Procédez à l'accord en vous servant de la carte son/source audio et des commandes sur la télécommande

Remarque: N'introduisez pas la fiche dans la prise CA tant que tous les branchements ne sont pas effectués !

Deutsch:

1. Den linken und rechten Lautsprecher anschließen.
2. Die Soundkarte anschließen
3. Das Netzteil anschließen.
4. Das System mit Hilfe der Taste Power auf der Fernbedienung einschalten.
5. Das System mit Hilfe der Soundkarte/Klangquelle und der Bedienelemente auf der Fernbedienung einstellen.

Hinweis: Den Netzstecker nicht an eine Steckdose anschließen, bevor alle Verbindungen hergestellt worden sind.

Italiano:

1. Collegare la cassa acustica destra e quella sinistra
2. Collegare la scheda audio
3. Collegare all'alimentazione
4. Accendere il sistema con il pulsante di alimentazione sul telecomando
5. Sintonizzare il sistema utilizzando la scheda audio/ sorgente audio e i comandi sul telecomando

Nota: Non inserire la spina di alimentazione nella presa di corrente fino a che i collegamenti non sono stati tutti ultimati!

Polski:

1. Podłączyć prawy i lewy głośnik
2. Podłączyć kartę dźwiękową
3. Podłączyć zasilanie
4. Włączyć system przy pomocy włącznika zasilania na pilocie zdalnego sterowania
5. Dostroić system używając karty dźwiękowej / źródła dźwięku i przycisków sterowania na pilocie

Uwaga: Nie wkładaj przewodu zasilającego do gniazda sieciowego dopóki nie wykonasz wszystkich (innych) połączeń!

Norsk:

1. Kople til den venstre og den høyre høytaleren
2. Kople til lydkortet
3. Kople til strømforsyningen
4. Slå på systemet med av/på-knappen på fjernkontrollen
5. Finjuster systemet ved hjelp av lydkortet/lydkilden og tastene på fjernkontrollen

Merk: Ikke sett støpselet i en stikkontakt før alle tilkoplingene er gjort!

Nederlands:

1. Sluit de linker en rechter luidspreker aan
2. Sluit de geluidskaart aan
3. Sluit het voedingsapparaat aan
4. Schakel het systeem in met de aan/uit-toets op de afstandsbediening
5. Stel het systeem af met behulp van de geluidskaart / geluidsbron en de toetsen op de afstandsbediening

Opmerking: Steek de netstekker pas in het stopcontact als alle aansluitingen gedaan zijn!

中文:

1. 連接左右兩邊揚聲器
2. 連接聲卡
3. 連接電源
4. 使用遙控器電源按鈕打開揚聲器
5. 使用電腦聲卡 / 聲源按鈕或遙控器上的控制調較所需的音響效果。

注意: 除非所有接線都連接妥當，否則勿把 AC 電源線連接上。

Dansk:

1. Tilslut venstre og højre højtaler.
2. Tilslut lydkortet.
3. Tilslut strømforsyningen.
4. Tænd systemet ved hjælp af tænd-/slukknappen på fjernbetjeningen.
5. Afstem systemet ved hjælp af lydkortet / lydkilden og betjeningselementerne på fjernbetjeningen.

Bemærk: Sæt netstikket ikke til i vekselstrømsudgangen, før alle tilslutninger er i orden!

Svenska:

1. Anslut den vänstra och den högra högtalaren
2. Anslut ljudkortet
3. Anslut nätspänningen
4. Slå på systemet med hjälp av till/frånknappen på fjärrkontrollen
5. Ställ in systemet med hjälp av ljudkortet / ljudkällan och knapparna på fjärrkontrollen.

Obs: Anslut inte nätkontakten till nätuttaget förrän alla anslutningar har gjorts!

Türkçe:

1. Sağ ve sol hoparlörleri bağlayınız.
2. Ses kartını takınız
3. Güç kaynağını bağlayınız
4. Uzaktan kumanda üzerindeki açma-kapama düğmesini kullanarak sistemi açınız
5. Ses kartı / ses kaynağı ve uzaktan kumada üzerindeki kontrolleri kullanarak sistemin sesini açınız

Not: Bütün bağlantıları yapmadan elektrik fişini AC çıkışına takmayınız!

Suomi:

1. Kytke vasen ja oikea kaiutin.
2. Kytke äänikortti.
3. Yhdistä pistotulppa pistorasiaan.
4. Kytke järjestelmä toimintaan kauko-ohjaimen virtapainikkeella.
5. Viritä järjestelmä äänikortin/äänilähteen sekä kauko-ohjaimen säätimien avulla.

Huom: Älä yhdistä pistotulppaa pistorasiaan, ennen kuin kaikki kytkennät ovat valmiit!

Русский:

1. Подсоедините левую и правую акустические колонки.
2. Подсоедините звуковую карту.
3. Подключите источник питания.
4. Включите систему, нажав кнопку включения питания на пульте дистанционного управления
5. Настройте систему, используя звуковую карту, источник звука и управляющие кнопки пульта дистанционного управления.

Примечание: Не подсоединяйте вилку сетевого шнура к розетке сетепеременного тока, пока не будут выполнены все необходимые соединения!

Important notes for users in the U.K.

Mains plug
This apparatus is fitted with an approved 13 Amp plug.
To change a fuse in this type of plug proceed as follows:

- 1 Remove fuse cover and fuse.
- 2 Fix new fuse which should be a BS1362 5 Amp, A.S.T.A. or BSI approved type.
- 3 Refit the fuse cover.

If the fitted plug is not suitable for your socket outlets, it should be cut off and an appropriate plug fitted in its place. If the mains plug contains a fuse, this should have a value of 5 Amp. If a plug without a fuse is used, the fuse at the distribution board should not be greater than 5 Amp.

Note: The severed plug must be disposed of to avoid a possible shock hazard should it be inserted into a 13 Amp socket elsewhere.

How to connect a plug

The wires in the mains lead are coloured with the following code: blue = neutral (N), brown = live (L). As these colours may not correspond with the colour markings identifying the terminals in your plug, proceed as follows:

- Connect the blue wire to the terminal marked N or coloured black.
- Connect the brown wire to the terminal marked L or coloured red.
- Do not connect either wire to the earth terminal in the plug, marked E (or \perp) or coloured green (or green and yellow).

Before replacing the plug cover, make certain that the cord grip is clamped over the sheath of the lead - not simply over the two wires.

Copyright in the U.K.
Recording and playback of material may require consent. See Copyright Act 1956 and The Performer's Protection Acts 1958 to 1972.

Norge

Typeskilt finnes på apparatens underside.

Observer: Nettbryteren er sekundert innkople. Den innebygde nettdelen er derfor ikke frakople nettet så lenge apparatet er tilsluttet nettkontakten.

For å redusere faren for brann eller elektrisk støt, skal apparatet ikke utsettes for regn eller fuktighet.

Deutschland

Hiermit wird bescheinigt, daß dieses Gerät in Übereinstimmung mit den Bestimmungen der Amtsblattverfügung 1046/1984 funktentstört ist.

Der Deutschen Bundespost wurde das Inverkehrbringen dieses Gerätes angezeigt und die Berechtigung zur Überprüfung der Serie auf Einhaltung der Bestimmungen eingeräumt.