



PYLE[®] DRYWER

**BRIDGEABLE MOSFET
POWER AMPLIFIERS**

**PLAD212/PLAD213/PLAD214
PLAD215/PLAD412/PLAD413
PLAD618**

OWNER'S MANUAL



TABLE OF CONTENTS

TABLE OF CONTENTS

INTRODUCTION & FEATURES	2
SPECIFICATION	3
FEATURES & CONTROLS	4-9
INSTALLATION & PRECAUTIONS	10
SYSTEM WIRING	11-14
TROUBLE SHOOTING	15
WIRING	16

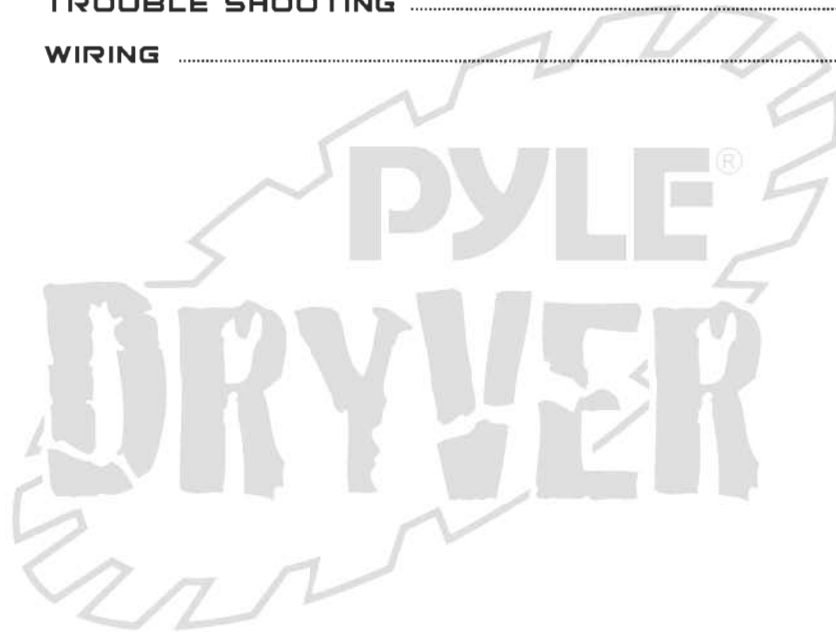

INTRODUCTION & FEATURES

INTRODUCTION

Congratulations on your purchase of a PYLE amplifier. You have purchased a quality product designed and engineered to give you many years of uncompromised musical service. PYLE amplifiers are designed with the latest technology available, incorporating a DC to DC Switching Power Supply, which provides headroom for even the most demanding peaks and dynamic ranges found on modern CD's and recordings.

FEATURES

- **Electronic Crossover Network**
- **Bass Boost Circuit**
- **Bridgeable at 4 Ohms**
- **2 Ohm Stereo Stable**
- **Tri-Mode Capable**
- **Gold Plated RCA Inputs**
- **Line Outs for Left and Right Channel(PLAD212/213/214/215/216)**
- **Line Outs for 1/2 Channel(PLAD412/413)**
- **Low Pass Filter Controls**
- **High Pass Filter Controls**
- **Remote Bass Level Control(optional)**
- **Power and Protection LED Indicators**
- **RED Lighting Illumination**
- **Side Leg Mounting**
- **Soft Turn-on/Turn-off**

SPECIFICATION

SPECIFICATION

	PLAD212	PLAD213	PLAD214	PLAD215
RMS at 4 Ohms	2 X 100W	2 X 150W	2 X 250W	2 X 500W
MAX at 4 Ohms	2 X 400W	2 X 500W	2 X 800W	2 X 1000W
MAX at 4 Ohms BRIDGED	400W	600W	900W	1300W
RMS at 2 Ohms	2 X 175W	2 X 250W	2 X 400W	2 X 700W
T.H.D	<0.04%	<0.04%	<0.04%	<0.04%
S/N RATIO	>90dB	>90dB	>90dB	>90dB
Input Sensitivity	100mV ~ 4V	100mV ~ 4V	100mV ~ 4V	100mV ~ 4V
Channel Separation	>65dB	>65dB	>65dB	>65dB
Frequency Response	10Hz ~ 30KHz	10Hz ~ 30KHz	10Hz ~ 30KHz	10Hz ~ 30KHz
Dimensions (W x H x L)	8.6" x 2.27" x 7"	8.6" x 2.27" x 8.7"	8.6" x 2.27" x 9.84"	8.6" x 2.27" x 17.7"

	PLAD412	PLAD413	PLAD618
RMS at 4 Ohms	4 X 100W	4 X 200W	4 X 100W + 2 X 250W
MAX at 4 Ohms	4 X 250W	4 X 500W	4 X 250W + 2 X 500W
MAX at 4 Ohms BRIDGED	2 X 400W	2 X 800W	2 X 400W + 1 X 900W
RMS at 2 Ohms	4 X 150W	4 X 350W	4 X 175W + 1 X 400W
T.H.D	<0.04%	<0.04%	<0.04%
S/N RATIO	>90dB	>90dB	>90dB
Input Sensitivity	100mV ~ 4V	100mV ~ 4V	100mV ~ 4V
Channel Separation	>65dB	>65dB	>65dB
Frequency Response	10Hz ~ 30KHz	10Hz ~ 30KHz	10Hz ~ 30KHz
Dimensions (W x H x L)	8.6" x 2.27" x 11.4"	8.6" x 2.27" x 12.6"	8.6" x 2.27" x 19.7"

FEATURES & CONTROLS

PLAD212/213/214/215

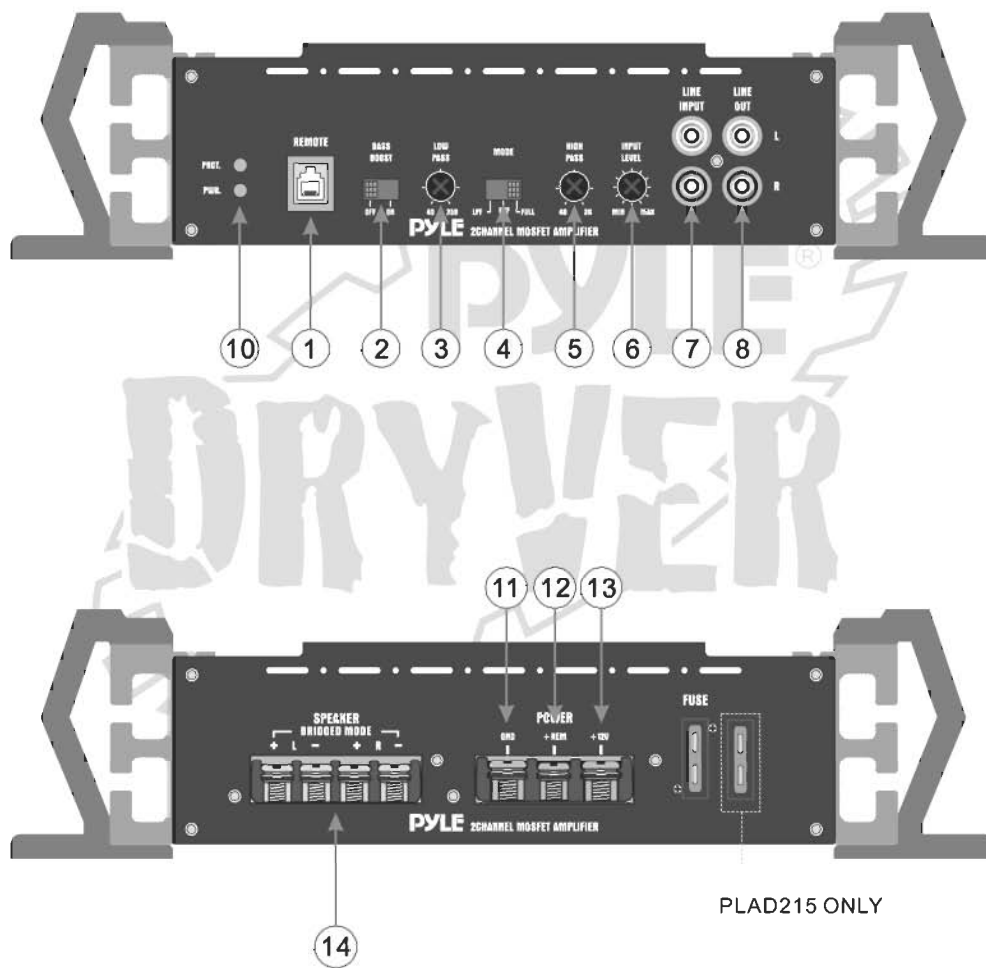

FEATURES & CONTROLS

PLAD412 / 413

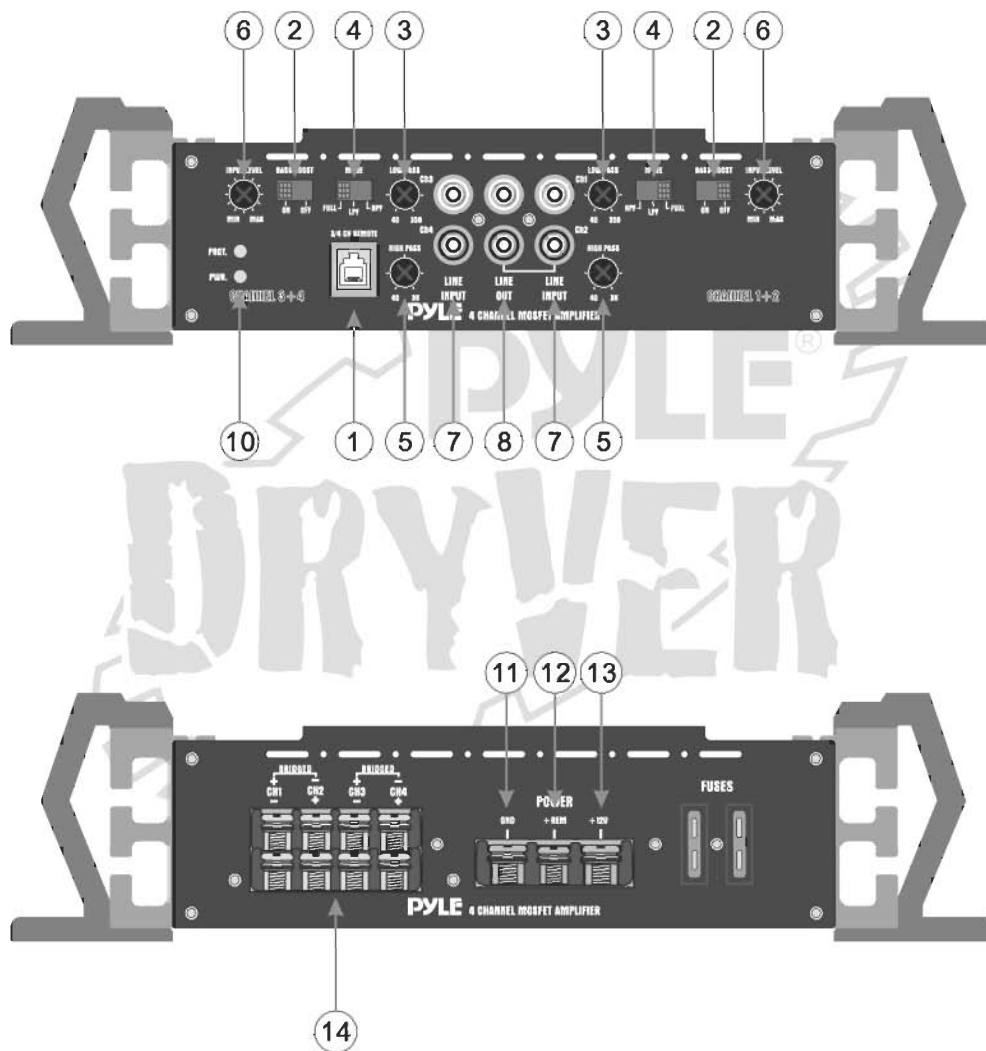

FEATURES & CONTROLS

PLAD618

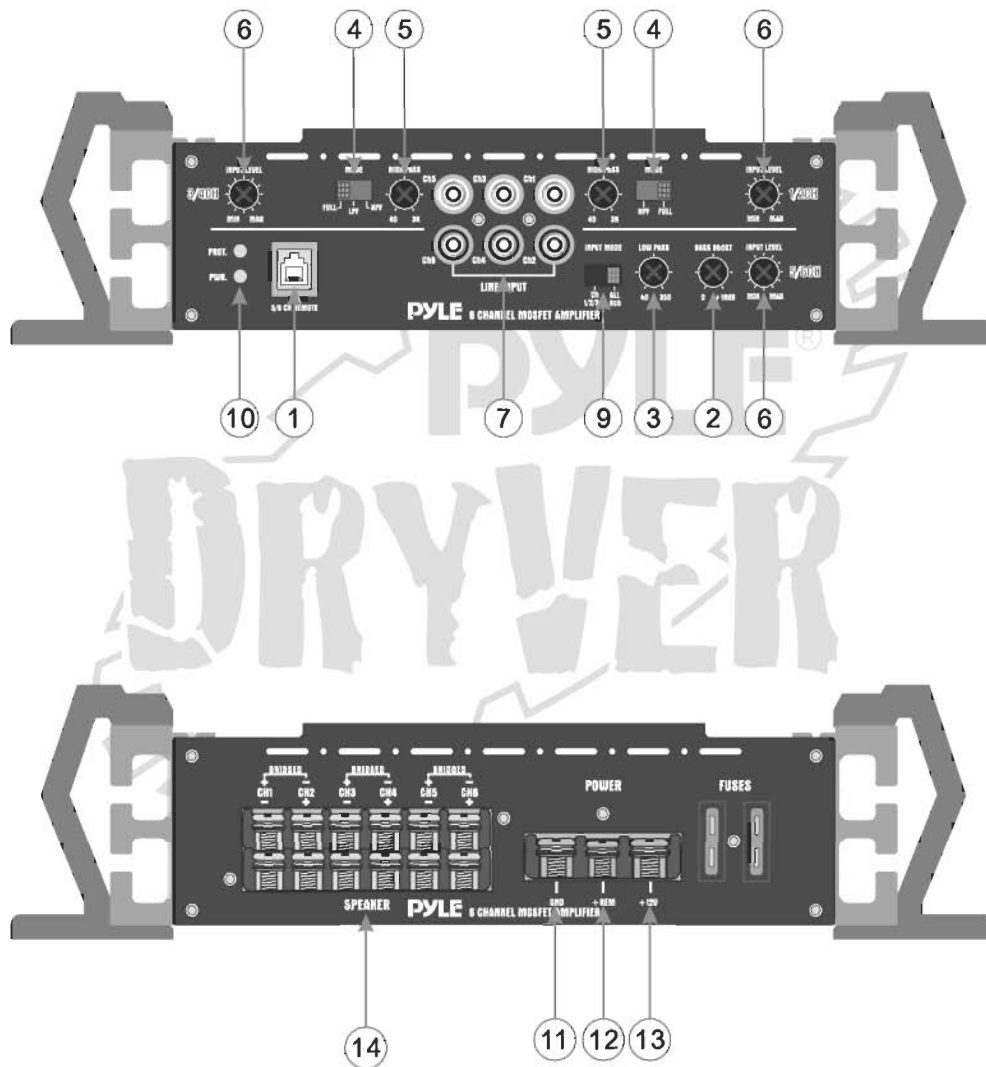

FEATURES & CONTROLS

1. Remote Control Input (Fig-1)

2. Bass Boost Control

- Bass Boost control - ON/OFF(PLAD212/213/214/215/412/413)
By using the Bass Boost function, bass notes at 35Hz-80Hz are emphasized as much as 10dB
- Variable Bass Boost(PLAD618)
By using the Bass Boost function, bass notes at 45Hz are emphasized as much as 18dB.

3. Low Pass Filter

When Crossover Mode Selector is in Low Pass Mode, this control limits the frequencies which will be distributed to the speakers to those below the value to which this is set within the range 40~350Hz.

4. Crossover Mode Switch

Adjust the crossover for your chosen installation method.

- LPF: Low pass filter- only bass tones (40Hz~350Hz) go to speakers.
Use with woofer or sub-woofer.
- FULL: No filter- all tones go to speakers. Use with full-range speakers, or with external crossovers.
- HPF: High pass filter-blocks very low tones(40Hz~3kHz) from the speakers.

5. High Pass Filter

When Crossover Mode Selector is in High Pass Mode, this control limits the frequencies which will be distributed to the speakers to those above the value to which this is set within the range 40Hz~3kHz.

6. Input Level Controls

Enables the matching of input levels to the output levels from the head unit(or other signal source).

7. Line Input RCA Jacks

These inputs are for signal cables from the source. Always use high quality shielded RCA cables.

8. Line Out RCA Jacks

The LINE OUT allows you to build multiple amplifier systems without having to use splitter cords to distribute the signal. Now it is simple a matter of bringing one set of RCAs into the first amplifier, then using the line out RCA jacks as the feed to the next amplifier.

FEATURES & CONTROLS

9. Input Mode

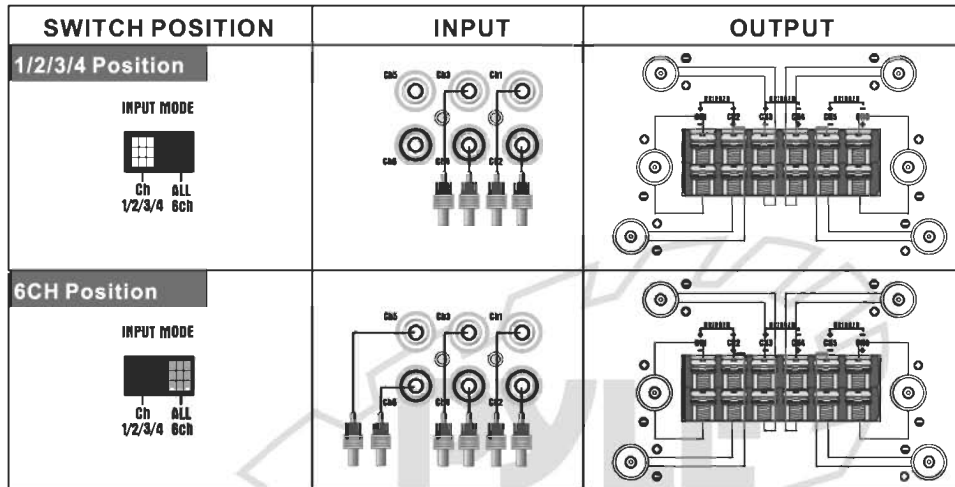

10. LED Indicator

- **POWER** : This GREEN LED will illuminate when the amplifier is turned "ON".
If it fails to illuminate, check the power connections to the Amplifier and fuses.
- **PROTECTION** : The amplifier protection circuitry will disable the amplifier if input overload, short circuit or extremely high temperature conditions are detected. When the protection mode is in operation, the LED indicator on the side panel will be illuminated, indicating the amplifier has gone into a self preservation mode.

If you observe that the Protection LED is lit, please check the system carefully to determine what has caused the protection circuit to engage. The amplifier can be reset by turning the remote power off and then on again. If the amplifier shut down due to a thermal overload condition, please allow it to cool down before restarting. If the amplifier shut down because of an input overload or short circuit, be sure to repair these conditions before attempting to power up the amplifier again.

FEATURES & CONTROLS

11. B- TERMINAL (CHASSIS GROUND)

To avoid unwanted ignition noise caused by ground loops, it is essential that the Amplifier be grounded to a clean, bare, metal surface of the vehicles chassis.

12. REMOTE POWER ON

To remote wire car stereo. This amplifier is turned "ON" remotely when vehicle's stereo is turned "ON".

Note: IF YOUR RADIO DOES NOT HAVE +12 VOLT OUTPUT LEAD WHEN TURNED ON, THE "REMOTE" TERMINAL ON THE AMPLIFIER CAN BE CONNECTED TO VEHICLES ACCESSORY CIRCUIT WHICH PROVIDES +12V WHEN THE CAR IS ON.

13. B+ TERMINAL (BATTERY POSITIVE)

Due to the power requirements of the Amplifier, this connection should be made directly to the positive(+) terminal of battery. For safety measure, install an in-line fuse Holder (not included) as close to the battery positive(+) terminal as possible with an ampere rating not to exceed total value of fuses in Amp.

14. SPEAKER TERMINAL

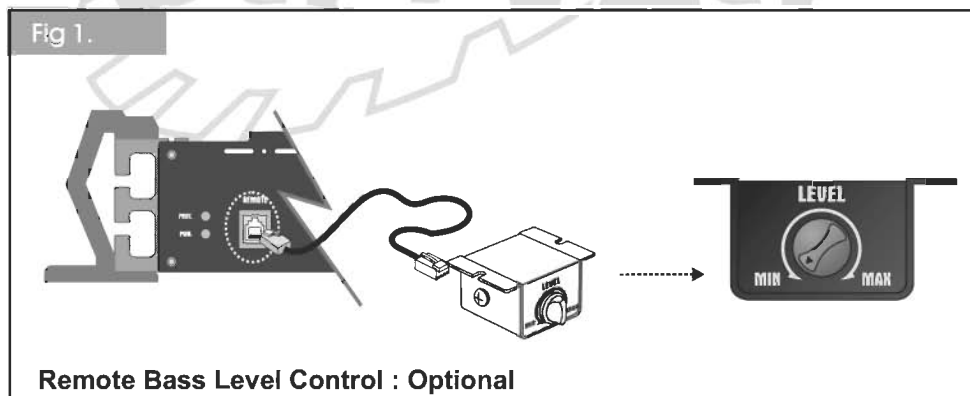

Remote Bass Boost Control : This control adjusts the Bass Boost gain for the amplifier's speaker output (0 - +12dB)

INSTALLATION & PRECAUTIONS

INSTALLATION

1. Find a suitable location in the vehicle to mount the amplifier.
2. Make sure there is sufficient air flow around the intended mounting location.
3. Bolt the amplifier to the mounting surface.
4. Connect the power ground terminal to the nearest point on the chassis of the car. Keep this ground wire less than one meter (39") in length. Use 8 gauge wire.
5. Connect the remote terminal to the remote output of the head unit using 14 gauge wire.
6. Connect an empty fuse holder within 300 mm (12") of the battery and run 8 gauge or larger high quality cable from this fuse to the amplifier location.
7. Make sure there is no fuse in this fuse holder. Then make the connection to the "BATT" connection on the amplifier.
8. If multiple amplifiers are being used, use cables (each with its own fuse at the battery) or a # 0 or #2 cable from the fuse holder at the battery to a distribution block at or near the amplifier's location.
9. Connect all line inputs and outputs using high-quality RCA-RCA cables.
10. Insert fuse(s) at the battery fuse holder(s).
11. Recheck all connections before powering up.
12. Set all level controls to their least sensitive positions and set all crossover controls, switches, etc. To the desired frequency or position.
13. Once the system is powered up, set the volume control on the head unit to about the 2 O'clock position, and then set all the amplifiers' level controls for maximum output level.
14. Further fine tuning of the various controls may be m'necessary to obtain the desired results.

PRECAUTIONS

1. Before you drill or cut any holes, investigate your car's layout very carefully. Take care when u work near the gas tank, fuel lines, hydraulic lines and electrical wiring..
2. Do not operate the amplifier when it is unmounted. Attach all audio system components securely within the automobile to prevent damage, especially in an accident
3. Do not mount this amplifier so that the wire connections are unprotected or in a pinched condition, or likely to be damaged by nearby objects. Be sure to select a location inside your vehicle which has adequate ventilation..
4. Before making or breaking power connections in your system, disconnect the vehicle battery. Confirm that your head unit or other equipment is turned off while connecting the input jacks and speaker terminals.
5. If you need to replace the power fuse, only replace it with a fuse identical to that supplied with the system. Using a fuse fo a different type or rating may result in damage to your system which isn't covered by the manufacturer's warranty.

SYSTEM WIRING

SYSTEM WIRING

PLAD212/213/214/215

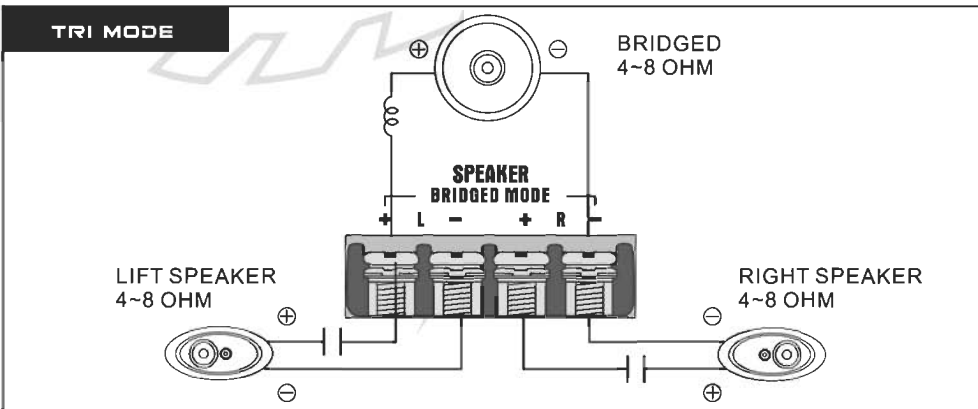
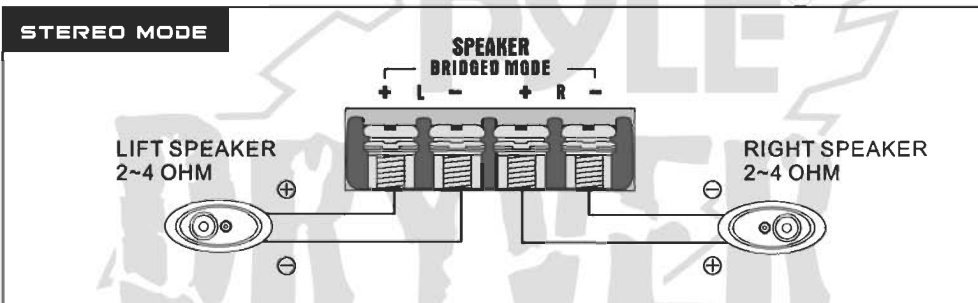
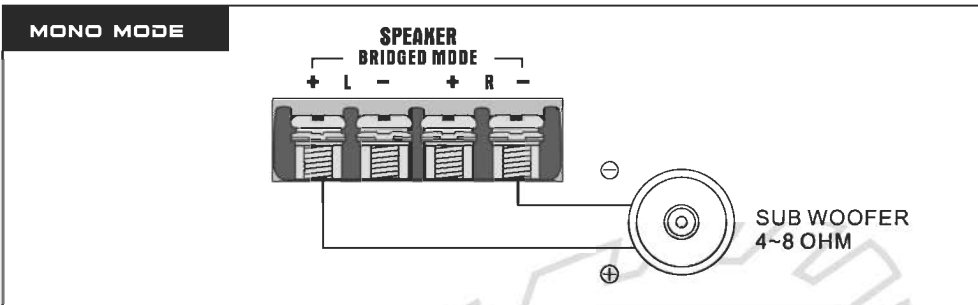

 INDUCTOR LOW PASS FILTER

 CAPACITOR HIGH PASS FILTER

SYSTEM WIRING

SYSTEM WIRING

PLAD412/413

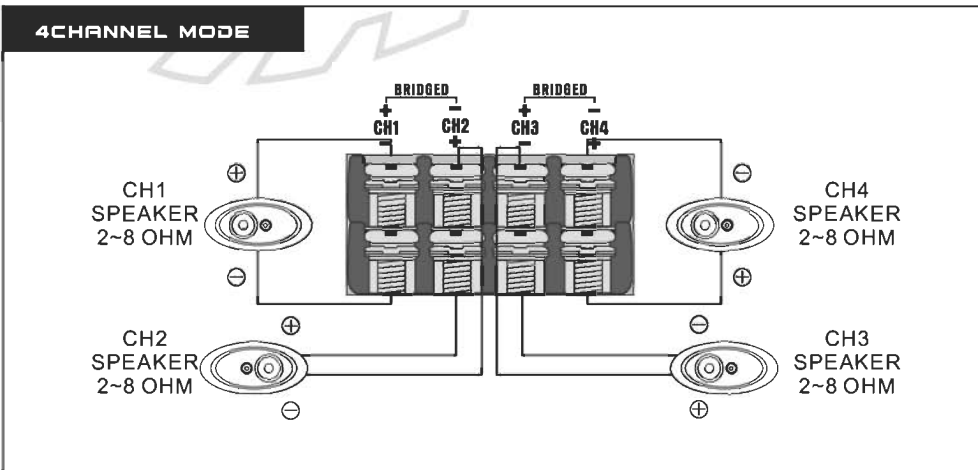
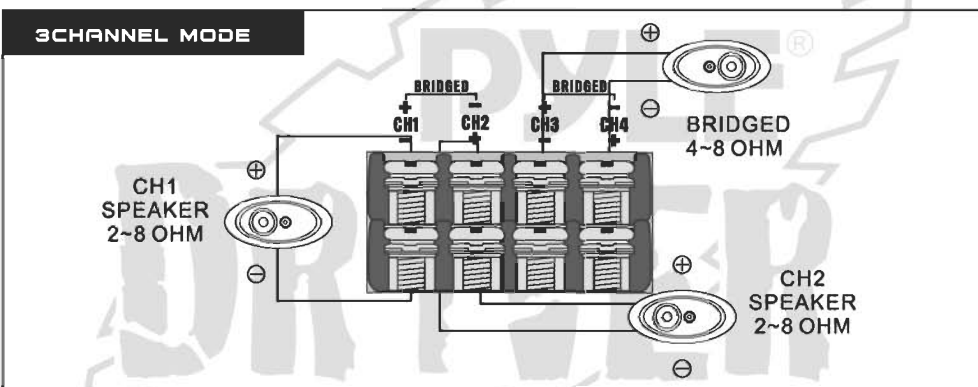
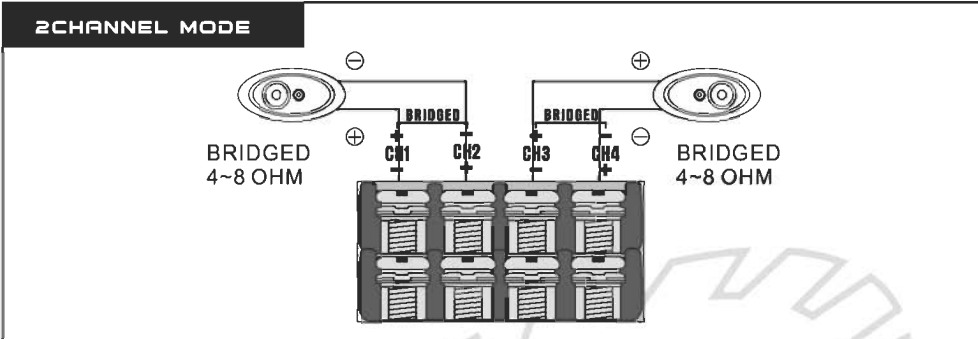

SYSTEM WIRING

SYSTEM WIRING

PLAD412/413

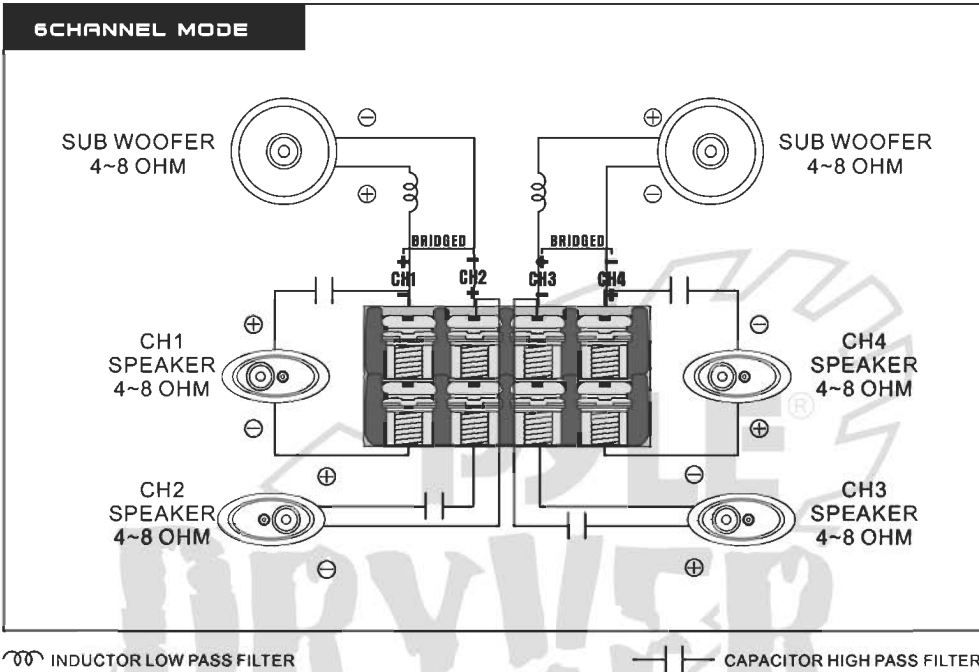

SYSTEM WIRING

SYSTEM WIRING

PLAD618

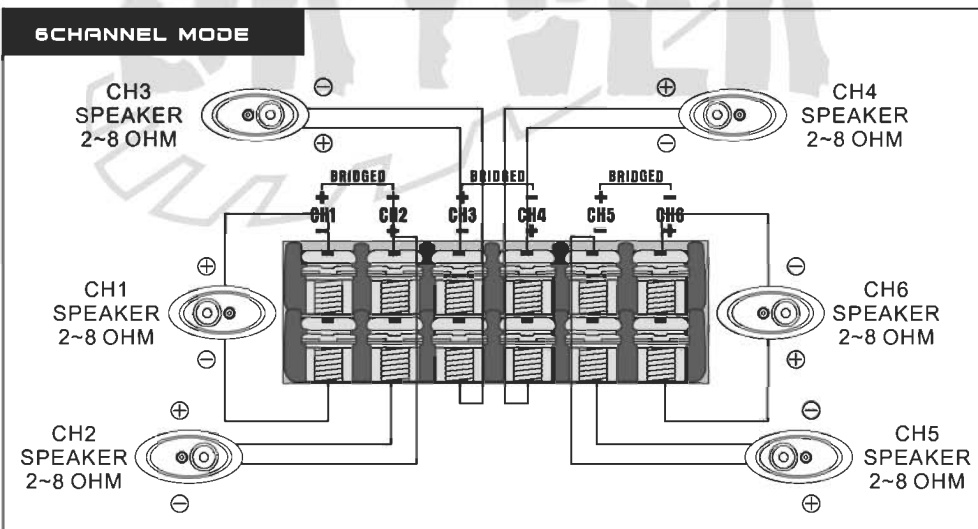
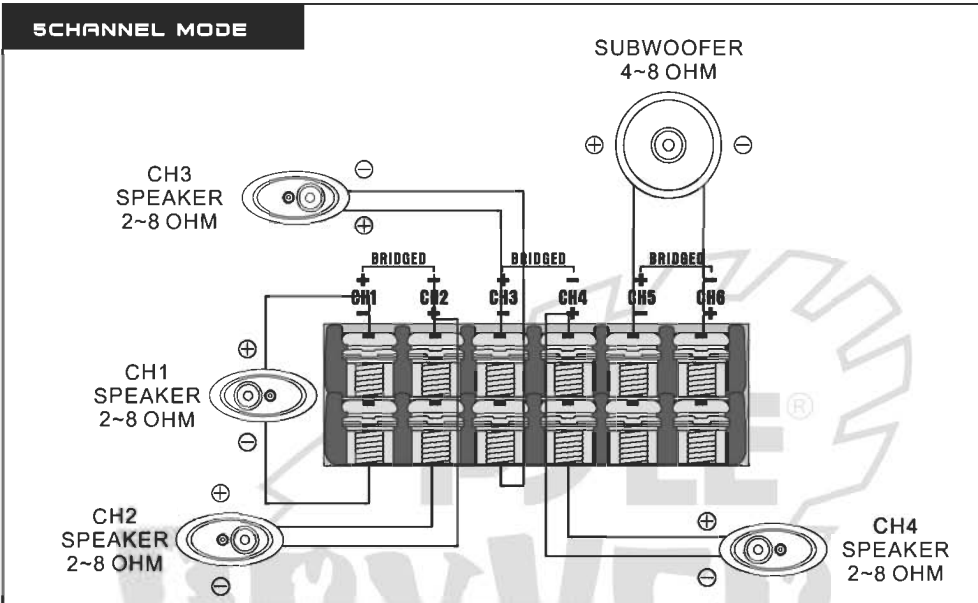

TROUBLESHOOTING

TROUBLESHOOTING

Amplifier will not power up.

- Check for good ground connection.
- Check that remote DC terminal has at least 3V DC.
- Check that there is battery power on the + terminal.
- Check all fuses.
- Check that Protection LED is not lit. If it is lit, shut off amplifier briefly and then repower it.

High hiss or engine noise (alternator whine) in speakers.

- Disconnect all RCA inputs to the amplifier(s)-if hiss/noise disappears, then plug in the component driving the amplifier and unplug it's inputs. If hiss/noise disappears, go on until the faulty/noisy component is found.
- It is best to set the amplifier's input level as low as possible. The best subjective S/N ratio is obtainable this way. Try to drive as high a signal level from the head unit as possible.

Protection LED comes on when the amplifier is powered up.

- Check for shorts on speaker leads.
- Check that the volume control on the head unit is turned down low.
- Remove speaker leads, and reset the amplifier. If the Protection LED still comes on, then the amplifier is faulty.

Amplifier(s) gets very hot.

- Check that the minimum speaker impedance for that model is correct.
- Check for speaker shorts.
- Check that there is good airflow around the amplifier. In some applications, an external cooling fan may be required.

Distorted Sound

- Check that the Level control(s) is set to match the signal level of the head unit.
- Check that all crossover frequencies have been properly set.
- Check for shorts on the speaker leads.

High squeal noise from speakers.

- This is almost always caused by a poorly-grounded RCA patch cord.

WIRING

2 CHANNEL

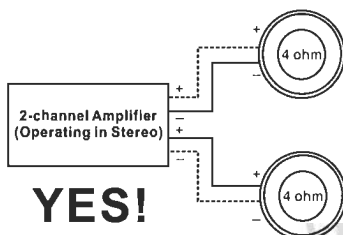

YES!

Two 4-ohm speakers, wired in stereo, will present a 4 ohm load to each channel of the amplifier. Most two-channel amplifiers will work well in this configuration.

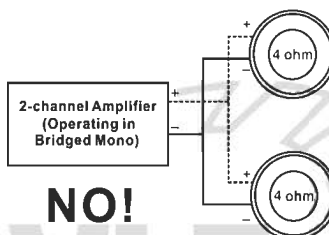

NO!

Two 4-ohm speakers, wired in parallel to a bridged two-channel amplifier, will present a 2-ohm mono load to the amplifier. **MOST TWO-CHANNEL AMPLIFIERS DO NOT SUPPORT 2-OHM MONO OPERATION! AMPLIFIER DAMAGE COULD RESULT!**

4 CHANNEL

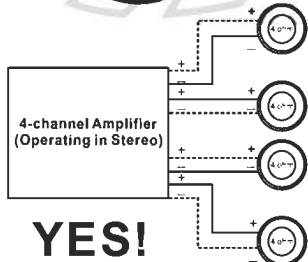

YES!

Four 4-ohm speakers, wired in stereo, will present a 4 ohm load to each channel of the amplifier. Most four-channel amplifiers will work well in this configuration.

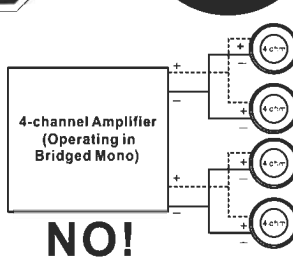

NO!

Four 4-ohm speakers, wired in parallel to a bridged four-channel amplifier, will present a 4-ohm mono load to the amplifier. **MOST FOUR-CHANNEL AMPLIFIERS DO NOT SUPPORT 2-OHM MONO OPERATION! AMPLIFIER DAMAGE COULD RESULT!**

The logo consists of the words "PYLE" and "DRYVER" stacked vertically. "PYLE" is in a bold, sans-serif font with a registered trademark symbol (®) to its upper right. "DRYVER" is in a larger, bold, sans-serif font with a distressed, cracked texture. The text is enclosed within a white, jagged sawtooth border that resembles a circular saw blade. The background is dark with faint, repeating sawtooth patterns.

PYLE[®]
DRYVER

www.pyleaudio.com

Printed in korea.