

PROFILE®

INSTALLATION INSTRUCTIONS / OWNER'S MANUAL

PCD970R

AM/FM HIGH POWER FLIP DOWN DETACHABLE FACE
CD PLAYER

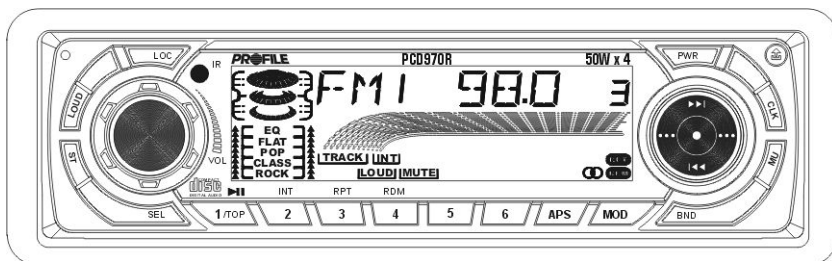

COMPACT
disc
DIGITAL AUDIO

INTRODUCTION

Congratulations on your purchase of a Profile state-of-the-art single disc CD player. Your selection of a Profile car audio product indicates a true appreciation of fine musical reproduction. Whether adding to an existing system or including your Profile CD player in a new system, you are certain to notice immediate performance benefits.

FEATURES

- 50W x 4 Power Output
- Flip Down Detachable Face
- Remote Control
- Dual RCA Line Output(Front & Rear)
- Auxiliary RCA Line Input
- Clock
- 30 Station Memory
- 4 Band Preset Equalizer
- Loud Function
- Power Level Meter
- ISO/DIN Mounting
- Blinking Security L.E.D.
- Full Electronic Function Controls
- Disc Scan, Random & Repeat Play

KEEP YOUR SALES RECEIPT

Take this time to attach your sales receipt to the manual and put in a safe place. In case of any reason this product may need warranty service, your receipt will be necessary to establish purchase date.

IMPORTANT! Before making any connections, disconnect the car's battery until the installation is completed to avoid possible damage to the electrical system.

Serial # _____ Purchase Date _____

SAFETY PRECAUTIONS

Secure the CD player.

When installing your CD player in the vehicle, make sure it is mounted properly in the dash, using an after market installation kit if needed. When using the supplied mounting sleeve, **it is a must that you also use the supplied back brace to support the back of the CD player.**

Use caution when mounting the CD player.

Remember there are many electrical wires, vacuum lines, brake lines and air bag deployment wires. Make sure you know where they are when mounting the CD player to avoid puncturing lines, and shorting wires.

Use high grade wire connectors.

To ensure maximum power transfer and secure safe connections, it is recommended to use high grade barrel or crimp cap connectors.

Do not run any wires underneath the vehicle.

Exposed wires can be cut or damaged. It is best to run all wires through the vehicle under the carpet and/or side panels. This enables to a cleaner installation and less risk of damage.

Run signal wires away from electrical wires

To avoid possibility of induced noise from the car's electrical system (i.e. popping noises or engine noise), run signal wires away from the car's electrical wiring.

Make all ground wires as short as possible and terminated at the same point.

In order to reduce the chance of ground loops (i.e. engine noise), make the grounded wire as short as possible to reduce the wire's resistance. Also, when using multiple components, make sure all units are grounded at the same point.

Avoid sharp edges when running the wires.

To avoid the possibility of power, signal or speaker shorts, be careful not to allow the amplifier wires to come in contact with sharp edges. Use a grommet to protect the wire when running through the fire wall .

CARE AND MAINTENANCE

Cleaning the CD player

When cleaning the vehicle, be sure not to get any water in or on the CD player. Clean only the exterior surface of the unit with a dry, clean soft towel using no chemical solvents.

Operating in extreme temperatures

Sometimes the unit will not operate in extreme, hot or cold temperatures. If this is the case, wait until the temperature in the vehicle is normal, then resume operation.

Protect your CDs.

When not using the disc player, it is recommended that you remove the CD.

Do not leave an ejected disc sitting on the edge of the disc player for long periods of time. The disc will warp under direct sunlight. Always put each disc in its case to protect them during times of non-use.

CD operation.

Never attempt to force anything other than a compact disc in the disc slot. This disc player is a precision instrument that could be damaged by a foreign object.

Disc skip

When driving down a very rough road, the disc may skip. This will not scratch or damage the disc.

Removing and protecting detachable face plate.

The face plate of the unit may be removed as a theft deterrent. After removing the face plate, use the case provided to keep the face plate from getting damaged.

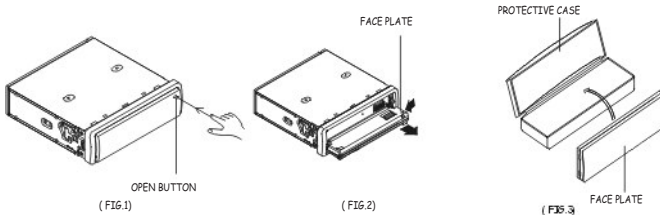

Press the OPEN button to flip down the face plate (Fig 1). Then slightly push the face plate towards the left side before pulling it out from the unit (Fig.2)

Store the face plate in the protective case provided for safe keeping (Fig.3).

DISC CARE AND PLAY:

- Before playing, clean the disc with a clean, lint-free cloth. Wipe the disc in the direction of the arrow.

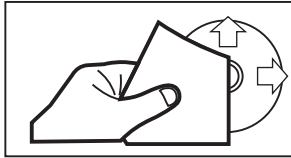

- Do not use solvents such as benzine or thinners. Commercially available cleaners or anti static spray will damage the unit.
- Insert a disc with the labeled surface up.

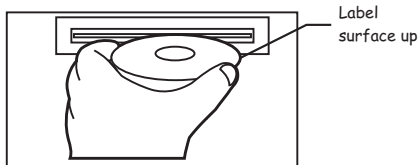

- Do not try to insert another disc when one has already been inserted. Doing so may damage the unit.
- Handle the disc by its edge to keep the disc clean and do not touch the surface.

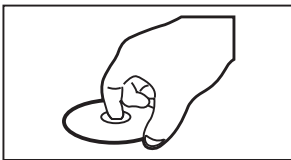

- Do not stick paper or tape on the disc.
- Do not expose the disc to direct sunlight which can cause the disc to warp.
- Always store the disc in its case for protection. Scratched up discs will produce poor sound performance and cause CD player to skip.

ELECTRICAL AND SIGNAL CONNECTIONS

Before making the following connections, take time to look over the vehicle's wiring and determine the location and wires you will be connecting to. If you do not wish to cut or tap into the vehicles existing factory wiring, there are wiring kits available at your car audio retailer that will allow you to plug directly into the factory wiring harness. Make sure to test all wires before connecting to the CD Player.

- Connect Black wire to chassis ground.
- Connect the Yellow memory backup wire to a Constant +12 Volt power source wire.
- Connect the Red ignition wire to a switched +12 Volt power source wire. (The power wire that is energized when the key is in the accessory position).
- The blue wire is connected only if a power antenna or an amplifier is used in the system. This wire supplies +12 Volt output when the CD Player is turned on, which activates most power antenna relays or amplifier turn on circuits.

FOUR SPEAKER SYSTEM

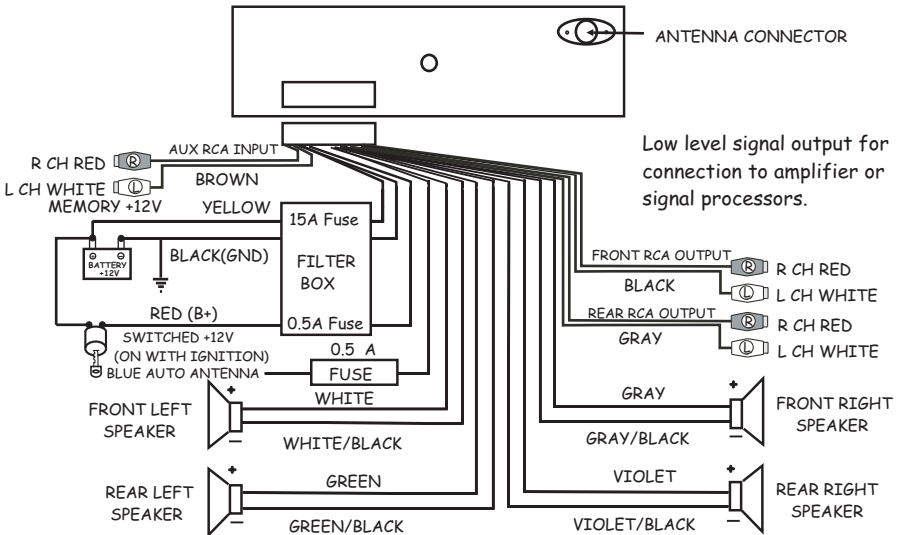

TWO SPEAKER SYSTEM

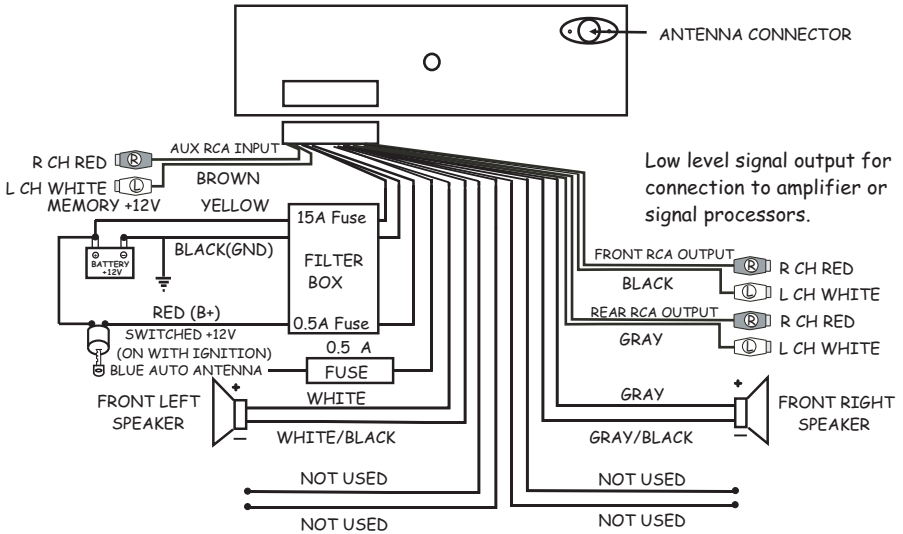

CAUTION! Tape unused wires so they do not short against other wires or chassis ground.

MOUNTING THE CD PLAYER

There are two different ways to mount the CD Player. In most Japanese vehicles you can use the factory mounting brackets, taking advantage of the ISO/DIN opening. If your vehicle does not have ISO/DIN opening, you can mount the CD Player using the supplied DIN sleeve and rear support bracket. When considering your mounting location, make sure the unit will be leveled. If you cannot mount the CD Player level, due to your vehicles design, make sure there is no more than a 30 degree tilt. Keeping this in mind will assure proper CD play and overall reliability.

DIN SLEEVE MOUNTING

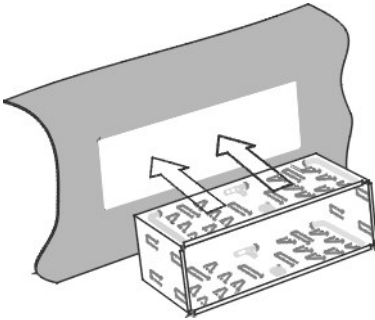

Insert the mounting sleeve into a standard DIN cutout in the dash kit, dashboard or Console.

Bend the mounting tabs of the sleeve with a screwdriver to secure the bracket firmly in place.

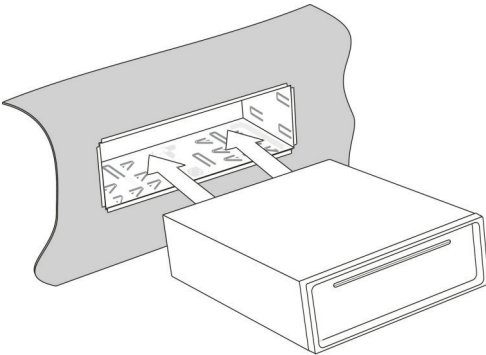
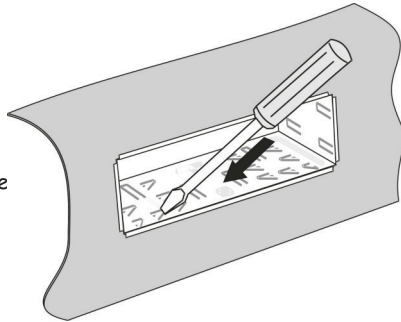

Insert the CD Player in the mounting sleeve until it locks.

Attach the back brace to the CD player using the supplied hardware. Then attach the other end of the brace to a firm mounting surface (i.e. Dash brace, fire wall, e.t.c.) This will brace the back of the CD player to ensure solid mounting to prevent theft and provide optimal CD play.

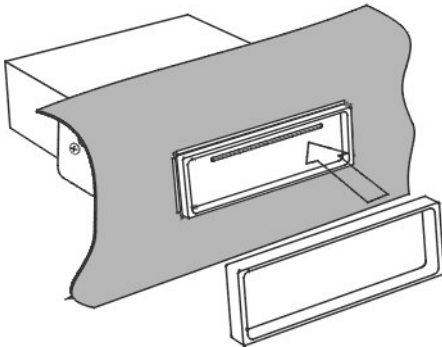
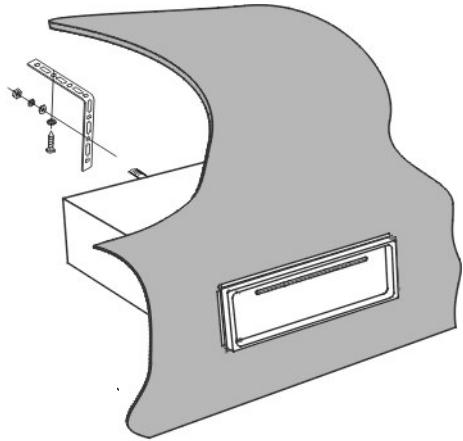

Once the CD player is secured, fit the trim ring over outside edge of the radio until it snaps into place.

To Attach the Face Plate:

Basically, the face plate should be attached to the unit in the reverse order of removal.

- ① Hold the right side of the plate with the plate facing down.
First attach the left side of the plate to the unit by inserting the hole into the left holder.
- ② Then slightly push the plate to the left before attaching the right side hole into the right holder.
- ③ Finally push up the face plate until click sound is heard.

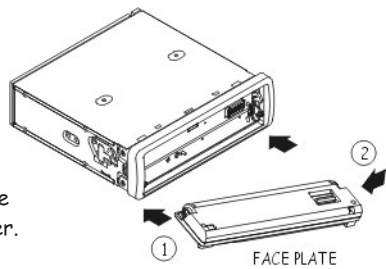

ISO/DIN MOUNTING

If you own a Japanese vehicle, you can use the standard ISO/DIN mounting screw holes on the side of the CD player to attach to the existing factory mounting bracket, without using the provided DIN sleeve.

- Remove the factory ISO/DIN mounting bracket from the car along with the factory radio.
- Remove the factory radio from the bracket by unscrewing the two Phillips screws on each side of the radio paying close attention to their screw positions and saving the screws to mount the CD player.
- Remove the two spring clips from each side of the CD player by removing the screws. These clips are not used in ISO/DIN mounting method and must be removed to expose the ISO/DIN mounting holes.
- Also remove the detachable face and rectangular trim ring from the CD player and mount the CD player to the factory ISO/DIN bracket using the screws that you removed from the factory radio.
- Connect the wire harness and antenna plug to the back of the CD player. Then mount the factory ISO-DIN bracket to the car.

Note: It is not necessary to attach the outer rectangular trim ring for ISO/DIN mounting method.

REMOVING THE CD PLAYER

- To remove the CD player from an ISO/DIN mount, follow the above mounting procedure in reverse order.
- To remove the CD player from a sleeve mount, use the pair of keys provided.

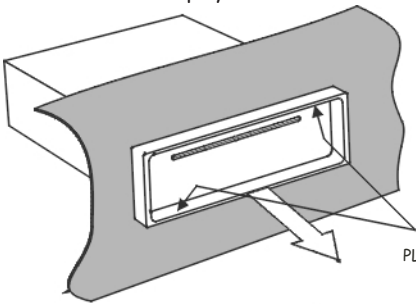

Remove the rectangular trim ring by applying pressure with your finger tips, then gently pull out away from the dash.

PLACE FINGER TIPS HERE

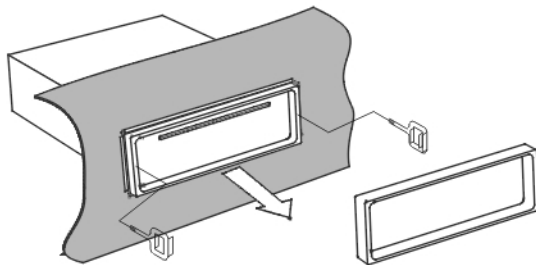

Insert the provided removal key into the opening on each side of the CD player. Push the keys inward until they snap in place. Firmly grab the keys and slowly pull the CD player out away from the dash.

LOCATION AND FUNCTION OF CONTROLS

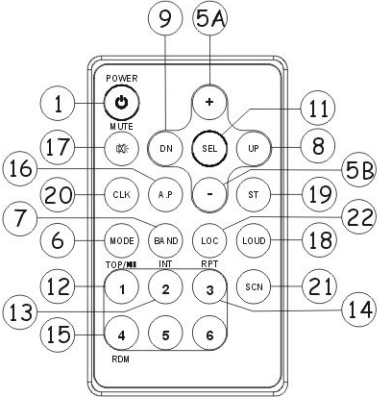
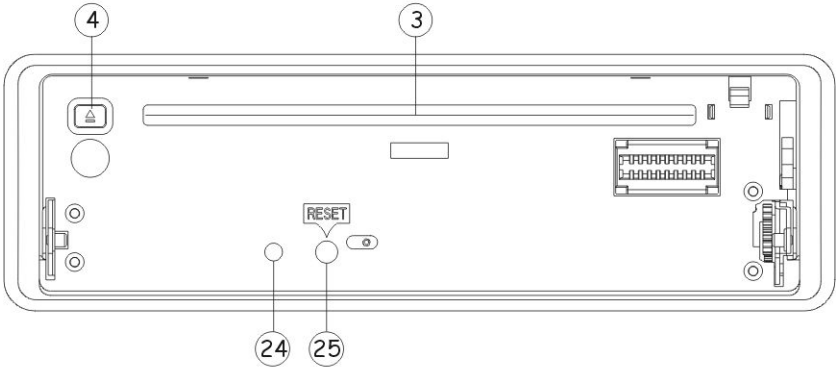
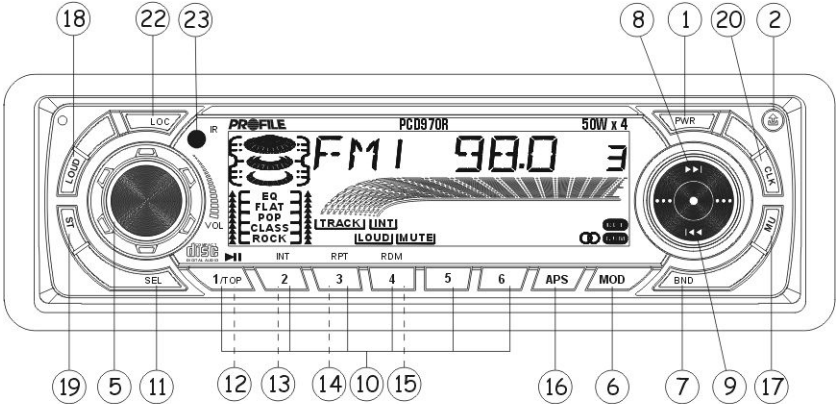

① **POWER**

To turn "ON" the unit, press any button except the OPEN button.
To turn "OFF" the unit, press the PWR button for more than 2 seconds.

② **FLIP DOWN PANEL**

Press the OPEN button to flip down the faceplate. This will allow you to insert or eject a CD and also remove the faceplate.

③ **CD PLAY**

To play a CD, press the OPEN button to flip down the face plate exposing the CD inserting slot. Gently insert the CD into the slot with the label side facing up. The disc will automatically be loaded into the unit and start playing the first track of the disc. The digital display will indicate the track number.

④ **EJECT CD**

To remove a CD once inserted, press the OPEN button to flip down the faceplate and press the (▲) button located on the left hand side of the CD inserting slot. Once the CD is ejected, the unit switches to radio mode.

⑤ **VOLUME UP/DOWN**

Rotate the VOL knob in clockwise direction to raise the system's volume and in counter clockwise direction to lower the system's volume.

Note: For remote control, press the + button to raise the volume and press the - button to lower the volume.

⑥ **MODE**

Press the MOD button to change among tuner (radio), CD (if disc is loaded), and auxiliary input playing mode.



⑦ **BAND**

Under radio mode press the BND button to change between three FM bands and two AM bands.



⑧⑨ RADIO TUNE & CD TRACK UP/DOWN, CD FAST FORWARD/REWIND

Under radio mode, press the ►►⑧ or ◀◀⑨ button momentarily and repeatedly to change the frequency number up or down one step. Under SEEK 1 mode, press and hold the ►►⑧ or ◀◀⑨ button for more than 2 seconds to seek to the next or previous clear station. Under SEEK 2 mode, press and hold the ►►⑧ or ◀◀⑨ button to speedily change stations up or down. Changing stations will stop once the button is released. (Please refer to “SEEK” on page 13 on how to set the seek mode between SEEK 1 and SEEK 2.)

In CD play mode, press the ►►⑧ or ◀◀⑨ button to move to the next or previous track.

In CD play mode, press and hold the ►►⑧ or ◀◀⑨ button to fast forward or fast reverse through the song. The CD resumes playing when the button is released.

⑩ PRESET STATIONS

There are 6 numbered buttons to store into memory and recall stations for each band. Select a band (if needed) as explained in ⑦. Tune to a radio station that you wish to store. Select, press, and hold a preset numbered button for 2 seconds until you hear a beep indicating that the station has been stored in memory. To recall a preset station, simply push the numbered preset button.

⑪ FUNCTION SELECT

SEL button allows you to display different functions for adjustments. Press the SEL button momentarily and repeatedly to move the display from Volume, Bass, Treble, Balance, and Fader functions. Use the VOL knob ⑤ to adjust the selected mode. When the mode has not been adjusted for several seconds, display and mode returns to normal radio or CD operation.

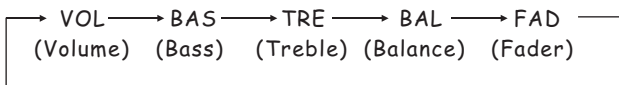

VOLUME - Press the SEL button once. Adjust the volume level using the VOL knob ⑤.

BASS - Press the SEL button twice. Adjust the bass level using the VOL knob ⑤.

TREBLE - Press the SEL button three times. Adjust the treble level using the VOL knob ⑤.

BALANCE - Press the SEL button four times. Adjust the sound balance between left and right speakers using the VOL knob ⑤.

FADER - Press the SEL button five times. Adjust the sound balance between front and rear speakers using the VOL knob ⑤.

Press the SEL button for more than 2 seconds to display additional set of functions for adjustments, such as DSP, Beep On/Off, Seek 1 or 2, Clock 12 or 24, and Volume Last/Adjust.

DSP - The unit is equipped with 4 preset equalization modes. Press the SEL button for more than 2 seconds to display DSP OFF. Then turn the VOL knob (5) in the clockwise direction to choose one of 4 following preset EQ's in the following order.

When using preset EQ modes you will not have access to Bass and Treble settings.



BEEP - The beep sound when you press a button on the unit can be turned on or off. Press the SEL button for more than 2 seconds to display the DSP function. Press the SEL button again momentarily to display BEEP ON/OFF. Then use the VOL knob (5) to turn on/off the beep sound.

SEEK - The unit is equipped with two types of seeks, SEEK 1 and SEEK 2, for radio stations. Press the SEL button for more than 2 seconds to display the DSP function. Press the SEL button twice momentarily to display SEEK 1 or 2. Then use the VOL knob (5) to switch between SEEK 1 and SEEK 2. (This adjustment is only available during radio operation)

SEEK 1 mode: Pressing ►► (8) or ◀◀ (9) button for more than 2 seconds will seek up or down to the next strong station during radio operation.

SEEK 2 mode: Pressing ►► (8) or ◀◀ (9) button continuously will speedily change station up or down until the button is released.

CLOCK - The unit is equipped with two types of clock formats, 12 hour and 24 hour. Press the SEL button for more than 2 seconds to display the DSP function. Press the SEL button three times momentarily to display CLOCK 12 or 24. Then use the VOL knob (5) to choose between 12 and 24.

SET VOL - A certain volume level can be set to come on when the unit is turned on or can be set to come on at the same last level before the unit was turned off. Press the SEL button for more than 2 seconds to display the DSP function. Press the SEL button four times momentarily to display VOL LAST/ADJ. Use the VOL knob (5) to choose between VOL LAST and VOL ADJ. To set the volume to a certain level, press the SEL button momentarily when VOL ADJ is displayed. Then use the VOL knob (5) to adjust to certain volume level when A-VOL is displayed.

12 CD TOP/PAUSE

In CD play mode, press the TOP ►|| (12) button to pause CD play. Press again to resume normal play.

In CD play mode, press the TOP ►|| (12) button for more than 2 seconds to go back to the top of the disc and play the first track.

13 CD SCAN

In CD play mode, press the INT (13) button to turn on intro playing first 10 seconds of each track. When wish to listen to the whole track during intro mode, press the button again to turn off intro.

14 REPEAT PLAY

In CD play mode, press the RPT (14) button to continuously playing the current track. Press it again to cancel the repeat feature.

15 RANDOM PLAY

In CD play mode, press the RDM (15) button to play all tracks of the disc in random sequence. Press it again to cancel random play.

16 AUTOMATIC STORING & PRESET SCANNING

In radio mode, press and hold the APS (16) button for more than 2 seconds to activate the automatic storing function. Once activated, the radio starts searching for first 6 strong signaled stations and stores them into the preset memory. After completion, the radio will tune back to the first preset memory station.

In radio mode, press the APS (16) button for momentarily to activate the preset scanning function. Once activated, the radio starts scanning all preset memory stations for few seconds at a time while the preset memory number flashes on the LCD. Pressing the button again will stop the scan.

17 MUTE

Press the MU button to silence the system. Press a second time to resume listening.

18 LOUDNESS

Press the LOUD button once to enhance the bass effect.
Press again to cancel the loudness effect.

19 MONO/STEREO

Monaural (Mono) or Stereo mode can be selected for FM tuner's reception. For best quality sound, stereo mode should be selected. However, Mono mode can be selected to help the reception of distant radio stations. Press the ST button to select between Mono and Stereo modes.

⑳ CLOCK

Press the CLK button to display the time on the LCD for 5 seconds. To adjust the time, press and hold the CLK button until the hour flashes and use the VOL ⑤ knob to adjust the hour. Press and hold the CLK button again until the minute flashes and use the VOL ⑤ knob to adjust the minute.

㉑ RADIO SCAN (Only from Remote)

Pressing the SCN button from the remote control, the unit will scan and search for the next strong station while playing each station for 5 seconds with station number flashing. Pressing the SCN button again will stop the radio scan.

㉒ LOCAL/DX

This button is used to control the sensitivity of the FM radio tuner while searching for a station. When the radio is powered on, the local mode is off by default. Press the LOC button to turn on the local mode only to receive the strongest stations.

㉓ INFRARED REMOTE CONTROL SENSOR

㉔ SECURITY LED

Designed as a theft deterrent, the red LED will flash when the unit is turned off and face plate removed.

㉕ RESET

The reset button should be pressed when installation is complete and also when all buttons do not operate.

MAINTENANCE OF REMOTE CONTROL

- Before using the remote control, the insulating patch must be removed. This patch was installed to insulate the battery from draining until ready to use.

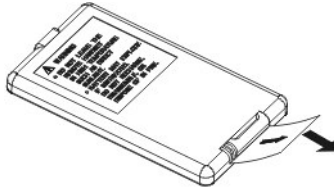

BATTERY INFORMATION:

Lithium Battery: CR2025 3V

Battery Life: Approximately 6 months.

Replacing the Battery from the Remote Control:

- 1) Turn over the remote control so the rear side of the remote is facing up.
- 2) Remove the battery holder by pressing the locking tab with your thumb and pulling it out.
- 3) Replace the battery with the same type and the “ + ” side facing up.
- 4) Gently push in the holder until securely locked into place.

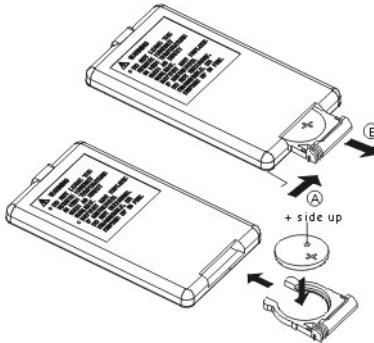

WARNING:

- Do not recharge, disassemble or dispose of in fire.
- Battery leakage may cause damage to the unit.
- To avoid the risk of accident, keep batteries out of reach of children.

TROUBLE SHOOTING THE SYSTEM

The following chart will help in solving most problems that may occur. Should any problem persist after you have made these checks, please consult your nearest Profile retailer. Before going through this check list, refer back to the wiring and operating procedures.

ERROR CODES		
E 1~ E 10	The unit cannot be operated because of trouble. Press the "RESET" button (25). If the indicator still appears after pressing the "RESET" button (25), your unit needs repair. Please refer to the warranty section of this manual for details on getting the unit serviced.	
SYMPTOM	CAUSE	SOLUTION
No Power	New installation.	Press the RESET (25) button.
	The vehicle's ignition switch is not on.	Turn the ignition switch to the accessory position. If there is still no power, check the fuses at the vehicle's fuse block or the radio's fuse leads.
	The fuse is blown.	Replace the fuse with another fuse of the same recommended value
Disc cannot be loaded or ejected.	There is a disc already in the player.	Remove the disc in the player, then put in the new one.
	You are trying to put the compact disc in upside down.	Insert the compact disc with the label facing up.
	The compact disc is extremely dirty or defective.	Clean the compact disc with a compact disc cleaning solution or replace the defective compact disc.
	The temperature in the car is too hot.	Cool the inside of the vehicle, then try again.
	Condensation build-up on the inside of the unit.	Leave the disc player off and turn the vehicle's air conditioner on to remove the condensation build-up inside the unit.
No sound.	The volume control is all the way down.	Adjust the volume control.
	The speakers are bad.	Test the speakers to determine if they need replacing.
The function buttons do not work.	The built-in microprocessor is operating incorrectly.	Remove the disc, then re-insert it. Press the reset button (25).

SYMPTOM	CAUSE	SOLUTION
The compact disc skips.	The installation angle is greater than 30 degrees	Adjust the angle of the unit to less than 30 degrees
	The disc player is installed incorrectly	Check to see if the unit is fastened securely with the back brace supporting the rear of the unit.
	The compact disc is extremely dirty or defective disc.	Clean the compact disc with a compact disc cleaning solution or replace the defective compact disc.
	Condensation build-up on the inside of the unit.	Leave the disc player off and turn the vehicle's air conditioner on to remove the condensation build-up inside the unit.
The radio does not work. The Radio station automatic selection does not work.	The antenna is not connected or the antenna is bad.	Check the antenna and connection to insure proper performance.
	The signals in your listening area are weak.	Select stations manually and make sure the tuner is in the distant stereo mode.

SPECIFICATIONS

GENERAL

Power Supply Requirements.....	DC 12 Volts, Negative Ground
Chassis Dimensions	7" (W) x 6 1/2" (D) x 2" (H)
Tone Controls.....	
Bass @ 100Hz.....	+10dB / -10 dB
Treble @ 10Khz.....	+10dB / -10 dB
Equalizer.....	4 Presets
Maximum Output Power.....	50W x 4
RMS Output Power.....	30W x 4
Maximum Current Consumption.....	15 Ampere
Fuses	
Memory (Constant).....	15 Ampere
Accessory (Switched).....	0.5 Ampere
RCA line out voltage.....	3.7 V

CD PLAYER

Signal to Noise Ratio.....	>85dB
Channel Separation.....	>80dB
Frequency Response.....	5Hz ~ 20Khz
Usable Disc.....	CD/CD-R/CD-RW Discs

RADIO

FM

Frequency Coverage.....	87.5 to 107.9MHz(US)
IF.....	10.7MHz
Station Presets.....	18

AM

Frequency Coverage.....	530 to 1710KHz(US)
IF.....	450KHz
Station Presets.....	12

Due to continuing product improvement, specifications subject to change without notice.

PROFILE[®] LIMITED WARRANTY

Profile Consumer Electronics, Inc. warrants this product to be free from defects in material and workmanship for a period of One (1) Year from the date of sale to the original consumer purchaser. If this product is proven to be defective within this one year period, Profile will repair it when said product is returned, with a copy of the dated sales receipt, freight prepaid to Profile.

This warranty is valid only in the United States. This warranty does not cover any expense incurred in the removal and/or re-installation of this product. This warranty does not cover any Profile product damaged by accident, misuse, abuse, improper line voltage, fire, water, lightning, or other acts of God. This warranty is void if any parts and/or service is/are furnished by anyone other than Profile. This warranty is void if the factory applied serial number is altered or removed from the product.

This warranty does not cover cartons, cases, batteries, broken or marred cabinets, magnetic tapes, or any other accessories used in connection with this product or consequential damages due to a defect in the product.

Any implied warranties, including fitness for use and merchantability, are limited in duration to the period of the express warranty set forth above. No person is authorized to assume for Profile any other liability in connection with the sale of the product. Profile expressly disclaims liability for incidental and consequential damages that might be caused by this product. The remedies provided under this warranty are exclusive and lieu of all others.

This warranty gives you specific legal rights. You may have other rights which vary from state to state or province to province. Some states or provinces do not allow limitation on how long warranties last, so the above may not apply to you. Additionally, some states/provinces do not allow the exclusion to limitation of consequential or incidental damages, so the above limitation or exclusion may not apply to you.

* In the space below, record the serial number that is located on the back of the unit along with the purchase date and location.

Model Number _____ Serial Number _____

Purchase Date _____ Where Purchased _____

RETAIN YOUR SALES RECEIPT ALONG WITH THIS CARD. IT IS YOUR ONLY VALID DOCUMENT TO RECEIVE WARRANTY SERVICE.

PROFILE® WARRANTY REPAIR POLICY

In the unlikely event of product failure, the following procedures should be followed

- 1) The unit must be under the 1-year warranty period.
- 2) The unit must have no physical damage.
- 3) A copy of the original proof of purchase must be sent with the unit.
- 4) Include a brief description of the problem or failure with the unit.
- 5) Include the return street address and daytime telephone number.
- 6) Allow 2~3 weeks for repair (this period includes shipping time).

Send unit to: **PROFILE CONSUMER ELECTRONICS, INC.**
 15060 SHOEMAKER AVE
 SANTA FE SPRINGS, CA 90670
 TEL: (562) 404-9393

Note: All units failing to meet the above requirements will be subject to a charge and or may not be repaired.



PROFILE CONSUMER ELECTRONICS, INC.
15060 SHOEMAKER AVE
SANTA FE SPRINGS, CA 90670
TEL: (562)404-9393 FAX: (562)404-9433
WWW.PROFILEUSA.COM