

Operation Manual

Mode d'emploi

Multi-CD control High power CD/MP3 player with FM/AM tuner

Syntoniseur FM/AM et lecteur de CD/MP3, "Puissance élevée", avec contrôleur pour lecteur de CD à chargeur

DEH-P4500MP

English

Français

Español

SUPER  **TUNER III** 

Thank you for buying this Pioneer product.

Please read through these operating instructions so you will know how to operate your model properly. *After you have finished reading the instructions, put them away in a safe place for future reference.*

01 Before You Start

- For Canadian model **5**
- Information to User **5**
- About this unit **5**
- About this manual **5**
- After-sales service for Pioneer products **5**
- Product registration **6**
- Precautions **6**
- Features **6**
- Use and care of the remote control **6**
 - Installing the battery **6**
 - Using the remote control **7**
- About the XM READY mark **7**
- Protecting your unit from theft **7**
 - Removing the front panel **8**
 - Attaching the front panel **8**

02 What's What

- Head unit **9**
- Remote control **10**

03 Power ON/OFF

- Turning the unit on **11**
- Selecting a source **11**
- Turning the unit off **11**

04 Tuner

- Listening to the radio **12**
- Introduction of advanced tuner operation **13**
- Storing and recalling broadcast frequencies **13**
- Tuning in strong signals **13**
- Storing the strongest broadcast frequencies **14**

05 Built-in CD Player

- Playing a CD **15**

- Introduction of advanced built-in CD player operation **16**
- Repeating play **16**
- Playing tracks in a random order **16**
- Scanning tracks of a CD **16**
- Pausing CD playback **17**
- Selecting the search method **17**
- Searching every 10 track in the current disc **17**
- Using disc title functions **18**
 - Entering disc titles **18**
 - Displaying disc titles **18**
- Using CD TEXT functions **19**
 - Displaying titles on CD TEXT discs **19**
 - Scrolling titles in the display **19**

06 MP3 Player

- Playing a MP3 **20**
- Introduction of advanced built-in CD player (MP3) operation **21**
- Repeating play **21**
- Playing tracks in a random order **22**
- Scanning folders and tracks **22**
- Pausing MP3 playback **23**
- Selecting the search method **23**
- Searching every 10 track in the current folder **23**
- Switching the ID3 tag display on MP3 disc **23**
- Displaying text information on MP3 disc **24**
- Scrolling text information in the display **24**

07 Multi-CD Player

- Playing a CD **25**
- 50-disc multi-CD player **25**
- Introduction of advanced multi-CD player operation **26**
- Repeating play **26**

Playing tracks in a random order	26
Scanning CDs and tracks	27
Pausing CD playback	27
Using ITS playlists	27
– Creating a playlist with ITS programming	27
– Playback from your ITS playlist	28
– Erasing a track from your ITS playlist	28
– Erasing a CD from your ITS playlist	29
Using disc title functions	29
– Entering disc titles	29
– Displaying disc titles	30
Using CD TEXT functions	30
– Displaying titles on CD TEXT discs	30
– Scrolling titles in the display	30
Using compression and bass emphasis	30

08 Audio Adjustments

Introduction of audio adjustments	31
Using balance adjustment	31
Using the equalizer	31
– Recalling equalizer curves	32
– Adjusting equalizer curves	32
– Fine adjusting equalizer curve	32
Adjusting loudness	33
Front image enhancer (F.I.E.)	33
Adjusting source levels	34

09 Initial Settings

Adjusting initial settings	35
Setting the clock	35
Switching the warning tone	35
Switching the auxiliary setting	35

10 Other Functions

Turning the clock display on or off	36
-------------------------------------	----

Using the AUX source	36
– Selecting AUX as the source	36
– Setting the AUX title	36
Introduction of XM operation	37
– XM operation	37
– Switching the XM channel select setting	37

Additional Information

Understanding built-in CD player error messages	38
CD player and care	38
CD-R/CD-RW discs	39
MP3 files	39
About folders and MP3 files	40
Terms	41
Specifications	42



Dear Customer:

Selecting fine audio equipment such as the unit you've just purchased is only the start of your musical enjoyment. Now it's time to consider how you can maximize the fun and excitement your equipment offers. This manufacturer and the Electronic Industries Association's Consumer Electronics Group want you to get the most out of your equipment by playing it at a safe level. One that lets the sound come through loud and clear without annoying blaring or distortion—and, most importantly, without affecting your sensitive hearing.

Sound can be deceiving. Over time your hearing "comfort level" adapts to higher volumes of sound. So what sounds "normal" can actually be loud and harmful to your hearing. Guard against this by setting your equipment at a safe level BEFORE your hearing adapts.

To establish a safe level:

- Start your volume control at a low setting.
- Slowly increase the sound until you can hear it comfortably and clearly, and without distortion.

Once you have established a comfortable sound level:

- Set the dial and leave it there.

Taking a minute to do this now will help to prevent hearing damage or loss in the future. After all, we want you listening for a lifetime.

We Want You Listening For A Lifetime

Used wisely, your new sound equipment will provide a lifetime of fun and enjoyment. Since hearing damage from loud noise is often undetectable until it is too late, this manufacturer and the Electronic Industries Association's Consumer Electronics Group recommend you avoid prolonged exposure to excessive noise. This list of sound levels is included for your protection.

Decibel

<u>Level</u>	<u>Example</u>
30	Quiet library, soft whispers
40	Living room, refrigerator, bedroom away from traffic
50	Light traffic, normal conversation, quiet office
60	Air conditioner at 20 feet, sewing machine
70	Vacuum cleaner, hair dryer, noisy restaurant
80	Average city traffic, garbage disposals, alarm clock at two feet

THE FOLLOWING NOISES CAN BE DANGEROUS UNDER CONSTANT EXPOSURE

90	Subway, motorcycle, truck traffic, lawn mower
100	Garbage truck, chain saw, pneumatic drill
120	Rock band concert in front of speakers, thunderclap
140	Gunshot blast, jet plane
180	Rocket launching pad

Information courtesy of the Deafness Research Foundation.



Before You Start

For Canadian model

This Class B digital apparatus complies with Canadian ICES-003.



Information to User

Alteration or modifications carried out without appropriate authorization may invalidate the user's right to operate the equipment.



About this unit

The tuner frequencies on this unit are allocated for use in North America. Use in other areas may result in improper reception.



Important (Serial number)

The serial number is located on the bottom of this unit. For your own security and convenience, be sure to record this number on the enclosed warranty card. 

About this manual

This unit features a number of sophisticated functions ensuring superior reception and operation. All the functions have been designed for the easiest possible use, but many are not self-explanatory. This operation manual will help you benefit fully from this product's potential and to maximize your listening enjoyment.

We recommend that you familiarize yourself with the functions and their operation by reading through the manual before you begin

using this unit. It is especially important that you read and observe precautions on the next page and in other sections. 

After-sales service for Pioneer products

Please contact the dealer or distributor from where you purchased this unit for after-sales service (including warranty conditions) or any other information. In case the necessary information is not available, please contact the companies listed below:

Please do not ship your unit to the companies at the addresses listed below for repair without advance contact.

U.S.A.

Pioneer Electronics (USA) Inc.
CUSTOMER SUPPORT DIVISION
P.O. Box 1760
Long Beach, CA 90801-1760
800-421-1404

CANADA

Pioneer Electronics of Canada, Inc.
CUSTOMER SATISFACTION DEPARTMENT
300 Allstate Parkway
Markham, Ontario L3R 0P2
(905) 479-4411
1-877-283-5901

For warranty information please see the Limited Warranty sheet included with this unit. 

Product registration

Visit us at the following site:

<http://www.pioneerelectronics.com>

- 1 Register your product. We will keep the details of your purchase on file to help you refer to this information in the event of an insurance claim such as loss or theft.
- 2 Receive updates on the latest products and technologies.
- 3 Download owner's manuals, order product catalogues, research new products, and much more.

Precautions

CAUTION:
USE OF CONTROL OR ADJUSTMENT OR PERFORMANCE OF PROCEDURES OTHER THAN THOSE SPECIFIED HEREIN MAY RESULT IN HAZARDOUS RADIATION EXPOSURE.

CAUTION:
THE USE OF OPTICAL INSTRUMENTS WITH THIS PRODUCT WILL INCREASE EYE HAZARD.

- Keep this manual handy as a reference for operating procedures and precautions.
- Always keep the volume low enough so you can hear sounds outside of the car.
- Protect this product from moisture.
- If the battery is disconnected or discharged, the preset memory will be erased and must be reprogrammed.

Features

CD playback

Music CD/CD-R/CD-RW playback is possible.

MP3 file playback

It is possible to play back MP3 files recorded on CD-ROM/CD-R/CD-RW (ISO9660 Level 1/ Level 2 standard recordings).

- Supply of this product only conveys a license for private, non-commercial use and does not convey a license nor imply any right to use this product in any commercial (i.e. revenue-generating) real time broadcasting (terrestrial, satellite, cable and/or any other media), broadcasting/streaming via internet, intranets and/or other networks or in other electronic content distribution systems, such as pay-audio or audio-on-demand applications. An independent license for such use is required. For details, please visit <http://www.mp3licensing.com>.

Use and care of the remote control

Installing the battery

Slide the tray out on the back of the remote control and insert the battery with the plus (+) and minus (-) poles pointing in the proper direction.

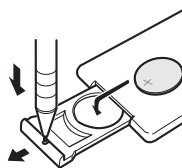

Before You Start

WARNING

Keep the battery out of the reach of children. Should the battery be swallowed, immediately consult a doctor.

CAUTION

- Use only one **CR2025 (3 V)** lithium battery.
- Remove the battery if the remote control is not used for a month or longer.
- Do not recharge, disassemble, heat or dispose of the battery in fire.
- Do not handle the battery with metallic tools.
- Do not store the battery with metallic materials.
- In the event of battery leakage, wipe the remote control completely clean and install a new battery.
- When disposing of used batteries, please comply with governmental regulations or environmental public institution's rules that apply in your country/area.

Using the remote control

Point the remote control in the direction of the front panel to operate.

Important

- Do not store the remote control in high temperatures or direct sunlight.
- The remote control may not function properly in direct sunlight.
- Do not let the remote control fall onto the floor, where it may become jammed under the brake or accelerator pedal. 

About the XM READY mark



The XM READY mark printed on the front panel indicates that the Pioneer XM tuner (sold separately) can be controlled by this unit. Please inquire to your dealer or nearest authorized Pioneer service station regarding the XM tuner that can be connected to this unit. For XM tuner operation, please refer to the XM tuner owner's manual.

Notes

- XM Satellite Radio is developing a new band of radio in the U.S.A.



The system will use direct satellite-to-receiver broadcasting technology to provide listeners in their cars and at home with crystal-clear sound seamlessly from coast to coast. XM will create and package up to 100 channels of digital-quality music, news, sports, talk and children's programming.

- The XM name and related logos are trademarks of XM Satellite Radio Inc. 

Protecting your unit from theft

The front panel can be detached from the head unit and stored in the protective case provided to discourage theft.

- If the front panel is not detached from the head unit within five seconds of turning off the ignition, a warning tone will sound.
- You can turn off the warning tone. See *Switching the warning tone* on page 35.

Important

- Never use force or grip the display and the buttons tightly when removing or attaching.
- Avoid subjecting the front panel to excessive shocks.
- Keep the front panel out of direct sunlight and high temperatures.

Removing the front panel

1 Press **OPEN** to open the front panel.

2 Grip the left side of the front panel and pull it gently outward.

Take care not to grip it tightly or drop it.

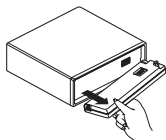

3 Put the front panel into the protective case provided for safe keeping.

Attaching the front panel

- Replace the front panel by holding it upright to this unit and clipping it securely into the mounting hooks.

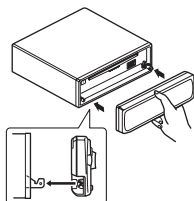

What's What

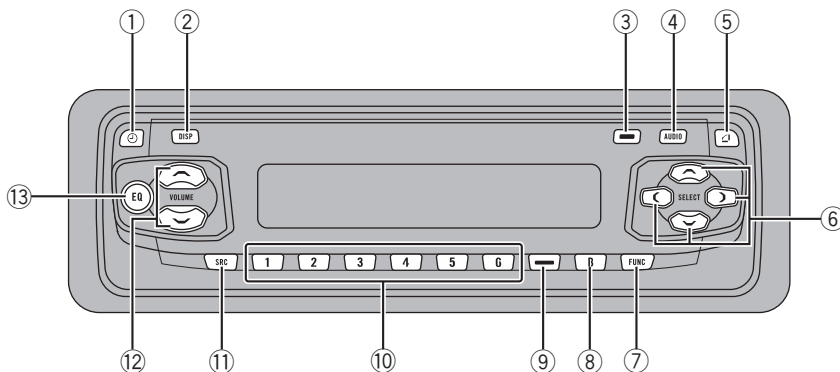

Head unit

- ① **CLOCK button**
Press to change to the clock display.
- ② **DISPLAY button**
Press to select different displays.
- ③ **PAUSE button**
Press to turn pause on or off.
- ④ **AUDIO button**
Press to select various sound quality controls.
- ⑤ **OPEN button**
Press to open the front panel.
- ⑥ **▲/▼/◀/▶ buttons**
Press to do manual seek tuning, fast forward, reverse and track search controls. Also used for controlling functions.
- ⑦ **FUNCTION button**
Press to select functions.
- ⑧ **BAND button**
Press to select among three FM and one AM bands and cancel the control mode of functions.
- ⑨ **LOUDNESS button**
Press to turn loudness on or off.
- ⑩ **1-6 buttons**
Press for preset tuning and disc number search when using a multi-CD player.
- ⑪ **SOURCE button**
This unit is turned on by selecting a source. Press to cycle through all of the available sources.
- ⑫ **VOLUME**
Press to increase or decrease the volume.
- ⑬ **EQ button**
Press to select various equalizer curves.

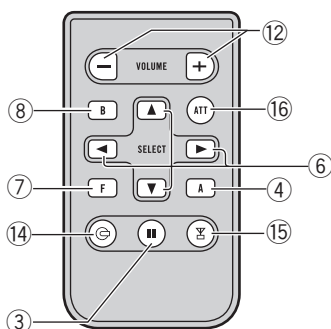

Remote control

Operation is the same as when using the button on the head unit. See the explanation of the head unit about the operation of each button with the exception of **ATT**, which is explained below.

⑭ CD button

Press to select the built-in or multi-CD player as the source.

⑮ TUNER button

Press to select the tuner as the source.

⑯ ATT button

Press to quickly lower the volume level, by about 90%. Press once more to return to the original volume level. 

Power ON/OFF

Turning the unit on

● Press SOURCE to turn the unit on.

When you select a source the unit is turned on. 

Selecting a source

You can select a source you want to listen to. To switch to the built-in CD player, load a disc in this unit (refer to page 15).

1 When using the head unit, press SOURCE to select a source.

Press **SOURCE** repeatedly to switch between the following sources:

Built-in CD player—Television—Tuner—XM tuner—Multi-CD player—External unit 1—External unit 2—AUX

2 When using the remote control, press TUNER or CD to select a source.

Press each button repeatedly to switch between the following sources:

TUNER: Television—Tuner—XM tuner—Sources off

CD: Built-in CD player—Multi-CD player—Sources off



Notes

- In the following cases, the sound source will not change:
 - When a unit corresponding to each source is not connected to this unit.
 - When no disc is set in this unit.
 - When no magazine is set in the multi-CD player.
 - When the AUX (auxiliary input) is set to off (refer to page 35).
- External unit refers to a Pioneer product (such as one available in the future) that, although incompatible as a source, enables control of basic functions by this unit. Two external units

can be controlled by this unit. When two external units are connected, the allocation of them to external unit 1 or external unit 2 is automatically set by this unit.

- When this unit's blue/white lead is connected to the car's auto-antenna relay control terminal, the car's antenna extends when this unit's source is turned on. To retract the antenna, turn the source off. 

Turning the unit off

● Press SOURCE and hold until the unit turns off.

Listening to the radio

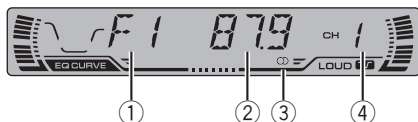

These are the basic steps necessary to operate the radio. More advanced tuner operation is explained starting on the next page.

① Band indicator

Shows which band the radio is tuned to, AM or FM.

② Frequency indicator

Shows to which frequency the tuner is tuned.

③ Stereo (Ⓢ) indicator

Shows that the frequency selected is being broadcast in stereo.

④ Preset number indicator

Shows what preset has been selected.

1 Press SOURCE to select the tuner.

Press **SOURCE** until tuner is selected as the source.

2 Use VOLUME to adjust the sound level.

Press to increase or decrease the volume.

3 Press BAND to select a band.

Press **BAND** until the desired band is displayed, **F1**, **F2**, **F3** for FM or **AM**.

4 To perform manual tuning, press ◀ or ▶ with quick presses.

The frequencies move up or down step by step.

5 To perform seek tuning, press and hold ◀ or ▶ for about one second and release.

The tuner will scan the frequencies until a broadcast strong enough for good reception is found.

- You can cancel seek tuning by pressing either ◀ or ▶ with a quick press.
- If you press and hold ◀ or ▶ you can skip broadcasting stations. Seek tuning starts as soon as you release the buttons.



Note

When the frequency selected is being broadcast in stereo the stereo (Ⓢ) indicator will light. ■

Tuner

Introduction of advanced tuner operation

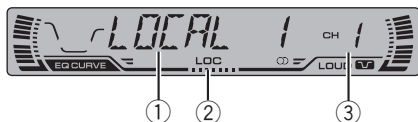

① Function display

Shows the function status.

② LOC indicator

Shows when local seek tuning is on.

③ Preset number indicator

Shows what preset has been selected.

● Press FUNCTION to display the function names.

Press **FUNCTION** repeatedly to switch between the following functions:

BSM (best stations memory)—**LOCAL** (local seek tuning)

- To return to the frequency display, press **BAND**.



Note

If you do not operate the function within about 30 seconds, the display is automatically returned to the frequency display. 

Storing and recalling broadcast frequencies

If you press any of the preset tuning buttons **1–6** you can easily store up to six broadcast frequencies for later recall with the touch of a button.

- When you find a frequency that you want to store in memory press a preset tuning button **1–6** and hold until the preset number stops flashing.

The number you have pressed will flash in the preset number indicator and then remain lit. The selected radio station frequency has been stored in memory.

The next time you press the same preset tuning button **1–6** the radio station frequency is recalled from memory.



Notes

- Up to 18 FM stations, 6 for each of the three FM bands, and 6 AM stations can be stored in memory.
- You can also use **▲** and **▼** to recall radio station frequencies assigned to preset tuning buttons **1–6**. 

Tuning in strong signals

Local seek tuning lets you tune in only those radio stations with sufficiently strong signals for good reception.

1 Press FUNCTION to select LOCAL.

Press **FUNCTION** until **LOCAL** appears in the display.

2 Press ▲ to turn local seek tuning on.

Local seek sensitivity (e.g., **LOCAL 2**) appears in the display.

3 Press ◀ or ▶ to set the sensitivity.

There are four levels of sensitivity for FM and two levels for AM:

FM: **LOCAL 1—LOCAL 2—LOCAL 3—**

LOCAL 4

AM: **LOCAL 1—LOCAL 2**

The **LOCAL 4** setting allows reception of only the strongest stations, while lower settings let you receive progressively weaker stations.

4 When you want to return to normal seek tuning, press ▼ to turn local seek tuning off.

LOCAL:OFF appears in the display. 

Storing the strongest broadcast frequencies

BSM (best stations memory) lets you automatically store the six strongest broadcast frequencies under preset tuning buttons **1–6** and once stored there you can tune in to those frequencies with the touch of a button.

1 Press FUNCTION to select BSM.

Press **FUNCTION** until **BSM** appears in the display.

2 Press ▲ to turn BSM on.

BSM begins to flash. While **BSM** is flashing the six strongest broadcast frequencies will be stored under preset tuning buttons **1–6** in order of their signal strength. When finished, **BSM** stops flashing.

- To cancel the storage process, press ▼.



Note

Storing broadcast frequencies with BSM may replace broadcast frequencies you have saved using **1–6**. 

Built-in CD Player

Playing a CD

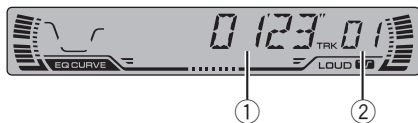

These are the basic steps necessary to play a CD with your built-in CD player. More advanced CD operation is explained starting on the next page.

① Play time indicator

Shows the elapsed playing time of the current track.

② Track number indicator

Shows the track currently playing.

1 Press OPEN to open the front panel.

CD loading slot appears.

- After a CD has been inserted, press **SOURCE** to select the built-in CD player.

2 Insert a CD into the CD loading slot.

Playback will automatically start.

CD loading slot

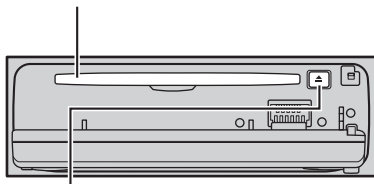

EJECT button

- You can eject a CD by pressing **EJECT**.
- To avoid a malfunction, make sure that no metal object comes into contact with the terminals when the front panel is open.

3 Close the front panel.

4 Use VOLUME to adjust the sound level.

Press to increase or decrease the volume.

5 To perform fast forward or reverse, press and hold ◀ or ▶.

- If you select the search method to **ROUGH**, pressing and holding ◀ or ▶ enables you to search every ten track in the current disc. (Refer to *Selecting the search method* on page 17.)

6 To skip back or forward to another track, press ◀ or ▶.

Pressing ▶ skips to the start of the next track. Pressing ◀ once skips to the start of the current track. Pressing again will skip to the previous track.



Notes

- The built-in CD player plays one, standard, 12-cm or 8-cm (single) CD at a time. Do not use an adapter when playing 8-cm CDs.
- Do not insert anything other than a CD into the CD loading slot.
- If you cannot insert a disc completely or if after you insert a disc the disc does not play, check that the label side of the disc is up. Press **EJECT** to eject the disc, and check the disc for damage before inserting the disc again.
- If the built-in CD player does not operate properly, an error message such as **ERROR-11** may be displayed. Refer to *Understanding built-in CD player error messages* on page 38.
- When a CD TEXT disc is inserted, the disc and track titles begin to scroll to the left automatically. ▣

Introduction of advanced built-in CD player operation

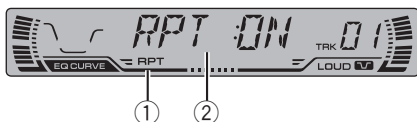

① RPT indicator

Shows when repeat play is turned on.

② Function display

Shows the function status.

● Press **FUNCTION** to display the function names.

Press **FUNCTION** repeatedly to switch between the following functions:

RPT (repeat play)—**RDM** (random play)
—**SCAN** (scan play)—**PAUSE** (pause)
—**FF/REV** (search method)—**TAG** (ID3 tag display)

- To return to the playback display, press **BAND**.

Notes

- When playing audio data (CD-DA), it is not effective even if you turn **TAG** (ID3 tag display) on. (Refer to page 23.)
- If you do not operate the function within about 30 seconds, the display is automatically returned to the playback display. 

Repeating play

Repeat play lets you hear the same track over again.

1 Press **FUNCTION** to select **RPT**.

Press **FUNCTION** until **RPT** appears in the display.

2 Press **▲** to turn repeat play on.

RPT :ON appears in the display. The track currently playing will play and then repeat.

3 Press **▼** to turn repeat play off.

RPT :OFF appears in the display. The track currently playing will continue to play and then play the next track.

Note

If you perform track search or fast forward/reverse, repeat play is automatically cancelled. 

Playing tracks in a random order

Random play lets you play back tracks on the CD in a random order.

1 Press **FUNCTION** to select **RDM**.

Press **FUNCTION** until **RDM** appears in the display.

2 Press **▲** to turn random play on.

RDM :ON appears in the display. Tracks will play in a random order.

3 Press **▼** to turn random play off.

RDM :OFF appears in the display. Tracks will continue to play in order. 

Scanning tracks of a CD

Scan play lets you hear the first 10 seconds of each track on the CD.

1 Press **FUNCTION** to select **SCAN**.

Press **FUNCTION** until **SCAN** appears in the display.

Built-in CD Player

2 Press ▲ to turn scan play on.

SCAN:ON appears in the display. The first 10 seconds of each track is played.

3 When you find the desired track press ▼ to turn scan play off.

SCAN:OFF appears in the display. The track will continue to play.

- If the display has automatically returned to the playback display, select **SCAN** again by pressing **FUNCTION**.



Note

After scanning of a CD is finished, normal playback of the tracks will begin again.

Pausing CD playback

Pause lets you temporarily stop playback of the CD.

1 Press FUNCTION to select PAUSE.

Press **FUNCTION** until **PAUSE** appears in the display.

2 Press ▲ to turn pause on.

PAUSE:ON appears in the display. Play of the current track pauses.

3 Press ▼ to turn pause off.

PAUSE:OFF appears in the display. Play will resume at the same point that you turned pause on.



Note

You can also turn pause on or off by pressing **PAUSE**.

Selecting the search method

You can switch the search method between fast forward/reverse and searching every 10 track.

1 Press FUNCTION to select FF/REV.

Press **FUNCTION** until **FF/REV** appears in the display.

- If the search method **ROUGH** has been previously selected, **ROUGH** will be displayed.

2 Press ◀ or ▶ to select the search method.

Press ◀ or ▶ until the desired search method appears in the display.

- **FF/REV** – Fast forward and reverse
- **ROUGH** – Searching every 10 track

Searching every 10 track in the current disc

If a disc contains over 10 tracks, you can search every 10 track. When a disc contains a lot of tracks, you can roughly search the track you want to play.

1 Select the search method ROUGH.

Refer to *Selecting the search method* on this page.

2 Press and hold ◀ or ▶ to search every 10 track in a disc.

- If a disc contains less than 10 tracks, pressing and holding ▶ recalls the last track of a disc. Also, if the remaining number of tracks after searching every 10 tracks are less than 10, pressing and holding ▶ recalls the last track of a disc.

Built-in CD Player

- If a disc contains less than 10 tracks, pressing and holding ◀ recalls the first track of a disc. Also, if the remaining number of tracks after searching every 10 tracks are less than 10, pressing and holding ◀ recalls the first track of a disc. ◻

Using disc title functions

You can input CD titles and display the title. The next time you insert a CD for which you have entered a title, the title of that CD will be displayed.

Entering disc titles

Disc title input lets you input CD titles up to 8 letters long and up to 48 disc titles into the built-in CD player.

1 Play a CD that you want to enter the title.

2 Press **FUNCTION** and hold until **TITLE IN** appears in the display.

- When playing a CD **TEXT** disc, you cannot switch to **TITLE IN**. The disc title will have already been recorded on a CD **TEXT** disc.

3 Press ▲ or ▼ to select a letter of the alphabet.

Each press of ▲ will display a letter of the alphabet in **A B C ... X Y Z**, numbers and symbols in **1 2 3 ... > []** order. Each press of ▼ will display a letter in the reverse order, such as **Z Y X ... C B A** order.



4 Press ► to move the cursor to the next character position.

When the letter you want is displayed, press ► to move the cursor to the next position and then select the next letter. Press ◀ to move backwards in the display.

5 Move the cursor to the last position by pressing ► after entering the title.

When you press ► one more time, the entered title is stored in memory.

6 Press **BAND** to return to the playback display.



Notes

- Titles remain in memory, even after the disc has been removed from built-in CD player, and are recalled when the disc is reinserted.
- After data for 48 discs has been stored in memory, data for a new disc will overwrite the oldest one.
- If you connect a multi-CD player, you can input disc titles for up to 100 discs.

Displaying disc titles

You can display the title of any disc that has had a disc title entered.

● Press **DISPLAY**.

Press **DISPLAY** repeatedly to switch between the following settings:

Play time—**DISC TTL** (disc title)

When you select **DISC TTL**, the title of the currently playing disc is shown in the display.

- If no title has been entered for the currently playing disc, **NO TITLE** is displayed. ◻

Built-in CD Player

Using CD TEXT functions

Some discs have certain information encoded on the disc during manufacture. These discs may contain such information as the CD title, track title, artist's name and playback time and are called CD TEXT discs. Only these specially encoded CD TEXT discs support the functions listed below.

Displaying titles on CD TEXT discs

- **Press DISPLAY.**

Press **DISPLAY** repeatedly to switch between the following settings:

Play time—**DISC TTL** (disc title)—**ART NAME** (disc artist name)—**TRK TTL** (track title)—**ART NAME** (track artist name)

- If specific information has not been recorded on a CD TEXT disc, **NO XXXX** will be displayed (e.g., **NO D-TTL**).

Scrolling titles in the display

This unit can display the first 8 letters only of **DISC TTL**, **ART NAME**, **TRK TTL** and **ART NAME**. When the recorded information is longer than 8 letters, you can scroll the text to the left so that the rest of the title can be seen.

- **Press DISPLAY and hold until the title begins to scroll to the left.**

The rest of the title will appear in the display.

Playing a MP3

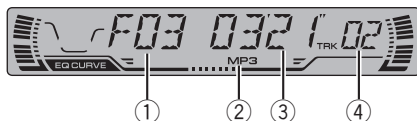

These are the basic steps necessary to play an MP3 with your built-in CD player. More advanced MP3 operation is explained starting on the next page.

① Folder number indicator

Shows the folder number currently playing.

② MP3 indicator

Shows when the MP3 file is playing.

③ Play time indicator

Shows the elapsed playing time of the current track (file).

④ Track number indicator

Shows the track (file) currently playing.

- If a track number 100 to 199 is selected, ► on the left of the track number indicator will light.
- If a track number 200 or more is selected, ► on the left of the track number indicator will blink.

1 Press OPEN to open the front panel.

CD loading slot appears.

- After a CD-ROM has been inserted, press **SOURCE** to select the built-in CD player.

2 Insert a CD-ROM into the CD loading slot.

Playback will automatically start.

CD loading slot

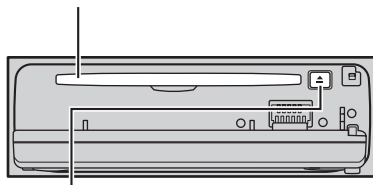

EJECT button

- You can eject a CD-ROM by pressing **EJECT**.
- To avoid a malfunction, make sure that no metal object comes into contact with the terminals when the front panel is open.

3 Close the front panel.

4 Use VOLUME to adjust the sound level.

Press to increase or decrease the volume.

5 Press ▲ or ▼ to select a folder.

- You cannot select a folder that does not have an MP3 file recorded in it.
- To return to folder 01 (ROOT), press and hold **BAND**. However, if folder 01 (ROOT) contains no files, playback commences with folder 02.

6 To perform fast forward or reverse, press and hold ◀ or ▶.

- This is fast forward and reverse operation only for the file being played. This operation is canceled when the previous or next file is reached.
- If you select the search method to **ROUGH**, pressing and holding ◀ or ▶ enables you to search every ten track in the current folder. (Refer to *Selecting the search method* on page 23.)

7 To skip back or forward to another track, press ◀ or ▶.

Pressing ▶ skips to the start of the next track. Pressing ◀ once skips to the start of the current track. Pressing again will skip to the previous track.

MP3 Player



Notes

- When playing discs with MP3 files and audio data (CD-DA) such as CD-EXTRA and MIXED-MODE CDs, both types can be played only by switching mode between MP3 and CD-DA with **BAND**.
- If you have switched between playback of MP3 files and audio data (CD-DA), playback starts at the first track on the disc.
- The built-in CD player can play back an MP3 file recorded on CD-ROM. (Refer to page 39 for files that can be played back.)
- Do not insert anything other than a CD into the CD loading slot.
- There is sometimes a delay between starting up playback and the sound being issued. This is particularly the case when playing back multi-session and many folders. When being read in, **FRMTREAD** is displayed.
- If you cannot insert a disc completely or if after you insert a disc the disc does not play, check that the label side of the disc is up. Press **EJECT** to eject the disc, and check the disc for damage before inserting the disc again.
- Playback is carried out in order of file number. Folders are skipped if they contain no files. (If folder 01 (ROOT) contains no files, playback commences with folder 02.)
- When playing back files recorded as VBR (variable bit rate) files, the play time will not be correctly displayed if fast forward or reverse operations are used.
- If inserted disc contains no files that can be played back, **NO AUDIO** is displayed.
- There is no sound on fast forward or reverse.
- If the built-in CD player does not operate properly, an error message such as **ERROR-11** may be displayed. Refer to *Understanding built-in CD player error messages* on page 38.
- When a MP3 disc is inserted, folder name and file name begin to scroll to the left automatically.

Introduction of advanced built-in CD player (MP3) operation

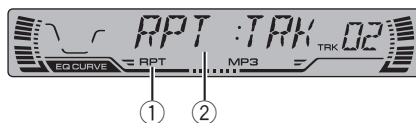

① RPT indicator

Shows when repeat range is selected to current track (file).

② Function display

Shows the function status.

● Press **FUNCTION** to display the function names.

Press **FUNCTION** repeatedly to switch between the following functions:

RPT (repeat play)—**RDM** (random play)

—**SCAN** (scan play)—**PAUSE** (pause)

—**FF/REV** (search method)—**TAG** (ID3 tag display)

- To return to the playback display, press **BAND**.



Note

If you do not operate the function within about 30 seconds, the display is automatically returned to the playback display.

Repeating play

For MP3 playback, there are three repeat play ranges: **FLD** (folder repeat), **TRK** (one-track repeat) and **DSC** (repeat all tracks).

1 Press **FUNCTION** to select **RPT**.

Press **FUNCTION** until **RPT** appears in the display.

2 Press ◀ or ▶ to select the repeat range.

Press ◀ or ▶ until the desired repeat range appears in the display.

- **FLD** – Repeat the current folder
- **TRK** – Repeat just the current track
- **DSC** – Repeat all tracks



Notes

- If you select other folder during repeat play, the repeat play range changes to **DSC**.
- If you perform track search or fast forward/reverse during **TRK**, the repeat play range changes to **FLD**.
- When **FLD** is selected, it is not possible to play back a subfolder of that folder.

Playing tracks in a random order

Random play lets you play back tracks in a random order within the repeat range, **FLD** and **DSC**.

1 Select the repeat range.

Refer to *Repeating play* on the previous page.

2 Press FUNCTION to select RDM.

Press **FUNCTION** until **RDM** appears in the display.

3 Press ▲ to turn random play on.

RDM :ON appears in the display. Tracks will play in a random order within the previously selected **FLD** or **DSC** ranges.

4 Press ▼ to turn random play off.

RDM :OFF appears in the display. Tracks will continue to play in order.



Note

If you turn random play on during **FLD** and then return to the playback display, **FRDM** appears in the display.

Scanning folders and tracks

While you are using **FLD**, the beginning of each track in the selected folder plays for about 10 seconds. When you are using **DSC**, the beginning of the first track of each folder is played for about 10 seconds.

1 Select the repeat range.

Refer to *Repeating play* on the previous page.

2 Press FUNCTION to select SCAN.

Press **FUNCTION** until **SCAN** appears in the display.

3 Press ▲ to turn scan play on.

SCAN:ON appears in the display. The first 10 seconds of each track of the current folder (or the first track of each folder) is played.

4 When you find the desired track (or folder) press ▼ to turn scan play off.

SCAN:OFF appears in the display. The track (or folder) will continue to play.

- If the display has automatically returned to the playback display, select **SCAN** again by pressing **FUNCTION**.



Notes

- After track or folder scanning is finished, normal playback of the tracks will begin again.
- If you turn scan play on during **FLD** and then return to the playback display, **FSCN** appears in the display.

MP3 Player

Pausing MP3 playback

Pause lets you temporarily stop playback of the MP3.

1 Press **FUNCTION** to select **PAUSE**.

Press **FUNCTION** until **PAUSE** appears in the display.

2 Press **▲** to turn pause on.

PAUSE:ON appears in the display. Play of the current track pauses.

3 Press **▼** to turn pause off.

PAUSE:OFF appears in the display. Play will resume at the same point that you turned pause on.



Note

You can also turn pause on or off by pressing **PAUSE**. 

Selecting the search method

You can switch the search method between fast forward/reverse and searching every 10 track.

1 Press **FUNCTION** to select **FF/REV**.

Press **FUNCTION** until **FF/REV** appears in the display.

- If the search method **ROUGH** has been previously selected, **ROUGH** will be displayed.

2 Press **◀** or **▶** to select the search method.

Press **◀** or **▶** until the desired search method appears in the display.

- **FF/REV** – Fast forward and reverse
- **ROUGH** – Searching every 10 track 

Searching every 10 track in the current folder

If the current folder contains over 10 tracks, you can search every 10 track. When the one folder contains a lot of tracks, you can roughly search the track you want to play.

1 Select the search method **ROUGH**.

Refer to *Selecting the search method* on this page.

2 Press and hold **◀** or **▶** to search every 10 track in the current folder.

- If the current folder contains less than 10 tracks, pressing and holding **▶** recalls the last track of the folder. Also, if the remaining number of tracks after searching every 10 tracks are less than 10, pressing and holding **▶** recalls the last track of the folder.
- If the current folder contains less than 10 tracks, pressing and holding **◀** recalls the first track of the folder. Also, if the remaining number of tracks after searching every 10 tracks are less than 10, pressing and holding **◀** recalls the first track of the folder. 

Switching the ID3 tag display on MP3 disc

It is possible to turn the ID3 tag display on MP3 disc on or off, if MP3 disc contains the ID3 tag.

- ID3 tag refers to text information such as track title and artist name.

1 Press **FUNCTION** to select **TAG**.

Press **FUNCTION** until **TAG** appears in the display.

2 Press **▲** to turn ID3 tag display on.

TAG :ON appears in the display.

3 Press ▼ to turn ID3 tag display off.

TAG :OFF appears in the display.



Note

When you turn the ID3 tag on, this unit returns to the beginning of the current track in order to read the text information.

you can scroll the text to the left so that the rest of the text information can be seen.

● Press **DISPLAY** and hold until the text information begins to scroll to the left.

The rest of the text information will appear in the display.

Displaying text information on MP3 disc

Text information recorded on a MP3 disc can be displayed.

● Press **DISPLAY**.

Press **DISPLAY** repeatedly to switch between the following settings:

Play time—**FOLDER** (folder name)—**FILE** (file name)—**TRK TTL** (track title)—**ART NAME** (artist name)—**ALBM TTL** (album title)—**COMMENT** (comment)—Bit rate

- When playing back files recorded as VBR (variable bit rate) files, the bit rate value is not displayed even after switching to bit rate. (**VBR** will be displayed.)

- When you have turned ID3 tag display off, you cannot switch to **TRK TTL**, **ART NAME**, **ALBM TTL** and **COMMENT**.

- If specific information has not been recorded on a MP3 disc, **NO XXXX** will be displayed (e.g., **NO NAME**).

Scrolling text information in the display

This unit can display the first 8 letters only of **FOLDER**, **FILE**, **TRK TTL**, **ART NAME**, **ALBM TTL** and **COMMENT**. When the recorded information is longer than 8 letters,

Multi-CD Player

Playing a CD

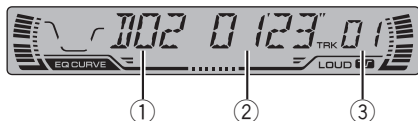

You can use this unit to control a multi-CD player, which is sold separately.

These are the basic steps necessary to play a CD with your multi-CD player. More advanced CD operation is explained starting on the next page.

① Disc number indicator

Shows the disc currently playing.

② Play time indicator

Shows the elapsed playing time of the current track.

③ Track number indicator

Shows the track currently playing.

1 Press SOURCE to select the multi-CD player.

Press **SOURCE** until multi-CD is selected as the source.

2 Use VOLUME to adjust the sound level.

Press to increase or decrease the volume.

3 Select a disc you want to listen to with the 1–6 buttons.

For discs located at 1 to 6, press the corresponding number button.

If you want to select a disc located at 7 to 12, press and hold the corresponding numbers such as **1** for disc 7, until the disc number appears in the display.

■ You can also sequentially select a disc by pressing ▲/▼.

4 To perform fast forward or reverse, press and hold ◀ or ▶.

5 To skip back or forward to another track, press ◀ or ▶.

Pressing ▶ skips to the start of the next track. Pressing ◀ once skips to the start of the current track. Pressing again will skip to the previous track.



Notes

- When the multi-CD player performs the preparatory operations, **READY** is displayed.
- If the multi-CD player does not operate properly, an error message such as **ERROR-11** may be displayed. Refer to the multi-CD player owner's manual.
- If there are no discs in the multi-CD player magazine, **NO DISC** is displayed.
- When you select a CD TEXT disc on a CD TEXT compatible multi-CD player, the disc and track titles begin to scroll to the left automatically. ■

50-disc multi-CD player

Only those functions described in this manual are supported for 50-disc multi-CD players. ■

Introduction of advanced multi-CD player operation

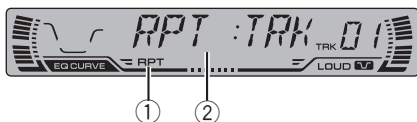

① RPT indicator

Shows when repeat range is selected to current track.

② Function display

Shows the function status.

● Press FUNCTION to display the function names.

Press **FUNCTION** repeatedly to switch between the following functions:

RPT (repeat play)—**RDM** (random play)
—**SCAN** (scan play)—**ITS-P** (ITS play)—**PAUSE** (pause)—**COMP** (compression and DBE)

- To return to the playback display, press **BAND**.



Note

If you do not operate the function within about 30 seconds, the display is automatically returned to the playback display. 

Repeating play

There are three repeat play ranges for the multi-CD player: **MCD** (multi-CD player repeat), **TRK** (one-track repeat) and **DSC** (disc repeat).

1 Press FUNCTION to select RPT.

Press **FUNCTION** until **RPT** appears in the display.

2 Press ◀ or ▶ to select the repeat range.

Press ◀ or ▶ until the desired repeat range appears in the display.

- **MCD** – Repeat all discs in the multi-CD player
- **TRK** – Repeat just the current track
- **DSC** – Repeat the current disc



Notes

- If you select other discs during repeat play, the repeat play range changes to **MCD**.
- If you perform track search or fast forward/reverse during **TRK**, the repeat play range changes to **DSC**. 

Playing tracks in a random order

Random play lets you play back tracks in a random order within the repeat range, **MCD** and **DSC**.

1 Select the repeat range.

Refer to *Repeating play* on this page.

2 Press FUNCTION to select RDM.

Press **FUNCTION** until **RDM** appears in the display.

3 Press ▲ to turn random play on.

RDM :ON appears in the display. Tracks will play in a random order within the previously selected **MCD** or **DSC** ranges.

4 Press ▼ to turn random play off.

RDM :OFF appears in the display. Tracks will continue to play in order.

Multi-CD Player

Note

If you turn random play on during **DSC** and then return to the playback display, **DRDM** appears in the display. 

Scanning CDs and tracks

While you are using **DSC**, the beginning of each track on the selected disc plays for about 10 seconds. When you are using **MCD**, the beginning of the first track of each disc is played for about 10 seconds.

1 Select the repeat range.

Refer to *Repeating play* on the previous page.

2 Press **FUNCTION** to select **SCAN**.

Press **FUNCTION** until **SCAN** appears in the display.

3 Press **▲** to turn scan play on.

SCAN :ON appears in the display. The first 10 seconds of each track of the current disc (or the first track of each disc) is played.

4 When you find the desired track (or disc) press **▼** to turn scan play off.

SCAN :OFF appears in the display. The track (or disc) will continue to play.

- If the display has automatically returned to the playback display, select **SCAN** again by pressing **FUNCTION**.

Notes

- After track or disc scanning is finished, normal playback of the tracks will begin again.
- If you turn scan play on during **DSC** and then return to the playback display, **DSCN** appears in the display. 

Pausing CD playback

Pause lets you temporarily stop playback of the CD.

1 Press **FUNCTION** to select **PAUSE**.

Press **FUNCTION** until **PAUSE** appears in the display.

2 Press **▲** to turn pause on.

PAUSE:ON appears in the display. Play of the current track pauses.

3 Press **▼** to turn pause off.

PAUSE:OFF appears in the display. Play will resume at the same point that you turned pause on.

Note

You can also turn pause on or off by pressing **PAUSE**. 

Using ITS playlists

ITS (instant track selection) lets you make a playlist of favorite tracks from those in the multi-CD player magazine. After you have added your favorite tracks to the playlist you can turn on ITS play and play just those selections.

Creating a playlist with ITS programming

You can use ITS to enter and playback up to 99 tracks per disc, up to 100 discs (with the disc title). (With multi-CD players sold before the CDX-P1250 and CDX-P650, up to 24 tracks can be stored in the playlist.)

1 Play a CD that you want to program.

Press **▲** or **▼** to select a CD.

2 Press FUNCTION and hold until TITLE IN appears in the display, then press FUNCTION to select ITS.

After **TITLE IN** is displayed, press **FUNCTION** repeatedly, the following functions appear in the display:

TITLE IN (disc title input)—**ITS** (ITS programming)

3 Select a desired track by pressing ◀ or ▶.

4 Press ▲ to store the currently playing track in the playlist.

IN is displayed briefly and the currently playing selection is added to your playlist. The display then shows **ITS** again.

5 Press BAND to return to the playback display.



Note

After data for 100 discs has been stored in memory, data for a new disc will overwrite the oldest one.

Playback from your ITS playlist

ITS play lets you listen to the tracks that you have entered into your ITS playlist. When you turn on ITS play, tracks from your ITS playlist in the multi-CD player will begin to play.

1 Select the repeat range.

Refer to *Repeating play* on page 26.

2 Press FUNCTION to select ITS-P.

Press **FUNCTION** until **ITS-P** appears in the display.

3 Press ▲ to turn ITS play on.

ITS-P:ON appears in the display. Playback begins of those tracks from your playlist within the previously selected **MCD** or **DSC** ranges.

▪ If no tracks in the current range are programmed for ITS play then **EMPTY** is displayed.

4 Press ▼ to turn ITS play off.

ITS-P:OFF appears in the display. Playback will continue in normal order from the currently playing track and CD.

Erasing a track from your ITS playlist

When you want to delete a track from your ITS playlist, you can if ITS play is on.

If ITS play is already on, skip to step 2. If ITS play is not already on, press **FUNCTION**.

1 Play a CD you want to delete a track from your ITS playlist, and turn ITS play on.

Refer to *Playback from your ITS playlist* on this page.

2 Press FUNCTION and hold until TITLE IN appears in the display, then press FUNCTION to select ITS.

After **TITLE IN** is displayed, press **FUNCTION** until **ITS** appears in the display.

3 Select a desired track by pressing ◀ or ▶.

4 Press ▼ to erase a track from your ITS playlist.

The currently playing selection is erased from your ITS playlist and playback of the next track from your ITS playlist begins.

▪ If there are no tracks from your playlist in the current range, **EMPTY** is displayed and normal play resumes.

5 Press BAND to return to the playback display.

Multi-CD Player

Erasing a CD from your ITS playlist

When you want to delete all tracks of a CD from your ITS playlist, you can if ITS play is off.

1 Play a CD that you want to delete.

Press ▲ or ▼ to select a CD.

2 Press FUNCTION and hold until TITLE IN appears in the display, then press FUNCTION to select ITS.

After TITLE IN is displayed, press FUNCTION until ITS appears in the display.

3 Press ▼ to erase all tracks on the currently playing CD from your ITS playlist.

All tracks on the currently playing CD are erased from your playlist and CLEAR is displayed.

4 Press BAND to return to the playback display.

Using disc title functions

You can input CD titles and display the title. Then you can easily search for and select a desired disc for play.

Entering disc titles

Disc title input lets you input CD titles up to 8 letters long and up to 100 disc titles (with ITS playlist) into the multi-CD player.

1 Play a CD that you want to enter the title.

Press ▲ or ▼ to select a CD.

2 Press FUNCTION and hold until TITLE IN appears in the display.

After TITLE IN is displayed, press FUNCTION repeatedly, the following functions appear in the display:

TITLE IN (disc title input)—**ITS** (ITS programming)

■ When playing a CD TEXT disc on a CD TEXT compatible multi-CD player, you cannot switch to **TITLE IN**. The disc title will have already been recorded on a CD TEXT disc.

3 Press ▲ or ▼ to select a letter of the alphabet.

Each press of ▲ will display a letter of the alphabet in **A B C ... X Y Z**, numbers and symbols in **1 2 3 ... > []** order. Each press of ▼ will display a letter in the reverse order, such as **Z Y X ... C B A** order.



4 Press ► to move the cursor to the next character position.

When the letter you want is displayed, press ► to move the cursor to the next position and then select the next letter. Press ◀ to move backwards in the display.

5 Move the cursor to the last position by pressing ► after entering the title.

When you press ► one more time, the entered title is stored in memory.

6 Press BAND to return to the playback display.



Notes

- Titles remain in memory, even after the disc has been removed from the magazine, and are recalled when the disc is reinserted.
- After data for 100 discs has been stored in memory, data for a new disc will overwrite the oldest one.

Displaying disc titles

You can display the title of any disc that has had a disc title entered.

- **Press DISPLAY.**

Press **DISPLAY** repeatedly to switch between the following settings:

Play time—**DISC TTL** (disc title)

When you select **DISC TTL**, the title of the currently playing disc is shown in the display.

- If no title has been entered for the currently playing disc, **NO TITLE** is displayed.

Using CD TEXT functions

You can use these functions only with a CD TEXT compatible multi-CD player.

Some discs have certain information encoded on the disc during manufacture. These discs may contain such information as the CD title, track title, artist's name and playback time and are called CD TEXT discs. Only these specially encoded CD TEXT discs support the functions listed below.

Displaying titles on CD TEXT discs

- **Press DISPLAY.**

Press **DISPLAY** repeatedly to switch between the following settings:

Play time—**DISC TTL** (disc title)—**ART NAME**

(disc artist name)—**TRK TTL** (track title)

—**ART NAME** (track artist name)

- If specific information has not been recorded on a CD TEXT disc, **NO XXXX** will be displayed (e.g., **NO D-TTL**).

Scrolling titles in the display

This unit can display the first 8 letters only of **DISC TTL**, **ART NAME**, **TRK TTL** and **ART NAME**. When the recorded information is

longer than 8 letters, you can scroll the text to the left so that the rest of the title can be seen.

- **Press DISPLAY and hold until the title begins to scroll to the left.**

The rest of the title will appear in the display.

Using compression and bass emphasis

You can use these functions only with a multi-CD player that supports them.

Using **COMP** (compression) and **DBE** (dynamic bass emphasis) functions let you adjust the sound playback quality of the multi-CD player. Each of the functions have a two-step adjustment. The **COMP** function balances the output of louder and softer sounds at higher volumes. **DBE** boosts bass levels to give playback a fuller sound. Listen to each of the effects as you select through them and use the one that best enhances the playback of the track or CD that you are listening to.

1 Press FUNCTION to select COMP.

Press **FUNCTION** until **COMP** appears in the display.

- If the multi-CD player does not support **COMP/DBE**, **NO COMP** is displayed when you attempt to select it.

2 Press ▲ or ▼ to select your favorite setting.

Press **▲** or **▼** repeatedly to switch between the following settings:

COMP OFF—COMP 1—COMP 2—

COMP OFF—DBE 1—DBE 2

Audio Adjustments

Introduction of audio adjustments

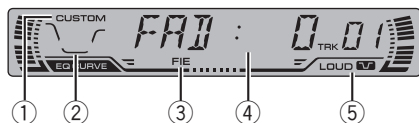

- ① **CUSTOM indicator**
Shows when custom equalizer curve is presently selected.
- ② **Equalizer curve**
Shows which equalizer preset is currently selected.
- ③ **FIE indicator**
Shows when the front image enhancer is turned on.
- ④ **Audio display**
Shows the audio adjustments status.
- ⑤ **LOUD indicator**
Appears in the display when loudness is turned on.

● Press AUDIO to display the audio function names.

Press **AUDIO** repeatedly to switch between the following audio functions:

FAD (balance adjustment)—**EQ-L** (equalizer)—**LOUD** (loudness)—**FIE** (front image enhancer)—**SLA** (source level adjustment)

- When selecting the FM tuner as the source, you cannot switch to **SLA**.
- To return to the display of each source, press **BAND**.

Note

If you do not operate the audio function within about 30 seconds, the display is automatically returned to the source display.

Using balance adjustment

You can select a fader/balance setting that provides an ideal listening environment in all occupied seats.

1 Press AUDIO to select FAD.

Press **AUDIO** until **FAD** appears in the display.

- If the balance setting has been previously adjusted, **BAL** will be displayed.

2 Press ▲ or ▼ to adjust front/rear speaker balance.

Each press of **▲** or **▼** moves the front/rear speaker balance towards the front or the rear.

FAD :F15 – FAD :R15 is displayed as the front/rear speaker balance moves from front to rear.

- **FAD : 0** is the proper setting when only two speakers are used.

3 Press ◀ or ▶ to adjust left/right speaker balance.

When you press **◀** or **▶**, **BAL 0** is displayed.

Each press of **◀** or **▶** moves the left/right speaker balance towards the left or the right.

BAL L9 – BAL R9 is displayed as the left/right speaker balance moves from left to right.

Using the equalizer

The equalizer lets you adjust the equalization to match car interior acoustic characteristics as desired.

Recalling equalizer curves

There are six stored equalizer curves which you can easily recall at any time. Here is a list of the equalizer curves:

Display	Equalizer curve
SPR-BASS	Super bass
POWERFUL	Powerful
NATURAL	Natural
VOCAL	Vocal
CUSTOM	Custom
EQ FLAT	Flat

- **CUSTOM** is an adjusted equalizer curve that you create.
- A separate **CUSTOM** curve can be created for each source. (The built-in CD player and the multi-CD player are set to the same equalizer adjustment setting automatically.) If you make adjustments, the equalizer curve settings will be memorized in **CUSTOM**.
- When **EQ FLAT** is selected no supplement or correction is made to the sound. This is useful to check the effect of the equalizer curves by switching alternatively between **EQ FLAT** and a set equalizer curve.

● Press EQ to select the equalizer.

Press **EQ** repeatedly to switch between the following equalizer:

SPR-BASS—POWERFUL—NATURAL—VOCAL—CUSTOM—EQ FLAT

Adjusting equalizer curves

You can adjust the currently selected equalizer curve setting as desired. Adjusted equalizer curve settings are memorized in **CUSTOM**.

1 Press AUDIO to select the equalizer curve adjustment.

Press **AUDIO** until **EQ-L** appears in the display.

- If the equalizer band has been previously adjusted, the band of that previously selected will be displayed instead of **EQ-L**.

2 Press ◀ or ▶ to select the equalizer band to adjust.

Each press of ◀ or ▶ selects equalizer bands in the following order:

EQ-L (low)—**EQ-M** (mid)—**EQ-H** (high)

3 Press ▲ or ▼ to adjust the level of the equalizer band.

Each press of ▲ or ▼ increases or decreases the level of the equalization band.

+6 – **–6** is displayed as the level is increased or decreased.

- You can then select another band and adjust the level.



Note

If you make adjustments when a curve other than **CUSTOM** is selected, the newly adjusted curve will replace the previous curve. Then a new curve with **CUSTOM** appears on the display while selecting the equalizer curve.

Fine adjusting equalizer curve

You can adjust the center frequency and the Q factor (curve characteristics) of each currently selected curve band (**EQ-L/EQ-M/EQ-H**).

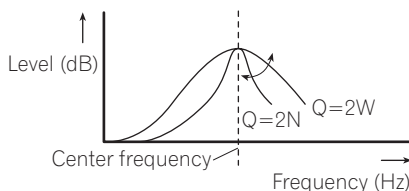

Audio Adjustments

1 Press AUDIO and hold until frequency and the Q factor (e.g., F- 80 Q 1W) appears in the display.

2 Press AUDIO to select the desired band for adjustment.

Low—Mid—High

3 Press ◀ or ▶ to select the desired frequency.

Press ◀ or ▶ until the desired frequency appears in the display.

Low: **40—80—100—160** (Hz)

Mid: **200—500—1k—2k** (Hz)

High: **3k—8k—10k—12k** (Hz)

4 Press ▲ or ▼ to select the desired Q factor.

Press ▲ or ▼ until the desired Q factor appears in the display.

2N—1N—1W—2W



Note

If you make adjustments when a curve other than **CUSTOM** is selected, the newly adjusted curve will replace the previous curve. Then a new curve with **CUSTOM** appears on the display while selecting the equalizer curve. 

Adjusting loudness

Loudness compensates for deficiencies in the low- and high-sound ranges at low volume.

1 Press AUDIO to select LOUD.

Press **AUDIO** until **LOUD** appears in the display.

2 Press ▲ to turn loudness on.

Loudness level (e.g., **LOUD MID**) appears in the display.

3 Press ◀ or ▶ to select a desired level.

Each press of ◀ or ▶ selects level in the following order:

LOW (low)—**MID** (mid)—**HI** (high)

4 Press ▼ to turn loudness off.

LOUD :OFF appears in the display.



Note

You can also turn loudness on or off by pressing **LOUDNESS**. 

Front image enhancer (F.I.E.)

The F.I.E. (Front Image Enhancer) function is a simple method of enhancing front imaging by cutting mid- and high-range frequency output from the rear speakers, limiting their output to low-range frequencies. You can select the frequency you want to cut.



Precaution

When the F.I.E. function is deactivated, the rear speakers output sound of all frequencies, not just bass sounds. Reduce the volume before disengaging F.I.E. to prevent a sudden increase in volume.

1 Press AUDIO to select FIE.

Press **AUDIO** until **FIE** appears in the display.

2 Press ▲ to turn F.I.E. on.

- To turn F.I.E. off, press ▼.

3 Press ◀ or ▶ to select a desired frequency.

Each press of ◀ or ▶ selects frequency in the following order:

100—160—250 (Hz)

**Notes**

- After turning the F.I.E. function on, use the balance adjustment (refer to page 31) and adjust front and rear speaker volume levels until they are balanced.
- Turn the F.I.E. function off when using a 2-speaker system. 

- External unit 1 and external unit 2 are set to the same source level adjustment volume automatically. 

Adjusting source levels

SLA (source level adjustment) lets you adjust the volume level of each source to prevent radical changes in volume when switching between sources.

- Settings are based on the volume level of the FM tuner, which remains unchanged.

1 Compare the FM tuner volume level with the level of the source you wish to adjust.

2 Press AUDIO to select SLA.

Press **AUDIO** until **SLA** appears in the display.

3 Press ▲ or ▼ to adjust the source volume.

Each press of **▲** or **▼** increases or decreases the source volume.

SLA: +4 – SLA: -4 is displayed as the source volume is increased or decreased.

**Notes**

- Since the FM tuner volume is the control, it is not possible to apply source level adjustments to the FM tuner.
- The AM tuner volume level can also be adjusted with source level adjustments.
- The built-in CD player and the multi-CD player are set to the same source level adjustment volume automatically.

Initial Settings

Adjusting initial settings

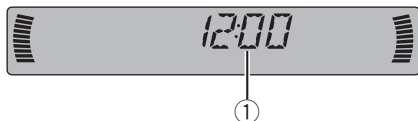

Initial settings lets you perform initial set up of different settings for this unit.

① Function display

Shows the function status.

1 Press SOURCE and hold until the unit turns off.

2 Press FUNCTION and hold until the clock appears in the display.

3 Press FUNCTION to select one of the initial settings.

Press **FUNCTION** repeatedly to switch between the following settings:

Clock—**WARN** (warning tone)—**AUX** (auxiliary input)

Use the following instructions to operate each particular setting.

- To cancel initial settings, press **BAND**.
- You can also cancel initial settings by holding down **FUNCTION** until the unit turns off.

Setting the clock

Use these instructions to set the clock.

1 Press FUNCTION to select clock.

Press **FUNCTION** repeatedly until clock appears in the display.

2 Press ◀ or ▶ to select the segment of the clock display you wish to set.

Pressing ◀ or ▶ will select one segment of the clock display:
Hour—Minute

As you select segments of the clock display the segment selected will blink.



3 Press ▲ or ▼ to set the clock.

Pressing ▲ will increase the selected hour or minute. Pressing ▼ will decrease the selected hour or minute.

Switching the warning tone

If the front panel is not detached from the head unit within five seconds of turning off the ignition, a warning tone will sound. You can turn off the warning tone.

1 Press FUNCTION to select WARN.

Press **FUNCTION** repeatedly until **WARN** appears in the display.

2 Press ▲ or ▼ to turn WARN on or off.

Pressing ▲ or ▼ will turn **WARN** on or off and that status will be displayed (e.g.,

WARN :ON).

Switching the auxiliary setting

It is possible to use auxiliary equipment with this unit. Activate the auxiliary setting when using auxiliary equipment connected to this unit.

1 Press FUNCTION to select AUX.

Press **FUNCTION** repeatedly until **AUX** appears in the display.

2 Press ▲ or ▼ to turn AUX on or off.

Pressing ▲ or ▼ will turn **AUX** on or off and that status will be displayed (e.g.,

AUX :ON).

Turning the clock display on or off

You can turn the clock display on or off.

- **Press CLOCK to turn the clock display on or off.**

Each press of **CLOCK** turns the clock display on or off.

- The clock display disappears temporarily when you perform other operations, but the clock display appears again after 25 seconds.



Note

Even when the sources are off, the clock display appears on the display. Pressing **CLOCK** turns the clock display on or off.

Using the AUX source

An IP-BUS-RCA Interconnector such as the CD-RB20/CD-RB10 (sold separately) lets you connect this unit to auxiliary equipment featuring RCA output. For more details, refer to the IP-BUS-RCA Interconnector owner's manual.

Selecting AUX as the source

- **Press SOURCE to select AUX as the source.**

Press **SOURCE** until **AUX** appears in the display.

- If the auxiliary setting is not turned on, **AUX** cannot be selected. For more details, see *Switching the auxiliary setting* on the previous page.

Setting the AUX title

The title displayed for the **AUX** source can be changed.

1 After you have selected AUX as the source, press FUNCTION and hold until TITLE IN appears in the display.

2 Press ▲ or ▼ to select a letter of the alphabet.

Each press of ▲ will display a letter of the alphabet in **A B C ... X Y Z**, numbers and symbols in **1 2 3 ... > []** order. Each press of ▼ will display a letter in the reverse order, such as **Z Y X ... C B A** order.



3 Press ► to move the cursor to the next character position.

When the letter you want is displayed, press ► to move the cursor to the next position and then select the next letter. Press ◀ to move backwards in the display.

4 Move the cursor to the last position by pressing ► after entering the title.

When you press ► one more time, the entered title is stored in memory.

5 Press BAND to return to the playback display.

Other Functions

Introduction of XM operation

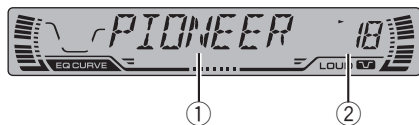

You can use this unit with a separately sold universal XM satellite digital tuner system (GEX-FM913XM) or XM satellite digital tuner (GEX-P910XM).

For details concerning operation, refer to the XM tuner's operation manuals. This section provides information on XM operations with this unit which differs from that described in the XM tuner's operation manual.

① XM tuner information

Shows the XM tuner information which has been selected.

② XM channel number indicator

Shows to which XM channel number the tuner is tuned.

- If a channel number 100 to 199 is selected, ► on the left of the XM channel number indicator will light.
- If a channel number 200 or more is selected, ► on the left of the XM channel number indicator will blink.

XM operation

XM operation of the following function with this unit differs.

- *Switching the XM channel select setting*
(Refer to this page.)

Switching the XM channel select setting

You can switch if you select a channel with a channel number or from a channel category when you select a channel.

1 Press PAUSE to select channel select setting.

2 Each press of PAUSE changes the channel select mode in the following order:
ch NUMBER (channel number select mode)
 —**CATEGORY** (channel category select mode)

Additional Information

Understanding built-in CD player error messages

When problems occur during CD play an error message may appear on the display. If an error message appears on the display refer to the table below to see what the problem is and the suggested method of correcting the problem. If the error cannot be corrected, contact your dealer or your nearest Pioneer Service Center.

Message	Cause	Action
ERROR-11, 12, 17, 30	Dirty disc	Clean disc.
ERROR-11, 12, 17, 30	Scratched disc	Replace disc.
ERROR-10, 11, 12, 17, 30, A0	Electrical or mechanical	Turn the ignition ON and OFF, or switch to a different source, then back to the CD player.
ERROR-22, 23	The CD format cannot be played back	Replace disc.
ERROR-44	All tracks are skip tracks	Replace disc.
HEAT	CD player overheated	Turn off the CD player until the CD player cools down.



CD player and care

- Use only CDs that have either of the two Compact Disc Digital Audio marks as shown below.



- Use only normal, round CDs. If you insert irregular, non-round, shaped CDs they may jam in the CD player or not play properly.



- Check all CDs for cracks, scratches or warped discs before playing. CDs that have cracks, scratches or are warped may not play properly. Do not use such discs.
- Avoid touching the recorded (non-printed side) surface when handling the disc.
- Store discs in their cases when not in use.
- Keep discs out of direct sunlight and do not expose the discs to high temperatures.
- Do not attach labels, write on or apply chemicals to the surface of the discs.
- To clean dirt from a CD, wipe the disc with a soft cloth outward from the center of the disc.



- If the heater is used in cold weather, moisture may form on components inside the CD player. Condensation may cause the CD player to not operate properly. If you think that condensation is a problem turn off the CD player for an hour or so to allow the CD player to dry out and wipe any damp discs with a soft cloth to remove the moisture.
- Road shocks may interrupt CD playback. ■

Additional Information

CD-R/CD-RW discs

- When CD-R/CD-RW discs are used, playback is possible only for discs which have been finalized.
- It may not be possible to play back CD-R/CD-RW discs recorded on a music CD recorder or a personal computer because of disc characteristics, scratches or dirt on the disc, or dirt, condensation, etc. on the lens of this unit.
- Playback of discs recorded on a personal computer may not be possible depending on the application settings and the environment. Please record with the correct format. (For details, contact the manufacturer of the application.)
- Playback of CD-R/CD-RW discs may become impossible in case of direct exposure to sunlight, high temperatures, or the storage conditions in the car.
- Titles and other text information recorded on a CD-R/CD-RW disc may not be displayed by this unit (in the case of audio data (CD-DA)).
- This unit conforms to the track skip function of the CD-R/CD-RW disc. The tracks containing the track skip information are skipped automatically (in case of audio data (CD-DA)).
- If you insert a CD-RW disc into this unit, time to playback will be longer than when you insert a conventional CD or CD-R disc.
- Read the precautions with CD-R/CD-RW discs before using them. 

MP3 files

- MP3 is short for MPEG Audio Layer 3 and refers to an audio compression technology standard.
- This unit allows playback of MP3 files on CD-ROM, CD-R and CD-RW discs. Disc re-

cordings compatible with level 1 and level 2 of ISO9660 and with the Romeo and Joliet file system can be played back.

- It is possible to play back multi-session compatible recorded discs.
- MP3 files are not compatible with packet write data transfer.
- The max. number of characters which can be displayed for a file name, including the extension (.mp3), is 32 characters from the first character.
- The max. number of characters which can be displayed for a folder name is 32 characters.
- In case of files recorded according to the Romeo and Joliet file system, only the first 32 characters can be displayed.
- When playing discs with MP3 files and audio data (CD-DA) such as CD-EXTRA and MIXED-MODE CDs, both types can be played only by switching mode between MP3 and CD-DA.
- The folder selection sequence for playback and other operations becomes the writing sequence used by the writing software. For this reason, the expected sequence at the time of playback may not coincide with the actual playback sequence. However, there also is some writing software which permits setting of the playback order.
- Files are compatible with the ID3 Tag Ver. 1.0 and Ver. 1.1 formats for display of album (disc title), track (track title) and artist (track artist).
- Only when MP3 files of 32, 44.1 and 48 kHz frequencies are played back, the emphasis function is valid. (16, 22.05, 24, 32, 44.1, 48 kHz sampling frequencies can be played back.)
- There is no m3u playlist compatibility.
- There is no compatibility with the MP3i (MP3 interactive) or mp3 PRO format.

Additional Information

- The sound quality of MP3 files generally becomes better with increasing bit rate. This unit can play recordings with bit rates from 8 kbps to 320 kbps, but in order to be able to enjoy a certain sound quality, it is recommended to use only discs recorded with a bit rate of at least 128 kbps.

Important

- When naming an MP3 file, add the corresponding filename extension (.mp3).
- This unit plays back files with the filename extension (.mp3) as an MP3 file. To prevent noise and malfunctions, do not use this extension for files other than MP3 files. 

About folders and MP3 files

- An outline of a CD-ROM with MP3 files on it is shown below. Subfolders are shown as folders in the folder currently selected.

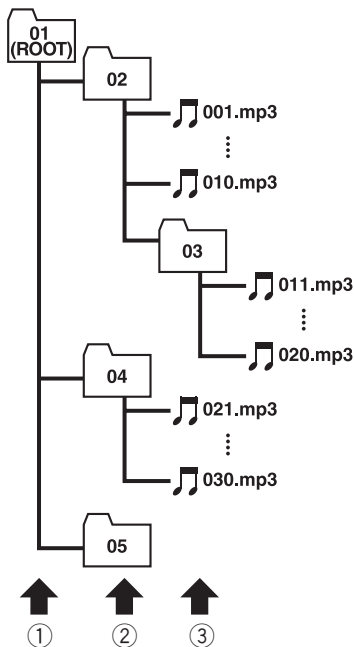

① **First level**

② **Second level**

③ **Third level**



Notes

- This unit assigns folder numbers. The user can not assign folder numbers.
- It is not possible to check folders that do not include MP3 files. (These folders will be skipped without displaying the folder number.)
- MP3 files in up to 8 tiers of folders can be played back. However, there is a delay in the start of playback on discs with numerous tiers. For this reason we recommend creating discs with no more than 2 tiers.
- It is possible to play back up to 253 items from folder on one disc. 

Additional Information

Terms

Bit rate

This expresses data volume per second, or bps units (bits per second). The higher the rate, the more information is available to reproduce the sound. Using the same encoding method (such as MP3), the higher the rate, the better the sound.

ID3 tag

This is a method of embedding track-related information in a MP3 file. This embedded information can include the track title, the artist's name, the album title, the music genre, the year of production, comments and other data. The contents can be freely edited using software with ID3 Tag editing functions. Although the tags are restricted to the number of characters, the information can be viewed when the track is played back.

ISO9660 format

This is the international standard for the format logic of CD-ROM folders and files. For the ISO9660 format, there are regulations for the following two levels.

Level 1:

The file name is in 8.3 format (the name consists of up to 8 characters, half-byte English capital letters and half-byte numerals and the “_” sign, with a file-extension of three characters.)

Level 2:

The file name can have up to 31 characters (including the separation mark “.” and a file extension). Each folder contains less than 8 hierarchies.

Extended formats

Joliet:

File names can have up to 64 characters.

Romeo:

File names can have up to 128 characters.

m3u

Playlists created using the “WINAMP” software have a playlist file extension (.m3u).

MP3

MP3 is short for MPEG Audio Layer 3. It is an audio compression standard set by a working group (MPEG) of the ISO (International Standards Organization). MP3 is able to compress audio data to about 1/10th the level of a conventional disc.

Multi-session

Multi-session is a recording method that allows additional data to be recorded later. When recording data on a CD-ROM, CD-R or CD-RW, etc., all data from beginning to end is treated as a single unit or session. Multi-session is a method of recording more than 2 sessions in one disc.

Packet write

This is a general term for a method of writing on CD-R, etc. at the time required for a file, just as is done with files on floppy or hard discs.

VBR

VBR is short for variable bit rate. Generally speaking CBR (constant bit rate) is more widely used. But to flexibly adjust the bit rate according to the needs of audio compression, it is possible to achieve compression priorities sound quality.

Additional Information

Specifications

General

Power source	14.4 V DC (10.8 – 15.1 V allowable)
Grounding system	Negative type
Max. current consumption	10.0 A
Dimensions (W × H × D):	
DIN	
Chassis	178 × 50 × 157 mm (7 × 2 × 6-1/8 in.)
Nose	188 × 58 × 19 mm (7-3/8 × 2-1/4 × 3/4 in.)
D	
Chassis	178 × 50 × 162 mm (7 × 2 × 6-3/8 in.)
Nose	170 × 46 × 14 mm (6-3/4 × 1-3/4 × 1/2 in.)
Weight	1.4 kg (3 lbs)

Audio

Continuous power output	is 22 W per channel minimum into 4 ohms, both channels driven 50 to 15,000 Hz with no more than 5% THD.
Maximum power output	50 W × 4
Load impedance	4 Ω (4 – 8 Ω allowable)
Preout max output level/output impedance	2.2 V/1 kΩ
Equalizer (3-Band Parametric Equalizer):	
Low	
Frequency	40/80/100/160 Hz
Q Factor	0.35/0.59/0.95/1.15 (+6 dB when boosted)
Gain	±12dB
Mid	
Frequency	200/500/1k/2k Hz
Q Factor	0.35/0.59/0.95/1.15 (+6 dB when boosted)
Gain	±12dB
High	
Frequency	3.15k/8k/10k/12.5k Hz
Q Factor	0.35/0.59/0.95/1.15 (+6 dB when boosted)
Gain	±12dB
Loudness contour	
Low	+3.5 dB (100 Hz), +3 dB (10 kHz)
Mid	+10 dB (100 Hz), +6.5 dB (10 kHz)

High	+11 dB (100 Hz), +11 dB (10 kHz) (volume: -30 dB)
------------	--

CD player

System	Compact disc audio system
Usable discs	Compact disc
Signal format:	
Sampling frequency	44.1 kHz
Number of quantization bits	16; linear
Frequency characteristics	5 – 20,000 Hz (±1 dB)
Signal-to-noise ratio	94 dB (1 kHz) (IHF-A network)
Dynamic range	92 dB (1 kHz)
Number of channels	2 (stereo)
MP3 decoding format	MPEG-1 & 2 Audio Layer 3

FM tuner

Frequency range	87.9 – 107.9 MHz
Usable sensitivity	8 dBf (0.7 μV/75 Ω mono, S/N: 30 dB)
50 dB quieting sensitivity	10 dBf (0.9 μV/75 Ω mono)
Signal-to-noise ratio	75 dB (IHF-A network)
Distortion	0.3 % (at 65 dBf, 1 kHz, stereo) 0.1 % (at 65 dBf, 1 kHz, mono)
Frequency response	30 – 15,000 Hz (±3 dB)
Stereo separation	45 dB (at 65 dBf, 1 kHz)
Selectivity	80 dB (±200 kHz)
Three-signal intermodulation (desired signal level)	30 dBf (two undesired signal level: 100 dBf)

AM tuner

Frequency range	530 – 1,710 kHz (10 kHz)
Usable sensitivity	18 μV (S/N: 20 dB)
Signal-to-noise ratio	65 dB (IHF-A network)



Note

Specifications and the design are subject to possible modifications without notice due to improvements. ▣

*Register your product at
Enregistrez votre produit au
Registre su producto en*

<http://www.pioneerelectronics.com>

*See "Product registration" page
Voir la page "Enregistrement du produit"
Consulte la página sobre "Registro del producto"*

PIONEER CORPORATION

4-1, MEGURO 1-CHOME, MEGURO-KU, TOKYO 153-8654, JAPAN

PIONEER ELECTRONICS (USA) INC.

P.O. Box 1540, Long Beach, California 90801-1540, U.S.A.
TEL: (800) 421-1404

PIONEER EUROPE NV

Haven 1087, Keetberglaan 1, B-9120 Melsele, Belgium
TEL: (0) 3/570.05.11

PIONEER ELECTRONICS ASIACENTRE PTE. LTD.

253 Alexandra Road, #04-01, Singapore 159936
TEL: 65-6472-1111

PIONEER ELECTRONICS AUSTRALIA PTY. LTD.

178-184 Boundary Road, Braeside, Victoria 3195, Australia
TEL: (03) 9586-6300

PIONEER ELECTRONICS OF CANADA, INC.

300 Allstate Parkway, Markham, Ontario L3R OP2, Canada
TEL: (905) 479-4411

PIONEER ELECTRONICS DE MEXICO, S.A. de C.V.

Bldv.Manuel Avila Camacho 138 10 piso
Col.Lomas de Chapultepec, Mexico, D.F. 11000
TEL: 55-9178-4270

Published by Pioneer Corporation.
Copyright © 2002 by Pioneer Corporation.
All rights reserved.

Publié par Pioneer Corporation. Copyright
© 2002 par Pioneer Corporation. Tous
droits réservés.

Printed in
Imprimé

Note:

Before installing this unit in your vehicle, refer to the illustration below and remove the tag.
Do not use the parts you have removed (screws etc.) when installing the unit in your vehicle.

Remarque:

Avant d'installer cet appareil dans votre voiture, reportez-vous à l'illustration ci-dessous et retirez cette cosse.
N'utilisez pas les pièces que vous avez retirées (vis, etc.) lors de l'installation de l'appareil dans votre voiture.

Nota:

Antes de instalar esta unidad en su vehículo, refiérase a la ilustración abajo y quite la pieza.
No utilice las partes retiradas (tornillos, etc.) al instalar la unidad en su vehículo.

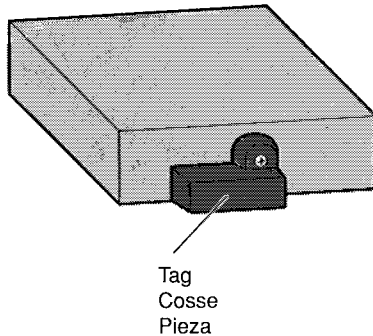

DEH-P4500MP

This product conforms to CEMA cord colors.
Le code de couleur des câbles utilisé pour ce produit est conforme à CEMA.
Los colores de los cables este producto se conforman con el código de colores CEMA.

Connecting the Units

Note:

- This unit is for vehicles with a 12-volt battery and negative grounding. Before installing it in a recreational vehicle, truck or bus, check the battery voltage.
- To avoid shorts in the electrical system, be sure to disconnect the ⊖ battery cable before beginning installation.
- Refer to the owner's manual for details on connecting the power amp and other units, then make connections correctly.
- Secure the wiring with cable clamps or adhesive tape. To protect the wiring, wrap adhesive tape around them where they lie against metal parts.
- Route and secure all wiring so it cannot touch any moving parts, such as the gear shift, handbrake and seat rails. Do not route wiring in places that get hot, such as near the heater outlet. If the insulation of the wiring melts or gets torn, there is a danger of the wiring short-circuiting to the vehicle body.
- Don't pass the yellow lead through a hole into the engine compartment to connect to the battery. This will damage the lead insulation and cause a very dangerous short.
- Do not shorten any leads. If you do, the protection circuit may fail to work when it should.
- Never feed power to other equipment by cutting the insulation of the power supply lead of the unit and tapping into the lead. The current capacity of the lead will be exceeded, causing overheating.
- When replacing fuse, be sure to use only fuse of the rating prescribed on this unit.
- Since a unique BPTL circuit is employed, never wire so the speaker leads are directly grounded or the left and right ⊖ speaker leads are common. If you ground the products together and the ground becomes detached, there is a risk of damage to the products or fire.
- The black lead is ground. Please ground this lead separately from the ground of high-current products such as power amps. If you ground the products together and the ground becomes detached, there is a risk of damage to the products or fire.
- Speakers connected to this unit must be high-power types with minimum rating of 50 W and impedance of 4 to 8 ohms. Connecting speakers with output and/or impedance values other than those noted here may result in the speakers catching fire, emitting smoke, or becoming damaged.

- When this product's source is switched ON, a control signal is output through the blue/white lead. Connect to an external power amp's system remote control or the car's Auto-antenna relay control terminal (max. 300 mA 12 V DC). If the car features a glass antenna, connect to the antenna booster power supply terminal.
- When an external power amp is being used with this system, be sure not to connect the blue/white lead to the amp's power terminal. Likewise, do not connect the blue/white lead to the power terminal of the auto-antenna. Such connection could cause excessive current drain and malfunction.
- To avoid short-circuiting, cover the disconnected lead with insulating tape. Especially, insulate the unused speaker leads without fail. There is a possibility of short-circuiting if the leads are not insulated.
- If this unit is installed in a vehicle that does not have an ACC (accessory) position on the ignition switch, the red lead of the unit should be connected to a terminal coupled with ignition switch ON/OFF operations. If this is not done, the vehicle battery may be drained when you are away from the vehicle for several hours. (Fig. 1)

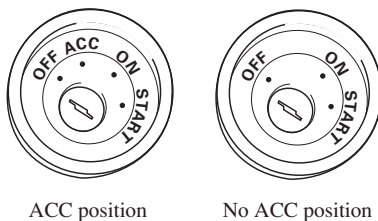

Fig. 1

- Cords for this product and those for other products may be different colors even if they have the same function. When connecting this product to another product, refer to the supplied Installation manuals of both products and connect cords that have the same function.

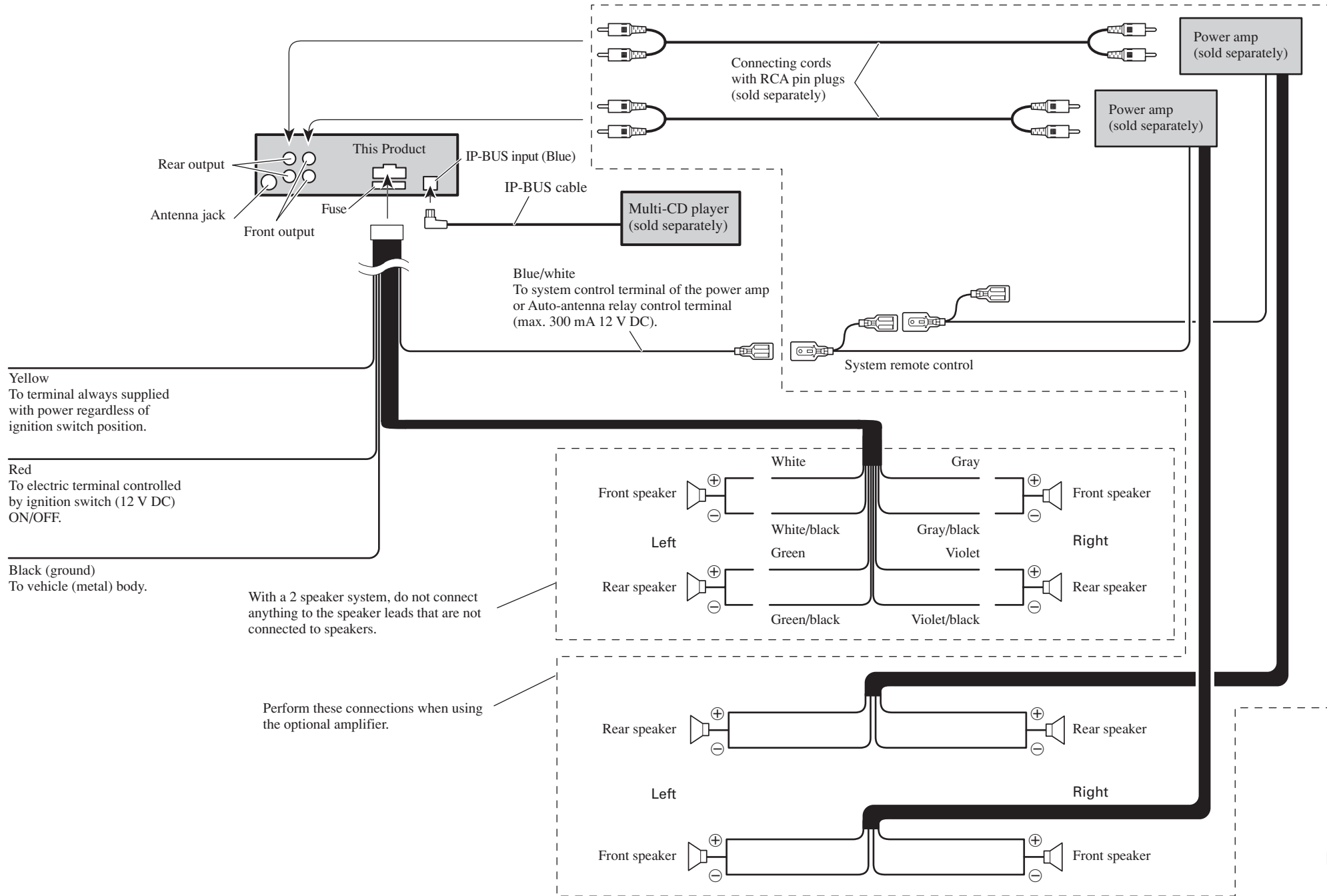

Fig. 2

Installation

Note:

- Before finally installing the unit, connect the wiring temporarily, making sure it is all connected up properly, and the unit and the system work properly.
- Use only the parts included with the unit to ensure proper installation. The use of unauthorized parts can cause malfunctions.
- Consult with your nearest dealer if installation requires the drilling of holes or other modifications of the vehicle.
- Install the unit where it does not get in the driver's way and cannot injure the passenger if there is a sudden stop, like an emergency stop.
- The semiconductor laser will be damaged if it overheats, so don't install the unit anywhere hot — for instance, near a heater outlet.

- If installation angle exceeds 60° from horizontal, the unit might not give its optimum performance. (Fig. 3)

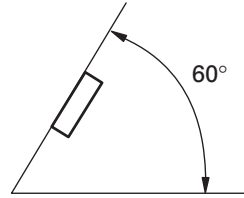

Fig. 3

DIN Front/Rear-mount

This unit can be properly installed either from “Front” (conventional DIN Front-mount) or “Rear” (DIN Rear-mount installation, utilizing threaded screw holes at the sides of unit chassis). For details, refer to the following illustrated installation methods.

DIN Front-mount

Installation with the rubber bush (Fig. 4)

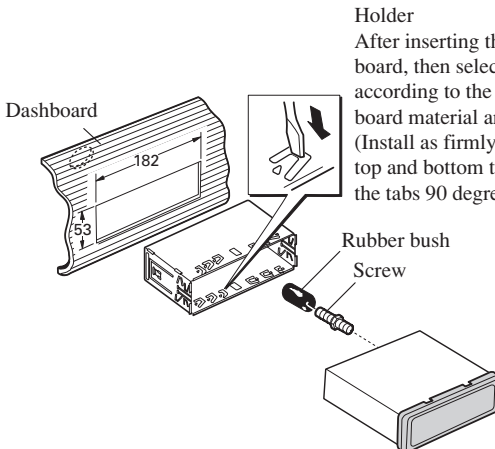

Holder
After inserting the holder into the dashboard, then select the appropriate tabs according to the thickness of the dashboard material and bend them. (Install as firmly as possible using the top and bottom tabs. To secure, bend the tabs 90 degrees.)

Fig. 4

Removing the Unit (Fig. 5) (Fig. 6)

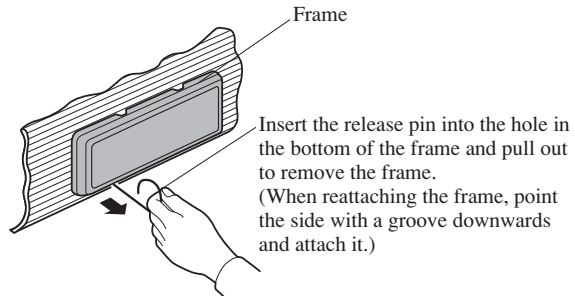

Fig. 5

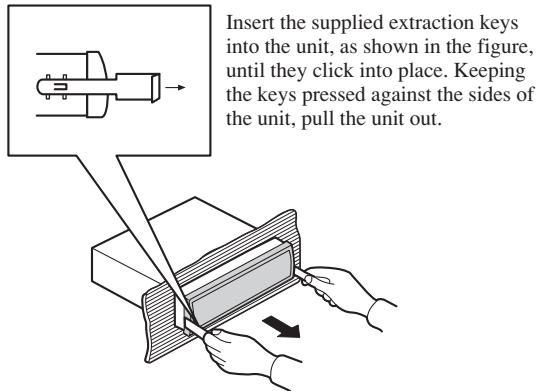

Fig. 6

DIN Rear-mount

Installation using the screw holes on the side of the unit

1. Remove the frame. (Fig. 7)

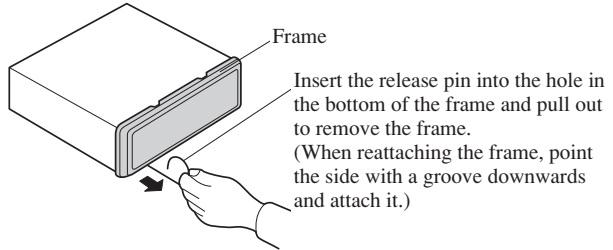

Fig. 7

2. Fastening the unit to the factory radio mounting bracket. (Fig. 8) (Fig. 9)

Select a position where the screw holes of the bracket and the screw holes of the head unit become aligned (are fitted), and tighten the screws at 2 places on each side. Use either truss screws (5×8 mm) or flush surface screws (5×9 mm), depending on the shape of the screw holes in the bracket.

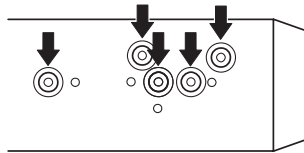

Fig. 8

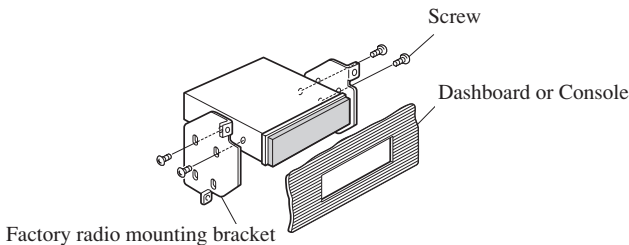

Fig. 9

Fixing the Front Panel

If you do not operate the Detaching and Replacing the Front Panel Function, use the supplied fixing screws and fix the front panel to this unit.

1. Attach the holders to both sides of the front panel. (Fig. 10)

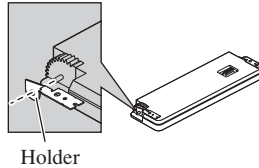

Fig. 10

2. Replace the front panel to the unit. (Fig. 11)

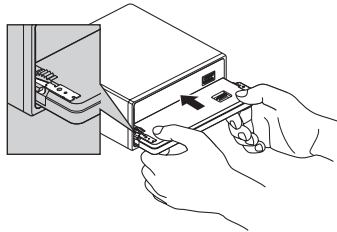

Fig. 11

3. Flip the holders into upright positions. (Fig. 12)

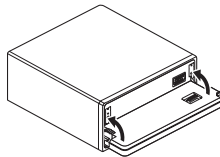

Fig. 12

4. Fix the front panel to the unit using fixing screws. (Fig. 13)

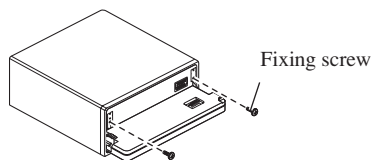

Fig. 13

*Please do not send products or other
correspondence to this address.*



First-Class
Postage
Required
Post Office will
not deliver
without proper
postage.

K T C 0 1 - 0 1

Single CD-3

Pioneer

PO BOX 174303

DENVER CO 80217-4303



Please fold here.

Pioneer

Return this card now for **FREE LOST & FOUND SERVICE**

- **Loss Protection.** If your Pioneer product is lost or stolen, BoomerangIt return service could help you get it back.
- **Easy Activation.** To activate your FREE 6-MONTH SERVICE, simply fill out and return this card. Then attach the enclosed BoomerangIt label to your Pioneer product. If your item is lost, whoever finds it can contact BoomerangIt using the instructions on the label. Then BoomerangIt uses the information you provide on this form to reach you and return your item.
- **Proof of Ownership.** Pioneer will keep the model #, serial # and date of purchase of your new Pioneer product on file to help you refer to this information in the event of an insurance claim such as loss or theft.

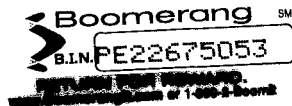

**For more information on other Pioneer products,
check out our website at www.pioneerelectronics.com**

Register your item.



Apply your BoomerangIt label.



Then if you lose it...



It can find you

Activate your FREE 6-month LOST & FOUND SERVICE today! Just fill out and return this product registration card to start your coverage.

Extend your BoomerangIt lost & found coverage and SAVE 50%.

- Continue Your Coverage.** Extend your free 6-month service for 10 years for just \$4.95 (a \$9.95 value).
- Protect More Items.** Get a Mobile Pack (5 labels, 2 key tags and 1 luggage tag) and protect more valuables. Ten-year coverage is just \$9.95 (a \$19.95 value).

BoomerangIt will send your label(s) and invoice to you. Go to www.BoomerangIt.com for more information.

BoomerangIt cannot guarantee the return of lost or stolen property. Subscribers must pay shipping & handling fees to facilitate return of items. Reward provided to finders of lost or stolen property is 8 free BoomerangIt registrations. Complete details of BoomerangIt Terms of Service are listed at www.BoomerangIt.com, or write us at 1776 Fairway Dr., San Leandro, CA 94577.



BoomerangIt works with the National Crime Prevention Council, local law enforcement agencies, and hospitality and transportation industry leaders to help return lost or stolen property to its rightful owner.

Pioneer PRODUCT REGISTRATION

All required fields (*) of this registration form must be completed before BoomerangIt service can be provided.

IMPORTANT!

*1. 1. Mr. 2. Mrs. 3. Ms. 4. Miss 5. Dr. Please complete and return within the next 10 days

First Name Initial Last Name **KTC01-01**

Street Apt. No.

City State ZIP Code

E-mail Address:

2. Your date of birth: / /
Month Year

3. Marital status: 1. Married 2. Single

*4. Telephone Number:
() -

*5. Date of purchase: / /
Month Day Year

*6. Model #: **DE** -
or **FH** - **P**

7. Serial #:

*8. BIN # (# on BoomerangIt label):

9. Where did you purchase your Pioneer Product?
Retailer Name:
1. Received as gift

10. In what vehicle will this Pioneer product be used?
(make: e.g. Ford, Nissan; Model: e.g. Taurus SHO, Maxima SE)
Make:
Model:
Year:
A. Bought New B. Bought Used C. Lease

11. Please rate the importance of the following features in your purchase decision:

	Not Important	Somewhat Important	Very Important
A. EEQ (Easy EQ)	1. <input type="checkbox"/>	2. <input type="checkbox"/>	3. <input type="checkbox"/>
B. Mosfet Power	1. <input type="checkbox"/>	2. <input type="checkbox"/>	3. <input type="checkbox"/>
C. Can Control			
Multi-Disc Changer	1. <input type="checkbox"/>	2. <input type="checkbox"/>	3. <input type="checkbox"/>
D. Multi-Color Display	1. <input type="checkbox"/>	2. <input type="checkbox"/>	3. <input type="checkbox"/>
E. Remote Control	1. <input type="checkbox"/>	2. <input type="checkbox"/>	3. <input type="checkbox"/>
F. Flap Face Design	1. <input type="checkbox"/>	2. <input type="checkbox"/>	3. <input type="checkbox"/>
G. Cosmetics	1. <input type="checkbox"/>	2. <input type="checkbox"/>	3. <input type="checkbox"/>

12. What three factors MOST influenced your purchase decision? (check only three)

1. <input type="checkbox"/> Brand Name/Reputation	6. <input type="checkbox"/> Warranty/Guarantee
2. <input type="checkbox"/> Price/Value	7. <input type="checkbox"/> Magazine Test Report
3. <input type="checkbox"/> Salesperson	8. <input type="checkbox"/> Cosmetics
4. <input type="checkbox"/> In-Store Demonstration	9. <input type="checkbox"/> Other
5. <input type="checkbox"/> Friend/Relative	

13. How did you first become aware of this Pioneer product?

01. <input type="checkbox"/> TV Ad	07. <input type="checkbox"/> Other Internet Source
02. <input type="checkbox"/> Radio Ad	08. <input type="checkbox"/> Salesperson
03. <input type="checkbox"/> Newspaper Ad	09. <input type="checkbox"/> Friend/Relative
04. <input type="checkbox"/> Stereo Magazine Ad	10. <input type="checkbox"/> Previous Experience
05. <input type="checkbox"/> Stereo Magazine Article	with Pioneer
06. <input type="checkbox"/> Pioneer Website	11. <input type="checkbox"/> Other

14. Which of the following magazines do you subscribe to or read frequently?

01. <input type="checkbox"/> Super Street	09. <input type="checkbox"/> Vibe
02. <input type="checkbox"/> Auto Sound & Security	10. <input type="checkbox"/> Maxim
03. <input type="checkbox"/> Car Sound	11. <input type="checkbox"/> ESPN The Magazine
04. <input type="checkbox"/> Sport Compact Car	12. <input type="checkbox"/> Motocross
05. <input type="checkbox"/> Mobile Entertainment	13. <input type="checkbox"/> FHM
06. <input type="checkbox"/> Rolling Stone	14. <input type="checkbox"/> Playboy
07. <input type="checkbox"/> Spin	15. <input type="checkbox"/> Dirt Rider
08. <input type="checkbox"/> The Source	16. <input type="checkbox"/> Other

15. Would you be willing to participate in future Pioneer surveys via e-mail?
1. Yes 2. No

16. Gender: 1. Male 2. Female

17. (Not including yourself, what is the GENDER and AGE (in years) of children and other adults living in your household?)

1. <input type="checkbox"/> No one else in household	2. <input type="checkbox"/> Child under 1 year
Male <input type="checkbox"/> Female <input type="checkbox"/> Age <input type="text"/> yrs.	Male <input type="checkbox"/> Female <input type="checkbox"/> Age <input type="text"/> yrs.
1. <input type="checkbox"/> 2. <input type="checkbox"/> <input type="text"/> yrs.	1. <input type="checkbox"/> 2. <input type="checkbox"/> <input type="text"/> yrs.

18. Occupation: (check all that apply)

	You	Spouse
Professional/Technical	<input type="checkbox"/> 1.	<input type="checkbox"/>
Upper Management/Executive	<input type="checkbox"/> 2.	<input type="checkbox"/>
Middle Management	<input type="checkbox"/> 3.	<input type="checkbox"/>
Sales/Marketing	<input type="checkbox"/> 4.	<input type="checkbox"/>
Clerical/Service Worker	<input type="checkbox"/> 5.	<input type="checkbox"/>
Tradesman/Machine Operator/Laborer ...	<input type="checkbox"/> 6.	<input type="checkbox"/>

19. Are you or your spouse:

	You	Spouse
A Homemaker?	<input type="checkbox"/> 1.	<input type="checkbox"/>
Retired?	<input type="checkbox"/> 2.	<input type="checkbox"/>
A Student?	<input type="checkbox"/> 3.	<input type="checkbox"/>
Self Employed/Business Owner?	<input type="checkbox"/> 4.	<input type="checkbox"/>
Working from a Home Office?	<input type="checkbox"/> 5.	<input type="checkbox"/>
In the Military?	<input type="checkbox"/> 6.	<input type="checkbox"/>
A Federal Employee?	<input type="checkbox"/> 7.	<input type="checkbox"/>

20. Which group describes your annual family income?

01. <input type="checkbox"/> Under \$15,000	08. <input type="checkbox"/> \$75,000-\$99,999
02. <input type="checkbox"/> \$15,000-\$19,999	09. <input type="checkbox"/> \$100,000-\$124,999
03. <input type="checkbox"/> \$20,000-\$29,999	10. <input type="checkbox"/> \$125,000-\$149,999
04. <input type="checkbox"/> \$30,000-\$39,999	11. <input type="checkbox"/> \$150,000-\$174,999
05. <input type="checkbox"/> \$40,000-\$49,999	12. <input type="checkbox"/> \$175,000-\$199,999
06. <input type="checkbox"/> \$50,000-\$59,999	13. <input type="checkbox"/> \$200,000-\$249,999
07. <input type="checkbox"/> \$60,000-\$74,999	14. <input type="checkbox"/> \$250,000 & over

21. Level of education: (check highest level completed)

1. <input type="checkbox"/> Completed High School
2. <input type="checkbox"/> Completed College
3. <input type="checkbox"/> Completed Graduate School

22. Which credit cards do you use regularly?

1. <input type="checkbox"/> American Express, Diners Club
2. <input type="checkbox"/> MasterCard, Visa, Discover
3. <input type="checkbox"/> Department Store, Oil Company, etc.
4. <input type="checkbox"/> Do not use credit cards

23. For your primary residence, do you: 1. Own? 2. Rent?

24. Please check all that apply to your household.

- | | | |
|---|--|---|
| 01. <input type="checkbox"/> Shop by Catalog/Mail | 06. <input type="checkbox"/> Have a Cat | 09. <input type="checkbox"/> Own an IBM or
Compatible Computer |
| 02. <input type="checkbox"/> Member of Frequent Flyer Program | 07. <input type="checkbox"/> Own a Cellular Phone | 10. <input type="checkbox"/> Own an Apple/Macintosh Computer |
| 03. <input type="checkbox"/> Donate to Charitable Causes | 08. <input type="checkbox"/> Subscribe to an Online/
Internet Service | 11. <input type="checkbox"/> Own a CD-ROM |
| 04. <input type="checkbox"/> Own a Compact Disc Player | | |
| 05. <input type="checkbox"/> Have a Dog | | |

25. To help us understand our customers' lifestyles, please indicate the interests and activities in which you or your spouse enjoy participating on a regular basis.

- | | | | |
|---|---|---|--|
| 01. <input type="checkbox"/> Bicycling | 15. <input type="checkbox"/> Flower Gardening | 28. <input type="checkbox"/> Photography | 41. <input type="checkbox"/> Stocks/Bonds/
Mutual Funds |
| 02. <input type="checkbox"/> Golf | 16. <input type="checkbox"/> Vegetable Gardening | 29. <input type="checkbox"/> Attending Cultural/
Arts Events | 42. <input type="checkbox"/> Entering Sweepstakes |
| 03. <input type="checkbox"/> Physical Fitness/Exercise | 17. <input type="checkbox"/> Crafts | 30. <input type="checkbox"/> Fashion Clothing | 43. <input type="checkbox"/> Casino Gambling |
| 04. <input type="checkbox"/> Running/Jogging | 18. <input type="checkbox"/> Buy Prerecorded Videos | 31. <input type="checkbox"/> Fine Art/Antiques | 44. <input type="checkbox"/> Science Fiction |
| 05. <input type="checkbox"/> Snow Skiing | 19. <input type="checkbox"/> Automotive Work | 32. <input type="checkbox"/> Foreign Travel | 45. <input type="checkbox"/> Wildlife/
Environmental Issues |
| 06. <input type="checkbox"/> Tennis | 20. <input type="checkbox"/> Electronics | 33. <input type="checkbox"/> Cruise Ship Vacations | 46. <input type="checkbox"/> Dieting/Weight Control |
| 07. <input type="checkbox"/> Camping/Hiking | 21. <input type="checkbox"/> Home Workshop/
Do-It-Yourself | 34. <input type="checkbox"/> Travel in USA | 47. <input type="checkbox"/> Science/
New Technology |
| 08. <input type="checkbox"/> Fishing | 22. <input type="checkbox"/> Recreation Vehicles | 35. <input type="checkbox"/> Gourmet Cooking/
Fine Foods | 48. <input type="checkbox"/> Self-Improvement |
| 09. <input type="checkbox"/> Hunting/Shooting | 23. <input type="checkbox"/> Listen to Records/
Tapes/CDs | 36. <input type="checkbox"/> Wines | 49. <input type="checkbox"/> Walking for Health |
| 10. <input type="checkbox"/> Horseback Riding | 24. <input type="checkbox"/> Surf the Internet | 37. <input type="checkbox"/> Coin/Stamp Collecting | 50. <input type="checkbox"/> Watching Sports on TV |
| 11. <input type="checkbox"/> Powerboating | 25. <input type="checkbox"/> Avid Book Reading | 38. <input type="checkbox"/> Collectibles/Collections | 51. <input type="checkbox"/> Home Video Recording |
| 12. <input type="checkbox"/> Sailing | 26. <input type="checkbox"/> Bible/Devotional Reading | 39. <input type="checkbox"/> Our Nation's Heritage | 52. <input type="checkbox"/> Moneymaking
Opportunities |
| 13. <input type="checkbox"/> Grandchildren | 27. <input type="checkbox"/> Health/Natural Foods | 40. <input type="checkbox"/> Real Estate Investments | |
| 14. <input type="checkbox"/> Needlework/Knitting/
Sewing | | | |

26. Using the numbers in the above list, please indicate your 3 most important activities:

Thanks for taking the time to fill out this questionnaire. Your answers will be used for market research studies and reports. They will also allow you to receive important mailings and special offers from a number of fine companies whose products and services relate directly to the specific interests, hobbies, and other information indicated above. Through this selective program, you will be able to obtain more information about activities in which you are involved and less about those in which you are not. Please check here if, for some reason, you would prefer *not* to participate in this opportunity.

Please check here if you do not want to receive mailings and offers using your E-mail address.



PIONEER ELECTRONICS (USA) INC. - PIONEER ELECTRONICS OF CANADA, INC.
(PA) (POC)

LIMITED WARRANTY

WARRANTY VALID ONLY IN COUNTRY OF PRODUCT PURCHASE

WARRANTY PERIOD

For the period specified below from date of original retail purchase (the warranty period) from an authorized Pioneer dealer, Pioneer Electronics (USA) Inc. (PA), and Pioneer Electronics Of Canada, Inc. (POC), warrant that products distributed by PA in the U.S.A., and by POC in Canada that fail to function properly under normal use due to a manufacturing defect when installed and operated according to the owner's manual enclosed with the unit will be repaired or replaced with a unit of comparable value, at the option of PA or POC, without charge to you for parts or actual repair work. Parts supplied under this warranty may be new or rebuilt at the option of PA or POC.

The warranty period for retail customers who rent the product commences upon the date product is first put into use (a) during the rental period or (b) retail sale, whichever occurs first.

The warranty does not cover any product which is used in any trade or business, or in an industrial or commercial application.

**WARRANTY PERIOD
PARTS LABOR**

PRODUCT

Car Stereo ProductsONE YEAR ONE YEAR

This warranty covers the product during the warranty period whether in the possession of the original owner or any subsequent owner. In the event service is required, the product must be delivered within the warranty period, transportation prepaid, from within the country of purchase as explained in this document. You will be responsible for removal and installation of the product. PA or POC, as appropriate, will pay for the cost of returning the repaired or replacement product to you within the country of purchase.

WHAT'S NOT COVERED

This warranty does not apply to any speaker that has been subjected to power in excess of its published power rating.

This warranty does not cover the cabinet or any appearance item, user attached antennas, any damage to recordings or recording tapes or discs, any damage to the product resulting from alterations, modifications not authorized in writing by PA or POC, accident, misuse or abuse, damage due to lightning or to power surges, subsequent damage from leaking, damaged or inoperative batteries or the use of batteries not conforming to those specified in the owner's manual.

This warranty does not cover the cost of parts or labor which would be otherwise provided without charge under this warranty, obtained from any source other than a PA or POC Authorized Service Company or other designated location. This warranty does not cover defects or damage caused by the use of unauthorized parts or labor, or from improper maintenance.

ALTERED, DEFACED OR REMOVED SERIAL NUMBERS VOID THIS WARRANTY.

YOUR RIGHTS

PA and POC exclude any obligation on their part for incidental or consequential damages related to the failure of products each distributes to function properly under the conditions set forth above.

IN THE U.S.A. - PA LIMITS ITS OBLIGATIONS UNDER ANY IMPLIED WARRANTIES INCLUDING, BUT NOT LIMITED TO, THE IMPLIED WARRANTIES OF MERCHANTABILITY AND FITNESS FOR A PARTICULAR PURPOSE TO A PERIOD NOT TO EXCEED THE WARRANTY PERIOD. NO WARRANTIES SHALL APPLY AFTER THE WARRANTY PERIOD. SOME STATES DO NOT ALLOW LIMITATIONS ON HOW LONG AN IMPLIED WARRANTY LASTS, AND SOME STATES DO NOT ALLOW THE EXCLUSION OR LIMITATION OF INCIDENTAL OR CONSEQUENTIAL DAMAGES, SO THE ABOVE LIMITATIONS OR EXCLUSIONS MAY NOT APPLY TO YOU. THIS WARRANTY GIVES YOU SPECIFIC LEGAL RIGHTS, AND YOU MAY HAVE OTHER RIGHTS WHICH MAY VARY FROM STATE TO STATE.

IN CANADA - EXCEPT AS EXPRESSLY PROVIDED HEREIN, THERE ARE NO REPRESENTATIONS, WARRANTIES, OBLIGATIONS OR CONDITIONS, IMPLIED, STATUTORY OR OTHERWISE, APPLICABLE TO THIS PRODUCT.

TO OBTAIN SERVICE

CAR STEREO PRODUCTS (EXCEPT CAR SPEAKERS SOLD IN THE U.S.A. ONLY)

PA and POC have appointed a number of Authorized Service Companies throughout the U.S.A. and Canada should your product ever require service. To receive warranty service you will need to present your sales receipt or, if rented, your rental contract showing place and date of original owner's transaction.

Should it become necessary to ship the unit you will need to package the product carefully and send it, transportation prepaid by a traceable, pre-insured method, to an Authorized Service Company. Carefully package the product using adequate padding material to prevent damage in transit. The original container is ideal for this purpose. Include in the package your name, address, telephone number where you can be reached during business hours, a copy of your sales receipt and a detailed description of the problem.

TO OBTAIN SERVICE

CAR SPEAKERS SOLD IN THE U.S.A. ONLY

Should your car speaker require service, return defective car speaker to your retail dealer for exchange. To receive warranty service you will need to present your sales receipt showing place and date of original owner's retail purchase. If, for any reason, you cannot exchange the speakers at the selling dealer, call the Customer Service Department as given below.

- ADDITIONAL INFORMATION -

IN THE U.S.A.

For additional information on this warranty, please call or write:

CUSTOMER SERVICE DEPARTMENT
PIONEER ELECTRONICS SERVICE, INC.
P.O. BOX 1760
LONG BEACH, CALIFORNIA 90801
1-800-421-1404

IN THE U.S.A. DO NOT RETURN ANY PRODUCT TO THE ABOVE ADDRESS. IT IS NOT A SERVICE LOCATION.

INCANADA

Please contact a Pioneer authorized Dealer to find the nearest Pioneer authorized service location. For additional information on this warranty, please call or write:

CUSTOMER SERVICE DEPARTMENT
PIONEER ELECTRONICS OF CANADA, INC.
300 ALLSTATE PARKWAY
MARKHAM, ON L3R 0P2
(905) 479-4411

IN THE U.S.A.

RECORD THE PLACE AND DATE OF PURCHASE FOR FUTURE REFERENCE

**FOR PRODUCT INFORMATION, TO PURCHASE REPLACEMENT PARTS OR TO LOCATE AN AUTHORIZED SERVICE COMPANY
CALL: 1-800-421-1404**

Model No. _____ Serial No. _____ Purchase Date _____

Purchased From _____

KEEP THIS INFORMATION AND YOUR SALES RECEIPT IN A SAFE PLACE