

LOWRANCE®

www.lowrance.com



LHR-80

Handheld Marine GPS VHF Radio

Installation and Operation Instructions

Pub. 988-0158-101

Lowrance® is a registered trademark of Navico

No part of this manual may be copied, reproduced, republished, transmitted or distributed for any purpose, without prior written consent of Lowrance Electronics.





Any unauthorized commercial distribution of this manual is strictly prohibited.

Lowrance Electronics may find it necessary to change or end policies, regulations, and special offers at any time. We reserve the right to do so without warning. All features and specifications are also subject to change without warning. All screens in this manual are simulated. LHR-80 VHF shown on cover. Other models covered in the manual are similar.

In accordance with EU regulations, DSC is not available in Europe.

For free owner's manuals and the most current information on this product, its operation and accessories, visit our web site: www.lowrance.com

Lowrance Electronics
12000 E. Skelly Dr.
Tulsa, OK USA 74128-2486
Printed in China.

Important safety information Please read carefully before installation and use.	
	This is the safety alert symbol. It is used to alert you to potentially hazardous situations. Obey all safety messages that follow this symbol to avoid possible injury or death.
	WARNING indicates a potentially hazardous situation which, if not avoided, could result in death or serious injury
	CAUTION indicates a potentially hazardous situation which, if not avoided, could result in minor or moderate injury.
	CAUTION used without the safety alert symbol indicates a potentially hazardous situation which, if not avoided, may result in property damage.

Contents

Safety and Operational Information	6
Section 1 - General Information	8
Section 2 - Controls and Keys	9
2-1 Keys/Controls & Functions.....	10
Section 3 - VHF Radio Operation	13
3-1 Batteries and Charger	13
3-1-1 Installing the Battery Pack	13
3-1-2 Initial Charge	13
3-1-3 GPS Connector	14
3-1-4 Mounting Battery Charger to flat surface	15
3-1-5 Mounting Battery Charger and bracket onto wall	15
3-2 Installing the Belt Clip	16
3-3 Installing and Removing the Antenna	17
3-4 Power On/Off.....	18
3-5 Adjusting the Squelch level	18
3-6 Volume control.....	18
3-7 Channel selection	19
3-8 Receiving and transmitting.....	19
3-9 Dual Watch Operation	20
3-10 3CH Operation (Favorite Channel)	20
3-10-1 Add a favorite channel for the first time	20
3-10-2 Modify or Delete favorite channel.....	20
3-11 Scan Operation.....	21
3-12 Navigation Mode	21
3-13 WP Select Mode	22
3-14 Plotter Mode	22
3-15 GPS Satellite Mode.....	23
Section 4 - Advanced Operation	24
4-1 Buddy List (Manage your buddy list. US only).....	26
4-1-1 Add a new buddy name.....	26
4-1-2 Edit a buddy name.....	27
4-1-3 DELETE a buddy name	27
4-2 Waypoint	28
4-2-1 Add a new waypoint.....	28

4-2-2 Edit a waypoint.....	29
4-2-3 Delete a waypoint.....	30
4-2-4 Set a route to a stored waypoint.....	30
4-3 Backlight Adjustment.....	31
4-4 Lamp Adjustment.....	31
4-5 Contrast Adjustment.....	31
4-6 GPS/DATA.....	32
4-6-1 Manual (Manually Enter Your Position and UTC Time).....	32
4-6-2 Settings: LL Display (Show or hide your position).....	33
4-6-3 Settings: Time Display (Show or hide the time).....	33
4-6-4 Time Offset (Local time).....	34
4-6-5 Settings: Time Format (12 or 24 hour clock).....	35
4-6-6 Settings: COG/SOG (Course & speed display options).....	36
4-6-7 GPS Alert.....	36
4-6-8 Turn GPS ENABLE on/off.....	37
4-6-9 Set True or Magnetic Bearing.....	37
4-7 Radio Setup.....	38
4-7-1 UIC (US only).....	38
4-7-2 Channel Name Editing.....	38
4-7-3 Ring Volume Adjustment.....	39
4-7-4 Beep Volume Adjustment.....	39
4-7-5 Select Unit (UNITS).....	39
4-7-6 Set the Priority Channel (WATCH MODE) US Only.....	40
4-7-7 WX Alert (Weather alerts).....	40
4-7-8 Set NMEA OUT (NMEA OUT).....	40
4-8 DSC Setup (US only).....	41
4-8-1 Enter or check your USER MMSI.....	41
4-8-2 Maintain Groups.....	42
4-8-2-1 Enter your Groups.....	42
4-8-2-2 Edit user Groups.....	43
4-8-2-3 Delete a Group.....	43
4-8-3 Response to Individual Calls.....	44
4-8-4 DSC Select.....	44
4-8-5 LL Reply.....	44
4-9 ATIS SETUP (EU only).....	45
4-9-1 Enter or Check your ATIS MMSI.....	45
4-9-2 ATIS Select.....	46
4-10 Get Buddy.....	46
4-11 Track Log.....	47
4-12 Erase Track.....	47
4-13 Reset (Reset to factory defaults).....	47

Section 5 - Sending and Receiving DSC Calls (US only)48

5-1 What is DSC?	48
5-1-1 Maritime Mobile Service Identity	48
5-1-2 How can I obtain a MMSI assignment?	48
5-2 DSC Call Types	49
5-2-1 Send an Individual call	50
5-3 Send a Group Call.....	51
5-4 Send an All Ships call	51
5-5 Reply to a call in your Call Log.....	52
5-6 Reply to a call in your Distress Log	53
5-7 Reply to the Last Call.....	54
5-8 Request the LL position of a buddy (LL Request).....	55
5-9 Track Your Buddy (Track Buddy)	55
5-9-1 Add or Delete a Buddy (Buddy List)	55
5-9-2 Select your want track's buddy	56
5-9-3 Set the time interval of tracking	56
5-9-4 Start Tracking	56
5-10 Receive an All Ships call	57
5-11 Receive a Group call	57
5-12 Reply to an LL position request.....	58
5-12-1 Manually reply to an LL Request.....	58
5-12-2 Automatically reply to an LL position request	58
5-12-3 Do not reply to an LL position request	59
5-13 Receive an individual call.....	59
5-14 Receive a Polled Position Call.....	59

Section 6 - Distress Calls (US only)60

6-1 Send a Distress Call.....	60
6-2 Receive a Distress Call	61
6-3 Receive a Distress Relay Call.....	61
6-4 Receive Distress Acknowledgement (DISTRESS ACK).....	62
6-5 Relay a Distress Call from the Distress LOG (RELAY)	62

Appendix A - Technical Specifications.....64

A-1 General:.....	64
A-2 Receiver:	64
A-3 Transmitter:	65
A-4 GPS and Navigation:.....	65

Appendix B - Frequency Charts	66
International Marine Channels	66
Special Notes on International Channel Usage.....	67
USA Channel Chart	68
Special Notes on USA Channel Usage	69
CANADA Channel Chart	70
Special Notes on Canada Channel Usage.....	71
WEATHER Channels.....	72
Appendix C - EU Inland Waterway Channels	73
Special Channels ²	76
Navico Full Two-Year Lowrance VHF Warranty	77
How to Obtain Service	78
In the USA.....	78
In Canada.....	78
Outside Canada and the USA.....	78
Accessory Ordering Information for all countries.....	79
Shipping Information	79

Safety and Operational Information

CAUTION

Due to European Union (EU) regulations, DSC is not available in the LHR-80E (EU) model.

WARNING

Never leave your radio in a closed car or trunk; the extremely high temperatures generated in hot weather can damage the electronics.

FCC Statement

This device complies with part 15 of the FCC Rules. Operation is subject to the following two conditions: (1) This device may not cause harmful interference, and (2) this device must accept any interference received, including interference that may cause undesired operation.

FCC regulations require that members of the general public should not be exposed to excessive levels of radio frequency radiation. To comply with the specified limits it is recommended that this radio is operated in such a manner as to limit transmission to no more than five minutes in any half hour period and that the antenna is kept at least 8 inches from any part of the body during transmission.

CAUTION: Changes or modifications not expressly approved by the manufacturer could void the user's authority to operate the equipment.

IMPORTANT

1. DSC functions will not operate until you have entered your user MMSI.
2. The radio channels installed into the radio may vary from country to country, depending upon the model and government or national communications authority regulations.
3. Lowrance recommends that you check the radio operating licensing requirements of your country before using the radio. The operator is solely responsible for observing proper radio installation and usage practices.
4. This radio is designed to generate a digital maritime distress call to facilitate search and rescue. To be effective as a safety device, this radio must be used only within the geographic range of a shore-based VHF marine Channel 70 distress and safety watch system. The geographic range may vary but under normal conditions is approximately 20 nautical miles.

It is the owner's sole responsibility to install and use the instrument in such a manner that will not cause accidents, personal injury or property damage.

Lowrance disclaims all liability for any use of this product in a way that may cause accidents, damage or that may violate the law.

Governing Language: This statement, any instruction manuals, user guides and other information relating to the product (Documentation) may be translated to, or has been translated from, another language (Translation). In the event of any conflict between any Translation of Documentation, the English language version of the Documentation will be the official version of the Documentation.

This manual represents the LHR-80 radio at the time of printing. Lowrance reserves the right to make changes to specifications without notice.

Section 1 - General Information

Congratulations on your purchase of this handheld VHF marine radio LHR-80, designed and built using superior technology and craftsmanship. It provides the following useful features:

- Adjustable contrast settings for the LCD
- Adjustable keypad backlighting for easy night time use
- Waterproof and submersible to comply with JIS-7
- GPS latitude and longitude (LL) and time display
- Built-in GPS sensor
- Choice of High or Low (5W or 1W) transmission power
- Special CH16 key for quick access to the priority (international distress) channel
- Special 3CH key to select your three favorite channels
- Flexible dual watch facility
- DSC (Digital Selective Calling) capability that meets USCG SC101 Standards (US only)
DISTRESS call button to automatically transmit the MMSI and position until and acknowledgement is received (US only)
- Easy access to a buddy list of up to 20 favorite people (US only)
- LL position polling information
- Buddy tracking capacity
- Weather alert facility (US only)
- ATIS facility for inland waterways (Europe only)

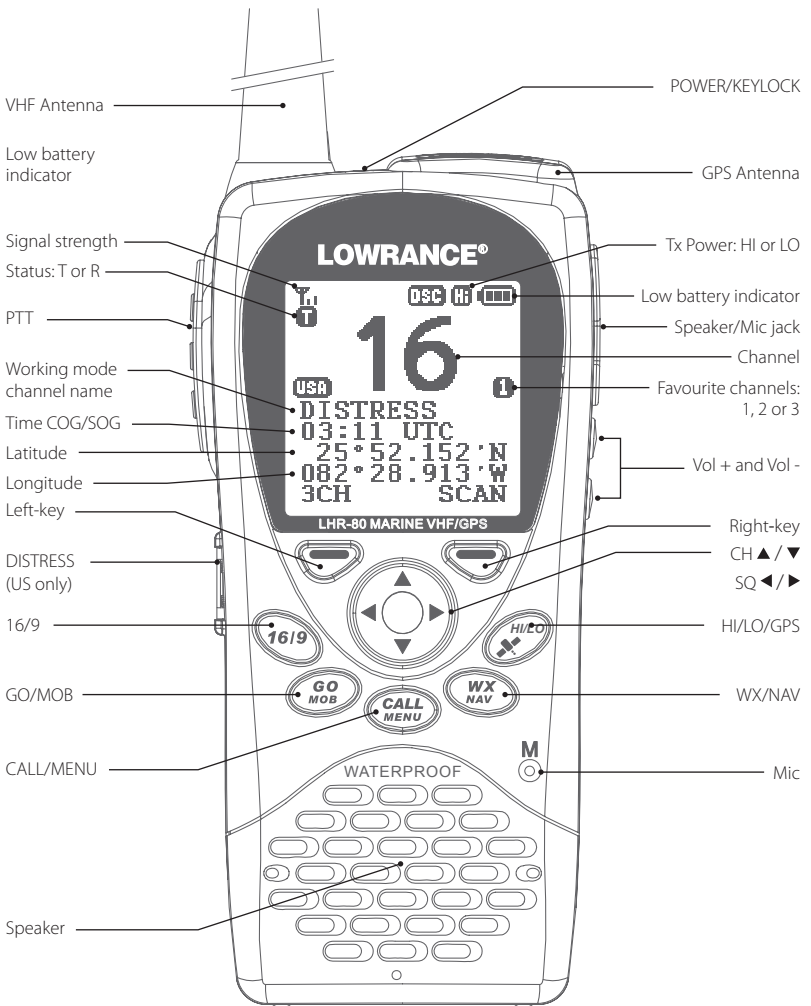

Section 2 - Controls and Keys



2-1 Keys/Controls & Functions

PWR On/Off & KEYLOCK

To turn the unit on and off, press and hold down PWR /  (red key) for more than 2 seconds and release.

The keylock, locks and unlocks keypad. Press PWR /  (red key) for 1 second and release. A key icon  will appear on screen to indicate whether keylock is on or off.

VOL ▲ / ▼

Volume Adjustment. Press to increase or decrease until a comfortable volume is reached.

SQL ◀ / ▶



Squelch or Threshold Level. Sets the threshold level for the minimum receiver signal. 16 steps available.

16/9

Priority Channel. Press to cancel all other modes and to tune into the priority channel. Press again to return to your original channel. To make Channel 09 the default instead, hold down 16/9 until a beep sounds and 09 is displayed (US only).

16 Priority Channel. Press to cancel all other modes and to turn into the priority channel. Press again to return to your original channel (EU only).

3CH/ ESC Left-key

Three Favorites Channels. Press to toggle between your favorite channels. The , , or  symbol appears on the LCD to show which favorite channel is selected.

If you want to scan all three favorite channels, press 3CH, then immediately press and hold SCAN.

To add a favorite channel for the first time, select that channel then hold 3CH to store it in the CH1 location. Repeat the procedure to store two more favorite channels in the CH2 and CH3 locations respectively.

If you try and add another favorite channel it will overwrite the existing CH3. CH1 and CH2 will remain unless you delete them.

To delete a favorite channel, select that channel then hold down 3CH until a dialogue box appears to prompt the deletion.

Escape. Use ESC when navigating menus to clear incorrect entries, to exit from a menu without saving changes and to back up to the previous screen.

SCAN/ ENTER right-key

Scan. Quickly press and release for Dual Watch - scan between your current channel and the priority channel in DUAL mode.

Press and hold down SCAN for more than 2 seconds to enter ALL SCAN mode where the priority channel is checked every 1.5 seconds.

When a signal is received, scanning stops at that channel and "R" appears on the screen. If the signal ceases for more than 5 seconds, the scan restarts.

In ALL SCAN mode, when a signal is received, holding down left-key for more than 2 seconds makes **X** appears on the screen. This "always busy" channel will not have been skipped in the next scan period. If this channel needs recover, holding down left-key once again for more than 2 seconds makes **X** disappear. The skip function is cancelled accordingly. Besides, it is impossible to skip over the priority channel.

Enter. Use ENTER when navigating menus, to confirm entries and edits.

CH ▲ / ▼

Channel Select. The current channel is shown on the screen in BIG digits with the channel description information below the channel number.

Press **CH ▲ / ▼** to step through the available channels one at a time, or hold down to scroll quickly through all the available channels. See Appendix B for a listing of channel charts.

Alphanumeric Entry. This key can also be used for menu selection and alphanumeric entry. Press **CH ▲ / ▼** to scroll the cursor up or down menu options when navigating menus.

When editing an item that contains only numbers, press - **CH▲** to count through the numbers or hold down to scroll through quickly.

To enter a character, press **CH▼** to step through the alphabet or hold down to scroll through quickly.

HI/LO/ ✕

Transmission Power. High (HI) 5W or Low (LO) 1W. Press to toggle between high or low transmission powers for the entire channel bank. The **Hi** or **Lo** selection is shown on the LCD screen.

Some channels allow only low power transmissions. Error beeps will sound if the power transmission setting is incorrect.

Some channels allow only low power transmissions initially, but can be changed to high power by holding down HI/LO and PTT all at the same time. See Appendix B for a complete listing of channel charts.

✕ hold down and enter GPS Satellite mode.

WX/NAV

Quickly press to access WX channel (US/Canada only).

The channel is used mostly for weather. Press again to return to your previous mode. Hold down **WX/NAV** for more than 3 seconds to enter Navigation mode Bearing, Distance and cross track error from the last select Way Point will display on the screen. If no WP is set, it will appear "NO ACTIVE ROUTE!!" prompt.

NAV. Press NAV to enter Navigation mode Bearing, Distance and cross track error from the Waypoint will display on screen. If no WP is set, it will appear "NO ACTIVE ROUTE!!" prompt.

GO/MOB

Press GO / MOB if you are navigating to waypoint and want to reset the XTE (cross track error) as shown on the screen.

If someone falls overboard, holds down GO / MOB for about 3 seconds to mark the position.

The latitude and longitude of the Man Overboard position is shown on the screen and is automatically set as the destination waypoint.

PTT

Push To Talk. Push to start the transmitting

CALL/MENU

Quickly press the CALL/MENU key to access the DSC Call menu. The call mode is used for making DSC calls. Hold down the Key more than 3 seconds to access the Menu Setup mode and to customize your VHF radio. **US only**

MENU. Quickly press the MENU key to access the Menu setup mode and to customize your VHF radio (EU only).

Please refer to the following sections for more details.

CAUTION

BATTERY CAUTION: This device uses a Lithion Ion battery - please observe the following cautions.

- Do not disassemble.
- Do not incinerate or expose to fire.
- Dispose of used batteries according to local codes and requirements.

Section 3 - VHF Radio Operation

3-1 Batteries and Charger

The radio is shipped with a sealed Li-Polymer battery pack that is rechargeable.

WARNING

The charger provided for this radio is only to be used to charge the battery pack provided. DO NOT charge any other type of batteries in the charger as fire, explosion or battery damage will occur. Avoiding extreme room temperature will also help prolong the life of the battery pack for the radio.

3-1-1 Installing the Battery Pack

1. Position the battery pack to line up the three external alignment tabs to the alignment slots in the radio.
2. Engage the battery pack into the radio until battery pack is fully seated against the radio housing.
3. Pivot the locking tab up until it snaps into place on the back of the battery pack.

3-1-2 Initial Charge

You can either charge the Li-Polymer battery pack when it is attached to the radio or separated:

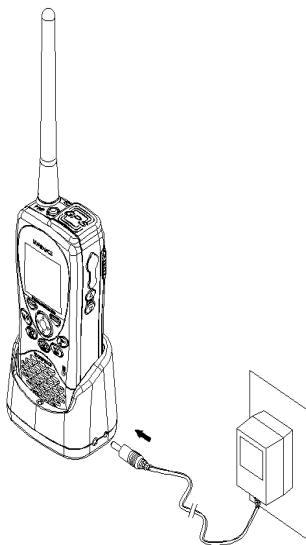
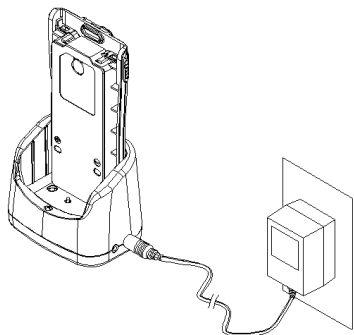

1. Plug in the AC/DC wall charger- check the voltage is correct for your wall charger.
2. Connect the charging wire into the charging socket on the cradle charger.
3. Insert the entire radio or the separated battery pack into the cradle charger. The metal charge contacts on the radio will contact the mating prongs in the charger to transfer the charging current.
4. Observe that the red light on the front of the charger glows to indicate that the battery pack is properly seated and the charger is operating.
5. Allow the batteries to charge for about 2.5 to 3 hours before use. The light will change back to green when the battery is fully charged.

CAUTION

To maximise battery life: remove the battery from the charger after approximately 3.5 hours. Overcharging batteries may result in damage to both the battery pack and radio.

3-1-3 GPS Connector

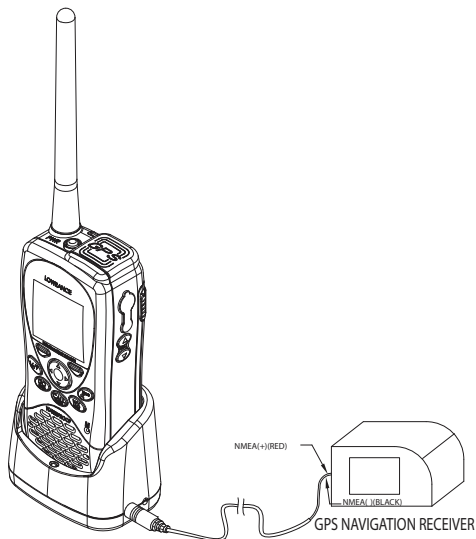

This radio supports NMEA0183 for outputting the GPS signal. You can use the GPS connector to connect the radio and some GPS navigation receiver, such as chart plotter.

1. Insert one single port of the GPS connector cord into the NMEA socket of the cradle charger.
2. The other port of the GPS connector, which is branched into two wires, connects to the GPS navigation receiver. Red means NMEA OUT(+); Black means NMEAOUT(-).

Wire Color	Function
Red	NMEA OUT(+)
Black	NMEA OUT(-)

3-1-4 Mounting Battery Charger to flat surface

You can mount the battery charger straight onto solid surface. Make sure that the surface can be penetrated and is strong enough to hold permanently in place.

To mount the battery charger onto a flat surface, insert screws into place-holders and turn in a clockwise motion until firmly locked into place.

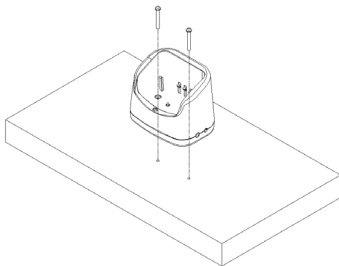

3-1-5 Mounting Battery Charger and bracket onto wall

You can also mount the battery charger onto wall by using the provided bracket and screws.

1. Insert screws into bracket, and turn in a clockwise motion until locked firmly into place.
2. Insert screws into battery charger and mount it to bracket. Turn screws in clockwise motion until firmly locked into place.

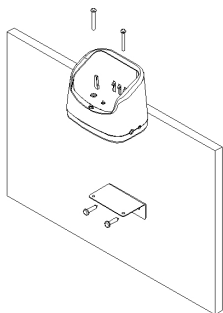

To remove battery from unit:

1. Slide the two levers (simultaneously) in a downward motion.
2. Remove battery.

3-2 Installing the Belt Clip

1. The fitted buckle (2) allows you to attach the radio to the belt clip, so you can carry it.

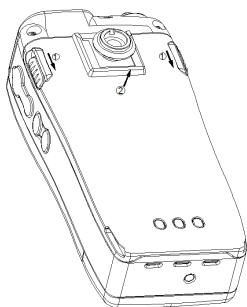

2. The belt clip supplied with your radio allows you to attach the radio to your belt.
3. To install the belt clip, slide the belt clip to the back of your radio, make sure that the buckle is aligned.

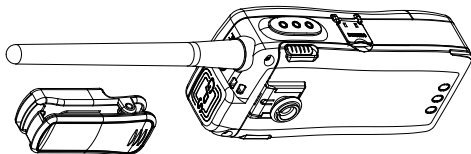

3-3 Installing and Removing the Antenna

Make sure that the flexible antenna is attached to the radio. Ensure that the radio is turned OFF anytime that the antenna is not connected.

Installing the antenna:

1. Screw the antenna in a clockwise motion until it is securely locked into place.

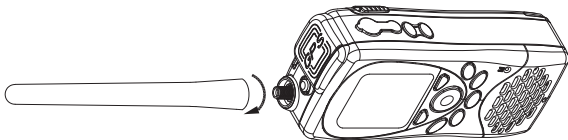

Removing the antenna:

2. Unscrew the antenna in a anti-clockwise motion until it is removed (as illustrated below).

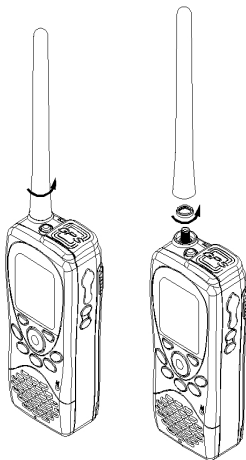

Note: Do not operate the radio or press PTT key without the antenna being installed.

3-4 Power On/Off

You can turn on the unit by pressing PWR/  switch (on the top side of radio) until the screen and backlight are on. You can also adjust the volume to a comfortable level, by pressing the VOL ▲/ ▼ keys on the side of unit.

Note: Press the PWR/  key can turn on the backlight at anytime.

3-5 Adjusting the Squelch level

The SQUELCH control enables you to set the levels of your desired signal. It determines how strong your signal can be before you can hear it, before it “breaks squelch.” It aims to keep any static, unwanted, weak or distant signals from interrupting your conversations.

There are 16 signals to choose from when adjusting the squelch level. To increase the levels, raise the “Squelch Gate” higher so that only stronger signals can get through. Level “0” for instance, means that there is no “Squelch Gate” and everything will get through.

To adjust the squelch level, press SQ ◀/ ▶ accordingly.

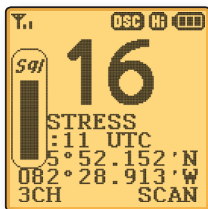

3-6 Volume control

Press VOL ▲/ ▼ to adjust the volume level. A volume sub-menu will appear when pressed. It times-out after 5 seconds.

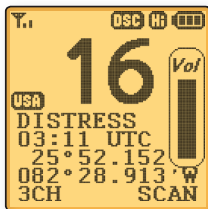

3-7 Channel selection

To manually select a channel, press CH ▲ to increase, or press CH ▼ to decrease the channel number. Communication channels are located on channel 01-28 and 60-88. For more detailed channel chart information, refer to Appendix B.

16/9 (Priority channel)

LVR-80 (US only).

1. Press to cancel all other modes and tune into the priority channel on Hi power.
2. Press again to return to your original channel.
3. Channel 16 is the default. To make Channel 09 the default instead, hold down 16/9 until a beep sounds and 09 is displayed.

16 (Priority channel)

LVR-80 (EU only).

1. Press to cancel all other modes and tune into the priority channel on Hi power.
2. Press again to return to original channel.

3-8 Receiving and transmitting

CAUTION

Transmitting without an antenna may damage the radio.

1. To turn power on, press the PWR key for more than 2 seconds
2. Adjust for comfortable volume level. (The squelch level temporarily set to "0")
3. Set the suitable Squelch level to mute noise if necessary.
4. Press CH ▲ / ▼ to select the desired channel.

When receiving a signal, **R** appears on screen and audio is emitted from the speaker.

Further volume adjustment may be needed to get your desired setting.

5. Press HI/LO to select the output power.

Choose low power to conserve battery power, or choose high power for longer distance communications.

6. Press and hold "PTT" to transmit, then speak into the microphone, while **T** appears on the screen.
7. Release PTT, to receive conversation.

Note: Some channels are for low power only. Channel 70 cannot be used for transmission.

For clear and audible transmission:

- Pause for a few seconds after pressing PTT.
- Hold the microphone 5 to 10 cm (2 to 4 inches) away from your mouth and speak at a normal volume.

3-9 Dual Watch Operation

Dual watch monitors channel 16 while receiving another channel. To activate this, you must:

1. Select the desired operating channel (e.g. CH88A).
2. Push the SCAN key repeatedly until **DW** appears on screen
3. To cancel dual watch, press SCAN (once) until **DW** disappears.

If a signal is received on channel 16, dual watch pauses on channel 16 until the signal disappears.

To transmit on the selected channel during dual watch, press and hold PTT.

3-10 3CH Operation (Favorite Channel)

You can instantly access the three most frequently used channels by 3CH mode, Three Favorite Channels. Press to toggle between your favorite channels. The **1**, **2**, or **3** symbols appear on the LCD to show which of your favorite channel is selected.

3-10-1 Add a favorite channel for the first time

1. Select the desired channel, then hold 3CH to store it. The CH1 **1** symbol appears on the screen.
2. Repeat the procedure to store two more favorite channels in the CH2 and CH3 locations.

3-10-2 Modify or Delete favorite channel

If you try and add another favorite channel it will overwrite the existing CH3. But CH1 and CH2 will remain unless you delete them.

To delete a favorite channel:

- Select that channel, then hold down 3CH until a dialogue box appears to prompt the deletion.

3-11 Scan Operation

Scanning is an effective way to locate signals quickly over a wide frequency ranger.

All Scan

All channels in the set are scanned sequentially, in repeated cycles (CH16 is checked every 1.5 seconds).

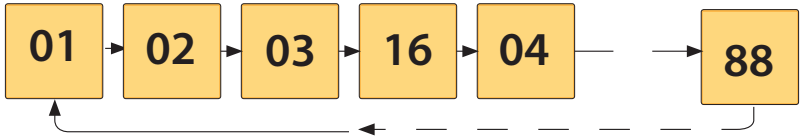

3CH Scan

Press and hold down the SCAN key in the 3CH mode, you will then enter a 3CH SCAN mode. However, only the 3CH and CH16 will be scanned.

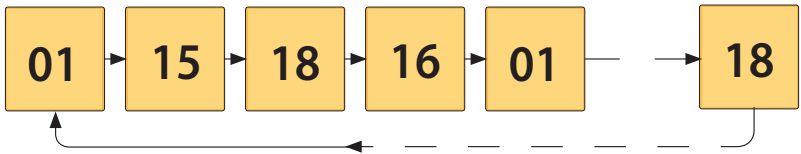

3-12 Navigation Mode

Press and hold down NAV key, (US only), or just press the NAV key (EU only) to enter the Navigation Mode. It will display: Bearing, Distance and cross track error from the last selected waypoint.

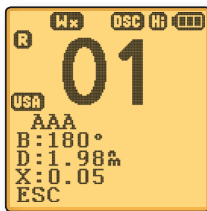

If no WP is set, 'NO ACTIVE ROUTE!!' will appear to prompt you that no WP is selected.

During Nav Mode:

- PTT – return to normal mode and TX.
- 16/9 – return to normal mode and go to 16/9

- NAV – return to normal mode
- GO – Reset the cross track error (XTE)
- SQL ► – Go to WP select Mode
- SQL ◀ – Go to Plotter Mode
- Other key – error beep

3-13 WP Select Mode

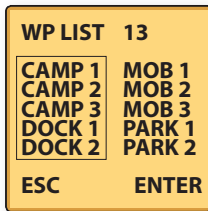

- CH ▲ / ▼ – Page up down the list;
- SQL ◀ – Go to Plotter Mode;
- SQL ► – Returns to Navigation Mode

Note: During WP Select Mode, press ENTER right-key to flash the first WP, then press CH ▲ / ▼ to select next WP, press ENTER right-key again to set the WP as your next destination and enter navigation mode.

3-14 Plotter Mode

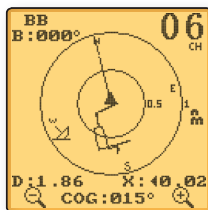

During plotter Mode:

- Soft Key It will zoom in/out the circle to see more/less area.
- SQL ◀ Go to Navigation Mode

- SQL ► Go to WP select Mode
- PTT Return to normal mode and TX.
- 16/9 Return to normal mode and go to 16/9
- NAV Go to normal mode
- Other key Error beep

3-15 GPS Satellite Mode

Press and hold the HI/LO/✕ key to enter GPS satellite mode.

During GPS satellite mode:

- PTT Return to normal mode and TX.
- 16/9 (16) Return to normal model and go to 16/9
- ✕ Return to normal mode
- Left soft-key Return to normal mode
- Other key Error Beep

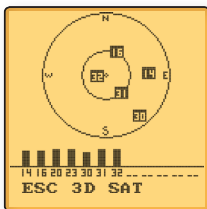

Section 4 - Advanced Operation

How to Display and Navigate Menus

1. Hold down CALL / MENU key to enter in menu (US only); or press MENU key to enter setup mode (EU only).
2. Press CH ▲/▼ to scroll up and down the menu until the cursor is positioned at the desired items. Press soft-key ENTER to enter into the items.
3. Press soft-key ENTER to confirm changes. Otherwise, press soft-key ESC to ignore.
4. Press soft-key ESC to go back or exit. Any changes are activated as soon as you enter/exit the screen.

How to Enter Alphanumeric and Alphabet Data

Use the CH ▲/▼ key to enter characters.

1. Press ▼ to enter and count through numbers and letters, and hold down to select the desired character.
2. Press ▲ to go through letters of the alphabet, and hold down to select the desired character.
3. Press ENTER to confirm.

The following options are available through MENU:

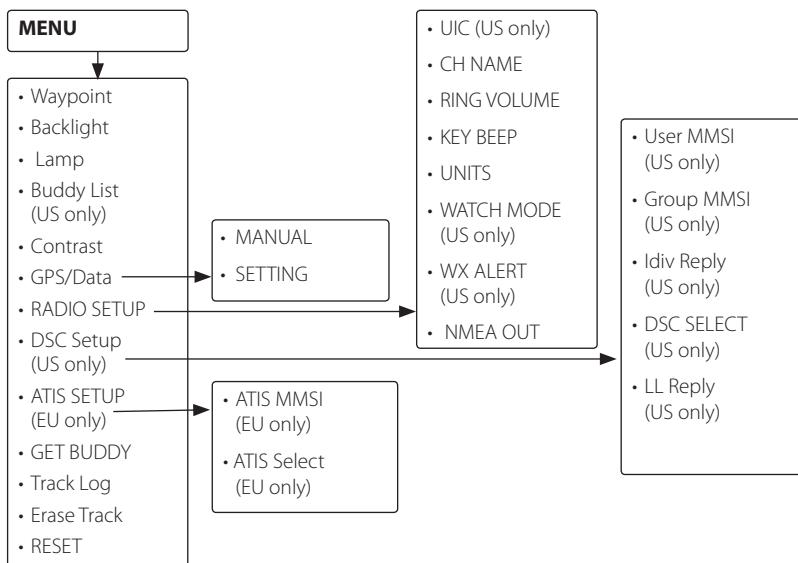

Hold down the CALL/ MENU key to enter radio set-up mode. This allows the following functions to be accessed. Scroll down the list and press ENTER. To exit the Menu or sub-menu modes press 16 or EXIT.

- WAYPOINT** Select the WP List Entry to enter names and LL positions for a WP. Up to 500 WP can be stored.
- BACKLIGHT** Sets the backlight level, 8 levels are available.
- LAMP** Sets the Lamp timer.
- BUDDY LIST** Selects the Buddy List Entry to enter names and MMSI's for regularly called DSC stations. Up to 20 names can be stored (US only).
- CONTRAST** Selects display contrast setting: 1-4 levels.
- GPS/DATA** Define the display POS and Time, format, Offset and COG/SOG display and GPS alert, GPS enabled and Bearing.
- RADIO SETUP** There are 7 items that can be customized, they are: Band, CH Name, Ring Tone Volume, Beep Volume, Units, Watch mode, WX alert
- DSC SETUP** There are 5 functions that allow user to change., they are: User MMSI enter, Group MMSI, INDIV RELAY AND LL Relay (US only).
- ATIS SETUP** There are 2 functions that allow user to change: ATIS MMSI Enter, ATIS Select. (EU Only).
- GET BUDDY** Enable or disable Buddy Data and Auto Function.
- TRACK LOG** Set the distance interval for recording the track points.
- ERASE TRACE** Whether erase all track history points.
- RESET** Resets factory settings.

Set-up Menu Navigation

To access the Menu Mode:

- press and hold CALL/MENU key, or press MENU key. Text area displays the Set-Up Menu list.
1. Press the 16 or ESC soft key to exit from the menu.
 2. Press the CH ▲/ ▼ to select the Item within the Set-Up Menu list. To confirm a selected item, push ENTER soft-key.
 3. Or use CH ▲/ ▼ knob to enter alphanumeric or alphabet data.
 4. To confirm a selected item, push ENTER soft-key.
 5. Turn unit off. All changes are saved to EEPROM.

4-1 Buddy List (Manage your buddy list. US only)

You can use the buddy list to store names and associated MMSIs of 20 DSC stations that you call frequently. Buddy names are stored in the order of entry, with the most recent entry first.

The following sections demonstrates how to use BUDDY LIST, these include: to add, edit, and delete entries.

4-1-1 Add a new buddy name

You can enter up to 20 buddy names. When your BUDDY LIST is full, you cannot make a new entry until you have deleted an existing entry.

- Each buddy name can have a maximum of 11 alphanumeric characters.
- The most recent buddy name entered is shown at the top of your buddy list.



1. Hold down CALL/MENU for 3 seconds.
2. Select BUDDY LIST then press ENTER.
3. The cursor is at <MANUAL>. Push ENTER.
4. Use the CH ▲/▼ to enter the new buddy name one character at a time. Then press ENTER until the cursor moves to the MMSI entry line.
5. Use CH ▲/▼ to enter the 9-digit MMSI that is associated with that buddy name, one number at a time, then press ENTER.
6. After you enter the last digit of the MMSI, a new screen appears automatically to show the new buddy name and MMSI. Checks that it is correct; and then push ENTER to save the new entry. (If it is not correct, select ESC).

4-1-2 Edit a buddy name



1. Press and hold down CALL/MENU for about 3 seconds.
2. Select BUDDY LIST then press ENTER.
3. Scroll down to the entry you want to edit then press ENTER .
4. The buddy name is displayed and the cursor is positioned at EDIT. Press ENTER
5. The buddy name and MMSI are displayed. The cursor is at the first character of the name.
6. Use CH ▲/▼ to change the first character of the buddy name then press ENTER, or just press ENTER to skip to the next character. Repeat if necessary. When you reach the last character of the buddy name, make any changes if needed, then press ENTER to move the cursor to the MMSI.

Note: If you do not want to change the buddy name, just press ENTER repeatedly until the cursor moves to the MMSI line.

7. To change the MMSI, use CH ▲/▼ to change the first number or press ENTER to skip to the next number. Repeat if necessary. When you reach the last number, press ENTER to display the SAVE screen.

Note: If you do not want to change the MMSI, press ENTER repeatedly until the SAVE screen appears.

8. Press ENTER to save the edits or CANCEL to keep the original entry.

4-1-3 DELETE a buddy name

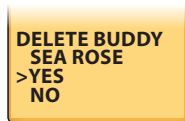

1. Hold down CALL MENU for about 3 seconds.
2. Select BUDDY LIST. Press ENTER to display the list of buddy names.
3. Scroll down to the buddy name you want to delete then press ENTER.
4. Select DELETE then select YES.
5. The buddy name is deleted and the revised buddy list is displayed.

4-2 Waypoint

You can store up to 500 waypoints and their LL positions. When your WAYPOINT LIST is full, you cannot make a new entry until you have deleted an existing one.

- Each waypoint name can have a maximum of 6 alphanumeric characters.
- The most recent waypoint name will be displayed at the top of your waypoint list.

4-2-1 Add a new waypoint

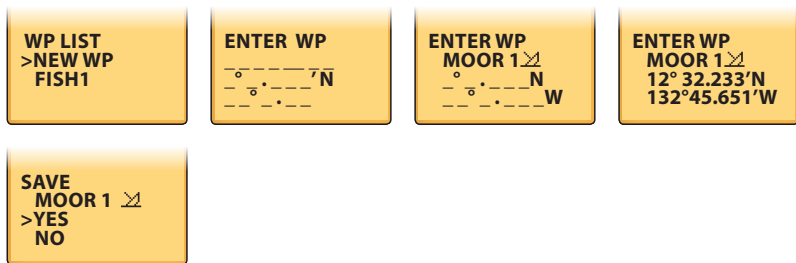

1. Hold down CALL MENU for 3 seconds (US ONLY); or press MENU key (EU only).
2. The cursor is at WAYPOINT, press ENTER.
3. Select WP LIST, and then NEW WP.
4. Use the CH ▲ / ▼ to enter the new waypoint name, one alphanumeric character at a time. Select one waypoint symbol (there are 20 icons available); and then press ENTER until the cursor moves to the latitude line.
5. Use the CH ▲ / ▼ to enter the latitude of the waypoint, one number at a time; then press ENTER. The cursor moves to the longitude.
6. Use the CH ▲ / ▼ to enter the longitude waypoint, one number at a time, then press ENTER.
7. A new screen appears automatically to show the new waypoint details. If they are correct, press ENTER to STORE the new waypoint. (If they are not correct, select ESC).

4-2-2 Edit a waypoint

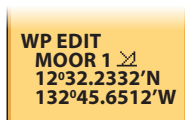
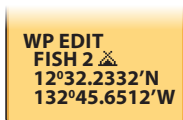

1. Hold down CALL MENU (US only); or press MENU (EU only).
2. The cursor is at WAYPOINT. Press ENTER.
3. Select WP LIST, then push ENTER, the cursor is at new WP. Scroll down to the waypoint you want to edit then push ENTER.
4. Select WP EDIT and press ENTER.
5. The waypoint details are displayed and the cursor is positioned at the first character of the name.
6. Use the CH ▲ / ▼ to change the first character of the waypoint name then press ENTER, or just press ENTER to skip to the next character.

When you reach the last character of the waypoint name, make any changes if necessary, then press ENTER to move the cursor to the waypoint icon.

Note: If you do not want to change the waypoint name waypoint icon, press ENTER repeatedly until the cursor moves to the latitude.

To change the waypoint icon, use the CH ▲ / ▼ to change the icon or press ENTER to skip to latitude. To change latitude, use the CH ▲ / ▼ to change the first digit or press ENTER to skip to the next digit. Repeat if necessary. When you reach the last digit, push ENTER to move the cursor to longitude.

Note: If you do not want to change the latitude, press ENTER repeatedly until the cursor moves to the longitude.

1. Repeat the previous step to change or press ENTER to continue.
2. A new screen appears. Press ENTER if you want to STORE the new waypoint. If you want to keep the original entry, move the cursor to NO then press ENTER.

4-2-3 Delete a waypoint

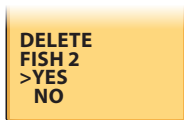

Hold down CALL MENU for about 3 seconds (US only); or press menu (EU only).

1. The cursor is at WAYPOINT, press ENTER.
2. Select WP list and press ENTER. The cursor is at new WP, scroll down to the waypoint you want to delete, then press ENTER.
3. The cursor is at GO. Move the cursor to delete and push ENTER.
4. The waypoint is deleted immediately and the revised waypoint list is displayed.

4-2-4 Set a route to a stored waypoint



1. Hold down CALL/MENU for about 3 seconds (US only); or press MENU (EU only).
2. The cursor is at WAYPOINT. Press ENTER.
3. The cursor is at WP list, press ENTER. The cursor is at new WP, scroll down to the waypoint to use as the routes then press ENTER.
4. The cursor is at GO and push ENTER and enter the navigation mode. The waypoint is set as your next destination.

4-3 Backlight Adjustment

1. Select BACKLIGHT and press ENTER. There are 8 contrast levels.
2. SQ ◀/▶ to adjust the setting. Press ENTER to confirm the setting and return to the MENU SELECT.



4-4 Lamp Adjustment

1. Select LAMP and press ENTER. The backlight has 4 levels for the LCD: Always on, 5s, 15s and 30s (default).
2. Press CH ▲/▼ to adjust the setting. Press ENTER to confirm the setting and return to the MENU SELECT.



4-5 Contrast Adjustment

1. Select CONTRAST and press ENTER. There are 8 contrast levels. The higher the numbers, the darker LCD screen.
2. SQ ◀/▶ to adjust the setting, Press ENTER to confirm the setting and return to the MENU SELECT.

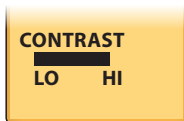

4-6 GPS/DATA

You can use the GPS/DATA menu to:

- manually enter your position data,
- manually enter the time data,
- show or hide your position,
- show or hide the time; and
- offset the UTC time to show your local time.
- Format the time display, and
- show or hide your course (COG) and speed (SOG).
- Turn GPS ENABLE ON/OFF.
- Set True or Magnetic Heading.

Choose NO GPS DATA alarm sound is ON/OFF. Your radio can automatically detect and updates your position and time data.

Note: This information is important because it will be used if you send a DISTRESS call.

If GPS data is not available, the NO GPS alert will sound for 5 seconds (or until you press any button) and the screen will request you to enter the position data manually.

This will repeat every four hours if you do not enter the position data manually. After you have entered the position data, you must update it within 23.5 hours otherwise NO GPS alert sequence repeats.

The GPS DATA LOST indicator is shown whenever GPS data is not available from an operational GPS navigation receiver.

4-6-1 Manual (Manually Enter Your Position and UTC Time)

Note: This option appears only when the NO GPS icon is shown to indicate that GPS data is not available.

Use the GPS/DATA menu to manually enter your latitude and longitude and the UTC (time data).

If GPS receives data automatically - all manual entries will be erased.

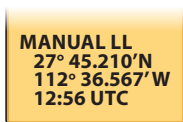
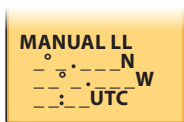

1. Select GPS/DATA in radio setup MENU.
2. The cursor is at MANUAL. Push ENTER.
3. The cursor is at the first latitude position.
4. Use the CH ▲ / ▼ to enter the latitude one number at a time. Press ENTER to move cursor to the longitude line.
5. Use the CH ▲ / ▼ to enter the longitude coordinates one number at a time. Press ENTER to move cursor to the UTC line.
6. Use the CH ▲ / ▼ to enter the UTC one number at a time then press ENTER.
7. After you enter the last number of the UTC, a new screen appears automatically to show the position and time data. The prefix M indicates a manual entry. If you made a mistake, repeat these steps to enter the correct data.

4-6-2 Settings: LL Display (Show or hide your position)

If your position and time data is being updated automatically, you can use LL DISPLAY to choose whether to show or hide your position on the screen.



1. In menu move the cursor to GPS/DATA and press ENTER.
2. Move the cursor to SETTING and press ENTER.
3. Move the cursor to LL Display and press ENTER.
4. The cursor is at ON (to show your position).

If you want to hide your position, move the cursor to OFF. Press ENTER to confirm your selection.

4-6-3 Settings: Time Display (Show or hide the time)

If your position and time data is being updated, you can use TIME DISPLAY for to choose whether to show or to hide the time on the screen.



1. In radio setup menu, move the cursor to GPS/DATA and press ENTER.
2. Move the cursor to SETTING and press ENTER.
3. Move the cursor to TIME DISPLAY and press ENTER.
4. The cursor is at ON (to show the time).
If you want to hide the time, move the cursor to OFF.
5. Press ENTER to confirm the selection.

4-6-4 Time Offset (Local time)

If your position and time data is being updated, you can use TIME OFFSET to enter the time difference between UTC and local time - so your local time is displayed on the screen.



1. Work out the time difference between UTC and your local time.
2. In the radio set-up menu select GPS/DATA and press ENTER.
3. The cursor is at SETTING and press ENTER.
4. The cursor is at TIME OFFSET and press ENTER.
5. Enter + or – followed by the time difference between UTC and your local time. Half hour increments can be used (as in this example). Local time is shown with the suffix LOC.
6. Press ENTER to confirm the selection.

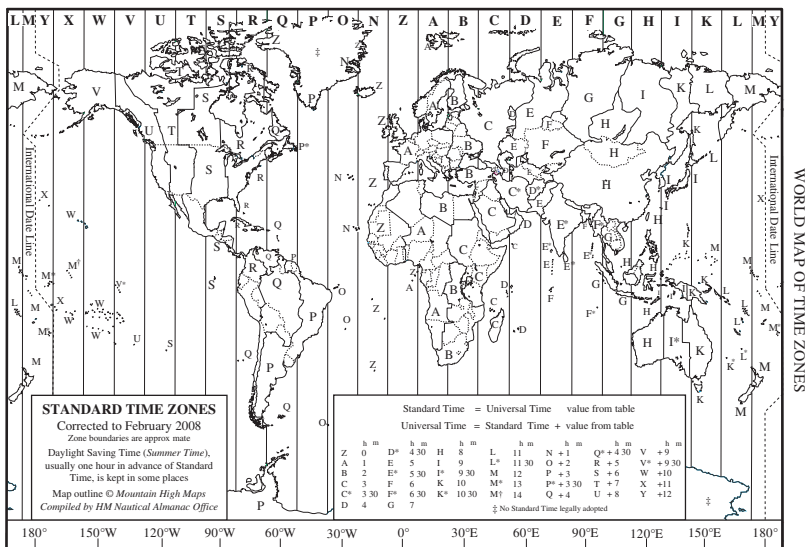

4-6-5 Settings: Time Format (12 or 24 hour clock)

Use TIME FORMAT to show the time in 12 or 24 hour format, depending on your preference.



1. In the radio set-up menu select GPS/DATA and press ENTER.
2. Move the cursor to SETTING and press ENTER.
3. Move the cursor to TIME FORMAT and press ENTER.

The cursor is at 12 HR (to show the suffix: am or pm).

If you want to use the 24 Hr clock, move the cursor to 24 HR.

4. Press ENTER to confirm the selection.

4-6-6 Settings: COG/SOG (Course & speed display options)

If your position and time data is being updated, you can use COG/SOG to choose whether to show or hide your course over ground (COG) and speed over ground (SOG) data on the screen.

Note: Despite the COG/SOG setting, if TIME DISPLAY is ON, the course and speed will not display on screen.

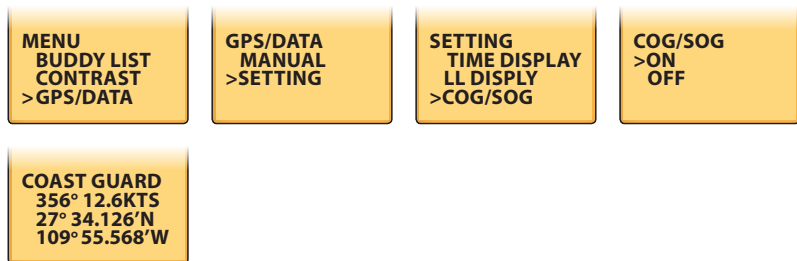

1. In radio set-up menu select GPS/DATA and press ENTER.
2. Move the cursor to SETTING and push ENTER.
3. Move the cursor to COG/SOG and push ENTER.
4. Select ON or OFF as desired, In this example, ON has been selected, so the screen shows the bearing and speed.

If COG/SOG is set on, the time is NOT display on the screen.

4-6-7 GPS Alert

You can choose NO GPS DATA alarm sound is on/off.



1. In the radio setup menu, select GPS/DATA then SETTING, next select GPS ALERT.
2. Select ON/OFF as desired, in this example, ON has been selected, so if GPS DATA is not available, the NO GPS alert will sound.

4-6-8 Turn GPS ENABLE on/off



1. In radio set-up menu, select GPS/DATA then SETTING, next GPS ENABLED.
2. Select ON/OFF as desired, in this example, ON has been selected, so the GPS ENABLED is turned ON.

4-6-9 Set True or Magnetic Bearing

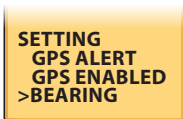

1. In radio set-up menu, select GPS/DATA then SETTING, next BEARING.
2. Select TRUE/MAG VAR as desired, then press ENTER to confirm.

Note: True is the default.

If MAG VAR is selected. Then use CH ▲ / ▼ to adjust the MAGNETIC difference between true and variation, then press ENTER to confirm selection.

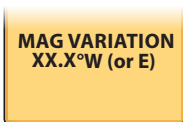

Note: W is the default and tenths of a degree is required.



4-7 Radio Setup

Under Radio Setup submenu, there are 7 items that user can alter settings.



4-7-1 UIC (US only)

You can select the: USA, International, or Canadian channel band. The channel bands are listed in the appendix sections.



1. In the radio setup submenu select RADIO SETUP then press ENTER.
2. The cursor is at UIC, press ENTER.
3. The cursor is at USA.

If you want to select the International channel band, move the cursor to INT'L. If you want to select the Canadian channel band, move the cursor to CANADA.

4. Press ENTER to confirm your choice.
5. The new channel band is selected. Depending on your choice, the USA, INT'L, or CAN icon is shown on the screen.

4-7-2 Channel Name Editing

To setup the channel name to ON or to blank on the first line, Maximum of 12 characters could be set for channel name. Channel name also allows editing, the ways same as Buddy List edit procedures.

1. Select RADIO SETUP, CH NAME, and then press ENTER. Then select the desired channel name by using the CH ▲/▼. Press ENTER then the screen will show the channel name, EDIT and DELETE.
2. Select EDIT and press ENTER to edit the existing name tag. Input the new name over the existing one and press ENTER to display the YES/NO confirmation.

To delete the channel name, just select DELETE then press ENTER.

3. Press ENTER to confirm the new channel name and then press cancel to return to the menu.



4-7-3 Ring Volume Adjustment

1. Select the RING VOLUME by pressing CH ▲ / ▼ and choose your preference by selecting the option – HIGH or LOW as ringer tone setting.
2. Press ENTER again to confirm the changes.



4-7-4 Beep Volume Adjustment

1. Select the KEY BEEP, then press CH ▲ / ▼ to select one of the following options will be displayed: HIGH, LOW/OFF as your key beep settings.
2. Press ENTER again to confirm.



4-7-5 Select Unit (UNITS)

You can select your preferred measurement units for distance and cross track error.

1. Select RADIO SETUP, then units.
2. Select your preferred measurement units and press ENTER.



4-7-6 Set the Priority Channel (WATCH MODE) US Only

If you are operating on the USA or Canada Channel banks. You can have the priority channel to cover both CH16 and CH09 as well as the working channel, similar to a TRI WATCH.

1. Select RADIO SETUP, and then WATCH MODE.
2. Select the desired setting, and then press ENTER.



4-7-7 WX Alert (Weather alerts)

Note: LHR-80 US only.

The NOAA provides several weather forecast channels on US and Canadian channel banks.

If severe weather such as storms or hurricanes are forecast, the NOAA broadcasts a weather alert on 1050 Hz.

You can choose to watch weather alerts.



1. Select RADIO SETUP then WX ALERT.
2. The cursor is ON (NOAA weather alerts on 1050 Hz on normal mode). If you do not want to watch these weather alerts, move the cursor to OFF.
3. Press ENTER for to confirm your selection.

If you chose to receive the weather alerts, the beeps will sound whenever a weather alert is broadcast. Just press any button to hear it.

4-7-8 Set NMEA OUT (NMEA OUT)



This radio supports to output NMEA 0183 sentence of DSC & DSE.

1. Select RADIO SETUP then NMEA OUT.
2. Select ON/OFF then press ENTER to confirm your desired choice.

4-8 DSC Setup (US only)

The submenu is used to set behavior of the function. Items are available for selection. Hold down CALL/MENU then select DSC SETUP, press ENTER to enter DSC SETUP submenu in which there are 5:

User MMSI

Group SETUP

INDIV REPLY

DSC SELECT

LL REPLY

4-8-1 Enter or check your USER MMSI

Note: You must enter your user MMSI before you can access the DSC functions.

When you have entered your MMSI correctly, you can display it any time.

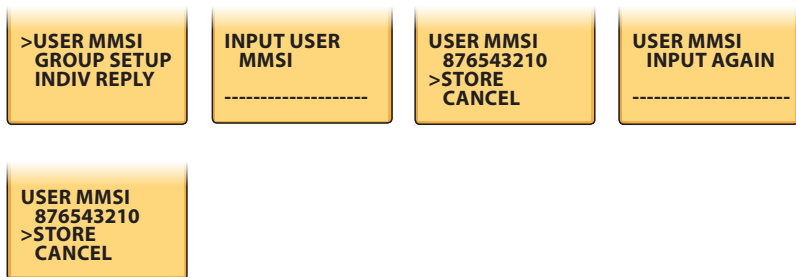

1. The cursor is at DSC SETUP and press ENTER.
2. The cursor is at USER MMSI. Press ENTER.

If you have already entered your MMSI, it is shown on the screen.

If this is the first time that you are entering your MMSI, a dashed line appears with the cursor under the first position. You need to enter your MMSI along the dashed line, one number at a time.

3. Press CH ▲/▼ to select the first number of your MMSI. Press ENTER to confirm the number and move to the next position. If you make an error, select the < character then press ENTER to backup.

- When you have entered the last number, push ENTER to advance to the next screen. The cursor is at STORE.
- Check whether the displayed MMSI is correct, then press ENTER to store, or CANCEL to backup.
- Enter your MMSI again as a password check, then push ENTER to permanently store the user MMSI and return to the MENU.

You can view your stored user MMSI at anytime by selecting USER MMSI in the setup menu.

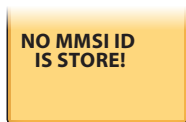

DSC warning message.

4-8-2 Maintain Groups

You can program up to three group MMSI numbers and associated Group names. Group MMSI numbers always begin with a zero (0). You only enter the last 8 digits of the group ID number, the initial "0" is automatically entered.

4-8-2-1 Enter your Groups

Use GROUP MMSI to create, edit, or delete 1, 2, or 3 groups of people that you call frequently. The entries within a group are stored in alphanumeric order. A group MMSI always has nine numbers and always starts with 0.

A group name can have a maximum of 12 alphanumeric characters.



- Select DSC SETUP then GROUP SETUP.
- If this is FIRST TIME that you're entering a group name, no group appears. Otherwise, any existing group names. The cursor is at MANUAL NEW.
- Use CH ▲/ ▼ to enter the new group name, one alphanumeric character at a time.
- Press ENTER to confirm each correct alphanumeric character and to move to the next position.

- When you have entered the group name, push ENTER so the cursor moves to the MMSI line.
- Use CH ▲/▼ to enter the MMSI associated with that group name, one number at a time. Pushes ENTER to confirm a number and move to the next position.
- If you make an error, select the < character then press ENTER.
- When you have entered the last number of the MMSI, a new screen appears automatically.
- The cursor is at STORE, check that it is correct and, if so push ENTER to save the new entry. (If it is not correct, select CANCEL).

4-8-2-2 Edit user Groups

You can change a group name or group MMSI at any time.



- Select DSC SETUP then GROUP SETUP.
- The names of your groups are displayed. Move the cursor to the group you want to edit and push ENTER.

The group name and MMSI are displayed, the cursor is at the EDIT, press ENTER.

- Use the CH ▲/▼ to change the group name. Or, to edit only the MMSI press ENTER repeatedly until the cursor moves to the MMSI line.

If you need to change the MMSI associated with that group name, use CH ▲/▼ to change the number then press ENTER.

If you do not need to change the MMSI, press ENTER repeatedly to step through the MMSI and then press ENTER.

- When you are finished, press ENTER to display the next screen.
- The cursor is at STORE, press ENTER to save the new entry or select CANCEL to ESC.

4-8-2-3 Delete a Group

- Select GROUP SETUP and press ENTER. The existing group names are displayed on screen.
- Select what you want to delete and press the ENTER. It will display EDIT or DELETE item.
- Select DELETE and press ENTER. It will display DELETE GROUP menu; arrow points to YES, then press the ENTER to empty the group and return to the GROUP SETUP screen. The LCD displays the group as follow.

EILEEN
053421608
EDIT
>DELETE

DELETE GROUP
EILEEN
>YES
NO

GROUP SETUP
MANUAL
SAILING
FISHING 2

4-8-3 Response to Individual Calls

You can respond to an incoming call with either: an automatic response or, with a manual response.

An automatic response sends an acknowledgement and sets-up the channel ready for a conversation..

A manual response asks if you want to acknowledge the call, and then asks if you want to converse with the caller.

DSC SETUP
USER MMSI
GROUP SETUP
>INDIV REPLY

INDIV REPLY
MANUAL
>AUTO

1. Select DSC SETUP, then select INDIV REPLY.
2. The cursor is a AUTO, press ENTER for an automatic response, or select MANUAL for a manual response.

4-8-4 DSC Select

To turn off the DSC function temporarily, such as sailing to inland water or no DSC region.

1. Select DSC SETUP, then DSC SELECT, press the ENTER to displays DSC SELECT ON/OFF.
2. Select OFF to turn the DSC function off.
3. Press ENTER to confirm your choice and return to the menu.

DSC SETUP
GROUP SETUP
INDIV REPLY
>DSC SELECT

DSC SELECT
ON
>OFF

4-8-5 LL Reply

You can set the radio to respond to the Position Request. It can be done in three ways, auto-matic, manual, and off.

1. Select DSC SETUP, then LL REPLY. Then press ENTER, the MANUAL, AUTO, OFF appear on the screen.
2. Select your response and press ENTER to confirm and return to the menu manual.



4-9 ATIS SETUP (EU only)

The submenu is used to adjust settings for the ATIS function.

- Press MENU and then select ATIS SETUP, press ENTER to enter the submenu.

4-9-1 Enter or Check your ATIS MMSI

If you are navigating in the inland waterways of Europe, then you must enter your ATIS MMSI to access ATIS functionality.

An ATIS MMSI always starts with 9 and it sends a digital message whenever you release the PTT button.

When you have entered your ATIS MMSI correctly, you can display it any time.



1. Select ATIS SETUP then ATIS MMSI and press the ENTER. If an existing MMSI is stored, the values appear.
2. If the MMSI is blank, a dashed line will appear, except for the initial number '9'. Then enter ATIS MMSI along the dashed line. Press ENTER to confirm each entry and then move to the next line.
3. If you make an error, press CH▼ until < appears, then press the ENTER to backup and correct the entry.

- When you have entered the last number of the MMSI, a confirmation screen appears. The cursor is at STORE, press ENTER to store your ATIS MMSI.
- Enter your ATIS MMSI again as a password and check the confirmation screen appears again, select STORE and press ENTER to permanently store your ATIS MMSI and return to the menu.
- You can view your stored ATIS MMSI at anytime by selecting ATIS MMSI in the ATIS SETUP menu.

4-9-2 ATIS Select

When ATIS is enabled, the following occurs:

- DUAL watch, Tri Watch and scan functions are disabled.

The following international channels are limited to 1 watt output power:

6, 8, 10, 11, 12, 13, 14, 15, 17, 71, 72, 74, 75, 76, 77 (AND31, if enabled)

To enable/disable ATIS:



- Select ATIS SETUP, then ATIS SELECT. Press ENTER to display ATIS SELECT ON/OFF.
- Select ON to turn the ATIS function on.
- Press the ENTER to confirm your choice and return to the menu.

4-10 Get Buddy

Enable or Disable data auto function (GET BUDDY)

Enable buddy mode: Radio will transmit your LL data to the opposite after you release the PTT key, if the opposite is GET BUDDY ON also, it will show the distance and USER MMSI (or ATIS MMSI) of the sender.



- Select GET BUDDY and then press ENTER.
- Select ON or OFF as required, then press ENTER to confirm the selection.

Note: For EU, use clone software to Enable/Disable the GET BUDDY menu.

4-11 Track Log

Set the distance interval to 25m, 50m, or 100m for recording the track points when driving.



1. Select TRACK LOG, then press ENTER, the 25m, 50m, 100m appear on the screen.
2. Select your desired and press ENTER to confirm.

4-12 Erase Track

Erase the track history line by this menu. So the track line will disappear on the plotter mode's screen.



1. Select ERASE TRACK, then press ENTER, the radio asks for confirmation.
2. Select Yes, then press ENTER to erase the track line of the plotter screen.

4-13 Reset (Reset to factory defaults)

Use RESET to return every setting on the radio to the factory defaults, except your MMSI, Group MMSIs and ATIS MMSI.



1. Select RESET, press ENTER, the radios asks for confirmation.
2. Select yes, press ENTER to reset the radio and return to the menu.

Section 5 - Sending and Receiving DSC Calls (US only)

5-1 What is DSC?

Digital Selective Calling (DSC) is a semi-automated method of establishing a radio call. It has been assigned by the International Maritime Organization (IMO) as an international standard for establishing VHF, MF and HF radio calls.

It had also been assigned as part of the Global Maritime Distress and Safety System (GMDSS). It is planned that DSC will eventually replace aural watches on distress frequencies and will be used to broadcast routine and urgent maritime safety information.

This new service will also allow mariners to initiate or receive distress, urgency, safety and routine calls to or from another vessel that is equipped with a DSC transceiver.

Calls can be categorized as distress, urgency, safety, or routine and DSC. It selects a working channel automatically.

Details of the 20 most recent incoming DSC calls are stored in your call log.

Details of the 10 most recent distress calls are stored in your distress log.

CAUTION

Due to EU regulations, DSC is not available in the LHR-80E (EU) model.

5-1-1 Maritime Mobile Service Identity

An MMSI is a nine-digit number used on Marine Transceiver capable of using Digital Selective Calling (DSC). This number is used like a telephone number to selectively call other vessels.

5-1-2 How can I obtain a MMSI assignment?

Contact your local dealer.

WARNING

This radio is designed to generate a digital maritime distress and safety call to facilitate search and rescue. To be effective as a safety device, this equipment must be used only within communication range of a shore – based VHF marine channel 70 distress and safety watch system. The range of signal may vary but under normal conditions should be approximately 20 nautical miles.

Quickly press the DSC/MENU key to pop up the DSC menu. Users can then select the DSC call type to send. The channel remains unchanged and allows normal Tx operation.

5-2 DSC Call Types

Press the CALL/MENU key to access the menu for user to select the DSC call type to send.

Note: Only 4 calls can be shown at any one time on the screen.

Press CH ▲ / ▼ scroll up and down the call types until the cursor is positioned at the desired option.

Press the ENTER the call types are:

Call Type	Description
INDIVIDUAL	Make a new call, by inputting the MMSI or pick up from the list max 20
LAST CALL	Recalls last call no matter what type of call it is.
GROUP	Sends transmissions that are only received by radios that share a common group MMSI number, there is up to 3 group MMSI numbers can be stored and called.
ALL SHIPS	Makes an Urgency, Safety or Routine call to all ships. A confirmation screen follows the priority selection of these options. The Safety call is for advisory alert only.
CALL LOG	Allows a review of all stored calls by number and time of call. An individual call type can be placed to the selected MMSI/NAME in the LOG. The LOG contains all received call types except DISTRESS calls. The call at the end of the list is automatically erased. The earliest call is stored at the end of the list.
	Note: Only 20 calls can be stored at one time.
DISTRESS LOG	Allows a review of all stored Distress calls by number and time of call. An individual call type can be placed to the selected MMSI / NAME in the LOG. The call at the end of the list is automatically erased. This means the earliest call is stored at the end of the list. There are only 10 calls that can be stored.

LL REQUEST Enables you to request GPS position information from any vessel that has a known MMSI number. The request can be picked up through the buddy list or manual entry.

TRACK BUDDY Track the GPS position information from up to three vessels that have a known MMSI number.

5-2-1 Send an Individual call

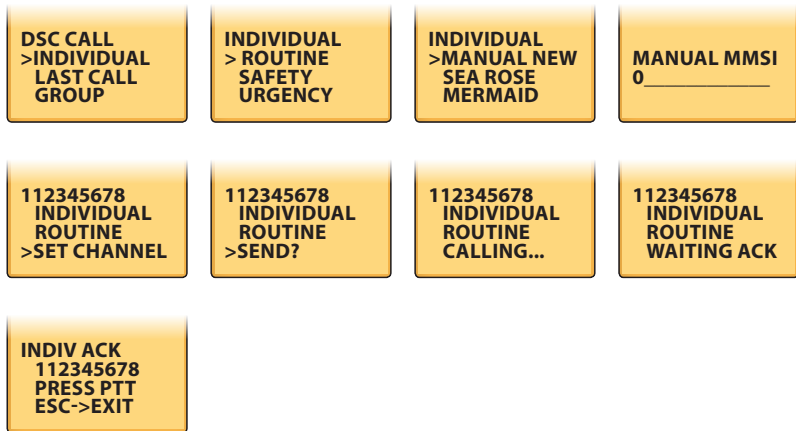

You can call anyone who has an DSC equipped radio.

To call another person:

1. Press CALL/MENU to enter DSC mode, then select INDIVIDUAL.
2. The cursor is at ROUTINE. Press ENTER to make a routine call or select to another priority level: SAFETY or URGENCY.
3. Select MANUAL NEW to call a person that is not in your buddy list, otherwise select the name of your buddy. Press ENT. If you selected MANUAL NEW, you need to enter the user MMSI and then press ENT.
4. Select the working channel and press ENT. (Note: Duplex channels cannot usually be called and are automatically eliminated from the suggested call list. If the call is to a Coast Station, the radio will recognize this and select the correct channel).
5. The radio summarizes the call details and asks for confirmation to send the call (SEND?). Press ENT to send the call. The radio goes to CH70 and the Tx is displayed on the screen while the DSC call is being sent.

- If the call is acknowledged (ACK), press PTT to talk. If there is no reply, try making the call again.

5-3 Send a Group Call

You should have already stored the GROUP MMSI before making the call. Group calls are always sent with ROUTINE priority.

DSC CALL
INDIVIDUAL
LAST CALL
>GROUP

GROUP
>RD GROUP
GROUP #2
GROUP #3

RD GROUP
012345678
ROUTINE
>SET CHANNEL

RD GROUP
012345678
ROUTINE
>SEND?

RD GROUP
012345678
ROUTINE
CALLING...

- Press CALL/ MENU to show the DSC CALL menu.
- The cursor is at LAST CALL. Move the cursor to GROUP and push ENTER. The names of your groups are displayed.
- Select the group that you want to call and press ENTER.
- Select the working channel and press ENTER to SEND the call.

Note: Duplex channels cannot usually be called and are automatically eliminated from the suggested call list.

The Tx icon is displayed on the screen while the call is being sent.

5-4 Send an All Ships call

DSC CALL
LAST CALL
GROUP
>ALL SHIPS

ALL SHIPS
>ROUTINE
SAFETY
URGENCY

ALL SHIPS
ROUTINE
> SET CHANNEL

ALL SHIPS
ROUTINE
>SEND?

ALL SHIPS
ROUTINE
CALLING L ...

1. Press CALL/MENU to show the DSC CALL menu.
2. The cursor is at LAST CALL Move the cursor to ALL SHIPS and press ENTER.
3. The ALL SHIPS priority is set automatically to ROUTINE but there are 3 priority levels available:

URGENCY: when a serious situation or problem has occurred and could lead to a distress situation.

SAFETY: to send safety information to all other boats in range.

ROUTINE: to send a routine call to all other boats in range.

4. Move the cursor to the priority level that is appropriate to your present situation then press ENTER.
5. Select the working channel and press Enter. Duplex channels which are not usually called are automatically eliminated from the suggested call list.
6. The radio asks for confirmation of the ALL SHIPS call. Press ENTER to select YES and send the ALL SHIPS call.
7. The Tx icon is displayed on the screen while the call is being sent.
8. If the call is acknowledged press PTT to speak.

5-5 Reply to a call in your Call Log

Your call log contains the contact details of the 20 most recent incoming calls - so you can use the call log to reply to any of these quickly. When the call log is full, the oldest entry is overwritten. Therefore, to select the priority level:

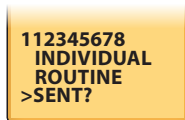

1. Press call/menu to show the DSC CALL menu.
2. The cursor is at last call.
3. The contact details of the most recent incoming call are shown.

- (Optional) If you want to save this log entry in your BUDDY LIST, move the cursor to MMSI then press ENTER and enter a buddy name. The MMSI is automatically displayed.
- The cursor is at CALL BACK. Press ENTER.
- Select the working channel and press ENTER.

Note: Duplex channels cannot usually be called and are automatically eliminated from the suggested call list. If the call is to a Coast Station, the channel is selected automatically.

- The call details are shown. Pushes ENTER to send the call. The Tx icon is shown on the screen while the call is being sent.
- If the call is acknowledged, press PTT to talk.
- If there is no reply (UNABLE TO ACKNOWLEDGE), a message asks if you want to retry (SEND AGAIN?).
- Select YES, then press ENTER to retry the call.

This cycle repeats twice. If the call still cannot be placed, the radio returns to normal operation.

5-6 Reply to a call in your Distress Log

Your distress log contains the contact details of the 10 most recent relayed distress calls, so that you can reply to any of these quickly. When the distress log is full, the oldest entry is overwritten to select the priority level.

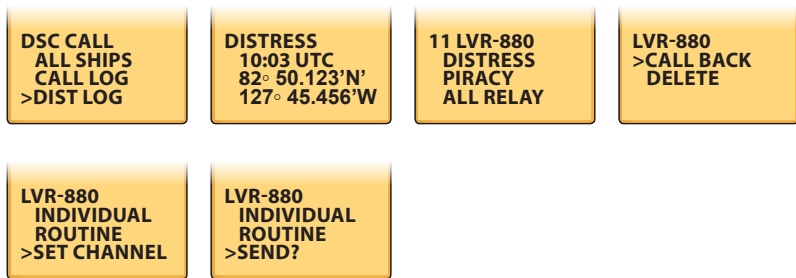

- Press DSC MENU to show the DSC CALL menu.
- The cursor is at LAST CALL. Move the cursor to DIST CALL and push ENTER.
- The contact details of the most recent incoming distress call are shown as the first entry (01) in the distress log. Move the cursor to step through the distress calls and select the entry that you want to call.

The details are displayed over two screens that alternate every 1.5 seconds: one screen shows the location and UTC time of the boat in distress. The other screen shows the nature of the emergency (if specified) and the MMSI of the boat that relayed the distress call.

4. The cursor is at CALL BACK. Press ENTER.
5. Select the working channel and press ENTER.

Note: Duplex channels cannot usually be called and are automatically eliminated from the suggested call list. If the call is to a coast station, the channel is selected automatically.

6. The call details are shown. Press ENTER to send the call.
The Tx icon is shown on the screen while the call is being sent.
7. If the call is acknowledged, press PTT to talk.
8. If there is no reply (UNABLE TO ACKNOWLEDGE); a message asks if you want to retry (SEND AGAIN?).
9. Select YES, then push ENTER to retry the call.
This cycle repeats twice. If the call still cannot be placed, the radio returns to normal operation.

5-7 Reply to the Last Call

Your call log contains the contact details of the 20 most recent incoming calls. Use LAST CALL to reply quickly to the most recent call.

Select the priority level as follows:



1. Press CALL/MENU to show the DSC CALL menu.
2. The cursor is at LAST CALL, push ENTER.
The contact details of the most recent incoming call are displayed.
3. Select the working channel and press ENTER.

Note: Duplex channels cannot usually be called and are automatically eliminated from the suggested call list. If the call is to a coast station, the channel is selected automatically.

4. The call details are shown. Press ENTER to send the call. The Tx icon is displayed on the screen while the call is being sent.
5. If the call is acknowledged, press PTT to talk.
6. If there is no reply (UNABLE TO ACKNOWLEDGE), a message asks if you want to retry (SEND AGAIN?).
7. Select YES and then press ENTER to retry the call. This cycle repeats twice. If the call still cannot be placed, the radio returns to normal operation.

5-8 Request the LL position of a buddy (LL Request)

DSC CALL
CALL LOG
DIST LOG
>LL REQUEST

LL REQUEST
>SAM
VHF7200
BUDDY #3

SAM
LL REQUEST
>SEND?

SAM
LL REQUEST
CALLING ...

SAM
LL REQUEST
WAITING ACK

1. Press CALL/MENU to enter DSC MENU, then select LL REQUEST.
2. Select the buddy whose LL position you want to request, then press ENT to send the request.
3. The working channel name is displayed while the radio waits for an acknowledgement from your buddy. If there is no reply after 30 seconds, the radio asks if you want to retry.

5-9 Track Your Buddy (Track Buddy)

Use the TRACK LIST option to select a buddy (or buddies) whose position you want to track. Specify the time interval through the INTERVAL option, to start the track alternatively. If the buddy name and time interval are already set to your preference, just start tracking.

5-9-1 Add or Delete a Buddy (Buddy List)

DSC CALL
DIST LOG
LL REQUEST
>TRACK BUDDY

TRACK BUDDY
START TRACK
SET BUDDY
> TRACKLIST

TRACKLIST
> ADD NEW
SAM

ADD NEW
>KATHY
SEA ROSE

TRACKLIST
> ADD NEW
KATHY
SAM

1. Press CALL/MENU to enter DSC MENU, then select TRACK BUDDY.
2. Select TRACKLIST. Any buddies that are already on the track list will be listed.

Note: To delete a buddy from the track list, select the buddy that you want to delete, then press ENTER. Select Yes and press ENTER to confirm your choice.

3. Select ADD NEW to show your buddy list.
4. Select the target buddy then press ENTER to add that buddy to the track list.

5-9-2 Select your want track's buddy

Select your buddy as follows:



1. Press CALL/MENU to enter DSC MODE, then select TRACK BUDDY.
2. Select SET BUDDY and scroll down to your desired buddy. You can set a maximum of three buddies to track.
3. Select ON to track that buddy, or OFF to not to. Press ENTER to confirm. (Repeat for the other two buddies if necessary.)

5-9-3 Set the time interval of tracking

Set the time interval as follows:



1. Press CALL/MENU to enter DSC mode, then select TRACK BUDDY.
2. Select INTERVAL, and choose the desired time interval. Press ENTER to confirm.

5-9-4 Start Tracking

Start tracking as follows:



1. Press CALL/MENU to enter DSC mode, then select TRACK BUDDY.
2. Select START TRACK, then YES.
3. (The START TRACK display changes to STOP TRACK. To stop tracking at any time, just press YES.)

As soon as you start tracking, an LL Request is sent immediately on CH70 and your radio; and it waits for acknowledgement of the (first) buddy's LL position to be displayed on your radio screen.

Each of the selected buddies is polled for their LL positions at regular time intervals.

When information is received, a friendly ring tone sounds and the position is shown on the screen. Pressing any key cancels the screen.

The position that is received is not stored in your radio's Log, but is broadcast over NAVBUS to the Chartplotters. Press any key to acknowledge, or wait for the automatic 20 second timeout.

Note: The LHR-80 is capable of receiving and displaying the LL position data at normal or enhanced resolution.

5-10 Receive an All Ships call

1. The DSC icon on the screen flashes and the call alert sounds when the radio receives an ALL SHIPS call from another boat or a coast station within range. A call alert with a friendly two-tone cycle indicates a ROUTINE call.

A call alert with a cycle of 6 beeps followed by a 2 second pause indicates an URGENCY or DISTRESS call.
2. Press any button to cancel the call alert. The radio is switched to the designated channel by pressing ENTER, or return to the old channel by pressing ESC. The priority level and the user MMSI are shown on the screen. If the radio recognizes the user MMSI as one of your buddies, the buddy name is shown in place of the user MMSI.
3. Press PTT to initiate voice contact on CH16 and then switch to a working channel; OR press ESC if you do not want to make voice contact. The call data is stored in your call log.

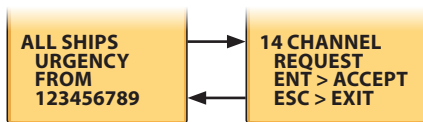

5-11 Receive a Group call



1. The DSC icon on the screen flashes and a friendly two-tone call alert sounds when the radio receives a GROUP call all from one of your 3 designated groups. A GROUP call always has ROUTINE priority.

2. Press any button to cancel the call alert. No acknowledgement is required. The radio automatically selects the channel designated in the incoming GROUP call. The group name is shown on the screen. If the radio recognizes the GROUP MMSI as one of your groups, the group name is shown in place of the MMSI.
3. Press PTT to initiate voice contact on designated channel and then switch to a working channel, OR press ESC if you do not want to make voice contact.

The call data is stored in your call log.

5-12 Reply to an LL position request

Your radio can automatically, or manually turn OFF to an incoming LL request caller depending on the LL REPLY setting.

5-12-1 Manually reply to an LL Request

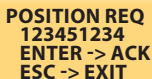

POSITION REQ
123451234
ENTER -> ACK
ESC -> EXIT

When the radio receives an LL position request it beeps to alert you. Meanwhile, the LCD screen displays the position request and the MMSI of the caller.

1. If you press ESC, or do not respond to the request within five minutes, the radio returns to its previous state.
2. Press ENTER to acknowledge the call and transmit your position on CH70 automatically. The LL position request is not stored in the call log.

5-12-2 Automatically reply to an LL position request



POSITION REQ
123451234
ESC->EXIT

When the radio receives an LL position request it beeps to alert you.

Meanwhile the LCD screen displays the position request and the MMSI of the caller. The radio acknowledges the request automatically and immediately sends your boat's position to the caller.

5-12-3 Do not reply to an LL position request

**POSITION REQ
123451234
LL REPLY OFF
ESC->EXIT**

When the radio receives an LL position request, it will beep to alert you. The LCD screen will display, the position request, and the caller's MMSI. The radio will show that the reply facility is OFF. Press <ESC or PTT to return to the previous screen. The LL position request is not stored in the call log.

5-13 Receive an individual call

The radio makes a friendly two-tone alert when it detects an incoming DSC call.

Incoming individual calls are always a priority, and should be part of your protocol.

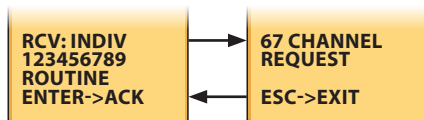

If the radio recognizes the user MMSI as one of your buddies, your buddy's name is displayed. Your radio can automatically or manually reply to the incoming caller depending on the INDIV REPLY settings.

1. Press ENTER to send an acknowledgement to the incoming caller, or LHR-80 automatically sends an acknowledgement to the caller. This stops the two-tone alert. The radio automatically detects the channel of the incoming call.
2. The caller should respond, you can press PTT to initiate contact.

5-14 Receive a Polled Position Call

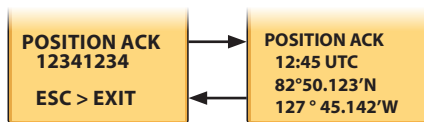

When you receive GPS position data from a buddy in response to your LL request, you are recommended make note of it - especially if it is a good fishing position.

If enhanced LL position information is available, it is shown on the LCD until the display changes.

Section 6 - Distress Calls (US only)

Note: You must have entered a valid user MMSI to send and receive DSC DISTRESS calls.

6-1 Send a Distress Call

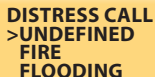

DISTRESS CALL
>UNDEFINED
FIRE
FLOODING



DISTRESS CALL
>UNDEFINED
HOLD DISTRESS
3 SECONDS..

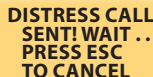

DISTRESS CALL
SENT! WAIT ..
PRESS ESC
TO CANCEL

1. Open the red cover labelled DISTRESS. If you have time to specify the nature of the distress, go to step 2. Otherwise, go directly to step 3.
2. Press the DISTRESS key to display the following categories. Scroll down to the category that best describes your situation, and then press ENT:
 - **UNDEFINED**
 - **FIRE**
 - **FLOODING**
 - **COLLISION**
 - **GROUNDING**
 - **LISTING**
 - **SINKING**
 - **ADRIFT**
 - **ABANDONING**
 - **PIRACY**
 - **OVER BOARD**
3. Hold down the DISTRESS key for about 3 seconds, until you see the distress call sent message (DISTRESS CALL SENT!) on the screen. The whole display starts to flash and beep loudly. The distress call repeats five times continuously. It then repeats randomly every 3.5 to 4.5 minutes until a distress acknowledgement (DISTRESS ACK) is received from a search and rescue authority, or until you cancel the distress call manually.

The radio selects CH16 automatically so that you can hear any incoming voice contacts from search and rescue authorities, or other vessels within range.

Press ESC if you need to cancel the distress call. This is the only key that operates in Distress mode.

6-2 Receive a Distress Call

123456789
DISTRESS
FLOODING
ESC -> EXIT

123456789
10:34 UTC
82 ° 50.003'N
27 ° 45.543'W

1. An alert sounds when a distress call (DISTRESS!) is received. Press any key to cancel the alert. You do not need to send an acknowledgement.
2. The radio automatically selects CH16 and displays the details of the distress call on the screen. Press PTT to establish voice contact.
3. The details are displayed over two screens that alternate every 1.5 seconds; the first screen shows the user MMSI and nature of the emergency (if specified), the second screen shows the time and the location (if specified). If the location and time are not specified, these are replaced with sequences of 9s and 8s respectively.
4. The LHR-80 is capable of receiving enhanced LL position data if the vessel transmitting the Distress Call is sending. It provides the position of the distressed vessel to within 20m (60ft).

6-3 Receive a Distress Relay Call

DISTRESS
RELAY FROM
123456789
ESC -> EXIT

FLOODING
987654321
82 ° 50.003'N
127 ° 45.543'W

When the radio picks up an incoming distress call:

The radio beeps loudly to alert you to the incoming distress call and the working channel changes automatically to CH16. Press any key except PTT or <ESC, if you want to stop the beeps.

At the same time, the LCD screen displays, the category of the distress, the MMSI (or buddy name and the position) of the distressed vessel. After one second, the LCD display changes to show the MMSI of the sender with priority Relay.

1. An alert sounds when a Distress Relay (DISTRESS RELAY) is received. Press any key to cancel the alert.
2. Try to make voice contact with the calling vessel. Maintain a listening watch on CH16 and standby to lend assistance.

6-4 Receive Distress Acknowledgement (DISTRESS ACK)

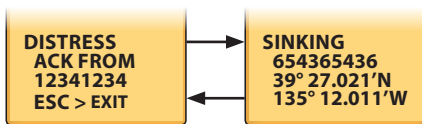

When the radio picks up an incoming distress acknowledgement:

1. The radio beeps loudly for two minutes, to alert you to the incoming distress acknowledgement, the working channel changes automatically to CH16. Press any key except ESC OR 16/9 to stop the beeps.

At the same time, the LCD screen displays the distress acknowledgement and the MMSI (or buddy name) of the vessel sending it. After one second, the LCD screen changes to show the MMSI and position of the distressed vessel, including the type of distress call.

2. Press <ESC or 16/9 to cancel the LCD screen cycle, then press PTT to try and establish voice contact with the coast guard or press <ESC again to maintain a listening watch on CH16.

6-5 Relay a Distress Call from the Distress LOG (RELAY)

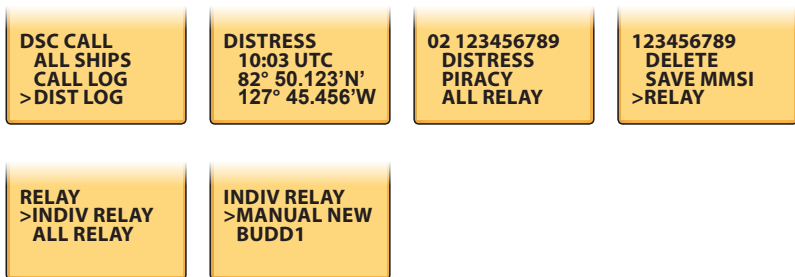

You can Relay a Distress Call from your Distress Log to an individual or to ALL SHIPS.

1. Press CALL/MENU to enter the DSC CALL menu, then select DIST LOG.
2. The most recently received distress call is the first entry(01) in the Distress Log. Select the distress call that you want to relay, then select RELAY.

3. Either select:
 - INDIV RELAY. It relays the distress call to an individual. Select MANUAL NEW if the person is not in your buddy list, otherwise scroll to the name of your buddy. Press ENTER. (If you select MANUAL NEW, you need to enter the user MMSI then press ENTER).
 - ALL RELAY. It relays the distress call to all ships, then press ENTER.
4. The radio automatically selects CH16 (For ALL RELAY), or manually set the working channel (INDIV RELAY). It displays the detail of the distress call on the screen.
5. Press ENTER to Relay the distress call.

Appendix A - Technical Specifications

Lowrance LHR80US & LHR-80EU

A-1 General:

Waterproof	Floating and totally submersible to JIS-7
Channels	All US, Canadian and International Channels 10 NOAA Weather Channels
Frequency Range	Transmit -156.025 to 157.425 MHz Receive - 156.025 to 163.275 MHz (US only) 10 WX Channels (US Only)
Battery	7.4 V high-capacity 1400 mAh Li-Polymer
Battery Life	>8 Hours (with GPS/DSC on and 5W 5/5/90% ratio)
Charging current (with cradle charge)	700±100 mA with 3 hour rapid charge time
Antenna Socket	SMA
Display	128x128 pixel bit-mapped LCD with backlight

A-2 Receiver:

Sensitivity 12 dB SINAD	≤0.25 uV
Squelch sensitivity	Threshold -12 dBμV (EMF)
Adjacent Channel Selection	70 dB
Spurious Response Rejection	70 dB
Intermodulation Rejection	68 dB
Audio Power Output	250 mW at 5% THD, 400 mW max

A-3 Transmitter:

Power Output	1 or 5 Watts (Selectable)
Modulation Type	FM
Hum and Noise Attenuation	40 dB
Audio Distortion	5%
Adjacent Channel Power	more than 70 dB
Spurious/Harmonic Emissions	less than -70 dBc
Current drain	Transmit (High) 1.75 A, Transmit (Low) 0.8 A

A-4 GPS and Navigation:

Satellites tracked	12
Navigation	Great Circle navigation display with 500 waypoints
Plotter	12 range scales and 360 point of track history with interval control
Units	NM, SM, KM
NMEA Output	RMC, GGA, GLL, GNS, GSV, DSC, DSE

Appendix B - Frequency Charts

International Marine Channels

CH	TX (MHz)	RX (MHz)	MODE	TRAFFIC TYPE	SHIP TO SHIP	SHIP TO SHORE	NAME TAG	REMARK
01	156.050	160.650	D	Public Correspondence	No	Yes	TELEPHONE	
02	156.100	160.700	D	Public Correspondence	No	Yes	TELEPHONE	
03	156.150	160.750	D	Public Correspondence	No	Yes	TELEPHONE	
04	156.200	160.800	D	Port Operations	No	Yes	PORT OP	
05	156.250	160.850	D	Port Operations, Selected VTS Areas	No	Yes	PORT OPS/VTS	
06	156.300	156.300	S	Inter-ship Safety	Yes	No	SAFETY	
07	156.350	160.950	D	Port Operations	No	Yes	PORT OPS	
08	156.400	156.400	S	Commercial (inter-ship only)	Yes	No	COMMERCIAL	
09	156.450	156.450	S	Recreational Calling Channel	Yes	Yes	CALLING	
10	156.500	156.500	S	Commercial	Yes	Yes	COMMERCIAL	
11	156.550	156.550	S	Commercial, VTS in Selected Areas	Yes	Yes	VTS	
12	156.600	156.600	S	Port Operations, Selected VTS Areas	Yes	Yes	PORT OPS/VTS	
13	156.650	156.650	S	Inter-ship Navigation Safety (bridge-to-bridge)	Yes	No	BRIDGE COM	
14	156.700	156.700	S	Port Operations, Selected VTS Areas	Yes	Yes	PORT OPS/VTS	
15	156.750	156.750	S	Port Operations	Yes	Yes	PORT OPS	⊙ 1W only
16	156.800	156.800	S	International Distress, Safety, and Calling	Yes	Yes	DISTRESS	
17	156.850	156.850	S	State Controlled	Yes	Yes	SAR	⊙ 1W only
18	156.900	161.500	D	Port Operations	No	Yes	PORT OPS	
19	156.950	161.550	D	Commercial	No	Yes	SHIP - SHORE	
20	157.000	161.600	D	Port Operations	No	Yes	PORT OPS	
21	157.050	161.650	D	Port Operations	No	Yes	PORT OPS	
22	157.100	161.700	D	Port Operations	No	Yes	PORT OPS	
23	157.150	161.750	D	Public Correspondence	No	Yes	TELEPHONE	
24	157.200	161.800	D	Public Correspondence	No	Yes	TELEPHONE	
25	157.250	161.850	D	Public Correspondence	No	Yes	TELEPHONE	
26	157.300	161.900	D	Public Correspondence	No	Yes	TELEPHONE	
27	157.350	161.950	D	Public Correspondence	No	Yes	TELEPHONE	
28	157.400	162.000	D	Public Correspondence	No	Yes	TELEPHONE	
60	156.025	160.625	D	Public Correspondence	No	Yes	TELEPHONE	
61	156.075	160.675	D	Port Operations	No	Yes	PORT OPS	

62	156.125	160.725	D	Port Operations	No	Yes	PORT OPS	
63	156.175	160.775	D	Port Operations	No	Yes	PORT OPS	
64	156.225	160.825	D	Public Correspondence	No	Yes	TELEPHONE	
65	156.275	160.875	D	Port Operations	No	Yes	PORT OPS	
66	156.325	160.925	D	Port Operations	No	Yes	PORT OPS	
67	156.375	156.375	S	Commercial, bridge-to-bridge	Yes	No	BRIDGE COM	
68	156.425	156.425	S	Boat Operations, Recreational	Yes	No	SHIP - SHIP	
69	156.475	156.475	S	Port Operations	Yes	Yes	PORT OPS	
70	156.525	156.525		Digital Selective Calling - DSC	-----	-----	DSC	①
71	156.575	156.575	S	Port Operations	Yes	Yes	PORT OPS	
72	156.625	156.625	S	Inter-ship	Yes	No	SHIP - SHIP	
73	156.675	156.675	S	Port Operations	Yes	Yes	PORT OPS	
74	156.725	156.725	S	Port Operations	Yes	Yes	PORT OPS	
77	156.875	156.875	S	Inter-ship	Yes	No	SHIP - SHIP	
78	156.925	161.525	D	Non-Commercial	No	Yes	SHIP - SHORE	
79	156.975	161.575	D	Commercial	No	Yes	SHIP - SHORE	
80	157.025	161.625	D	Commercial	No	Yes	SHIP - SHORE	
81	157.075	161.675	D	Port Operations	No	Yes	PORT OPS	
82	157.125	161.725	D	Port Operations	No	Yes	PORT OPS	
83	157.175	161.775	D	Public Correspondence	No	Yes	TELEPHONE	
84	157.225	161.825	D	Public Correspondence	No	Yes	TELEPHONE	
85	157.275	161.875	D	Public Correspondence	No	Yes	TELEPHONE	
86	157.325	161.925	D	Public Correspondence	No	Yes	TELEPHONE	
87	157.375	161.975	D	Port Operations	No	Yes	TELEPHONE	
88	157.425	162.025	D	Port Operations	No	Yes	TELEPHONE	

Special Notes on International Channel Usage

- ①. LOW POWER (1W) only.
- ②. LOW POWER (1W) initially. Override to HIGH POWER by holding down H/L key before transmitting. Used normally in bridge-to-bridge communications.
- ③. Channel 70 is designated for use exclusively for Digital Selective Calling (DSC), such as Distress, Safety, and Ship Calls. No voice communication is allowed on CH70. This channel is only available on DSC enabled radios.

Note: The INTERNATIONAL mode is not legal for use in US or Canada waters.

KEY: S = Simplex operating channel; D = Duplex operating channel.

USA Channel Chart

CH	TX (MHz)	RX (MHz)	MODE	TRAFFIC TYPE	SHIP TO SHIP	SHIP TO SHORE	NAME TAG	REMARK
01A	156.050	156.050	S	Port Operations, Selected VTS Areas	Yes	Yes	PORT OPS/VTS	
03A	156.150	156.150	S	US Government, Coast Guard	Yes	Yes	UNAUTHORIZED	④
05A	156.250	156.250	S	Port Operations, Selected VTS Areas	Yes	Yes	PORT OPS/VTS	
06	156.300	156.300	S	Inter-ship Safety	Yes	No	SAFETY	
07A	156.350	156.350	S	Commercial	Yes	Yes	COMMERCIAL	
08	156.400	156.400	S	Commercial (inter-ship only)	Yes	No	COMMERCIAL	
09	156.450	156.450	S	Recreational Calling Channel	Yes	Yes	CALLING	
10	156.500	156.500	S	Commercial	Yes	Yes	COMMERCIAL	
11	156.550	156.550	S	Commercial, VTS in Selected Areas	Yes	Yes	VTS	
12	156.600	156.600	S	Port Operations, Selected VTS Areas	Yes	Yes	PORT OPS/VTS	
13	156.650	156.650	S	Inter-ship Navigation Safety (bridge-to-bridge), 1W with Power-up	Yes	No	BRIDGE COM	③ 1W
14	156.700	156.700	S	Port Operations, Selected VTS Areas	Yes	Yes	PORT OPS/VTS	
15	---	156.750	S	Environmental	-----	-----	ENVIRONMENTAL	② RX only
16	156.800	156.800	S	International Distress, Safety, and Calling	Yes	Yes	DISTRESS	
17	156.850	156.850	S	State Controlled	Yes	Yes	SAR	① 1W only
18A	156.900	156.900	S	Commercial	Yes	Yes	COMMERCIAL	
19A	156.950	156.950	S	Commercial	Yes	Yes	COMMERCIAL	
20	157.000	161.600	D	Port Operations, Canadian Coast Guard	No	Yes	PORT OPS	
20A	157.000	157.000	S	Port Operations	Yes	Yes	PORT OPS	
21A	157.050	157.050	S	U.S. Government, Canadian Coast Guard	Yes	Yes	UNAUTHORIZED	④
22A	157.100	157.100	S	Coast Guard Liaison	Yes	Yes	COAST GUARD	
23A	157.150	157.150	S	U.S. Government, Coast Guard	Yes	Yes	UNAUTHORIZED	④
24	157.200	161.800	D	Public Correspondence, Marine operator	No	Yes	TELEPHONE	
25	157.250	161.850	D	Public Correspondence, Marine operator	No	Yes	TELEPHONE	
26	157.300	161.900	D	Public Correspondence, Marine operator	No	Yes	TELEPHONE	
27	157.350	161.950	D	Public Correspondence, Marine operator	No	Yes	TELEPHONE	
28	157.400	162.000	D	Public Correspondence, Marine operator	No	Yes	TELEPHONE	
61A	156.075	156.075	S	U.S. Government, Canadian Coast Guard	Yes	Yes	UNAUTHORIZED	④
63A	156.175	156.175	S	Port Operations, VTS in Selected Areas	Yes	Yes	PORT OPS/VTS	
64A	156.225	156.225	S	U.S. Government, Canadian Commercial Fishing	Yes	Yes	UNAUTHORIZED	④
65A	156.275	156.275	S	Port Operations	Yes	Yes	PORT OPS	
66A	156.325	156.325	S	Port Operations	Yes	Yes	PORT OPS	
67	156.375	156.375	S	Commercial, bridge-to-bridge, 1W with Power-up	Yes	No	BRIDGE COM	③ 1W

68	156.425	156.425	S	Boat Operations, Recreational	Yes	No	SHIP - SHIP	
69	156.475	156.475	S	Boat Operations, Recreational	Yes	Yes	PLEASURE	
70	156.525	156.525		Digital Selective Calling - DSC	-----	-----	DSC	Ⓞ
71	156.575	156.575	S	Boat Operations, Recreational	Yes	Yes	PLEASURE	
72	156.625	156.625	S	Boat Operations, Recreational	Yes	No	SHIP - SHIP	
73	156.675	156.675	S	Port Operations	Yes	Yes	PORT OPS	
74	156.725	156.725	S	Port Operations	Yes	Yes	PORT OPS	
77	156.875	156.875	S	Port Operations	Yes	Yes	PORT OPS	① 1W only
78A	156.925	156.925	S	Boat Operations, Recreational	Yes	No	SHIP - SHIP	
79A	156.975	156.975	S	Commercial	Yes	Yes	COMMERCIAL	
80A	157.025	157.025	S	Commercial	Yes	Yes	COMMERCIAL	
81A	157.075	157.075	S	U.S. Government, Environmental Protection Agency Operations	Yes	Yes	UNAUTHORIZED	④
82A	157.125	157.125	S	U.S. Government, Canadian Coast Guard	Yes	Yes	UNAUTHORIZED	④
83A	157.175	157.175	S	U.S. Government, Canadian Coast Guard	Yes	Yes	UNAUTHORIZED	④
84	157.225	161.825	D	Public Correspondence, Marine Operator	No	Yes	TELEPHONE	
85	157.275	161.875	D	Public Correspondence, Marine Operator	No	Yes	TELEPHONE	
86	157.325	161.925	D	Public Correspondence, Marine Operator	No	Yes	TELEPHONE	
87	157.375	161.975	D	Port Operations	No	Yes	TELEPHONE	
88	157.425	162.025	D	Port Operations	No	Yes	TELEPHONE	
88A	157.425	157.425	S	Commercial, Inter-ship Only	Yes	No	COMMERCIAL	

Special Notes on USA Channel Usage

- ①. LOW POWER (1 W) only.
- ②. Receive Only.
- ③. LOW POWER (1 W) initially. Override to HIGH POWER by holding down H/L key before transmitting. Used normally in bridge-to-bridge communications.
- ④. Lightly shaded simplex channels 03A, 21A, 23A, 61A, 64A, 81A, 82A, and 83A cannot be lawfully used in US waters unless special authorization is obtained from the US Coast Guard. Not for use by the general public.
- ⑤. The letter "A" illuminated by the channel number indicates the USA channel is simplex. This same channel is always duplex when selecting International. There is no "A" reference for International channels. The letter "B" is only used for some Canadian "Receive only" channels.
- Ⓞ. Channel 70 is designated for use exclusively for Digital Selective Calling (DSC), such as Distress, Safety, and Ship Calls. No voice communication is allowed on CH70. This channel is only available on DSC enabled radios.

KEY: S = Simplex operating channel; D = Duplex operating channel.

CANADA Channel Chart

CH	TX (MHz)	RX (MHz)	MODE	TRAFFIC TYPE	SHIP TO SHIP	SHIP TO SHORE	NAME TAG	REMARK
01	156.050	160.650	D	Public Correspondence	No	Yes	TELEPHONE	
02	156.100	160.700	D	Public Correspondence	No	Yes	TELEPHONE	
03	156.150	160.750	D	Public Correspondence	No	Yes	TELEPHONE	
04A	156.200	156.200	S	Canadian Coast Guard, SAR	Yes	Yes	CANADIAN CG	
05A	156.250	156.250	S	Port Operations, VTS in Selected Areas	Yes	Yes	PORT OPS/VTS	
06	156.300	156.300	S	Inter-ship Safety	Yes	No	SAFETY	
07A	156.350	156.350	S	Commercial	Yes	Yes	COMMERCIAL	
08	156.400	156.400	S	Commercial (inter-ship only)	Yes	No	COMMERCIAL	
09	156.450	156.450	S	Recreational Calling Channel	Yes	Yes	CALLING	
10	156.500	156.500	S	Commercial	Yes	Yes	COMMERCIAL	
11	156.550	156.550	S	Commercial, VTS in Selected Areas	Yes	Yes	VTS	
12	156.600	156.600	S	Port Operations, VTS in Selected Areas	Yes	Yes	PORT OPS/VTS	
13	156.650	156.650	S	Inter-ship Navigation Safety (bridge-to-bridge) 1W with power-up	Yes	No	BRIDGE COM	③ 1W
14	156.700	156.700	S	Port Operations, VTS in Selected Areas	Yes	Yes	PORT OPS/VTS	
15	156.750	156.750	S	Commercial	Yes	Yes	COMMERCIAL	① 1W only
16	156.800	156.800	S	International Distress, Safety, and Calling	Yes	Yes	DISTRESS	
17	156.850	156.850	S	State Controlled	Yes	Yes	SAR	① 1W only
18A	156.900	156.900	S	Commercial	Yes	Yes	COMMERCIAL	
19A	156.950	156.950	S	Canadian Coast Guard	Yes	Yes	CANADIAN CG	
20	157.000	161.600	D	Canadian Coast Guard	No	Yes	CANADIAN CG	① 1W only
21	157.050	161.650	D	Port Operations	No	Yes	PORT OPS	
21A	157.050	157.050	S	U.S. Government, Canadian Coast Guard	Yes	Yes	UNAUTHORIZED	
21B	---	161.650	S	Port Operations	-----	-----	PORT OPS	RX only
22A	157.100	157.100	S	Canadian Coast Guard Liaison	Yes	Yes	CANADIAN CG	
23	157.150	161.750	D	Public Correspondence	No	Yes	TELEPHONE	
24	157.200	161.800	D	Public Correspondence	No	Yes	TELEPHONE	
25	157.250	161.850	D	Public Correspondence	No	Yes	TELEPHONE	
25B	---	161.850	S	Public Correspondence	-----	-----	TELEPHONE	RX only
26	157.300	161.900	D	Public Correspondence	No	Yes	TELEPHONE	
27	157.350	161.950	D	Public Correspondence	No	Yes	TELEPHONE	
28	157.400	162.000	D	Public Correspondence	No	Yes	TELEPHONE	
28B	---	162.000	S	Public Correspondence	-----	-----	TELEPHONE	RX only
60	156.025	160.625	D	Public Correspondence	No	Yes	TELEPHONE	
61A	156.075	156.075	S	U.S. Government, Canadian Coast Guard	Yes	Yes	UNAUTHORIZED	②

62A	156.125	156.125	S	Canadian Coast Guard	Yes	Yes	CANADIAN CG	
64	156.225	160.825	D	Public Correspondence, Duplex	No	Yes	TELEPHONE	
64A	156.225	156.225	S	U.S. Government, Canadian Commercial Fishing	Yes	Yes	UNAUTHORIZED	④
65A	156.275	156.275	S	Port Operations	Yes	Yes	PORT OPS	
66A	156.325	156.325	S	Port Operations	Yes	Yes	PORT OPS	① 1W only
67	156.375	156.375	S	Commercial, SAR	Yes	No	COMMERCIAL	
68	156.425	156.425	S	Boat Operations, Recreational	Yes	No	SHIP - SHIP	
69	156.475	156.475	S	Commercial Fishing Only	Yes	Yes	COMMERCIAL	
70	156.525	156.525	S	Digital Selective Calling - DSC	-----	-----	DSC	⑥
71	156.575	156.575	S	Boat Operations, Recreational	Yes	Yes	PLEASURE	
72	156.625	156.625	S	Inter-ship	Yes	No	SHIP - SHIP	
73	156.675	156.675	S	Commercial Fishing Only	Yes	Yes	COMMERCIAL	
74	156.725	156.725	S	Commercial Fishing Only	Yes	Yes	COMMERCIAL	
77	156.875	156.875	S	Port Operations	Yes	Yes	PORT OPS	① 1W only
78A	156.925	156.925	S	Boat Operations, Recreational	Yes	No	SHIP - SHIP	
79A	156.975	156.975	S	Commercial	Yes	Yes	COMMERCIAL	
80A	157.025	157.025	S	Commercial	Yes	Yes	COMMERCIAL	
81A	157.075	157.075	S	U.S. Government Operations	Yes	Yes	UNAUTHORIZED	④
82A	157.125	157.125	S	U.S. Government, Canadian Coast Guard	Yes	Yes	UNAUTHORIZED	④
83	157.175	161.775	D	Canadian Coast Guard	Yes	Yes	CANADIAN CG	
83A	157.175	157.175	S	U.S. Government, Canadian Coast Guard	Yes	Yes	UNAUTHORIZED	④
83B	---	161.775	S	Canadian Coast Guard, RX Only	-----	-----	CANADIAN CG	
84	157.225	161.825	D	Public Correspondence, Marine Operator	No	Yes	TELEPHONE	
85	157.275	161.875	D	Public Correspondence, Marine Operator	No	Yes	TELEPHONE	
86	157.325	161.925	D	Public Correspondence, Marine Operator	No	Yes	TELEPHONE	
87	157.375	161.975	D	Port Operations	No	Yes	TELEPHONE	
88	157.425	162.025	D	Port Operations	No	Yes	TELEPHONE	

Special Notes on Canada Channel Usage

- ①. LOW POWER (1 W) only.
- ②. Receive Only.
- ③. LOW POWER (1 W) initially. Override to HIGH POWER by holding down H/L key before transmitting. Used normally in bridge-to-bridge communications.
- ④. Lightly shaded simplex channels 21A, 23A, 61A, 64A, 81A, 82A, and 83A cannot be lawfully used in Canada waters unless special authorization is obtained from the Canadian Coast Guard. Not for use by the general public.

WEATHER Channels

CH	RX (MHz)	TRAFFIC TYPE	NAME	REMARK
WX01	162.550	NOAA Weather Channel	NOAA WX	RX only
WX02	162.400	NOAA Weather Channel	NOAA WX	RX only
WX03	162.475	NOAA Weather Channel	NOAA WX	RX only
WX04	162.425	NOAA Weather Channel	NOAA WX	RX only
WX05	162.450	NOAA Weather Channel	NOAA WX	RX only
WX06	162.500	NOAA Weather Channel	NOAA WX	RX only
WX07	162.525	NOAA Weather Channel	NOAA WX	RX only
WX08	161.650	CANADIAN Weather Channel	CANADA WX	RX only
WX09	161.775	CANADIAN Weather Channel	CANADA WX	RX only
WX10	163.275	NOAA Weather Channel	NOAA WX	RX only

Appendix C - EU Inland Waterway Channels

Country Specific table

For specific channel information for your country, please refer to local authorities.

CH	SPECIFIC FOOTNOTES	TRANSMITTING FREQUENCY (MHZ)		SHIP-TO-SHIP	SHIP-TO PORT	NAUTICAL INFORMATION
		SHIP	LAND			
60	a)	156.025	160.625			x
01	a)	156.05	160.65			x
61	a)	156.075	160.675			x
02	a)	156.1	160.7			x
62	a)	156.125	160.725			x
03	a)	156.15	160.75			x
63	a)	156.175	160.775			x
04	a)	156.2	160.8			x
64	a)	156.225	160.825			x
05	a)	156.25	160.85			x
65	a)	156.275	160.875			x
06	a) b)	156.3	156.3	x		
66	a)	156.325	160.925			x
07	a)	156.35	160.95			x
67	a) c)	156.375	156.375			x
08	a) q)	156.4	156.4	x		
68	a)	156.425	156.425			x
09	a) b) c)	156.45	156.45			x
69	a)	156.475	156.475			x
10	e)	156.5	156.5	x		
11		156.55	156.55		x	
71		156.575	156.575		x	
12		156.6	156.6		x	
72	a) r)	156.625	156.625	x		
13	f)	156.65	156.65	x		
73	f) g)	156.675	156.675			x
14	q)	156.7	156.7		x	
74	a)	156.725	156.725		x	
15	h) j)	156.75	156.75			x
75	o) j)	156.775	156.775		x	
16	i)	156.8	156.8			x

76	j) d) o)	156.825	156.825			x
17	h) j)	156.85	156.85			x
77	a) k)	156.875	156.875	x		
18		156.9	161.5			x
78		156.925	161.525			x
19		156.95	161.55			x
79	a)	156.975	161.575			x
20		157	161.6			x
80		157.025	161.625			x
21	a)	157.05	161.65			x
81	a)	157.075	161.675			x
22		157.1	161.7			x
82	l) m)	157.125	161.725			x
23	m)	157.15	161.75			x
83	a) m)	157.175	161.775			x
24	m)	157.2	161.8			x
84	m)	157.225	161.825			x
25	m)	157.25	161.85			x
85	a) m)	157.275	161.875			x
26	m)	157.3	161.9			x
86	a) m)	157.325	161.925			x
27	m)	157.35	161.95			x
87	a) d)	157.375	157.375			x
28	m)	157.4	162			x
88	a) p)	157.425	157.425			x
AIS 1	a) n)	161.975	161.975			
AIS 2	a) n)	162.025	162.025			

General remarks to Country Specific table:

- 1 The channels for service categories ship-to-ship and nautical information may also be used for vessel traffic -systems by traffic centres.
- 2 In some countries, frequencies certain channels are used for an other service category or other radio services. These countries are Austria, Bulgaria, Croatia, the Federal Republic of Yugoslavia, Hungary, Moldova, Romania, the Russian Federation, the Slovak Republic, the Czech Republic (with exemption of channels 08, 09, 72, 74 and 86), Ukraine and the Federal Republic of Yugoslavia. The Administrations concerned should make any possible attempt to make these frequencies channels as soon as possible available for the radiotelephone service on Inland Waterways and/or the required service category.

Explanation of specific footnotes in Country Specific table:

- a. In the countries mentioned under remark 2, it is strictly prohibited to use this channel.
- b. This channel is not allowed to be used between Rhine km 150 and km 350.
- c. In the Netherlands, this channel is used by its on-scene communications during safety operations on the North Sea, IJsselmeer, Waddenzee, Ooster- and Westerschelde.
- d. This channel may also be used for piloting, mooring, tugging and for other nautical purposes.
- e. This channel is the first ship-to-ship channel, unless the competent authority has designated an other channel. In the countries mentioned under remark 2, it is allowed that the output power is set to a value between 6 and 25 W until 1 January 2005.
- f. In the countries mentioned under remark 2, this channel is used for service category ship-to-port authorities.
- g. In the Netherlands, this channel is used by its national coastguard for communications during oil pollution operations on the North Sea and for safety messages for the North Sea, Waddenzee, IJsselmeer, Ooster- and Westerschelde.
- h. This channel may be used only for service category on-board on board communications.
- i. This channel may be used only for communications between seagoing vessels and participating land stations in case of distress and safety communications within the maritime sea-areas. In the countries mentioned under remark 2, this channel may be used only for distress, safety and calling.
- j. The output power shall be reduced automatically to a value between 0.5 and 1 W.
- k. This channel may be used for communications with a social character.
- l. In the Netherlands and Belgium, this channel may be used for transmitting messages concerning bunkering and victualling. The output power has to be reduced manually to a value between 0.5 and- 1 W.
- m. This channel may also be used for public correspondence.
- n. This channel will be used for an automatic ship identification and surveillance system (AIS) capable of providing worldwide operating on seas and Inland Waterways.
- o. The availability of this channel is on a voluntary basis. All existing equipment shall be capable to of operating on this channel within a ten-year period after the entry into force of this Arrangement.
- p. After permission of the competent authority, this channel may be used only for special events on a temporary basis.
- q. In the Czech Republic this channel is used for service category nautical information.
- r. In the Czech Republic this channel is used for service category ship-to-port authorities.

Special Channels²

CH	SEND (MHz)	RECEIVE (MHz)	TRAFFIC TYPE	SHIP TO SHIP	SHIP TO SHORE	NAME TAG
CO ¹	156.000	156.000	UK Coast Guard Users	Yes	Yes	UK COAST GRD
M1	157.850	157.850	UK Marina Channel M1	Yes	Yes	UK MARINA
M2	161.425	161.425	UK Marina Channel M2	Yes	Yes	UK MARINA
31	157.550	162.150	INT'L, Duplex (Holland)	No	Yes	NL MARINA
96H	162.425	162.425	INT'L (Belgium)	No	Yes	BEL G MARINA
L1	155.500	155.500	INT'L (Skandinavia)	Yes	No	LEISURE 1
L2	155.525	155.525	INT'L (Skandinavia)	Yes	No	LEISURE 2
L3	155.650	155.650	INT'L (Skandinavia— not in Denmark)	Yes	No	LE ISURE3
F1	155.625	155.625	INT'L (Skandinavia)	Yes	No	FISHING 1
F2	155.775	155.775	INT'L (Skandinavia)	Yes	No	FISHING 2
F3	155.825	155.825	INT'L (Skandinavia) call back	Yes	No	FISHING 3
AIS1	161.975	161.975	AIS1	-----	-----	-----
AIS2	162.025	162.025	AIS2	-----	-----	-----

Note:

1. Lightly Shaded Simplex channel CH00 is only available in the UK to Coast Guard users with written authorization.
2. The special channels above maybe fitted to your radio. These are only licensed for use in the country indicated. No attempt should be made to use them in any other country.

Navico Full Two-Year Lowrance VHF Warranty

"We," "our," or "us" refers to NAVICO, the manufacturer of this Lowrance VHF product. "You" or "your" refers to the first person who purchases this product as a consumer item for personal, family or household use.

We warrant this product against defects or malfunctions in materials and workmanship, and against failure to conform to this product's written specifications, all for two (2) years from the date of original purchase by you. Battery Packs and accessory items have a one (1) year warranty. WE MAKE NO OTHER EXPRESS WARRANTY OR REPRESENTATION OF ANY KIND WHATSOEVER CONCERNING THIS PRODUCT. Your remedies under this warranty will be available so long as you can show in a reasonable manner that any defect or malfunction in materials or workmanship, or any non-conformity with the product's written specifications, occurred within two years from the date of your original purchase, which must be substantiated by a dated sales receipt or sales slip. Any such defect, malfunction, or non-conformity which occurs within two years from your original purchase date will either be repaired without charge or be replaced with a new product identical or reasonably equivalent to this product, at our option, within a reasonable time after our receipt of the product. If such defect, malfunction, or non-conformity remains after a reasonable number of attempts to repair by us, you may elect to obtain without charge a replacement of the product or a refund for the product. THIS REPAIR, OR REPLACEMENT OR REFUND (AS JUST DESCRIBED) IS THE EXCLUSIVE REMEDY AVAILABLE TO YOU AGAINST US FOR ANY DEFECT, MALFUNCTION, OR NON-CONFORMITY CONCERNING THE PRODUCT OR FOR ANY LOSS OR DAMAGE RESULTING FROM ANY OTHER CAUSE WHATSOEVER. WE WILL NOT UNDER ANY CIRCUMSTANCES BE LIABLE TO ANYONE FOR ANY SPECIAL, CONSEQUENTIAL, INCIDENTAL, OR OTHER INDIRECT DAMAGE OF ANY KIND.

Some states do not allow the exclusion or limitation of incidental or consequential damages, so the above limitations or exclusions may not apply to you.

This warranty does NOT apply in the following circumstances: (1) when the product has been serviced or repaired by anyone other than us; (2) when the product has been connected, installed, combined, altered, adjusted, or handled in a manner other than according to the instructions furnished with the product; (3) when any serial number has been effaced, altered, or removed; or (4) when any defect, problem, loss, or damage has resulted from any accident, misuse, negligence, or carelessness, or from any failure to provide reasonable and necessary maintenance in accordance with the instructions of the owner's manual for the product.

We reserve the right to make changes or improvements in our products from time to time without incurring the obligation to install such improvements or changes on equipment or items previously manufactured.

This warranty gives you specific legal rights and you may also have other rights which may vary from state to state.

REMINDER: You must retain the sales slip or sales receipt proving the date of your original purchase in case warranty service is ever required.

NAVICO, 12000 E. SKELLY DRIVE, TULSA, OK 74128, (800) 324-1356

How to Obtain Service

In the USA

We back your investment in quality products with quick, expert service and genuine Lowrance replacement parts. If you're in the United States and you have technical, return or repair questions, please contact the Factory Customer Service Department. Before any product can be returned, you must call customer service to determine if a return is necessary. Many times, customer service can resolve your problem over the phone without sending your product to the factory. To call us, use the following toll-free number:

800-324-1356

8 a.m. to 5 p.m. Central Standard Time, M-F

Lowrance Electronics may find it necessary to change or end our shipping policies, regulations, and special offers at any time. We reserve the right to do so without notice.

In Canada

If you're in Canada and you have technical, return or repair questions, please contact the Factory Customer Service Department. Before any product can be returned, you must call customer service to determine if a return is necessary. Many times, customer service can resolve your problem over the phone without sending your product to the factory. To call us, use the following toll-free number:

800-661-3983

905-629-1614 (not toll-free)

8 a.m. to 5 p.m. Eastern Standard Time, M-F

Outside Canada and the USA

If you have technical, return or repair questions, contact the dealer in the country where you purchased your unit. To locate a Lowrance dealer near you, visit our web site or consult your telephone directory for listings.

www.lowrance.com

Accessory Ordering Information for all countries

To order Lowrance accessories, please contact:

1. Your local marine dealer or consumer electronics store. Most quality dealers that handle marine electronic equipment or other consumer electronics should be able to assist you with these items.

To locate an Lowrance dealer near you visit our web site or consult your telephone directory for listings.

2. US customers: LEI Extras Inc., PO Box 129, Catoosa, OK 74015-0129
Call 1-800-324-0045 or visit our web site www.lei-extras.com.
3. Canadian customers can write:
Lowrance/Eagle Canada, 919 Matheson Blvd. E. Mississauga, Ontario L4W2R7 or
fax 905-629-3118.

Shipping Information

If it becomes necessary to send a product for repair or replacement, you must first receive a return authorization number from Customer Service. Products shipped without a return authorization will not be accepted. When shipping, we commend you do the following:

1. Please do not ship the knobs or mounting bracket with your unit.
2. If you are sending a check for repair, please place your check in an envelope and tape it to the unit.
3. For proper testing, include a brief note with the product describing the problem. Be sure to include your name, return shipping address and a day time telephone number. An e-mail address is optional but useful.
4. Pack the unit in a suitable size box with packing material to prevent any damage during shipping.
5. Write the Return Authorization (RA) number on the outside of the box underneath your return address.
6. For your security, you may want to insure the package through your shipping courier. Lowrance does not assume responsibility for goods lost or damaged in transit.

LOWRANCE®

Lowrance Pub. 988-0158-101

Printed in China - 042008

Copyright © 2008

All Rights Reserved

Navico

MN000799A-G



Industry
Canada

Industrie
Canada

