



## INSTALLATION INSTRUCTIONS FOR PART 99-7013

### APPLICATIONS

# Mitsubishi Outlander

## 2007-2010

# 99-7013



#### KIT FEATURES

- DIN Radio Provision with Pocket
- ISO Mount Radio Provision with Pocket
- Double DIN Radio Provision
- Stacked ISO Mount Units Provision

#### KIT COMPONENTS

- A) Radio Housing • B) ISO Brackets • C) ISO Trim Plate • D) Double DIN Brackets  
• E) Double DIN Trim Plate • F) Snap In Pocket

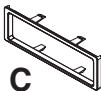
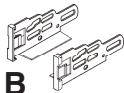
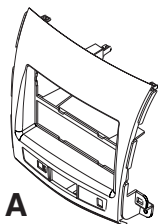

Harness & Antenna Connections (sold separately)

70-7005 - Mitsubishi Harness 07-up



#### TOOLS REQUIRED:

- Small Flat Blade Screwdriver/ Panel Removal Tool  
• Phillips Screwdriver • Socket Set



1-800-221-0932



[www.metraonline.com](http://www.metraonline.com)

© COPYRIGHT 2007-2010 METRA ELECTRONICS CORPORATION



**TABLE OF CONTENTS**

**Dash Disassembly**

**- Mitsubishi Outlander 2007-2010. . . . . 1,2**

**Kit Preparation . . . . . 3**

**Kit Assembly**

**- DIN Radio Provision with Pocket . . . . . 4**

**- ISO Mount Radio Provision with Pocket . . . . . 5**

**- Double DIN/Stacked ISO Units Provision . . . . . 6**

**Final Assembly . . . . . 7**

**\*Note:**

**Refer also to the instructions included with the aftermarket radio.**

**MITSUBISHI OUTLANDER 2007-2010**

- 1** Disconnect the negative battery terminal to prevent an accidental short circuit.
- 2** Unclip and remove the vents from the left and right side of the factory radio panel. (Figure A)
- 3** Remove (2) Phillips screws securing the radio trim panel then unclip and remove the panel. (Figure B)
- 4** Remove (4) Phillips screws securing the radio chassis. Unplug and remove the chassis. (Figure C)

*Continued on page 2.*

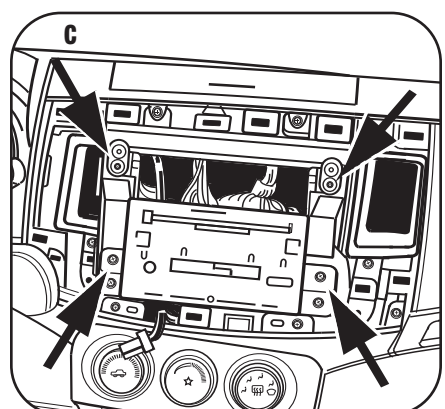
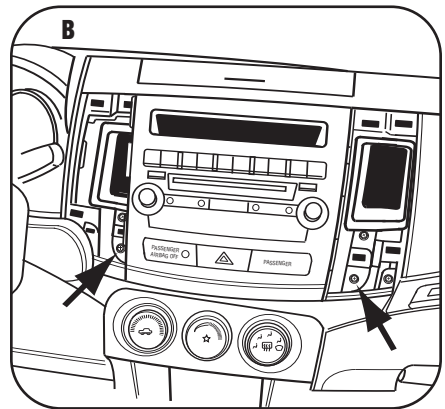
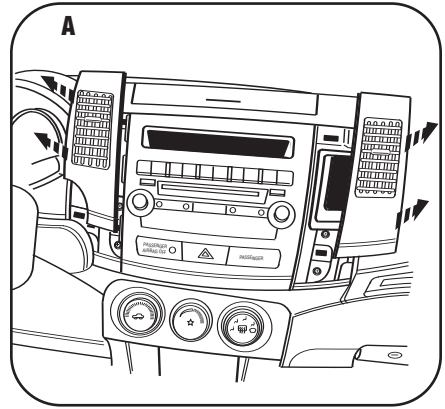

**MITSUBISHI OUTLANDER 2007-2010**

**5** Remove (7) Phillips screws securing the hazard switch assembly to the back of the factory radio trim panel. Unplug the ribbon cable from the hazard switch assembly and remove assembly from panel from rear. (Retain the screws and switch assembly to be reused during kit preparation) (Figure D,E)

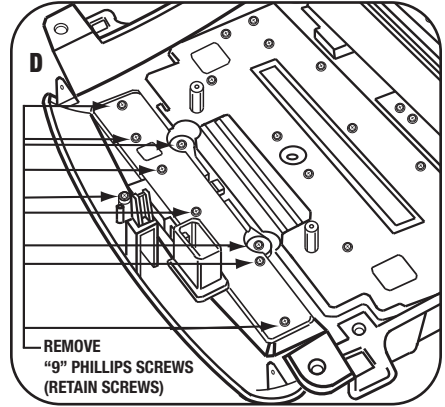

**6** Remove the labels from the front of the radio trim panel at each side of the hazard switch by pushing them out from behind the panel. (Retain the labels to be reused during kit preparation) (Figure F)

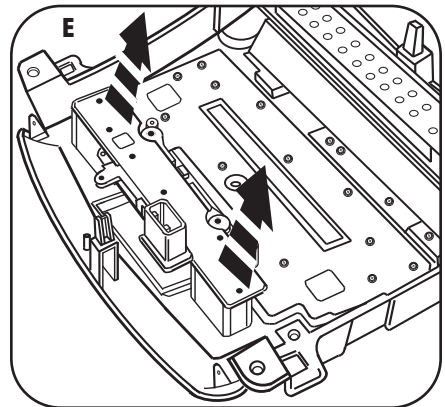

*Continued to kit preparation.*

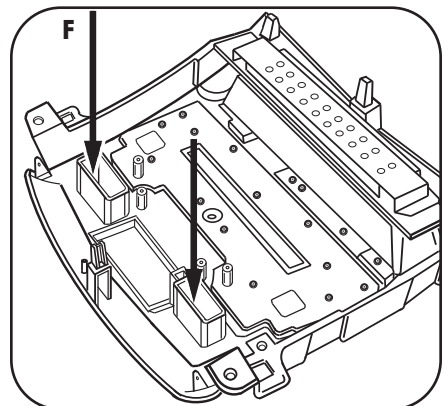

## MITSUBISHI OUTLANDER 2007-2010

- 5 Secure the hazard switch panel into the radio housing using the factory hardware removed previously and apply labels from the front of the factory radio trim panel to front of the Metra radio panel. (Figure A,B)

*Continue to kit assembly.*

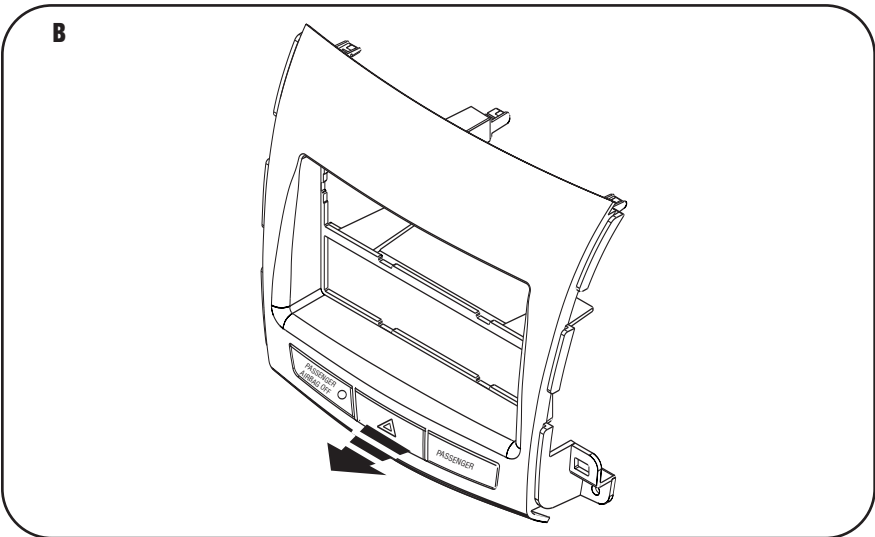
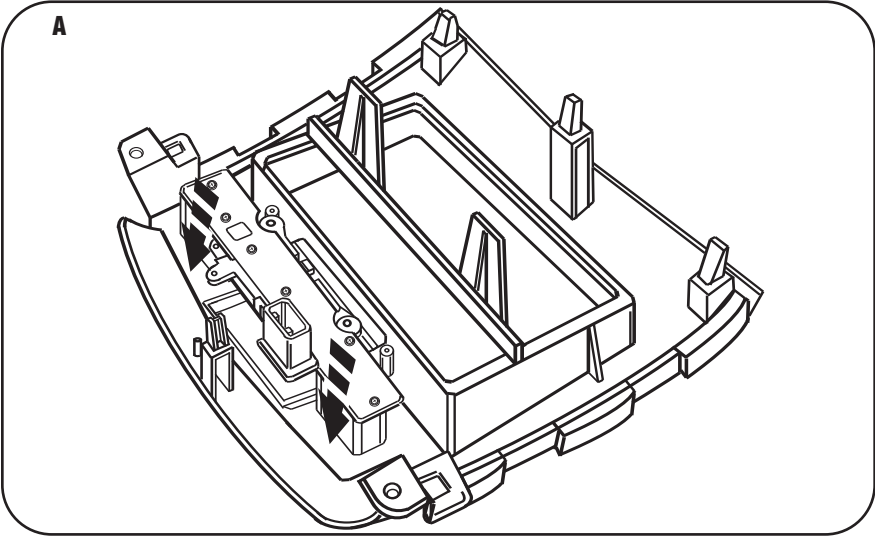

## DIN RADIO PROVISION WITH POCKET

*\*Note: Refer also to the instructions included with the aftermarket radio.*

- 1 Slide the DIN cage into the Radio Housing and secure by bending the metal locking tabs outward. (Figure A)
- 2 Slide the aftermarket radio into the cage until it snaps into place. (Figure B)
- 3 Snap the pocket into the radio housing. (Figure C)

*Continue to final assembly.*

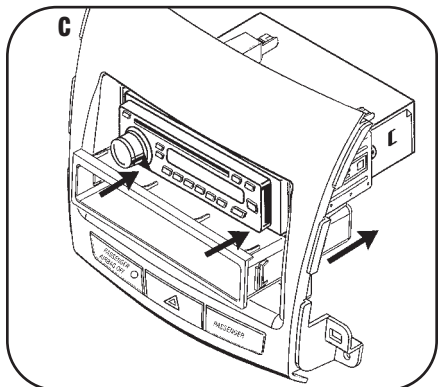
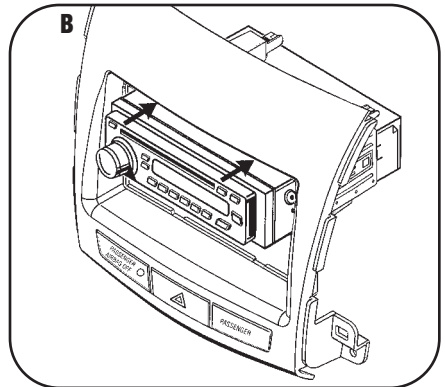
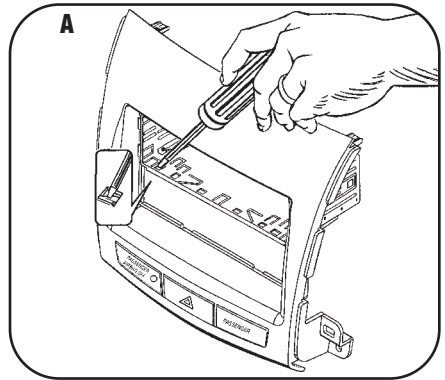

## ISO MOUNT RADIO PROVISION WITH POCKET

*\*Note: Refer also to the instructions included with the aftermarket radio.*

- 1 Mount the ISO Brackets to the aftermarket radio using the screws supplied with the radio. (Figure A)
- 2 Slide the radio into the Radio Housing until it snaps into place. (Figure B)
- 3 Snap the Trim Plate onto the front of the Radio Housing. (Figure C)
- 4 Snap the pocket into the Radio Housing. (Figure D)

*Continue to final assembly.*

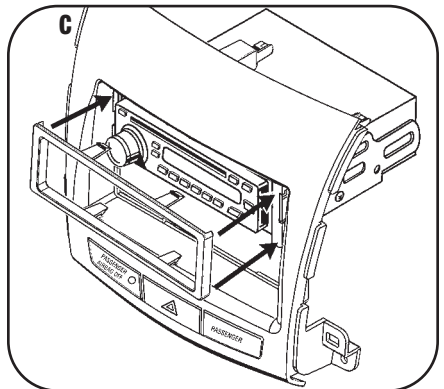
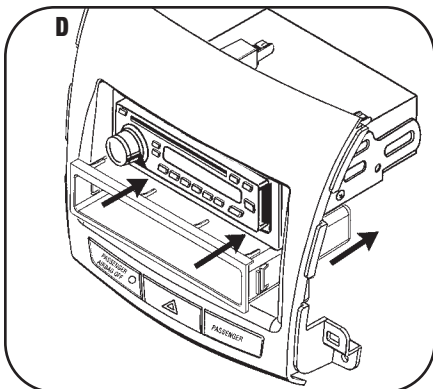
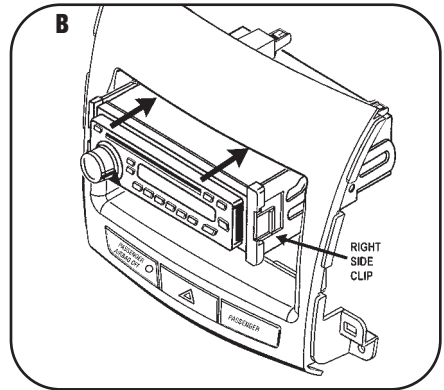
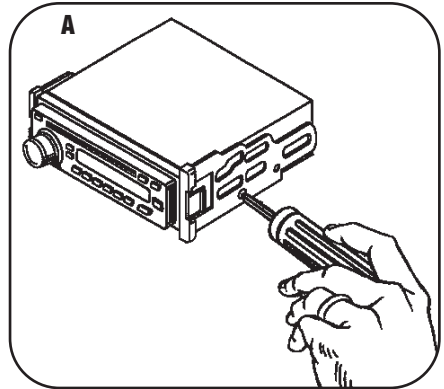

## DOUBLE DIN/STACKED ISO UNITS PROVISION

*\*Note: Refer also to the instructions included with the aftermarket radio.*

- 1 Cut and remove the center bar from the Radio Housing. (Figure A)
- 2 Snap the Double DIN Brackets to the inside edge of the Radio Housing. (Figure B)
- 3 Slide the Double DIN or stacked ISO unit(s) into the bracket/radio housing assembly and secure the Double DIN or stacked ISO unit(s) to the assembly using the screws supplied with the unit(s). (Figure C)
- 4 Snap the Double DIN Trim Plate onto the front of the Radio Housing. (Figure C)

*Continue to final assembly.*

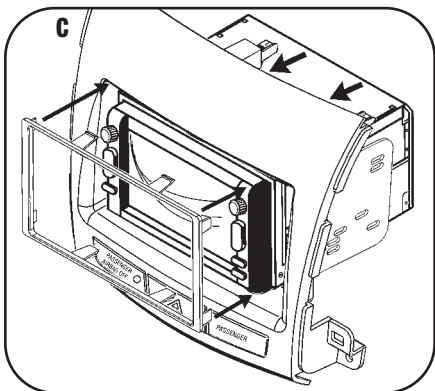
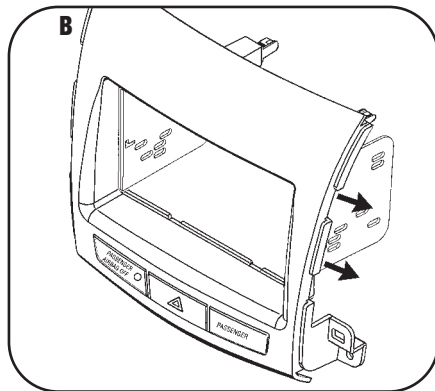
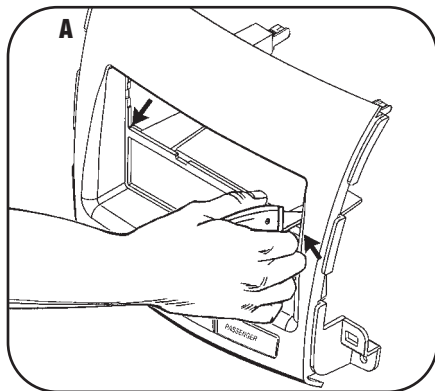



# FINAL ASSEMBLY

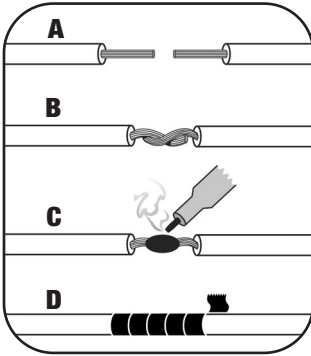

- (A) Strip wire ends back 1/2"**
- B) Twist ends together**
- C) Solder**
- D) Tape**

- 1** Locate the factory wiring harness in the dash. Metra recommends using the proper mating adapter and making connections as shown. (Isolate and individually tape off the ends of any unused wires to prevent electrical short circuit.)
- 2** Re-connect the negative battery terminal and test the unit for proper operation.
- 3** Reassemble radio and dash assemblies in reverse order of disassembly.

## FINAL WIRING CONNECTIONS

Make wiring connections using the EIA color code chart shown below and the instructions included with the head unit. Metra recommends making connections as shown below; Strip, Splice, Solder, Tape. Isolate and individually tape off ends of any unused wires to prevent electrical short circuit.

### METRA / EIA WIRING CODE

12V Ignition / Acc. . . . . Red	Right Front (+) . . . . . Gray
12V Batt / Memory. . . . . Yellow	Right Front (-). . . . . Gray/ Black
Ground. . . . . Black*	Left Front (+) . . . . . White
Power Antenna . . . . . Blue	Left Front (-). . . . . White / Black
Amp Turn-On . . . . . Blue / White	Right Rear (+) . . . . . Violet
Amp Ground. . . . . Black / White	Right Rear (-). . . . . Violet / Black
Illumination . . . . . Orange	Left Rear (+) . . . . . Green
Dimmer . . . . . Orange / White	Left Rear (-). . . . . Green / Black

**\*NOTE:** When a Black wire is not present, ground radio to vehicle chassis.  
All colors may not be present on all leads due to manufacturer's specifications.





# 99-7013 INSTRUCTIONS



**1-800-221-0932**



**[www.metraonline.com](http://www.metraonline.com)**

REV. 04/21/10 © COPYRIGHT 2007-2010 METRA ELECTRONICS CORPORATION INST99-7013