



INSTALLATION INSTRUCTIONS FOR PART 99-5822B

APPLICATIONS

**2009-10 FORD F-150
LARIAT / KING RANCH / PLATINUM MODELS
(Not for NAV Equipped Models)**

99-5822B - BLACK

**99-5822AS - PLATINUM / ASH SATIN
99-5822CM - KING RANCH / CURLY MAPLE
99-5822MM - LARIAT / MILANO MAPLE**



KIT FEATURES

- DIN Radio Provision With Pocket
- ISO Mount Radio Provision With Pocket
- Painted or Wood Grain

KIT COMPONENTS

- A) Radio Housing • B) Radio Housing Brackets • C) Radio Housing Trim Panel
- D) ISO Brackets • E) ISO Trim Plate • F) (6) U Style Panel Clips

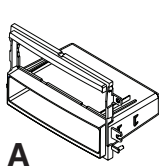

A



B

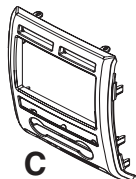

C

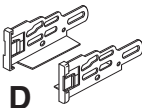

D

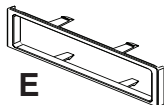

E

**WIRING AND ANTENNA CONNECTIONS
(Sold Separately)**

Harness:

- Please see www.metraonline.com for specific interface harness

Antenna Adapter:

- 40-CR10 - Chrysler antenna adapter 02-up



F

TOOLS REQUIRED:

- Cutting Tool • Phillips Screwdriver • Socket Wrench • Torx Driver
- Panel Removal Tool

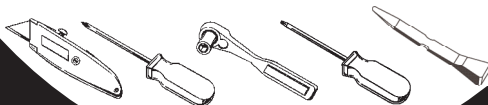

1-800-221-0932



www.metraonline.com

© COPYRIGHT 2010 METRA ELECTRONICS CORPORATION



TABLE OF CONTENTS

Dash Disassembly

- FORD F-150 2009-10 1,2

Kit Preparation

- FORD F-150 2009-10..... 3

Kit Assembly

- DIN Radio Provision With Pocket 4

- ISO Mount Radio Provision With Pocket 5

Final Assembly 6

***Note:**

Refer also to the instructions included with the aftermarket radio.



KNOWLEDGE IS POWER

Enhance your installation and fabrication skills by enrolling in the most recognized and respected mobile electronics school in our industry. Log onto www.installerinstitute.com or call 800-354-6782 for more information and take steps toward a better tomorrow.

FORD F-150 2009-10

- 1 Disconnect the negative battery terminal to prevent an accidental short circuit.
- 2 Unclip and remove the switch panel to the right of the cigarette lighter then remove the (1) 9/32" screw exposed. (Figure A)
- 3 Remove the rubber pad at the top of the radio trim panel then remove the (2) 9/32" screws exposed. (Figure B)
- 4 Unclip and pull the side panels containing the a/c vents away from the radio trim panel. **Note: It is not necessary to remove the panels completely.** (Figure C)
- 5 Unclip and remove the radio trim panel. (Figure D)

Continued on page 2.

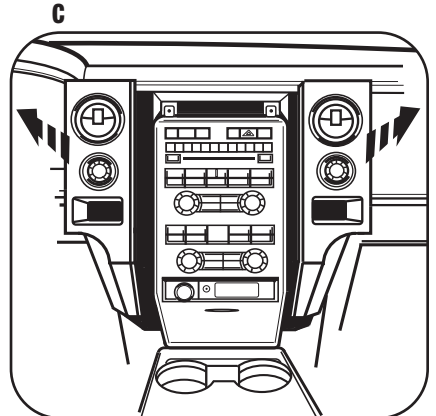
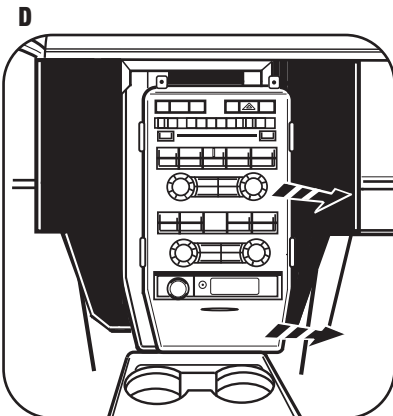
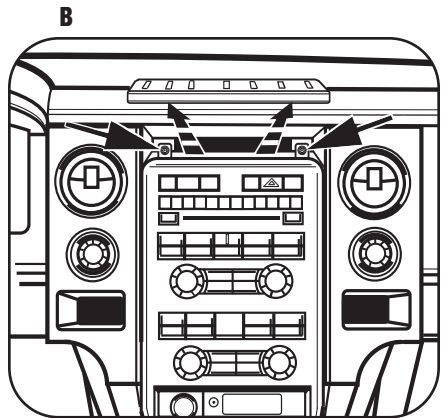
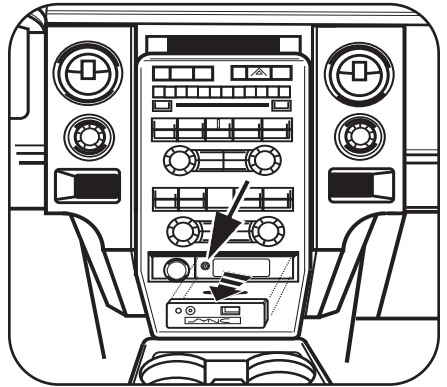

FORD F-150 2009-10

- 6** Unclip and remove the hazard/airbag switch and driver info switch assemblies from the factory radio trim panel. (Figure E)
- 7** Unclip and remove the cigarette lighter socket from the radio trim panel. (Figure F)
- 8** Remove (4) Torx screws securing the factory climate control to the radio trim panel. (Figure G)
- 9** Remove (4) 9/32" screws to remove the factory radio.

Continue to kit preparation.

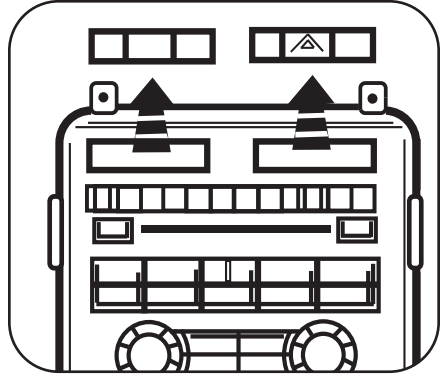
E

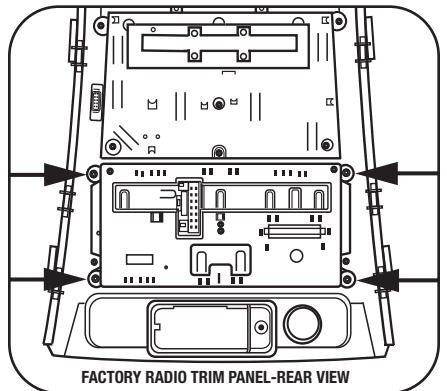
F

G

FORD F-150 2009-10

- 1 Clip the hazard/airbag switch and driver info switch assemblies into the radio housing in the same location as the factory radio trim panel. (Figure A)
- 2 Clip the cigarette lighter socket into the radio housing in the same location as the factory radio trim panel. (Figure B)
- 3 Secure the climate control into the radio housing using the factory hardware in the same location as the factory radio trim panel. (Figure C)
- 4 Attach the (6) U style panel clips to the radio housing in the same location as the factory radio trim panel. (Figure D)

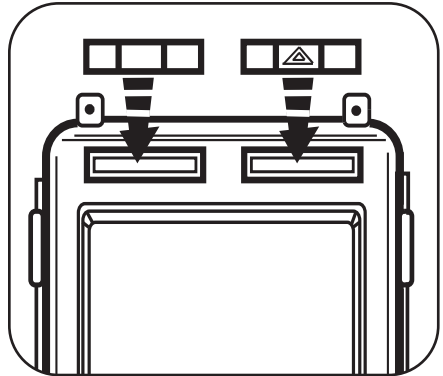
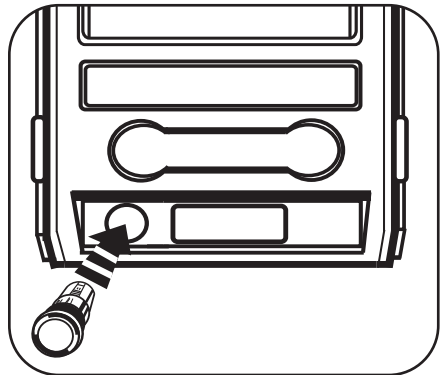
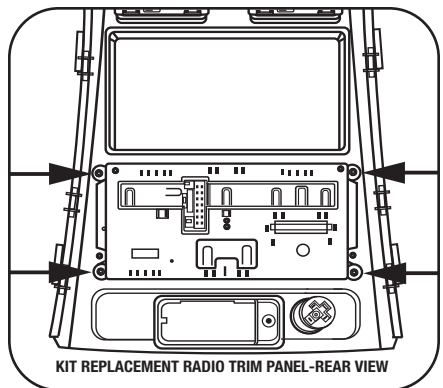
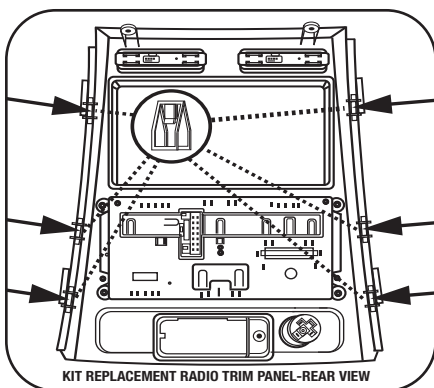
Continue to kit assembly.

A

B

C

D

KIT REPLACEMENT RADIO TRIM PANEL-REAR VIEW

KIT REPLACEMENT RADIO TRIM PANEL-REAR VIEW

DIN RADIO PROVISION WITH POCKET

**Note: Refer also to the instructions included with the aftermarket radio.*

- 1 Cut and remove the top (2) mounting holes off of the radio housing.
Note: The notch in the housing should be on top. (Figure A)
- 2 Slide the included brackets onto the sides of the radio housings pocket from the back of the housing forward. (Figure B)
- 3 Slide the DIN cage into the Radio Housing and secure by bending the metal locking tabs down. (Figure C)
- 4 Slide the aftermarket head unit into the cage and secure. (Figure D)

Continue to final assembly.

A

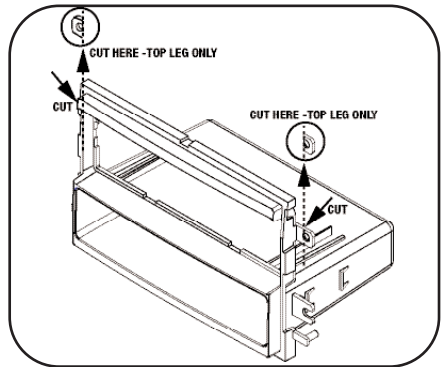

B

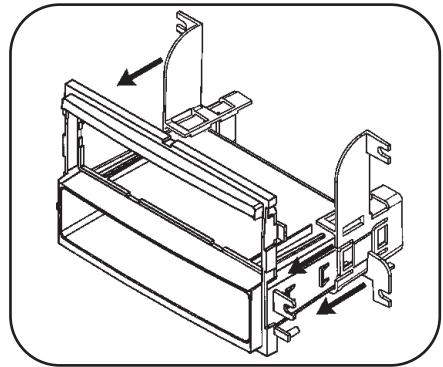

C

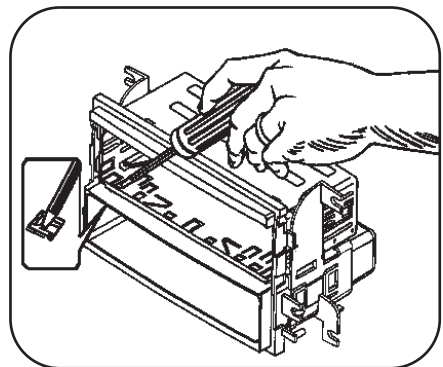

D

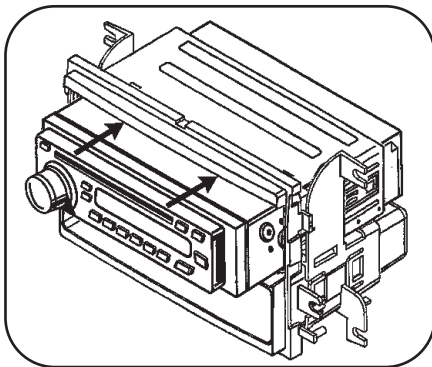

ISO MOUNT RADIO PROVISION WITH POCKET

**Note: Refer also to the instructions included with the aftermarket radio.*

- 1 Cut and remove the top (2) mounting holes off of the radio housing.

Note: *The notch in the housing should be on top.* (Figure A)

- 2 Slide the included brackets onto the sides of the radio housings pocket from the back of the housing forward. (Figure B)

- 3 Mount the ISO Brackets to the head unit with the screws supplied with the unit. (Figure C)

- 4 Slide the head unit into the radio opening until the side clips engage. (Figure D)

- 5 Snap the trim plate into the Radio Housing. (Figure D)

Continue to final assembly.

A

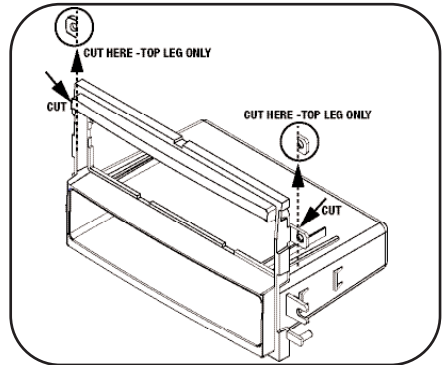

B

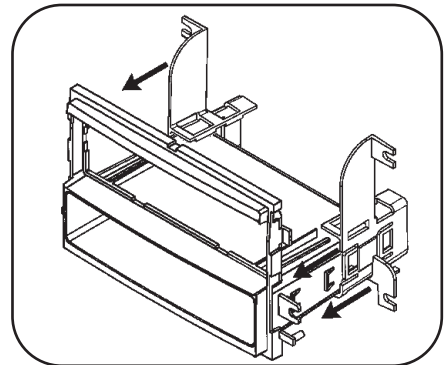

C

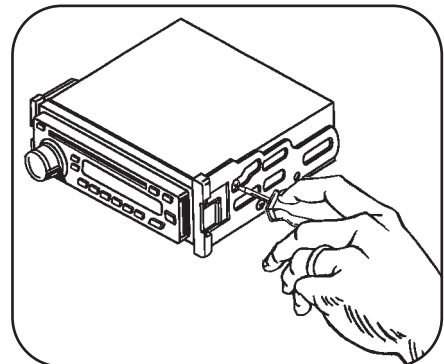

D

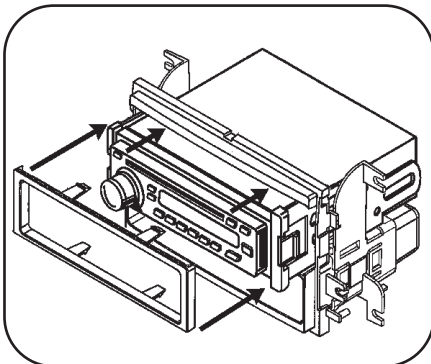

FINAL ASSEMBLY

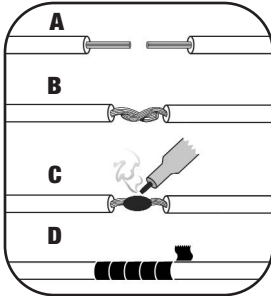

(A) Strip wire ends back 1/2"

B) Twist ends together

C) Solder

D) Tape

- 1 Locate the factory wiring harness in the dash. Metra recommends using the proper mating adapter and making the connections as shown. (Isolate and individually tape off the ends of any unused wires to prevent electrical short circuit).
- 2 Re-connect the negative battery terminal and test the unit for proper operation.
- 3 Reassemble radio and dash assemblies in reverse order of disassembly using the 99-5822B radio housing in place of the factory radio trim panel.

FINAL WIRING CONNECTIONS

Make wiring connections using the EIA color code chart shown below and the instructions included with the head unit. Metra recommends making connections shown below; Strip, Splice, Solder, Tape. Isolate and individually tape off ends of any unused wires to prevent electrical short circuit.

METRA / EIA WIRING CODE

12V Ignition / Acc. Red	Right Front (+) Gray
12V Batt / Memory. Yellow	Right Front (-). Gray/ Black
Ground. Black*	Left Front (+) White
Power Antenna. Blue	Left Front (-). White / Black
Amp Turn-On Blue / White	Right Rear (+) Violet
Amp Ground. Black / White	Right Rear (-). Violet / Black
Illumination Orange	Left Rear (+) Green
Dimmer Orange / White	Left Rear (-). Green / Black

***NOTE: When a Black wire is not present, ground radio to vehicle chassis. All colors may not be present on all leads due to manufacturer's specifications.**



1-800-221-0932



www.metraonline.com

REV. 05/21/10 © COPYRIGHT 2010 METRA ELECTRONICS CORPORATION INST99-5822B