

*Lanzar* **Opti**

AMERICAN CRAFTED PERFORMANCE



OPTI 500x2

OPTI 200x4

Owner's Manual **Opti**

<b>INTRODUCTION &amp; FEATURES</b> .....	<b>1</b>
<b>FEATURES &amp; CONTROLS</b> .....	<b>2~3</b>
2 Channel(OPTI 500x2) .....	<b>2</b>
4 Channel(OPTI 200x4) .....	<b>3</b>
<b>SPECIFICATIONS</b> .....	<b>4</b>
<b>INSTALLATION &amp; PRECAUTIONS</b> .....	<b>5</b>
<b>SYSTEM WIRING</b> .....	<b>6~12</b>
2 Channel stereo configuration .....	<b>7</b>
2 Channel bridged mode configuration .....	<b>7</b>
2 Channel tri-mode configuration .....	<b>8</b>
Tri-amp system using three 2 Channel amplifiers .....	<b>9</b>
4 Channel stereo configuration .....	<b>10</b>
4 Channel bridged mode configuration .....	<b>11</b>
4 Channel tri-mode configuration .....	<b>12</b>
<b>TROUBLESHOOTING</b> .....	<b>13</b>
<b>WIRING</b> .....	<b>14</b>

*Lanzar*

# Opti

Congratulations on your purchase of a Lanza OPTI amplifier. You have purchased a quality product designed and engineered to give you many years of uncompromised musical service. OPTI amplifiers are designed with the latest technology available, incorporating a DC to DC Switching Power Supply, which provides headroom for even the most demanding peaks and dynamic ranges found on modern CD's and recordings.

## Features

- MOSFET switches maintain rated power over a wide range of battery voltages
- PWM(Pulse-Width-Modulated) System.
- 2 Ohm Stable Stereo operation
- Stereo, Bridge Mode and Tri-Mode System Application Compatible
- Variable input level controls for each pair of channels
- Variable high and low pass crossover controls
- Thermal and speaker short protection circuitry
- Power and Protection LED indicators
- Bass Boost Circuitry
- Nickel plated power, RCA and speaker connectors
- High-efficiency, heavy aluminum heatsink
- Bass Boost Remote control

## FEATURES AND CONTROLS OPTI 500x2

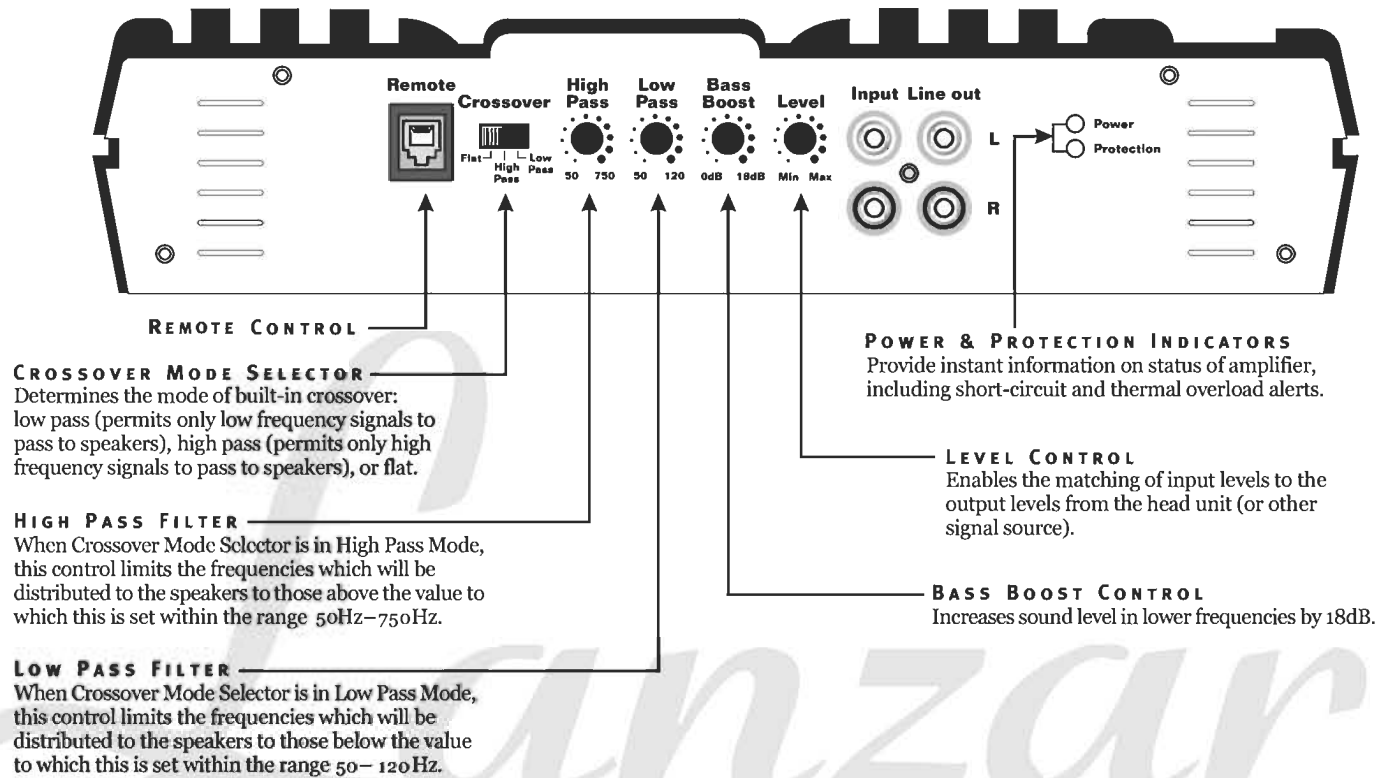

## FEATURES AND CONTROLS OPTI 200x4

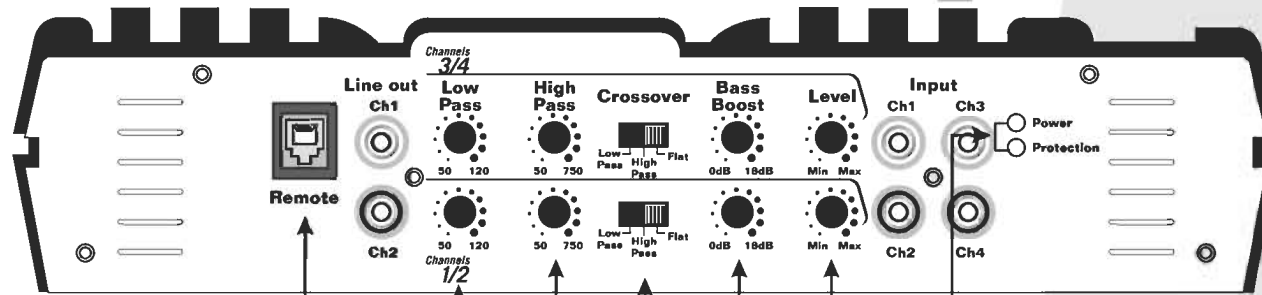

### REMOTE CONTROL

### LOW PASS FILTER

When Crossover Mode Selector is in Low Pass Mode, this control limits the frequencies which will be distributed to the speakers to those below the value to which this is set within the range 50–120 Hz.

### HIGH PASS FILTER

When Crossover Mode Selector is in High Pass Mode, this control limits the frequencies which will be distributed to the speakers to those above the value to which this is set within the range 50 Hz–750 Hz.

### CROSSOVER MODE SELECTOR

Determines the mode of built-in crossover: low pass (permits only low frequency signals to pass to speakers), high pass (permits only high frequency signals to pass to speakers), or flat.

### POWER & PROTECTION INDICATORS

Provide instant information on status of amplifier, including short-circuit and thermal overload alerts.

### LEVEL CONTROL

Enables the matching of input levels to the output levels from the head unit (or other signal source).

### BASS BOOST CONTROL

Increases sound level in lower frequencies by 18 dB.

## **SPECIFICATIONS**

<b>MODEL</b>	<b>OPTI 500x2</b>	<b>OPTI 200x4</b>
<b>RMS at 4 Ohms</b>	500W x 2	125W x 4
<b>MAX at 4 Ohms</b>	1000W x 2	400W x 4
<b>At 4 Ohms Bridged</b>	2000W x 1	800W x 2
<b>RMS at 2 Ohms</b>	750W x 2	200W x 4
<b>Min. Speaker Impedance</b>	2 Ohm	2 Ohm
<b>T.H.D</b>	0.04%	0.04%
<b>Frequency Response</b>	10Hz ~ 35kHz, -1dB	10Hz ~ 35kHz, -1dB
<b>Input Sensitivity</b>	200mV~8V	200mV~8V
<b>S/N Ratio</b>	>100dB	>100dB
<b>Channel Separation</b>	>60dB	>60dB
<b>Crossover (Low Pass Filter)</b>	50Hz~120Hz	50Hz~120Hz
<b>Crossover(High Pass Filter)</b>	50Hz~750Hz	50Hz~750Hz
<b>Bass Boost Control</b>	0 ~ +18dB	0 ~ +18dB
<b>Dimensions(inches)</b>	10.08" x 2.12" x 23.22"	10.08" x 2.12" x 16.73"
<b>Fuse(s)</b>	40A x 4	30A x 3

## **INSTALLATION**

---

1. Find a suitable location in the vehicle to mount the amplifier.
2. Make sure there is sufficient air flow around the intended mounting location.
3. Bolt the amplifier to the mounting surface.
4. Connect the power ground terminal to the nearest point on the chassis of the car. Keep this ground wire less than one meter (39") in length. Use 8 gauge wire.
5. Connect the remote terminal to the remote output of the head unit using 14 gauge wire.
6. Connect an empty fuse holder within 300 mm (12") of the battery and run 8 gauge or larger high quality cable from this fuse to the amplifier location.
7. Make sure there is no fuse in this fuse holder. Then make the connection to the "BATT" connection on the amplifier.
8. If multiple amplifiers are being used, use cables (each with its own fuse at the battery) or a #0 or #2 cable from the fuse holder at the battery to a distribution block at or near the amplifier's location.
9. Connect all line inputs and outputs using high-quality RCA-RCA cables.
10. Insert fuse(s) at the battery fuse holder(s).
11. Recheck all connections before powering up.
12. Set all level controls to their least sensitive positions and set all crossover controls, switches, etc. to the desired frequency or position.
13. Once the system is powered up, set the volume control on the head unit to about the 2 o'clock position, and then set all the amplifiers' level controls for maximum output level.
14. Further fine tuning of the various controls may be necessary to obtain the desired results.

## **Opti**

### **PRECAUTIONS**

- Before you drill or cut any holes, investigate your car's layout very carefully. Take care when you work near the gas tank, fuel lines, hydraulic lines and electrical wiring.
- Do not operate the amplifier when it is unmounted. Attach all audio system components securely within the automobile to prevent damage, especially in an accident.
- Do not mount this amplifier so that the wire connections are unprotected or in a pinched condition, or likely to be damaged by nearby objects. Be sure to select a location inside your vehicle which has adequate ventilation.
- Before making or breaking power connections in your system, disconnect the vehicle battery. Confirm that your head unit or other equipment is turned off while connecting the input jacks and speaker terminals.
- If you need to replace the power fuse, only replace it with a fuse identical to that supplied with the system. Using a fuse of a different type or rating may result in damage to your system which isn't covered by the manufacturer's warranty.

# SYSTEM WIRING

## 2 CHANNEL STEREO CONFIGURATION

OPTI 500x2

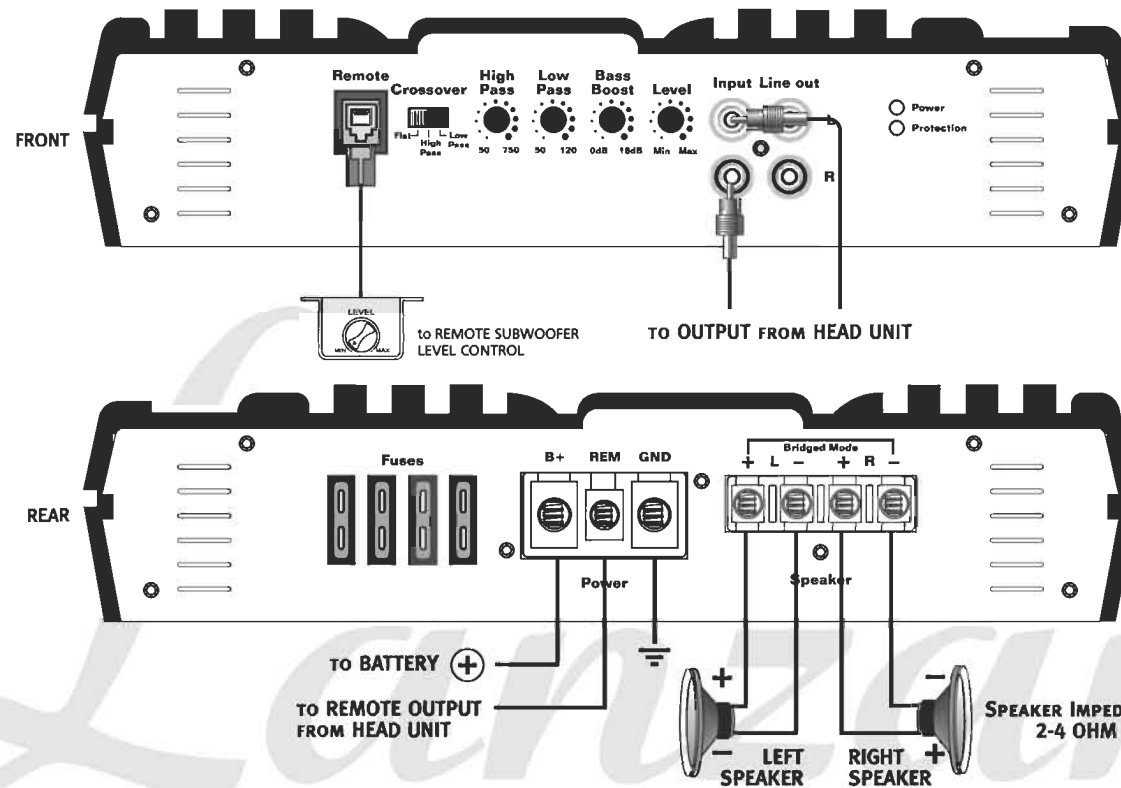



OPTI 500x2

## SYSTEM WIRING 2 CHANNEL BRIDGED MODE CONFIGURATION

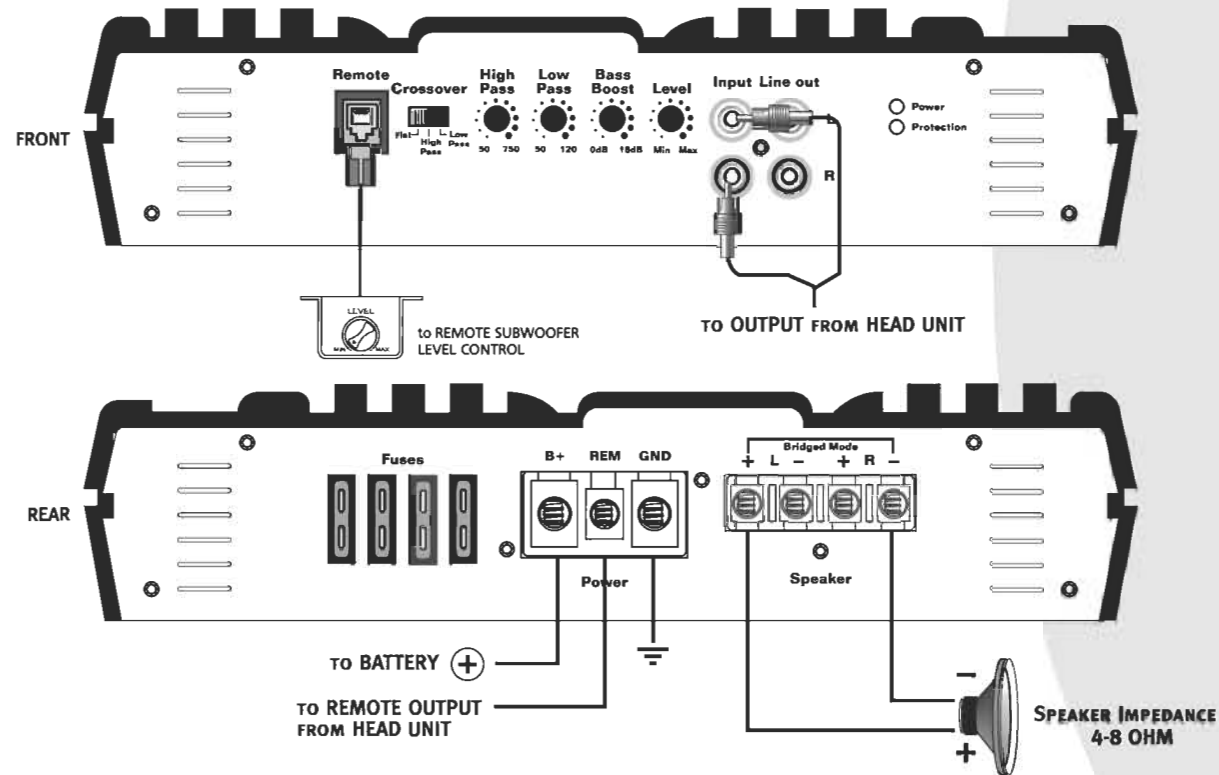

# SYSTEM WIRING

## 2 CHANNEL TRI-MODE CONFIGURATION

OPTI 500x2

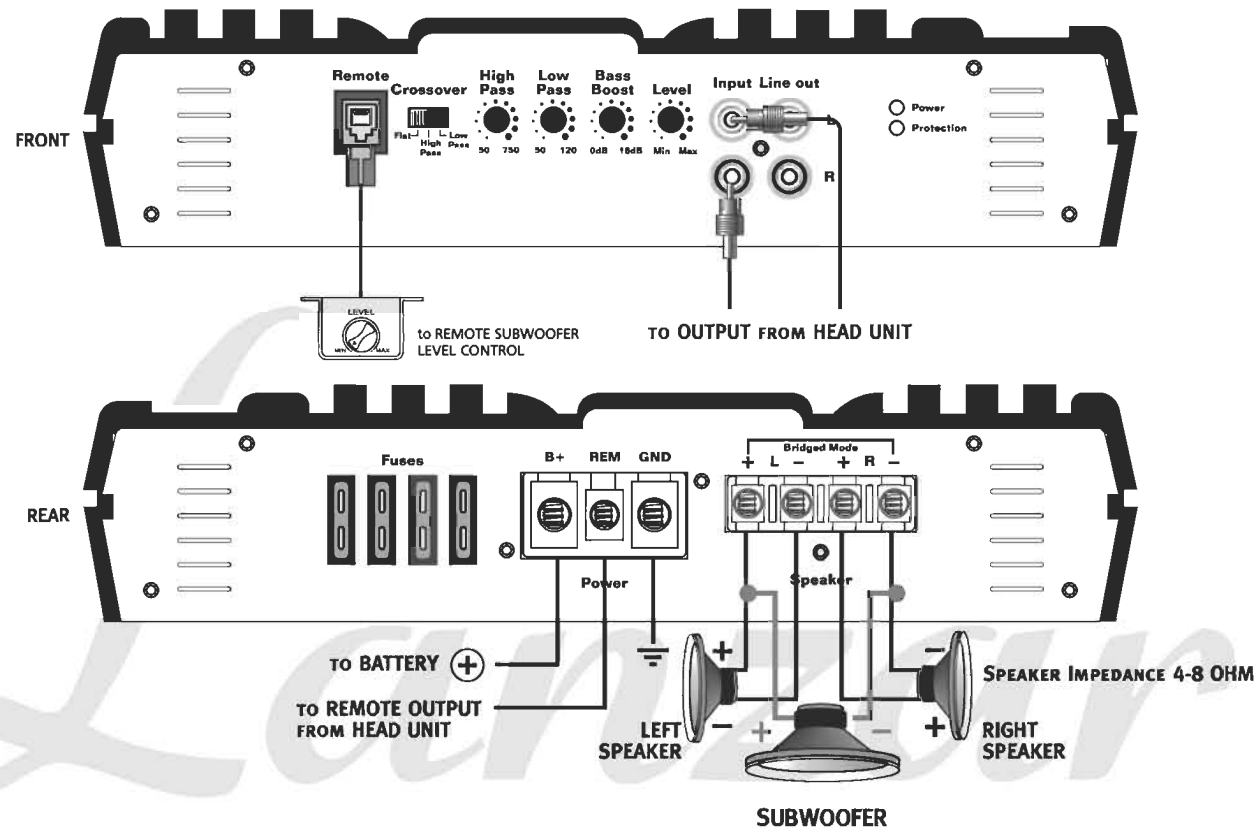

# OPTI 500x2

# SYSTEM WIRING TRIAMP SYSTEM USING THREE 2 CHANNEL AMPLIFIERS

## MASTER AMP FRONT (WOOFERS)

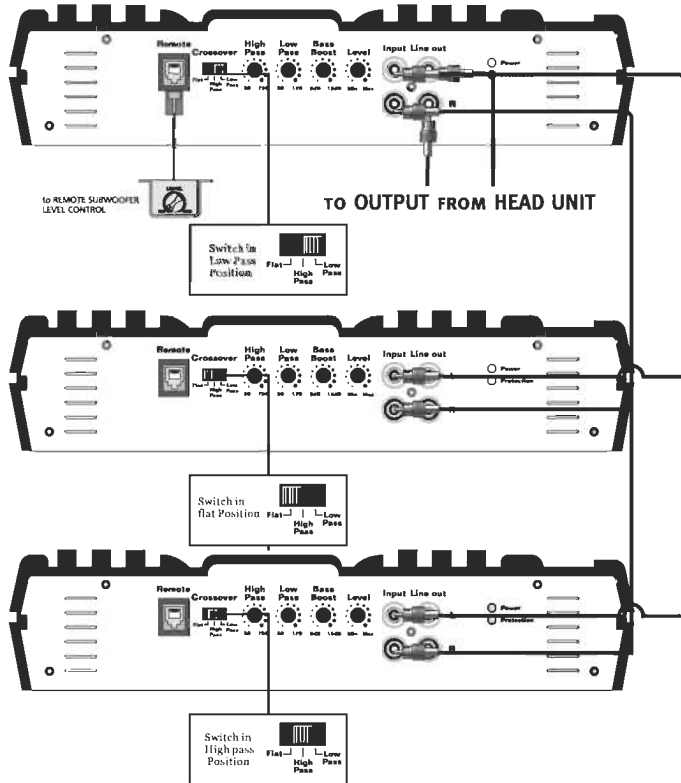

## MASTER AMP REAR

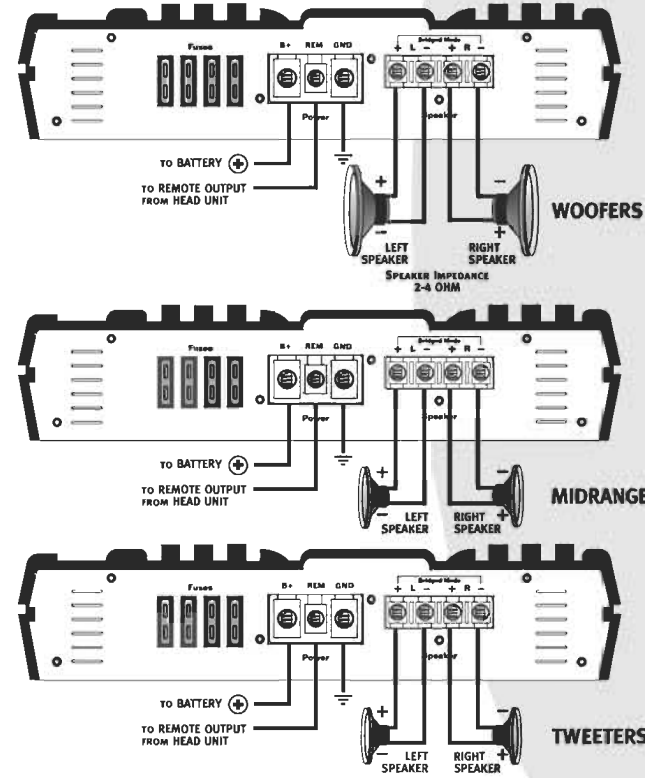

# SYSTEM WIRING

## 4 CHANNEL STEREO CONFIGURATION

OPTI 200x4

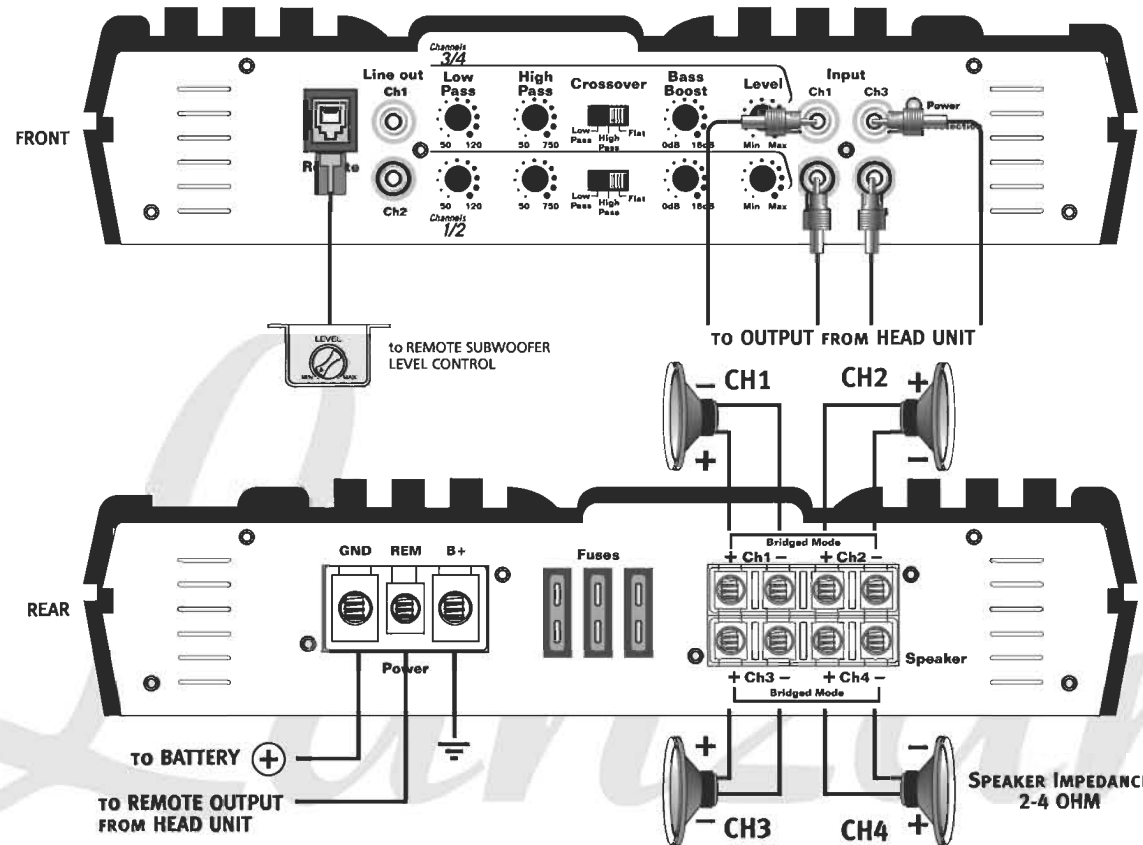

OPTI 200x4

# SYSTEM WIRING 4 CHANNEL BRIDGED MODE CONFIGURATION

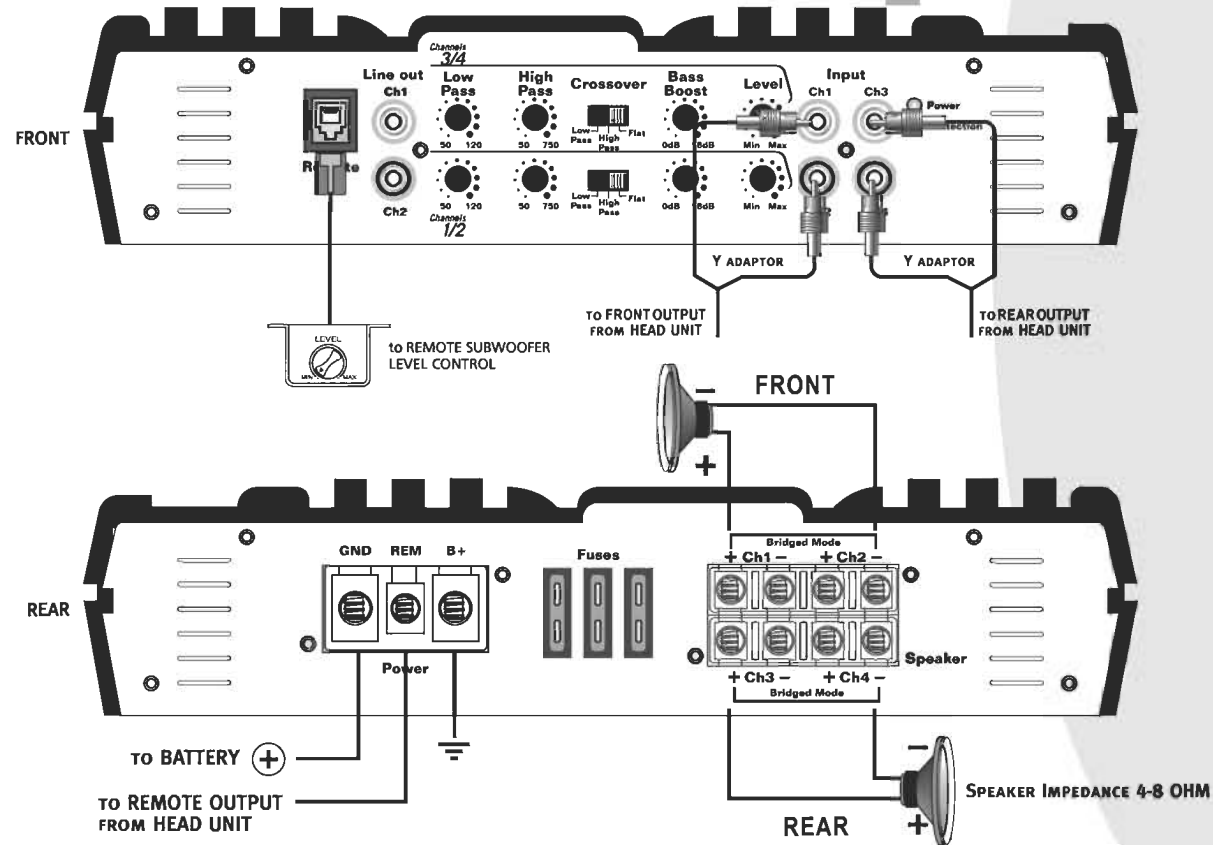

# SYSTEM WIRING

## 4 CHANNEL TRI-MODE CONFIGURATION

OPTI 200x4

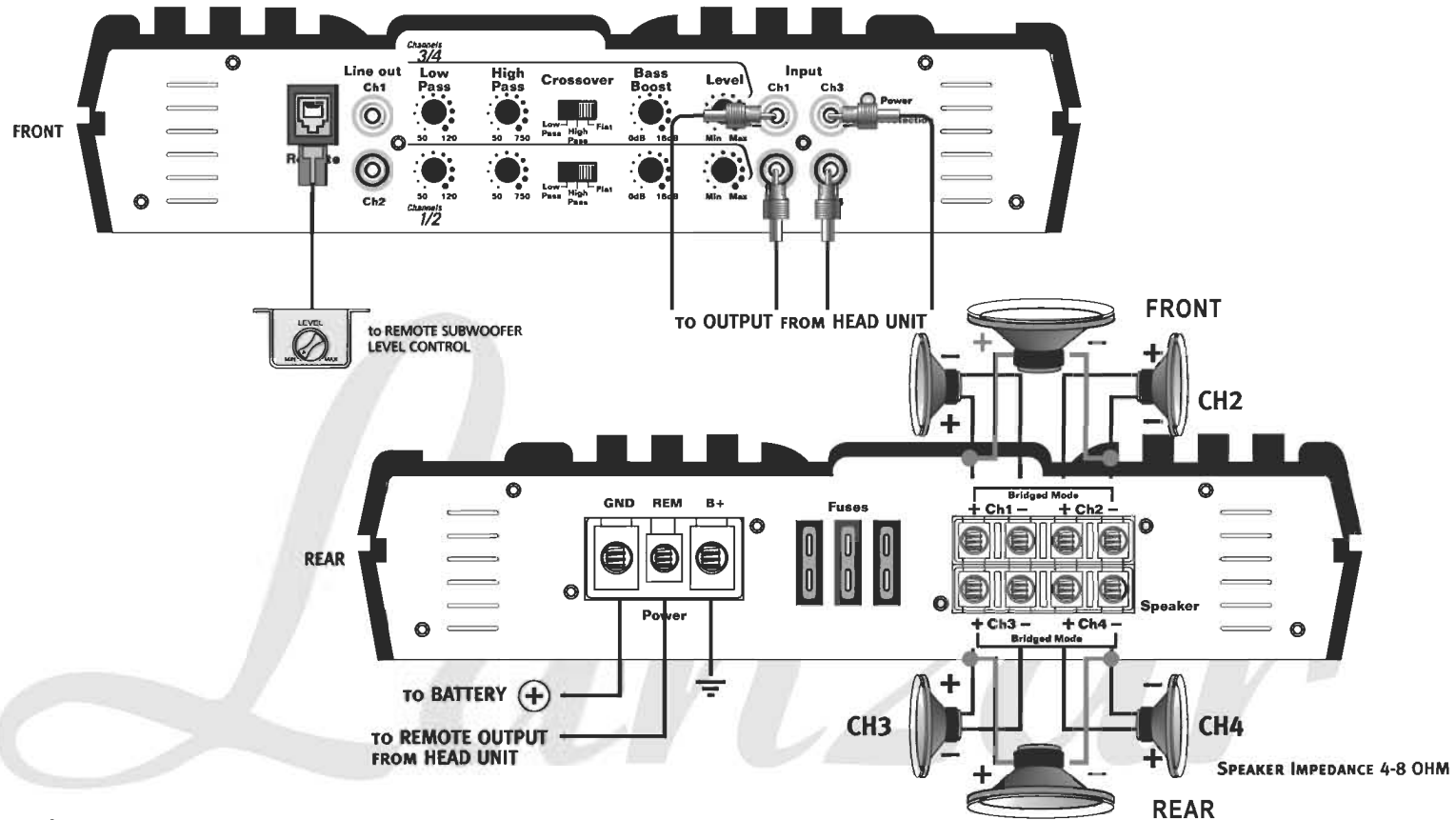

# OPTI

## TROUBLESHOOTING

### **AMPLIFIER WILL NOT POWER UP.**

- Check for good ground connection.
- Check that remote DC terminal has at least 3v DC.
- Check that there is battery power on the + terminal.
- Check all fuses.
- Check that Protection LED is not lit. If it is lit, shut off amplifier briefly and then repower it.

### **HIGH HISS OR ENGINE NOISE (ALTERNATOR WHINE) IN SPEAKERS.**

- Disconnect all RCA inputs to the amplifier(s) – if hiss/noise disappears, then plug in the component driving the amplifier and unplug its inputs. If hiss/noise disappears, go on until the faulty/noisy component is found.
- It is best to set the amplifier's input level as low as possible. The best subjective S/N ratio is obtainable this way. Try to drive as high a signal level from the head unit as possible.

### **PROTECTION LED COMES ON WHEN THE AMPLIFIER IS POWERED UP.**

- Check for shorts on speaker leads.
- Check that the volume control on the head unit is turned down low.
- Remove speaker leads, and reset the amplifier. If the Protection LED still comes on, then the amplifier is faulty.

### **AMPLIFIER(S) GETS VERY HOT.**

- Check that the minimum speaker impedance for that model is correct.
- Check for speaker shorts.
- Check that there is good airflow around the amplifier. In some applications, an external cooling fan may be required.

### **DISTORTED SOUND**

- Check that the Level control(s) is set to match the signal level of the head unit.
- Check that all crossover frequencies have been properly set.
- Check for shorts on the speaker leads.

### **HIGH SQUEAL NOISE FROM SPEAKERS.**

- This is almost always caused by a poorly-grounded RCA patch cord.

## WIRING

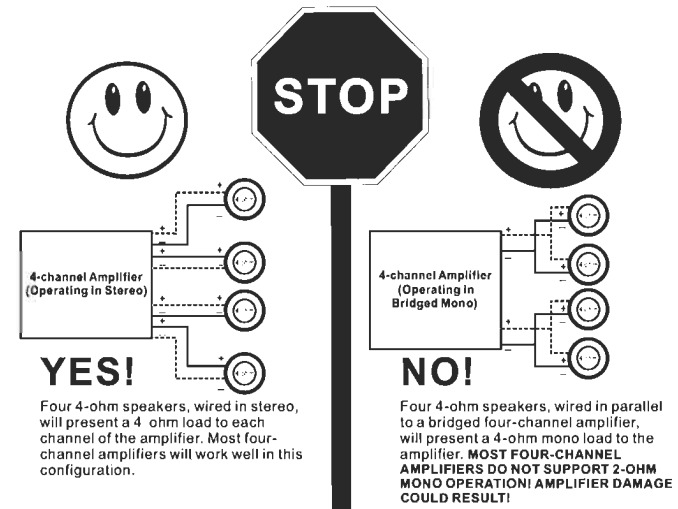
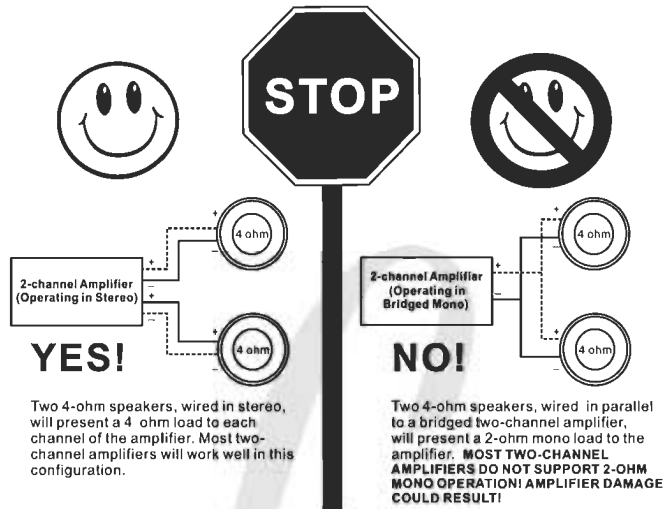

# Lanzar

SOUND AROUND, INC.  
1600 63RD STREET • BROOKLYN, NY 11204



o p t i

**Lanzar Audio Inc.**  
1600 63rd Street, Brooklyn, NY 11204  
(718) 236-6948  
[www.lanzar.com](http://www.lanzar.com)



PRINTED IN KOREA