



Read
and Retain
for Future
Reference

Cooper Bussmann BU-905U-L Wireless I/O Installation Manual

Version 1.6

Cooper Bussmann Application Engineering

- Phone 8:00 a.m - 5:00 p.m. Central, M-F (636) 527-1270
- Fax: (636) 527-1607
- E-mail: FuseTech@cooperindustries.com

Thank you for your selection of the BU-905U-L Wireless I/O. We trust it will give you many years of valuable service. Configuration Manual

CONTENTS

Contents2
Safety Information3
About this document4

Installing your unit4
Unit components and connections5
 Transmitter unit5
 Receiver unit7
Installing the antenna9
 Supported antennas9
 Radio transmission distances10
 Installing and earthing antennas11
 Omni-directional antennas (dipole and collinear)11
 - Dipole antennas11
 - Collinear antennas11
 Yagi directional antennas13
Installing the power supply14

Inputs and outputs15
Digital inputs15
Relay outputs17
Status outputs18
Analog input18
Thermocouple input20
Pulse input21
Analog output22

Installing and configuring the unit23
Installing the unit23
Configuring your units24
Testing your units25

Unit specifications26
Transmitter unit26
Receiver unit26
Ancillary hardware reference information27
 RS232 serial cable27

Index28

Safety Information

Thank you for selecting the BU-905U-L for your telemetry needs. We trust it will give you many years of valuable service. To ensure your BU-905U-L enjoys a long life, double-check ALL your connections with the Installation Guide before powering on the module.

WARNING - Incorrect termination of supply wires may cause internal damage and will void warranty.

Exposure to RF energy is an important safety consideration. The FCC has adopted a safety standard for human exposure to radio frequency electromagnetic energy emitted by FCC regulated equipment as a result of its actions in Docket 93-62 and OET Bulletin 65 Edition 97-01.

FCC Notice when used in USA: 905U Wireless I/O Module

<u>Part</u>	<u>Additional information</u>
15	This device has been tested and found to comply with the limits for a Class B digital device, pursuant to Part15 of the FCC rules (Code of Federal Regulations 47CFR Part 15). Operation is subject to the condition that this device does not cause harmful interference.
90	This device has been type accepted for operation by the FCC in accordance with Part90 of the FCC rules (47CFR Part 90). See the label on the unit for the specific FCC ID and any other certification designations.

Industry Canada: BU-905U-L Wireless I/O Module

RSS-119 - This device has been type accepted for operation by Industry Canada in accordance with RSS-119 of the Industry Canada rules. See the label on the unit for the specific Industry Canada certification number and any other certification designations.

NOTE: Any changes or modifications not expressly approved by Cooper Bussmann P/L could void the user's authority to operate this equipment.

To operate this equipment legally the user must obtain a radio-operating license from the government agency. This is done so the government can coordinate radio users in order to minimize interference.

Safety Information - FCC Notice

This device complies with Part 15.247 of the FCC Rules. Operation is subject to the following two conditions:

- This device may not cause harmful interference; and
- This device must accept any interference received, including interference that may cause undesired operation

NOTE: This equipment is suitable for use in Class 1 Division 2 groups A, B and C or non-hazardous locations only.

IMPORTANT ELECTRICAL SAFETY INFORMATION

In order to comply with Electrical Safety Regulations, this module must be installed in an Electrical AND Fire enclosure. This enclosure may be a single or multiple enclosures. Access to the module is to be made by a Service Person only.

About This Document

This document is the BU-905U-L Wireless I/O Installation Manual that describes how to install your BU-905U-L units and contains important information for installing your units with other equipment.

NOTE: If your network only contains one transmitter and receiver pair, you should also read the BU-905U-L QuickStart Guides.

This document contains the following sections:

Section	Read this section if you want to
Basic steps for using your unit	Learn the basic steps for installing and using your unit.
Factory default configuration	Understand how the transmitter sends information to the receiver.
Unit components	Understand the different parts of your unit.
Antenna installation	Learn how to install an antenna with your unit.
Resetting factory defaults	Reset your unit to the original factory default settings.
Linking transmitter and receiver units	Link your units to work as a dedicated pair.
Safety information	Understand important safety information related to your unit. NOTE: You must read this information before installing your unit.
Specifications	Know technical information about your unit.

For more information, see the next sections.

INSTALLING YOUR UNIT

This section describes how to install your unit and contains the following sections:

<u>Step</u>	<u>Description</u>	<u>For more information, see ...</u>
1. Read the safety information	Lets you understand important safety information related to your unit. NOTE: You must read this information before installing your unit.	Safety information on page 3.
2. Get to know the unit features	Understand the basic features of your unit.	Unit components and connections on page 5.
3. Install the antenna	Learn how to install an antenna with your unit.	Installing the antenna on page 9.
4. Install the power supply	Learn how to install a power supply for your unit.	Installing the power supply on page 14.
5. Install the units	Learn how to install your unit.	Installing the unit on page 23.
6. Linking and configuring the unit	Learn how to link and configure your units to transmit and receive information.	Configuring your units on page 24.
7. Test the unit	Understand the principles for testing your units.	Testing your units on page 25.

Note: To ensure internal surge protection works correctly, you must earth each unit using the Earth terminal.

For more information, see the next sections.

Unit Components and Connections

This section shows the components and terminal connections for the transmitter and receiver units.

Transmitter Unit

The BU-905U-L-T transmitter unit has the following components and terminal connections:

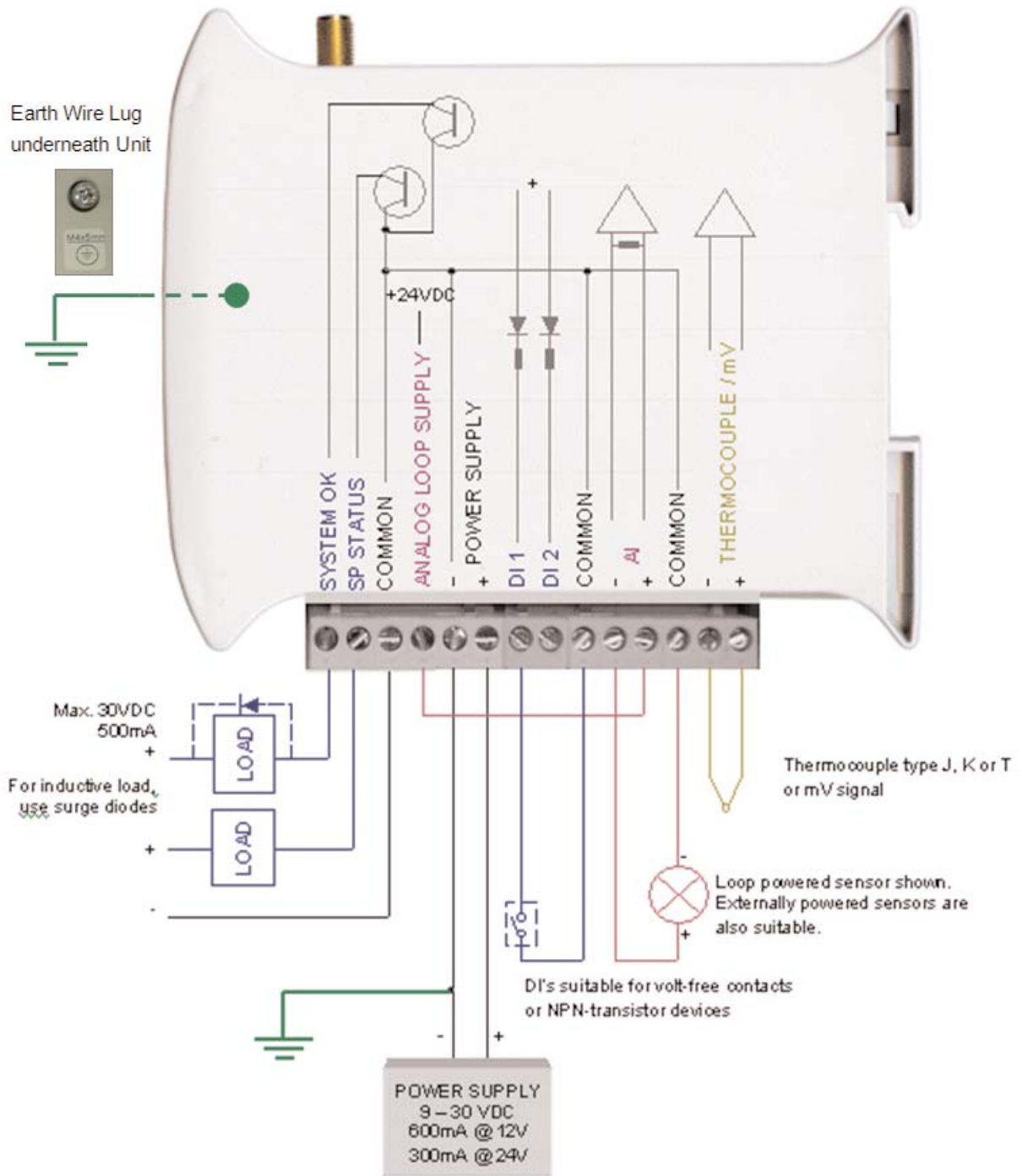

The front panel contains the following components:

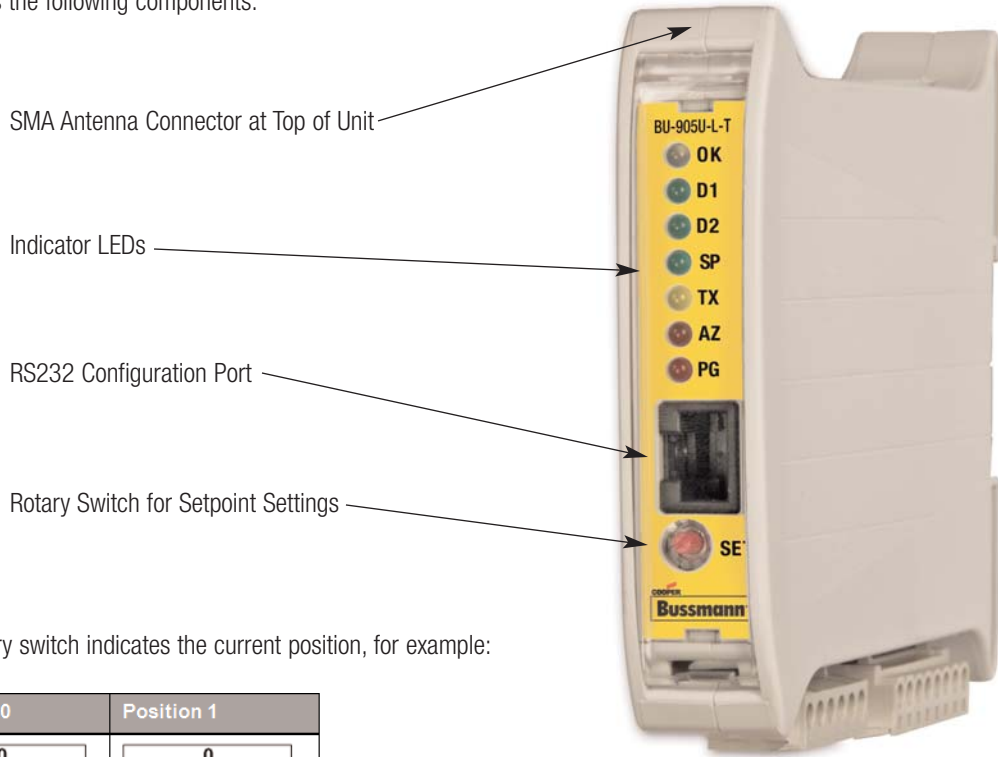

The triangle on the rotary switch indicates the current position, for example:

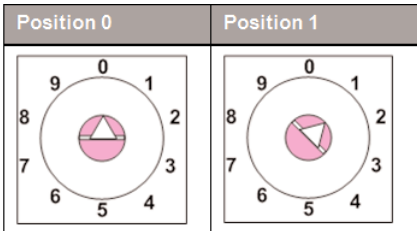

NOTE: To avoid damaging the rotary switch, use a screwdriver to change the position.

The rotary switch controls the setpoint levels on the Analog and Thermocouple inputs.

The LEDs on the front panel indicate the unit status:

LED Status

- None
- OK LED Green
- OK LED Red
- TX Led Flashes
- PG LED on
- Input LED ON

Indicates

- No power supply.
- Current status of the unit OK.
- Fault condition detected in unit.
- Transmitting Message.
- Configuration Cable Connected.
- Input LEDs (i.e., D1, D2, SP, AZ.) light when the corresponding input is active.
 - D1 | Digital Input 1 is active (Low).
 - D2 | Digital Input 2 is active.
 - SP | Analog Setpoint is active.
 - AZ | Analog Input is zero mA

All LEDs medium flash

Medium speed flash (1.6Hz) indicates the module is halfway through the configuration process. Medium flash also happens when you set the rotary switch to position 0 when powering on the unit.

Receiver Unit

Your BU-905U-L-R unit has the following components and terminal connections:

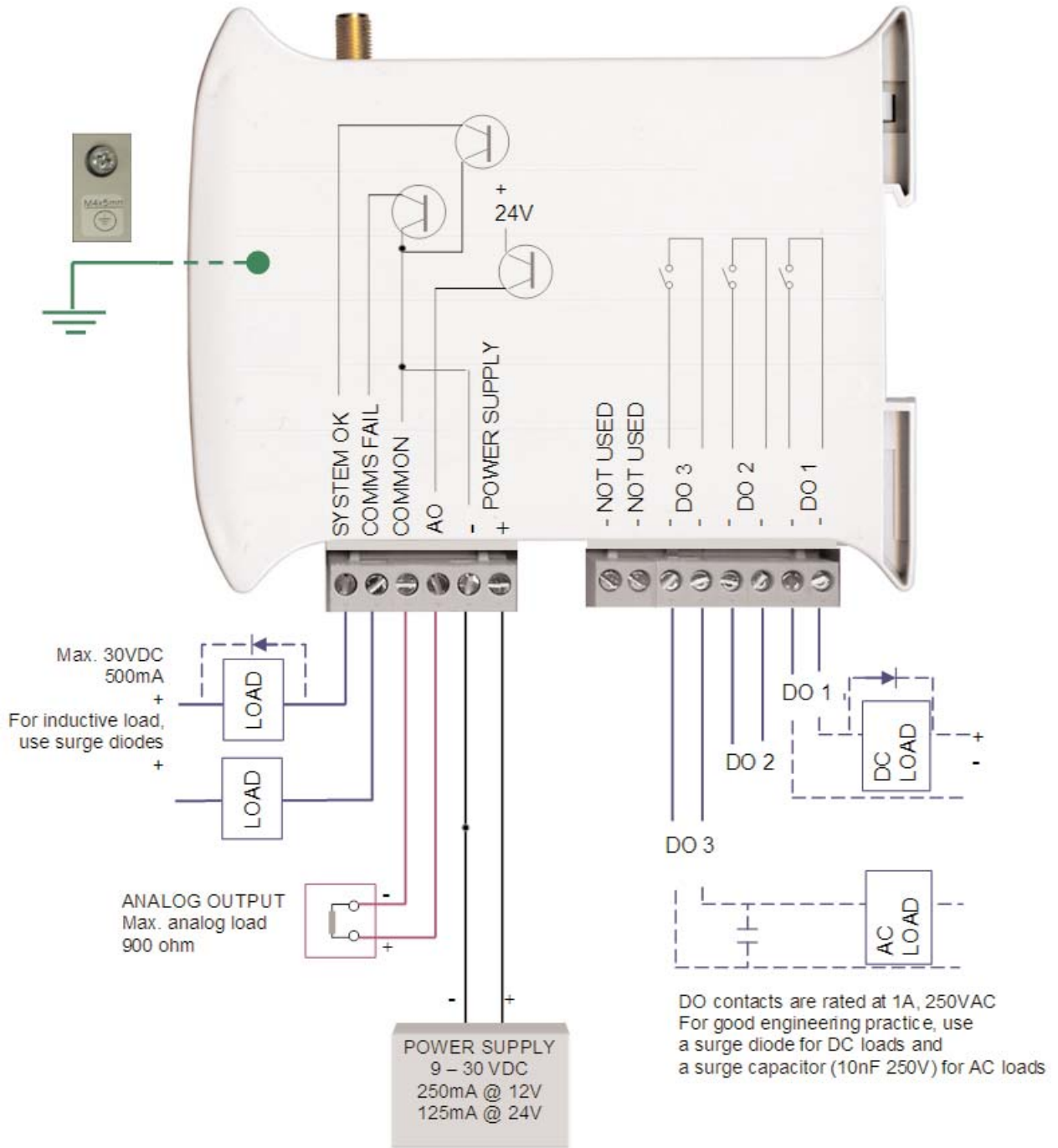

Cooper Bussmann BU-905U-L Wireless I/O Installation Manual

The front panel contains the following components:

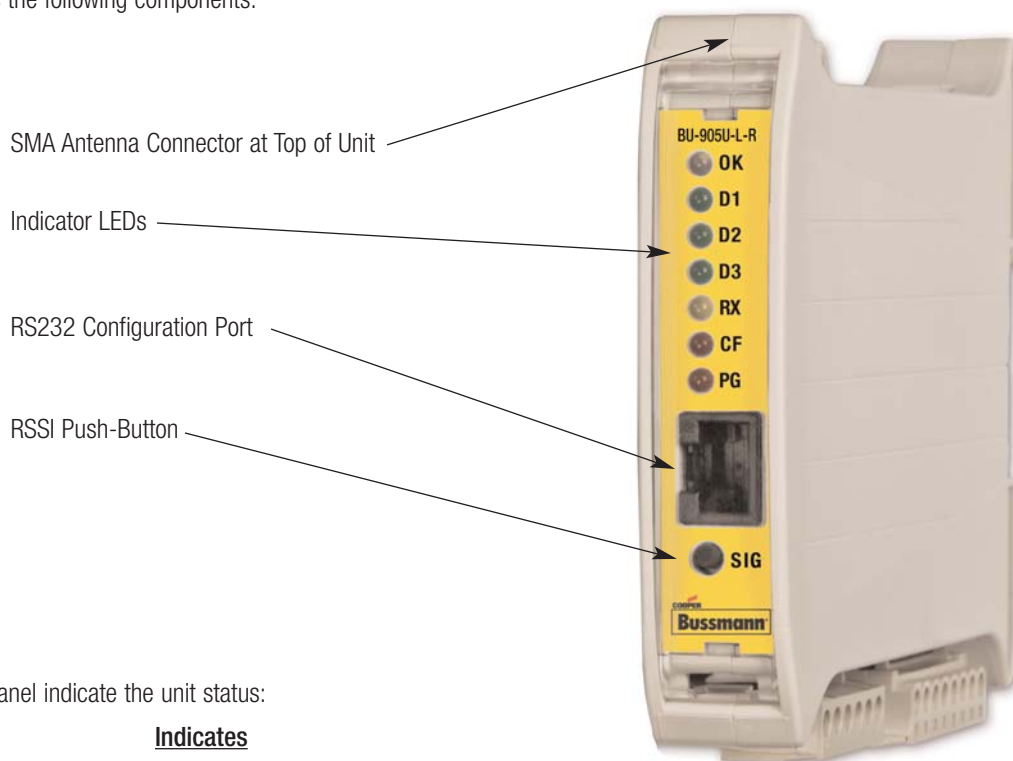

The LEDs on the front panel indicate the unit status:

LED Status

None
 OK LED Green
 OK LED Red
 RX Led Flashes
 CF Led ON
 PG LED on
 Output LED ON

Indicates

No power supply.
 Current status of the unit OK.
 Fault condition detected in unit.
 Receiving Message.
 Module Communication Failure Output is active.
 Configuration Cable Connected.
 The Output LEDs (i.e., D1, D2, D3) light when the corresponding output is active.
 D1 | Relay output D1 is ON (Contact Closed).
 D2 | Relay Output D2 is ON.
 D3 | Relay Output D3 is ON.

LEDs with RSSI Push Button Pressed

When you press the RSSI push button, the unit shows the signal strength by lighting the LEDs from the bottom to the top. Signal strength is the strength of the last message received that was addressed to this station.

LED	Signal Strength	LED	Signal Strength
D1	More than -85 dBm	RX	More than -100 dBm
D2	More than -90 dBm	CF	More than -105 dBm
D3	More than -95 dBm	PG	Always on during RSSI test

Output LED flashing quickly

If an output is in communication failure, the corresponding LED flashes at 5 Hz.

D1 | Relay Output D1 is in communication failure.
 D2 | Relay Output D2 is in communication failure.
 D3 | Relay Output D3 is in communication failure.
 PG | Analog output is in communications failure.

Installing the Antenna

This section explains how to install your antenna and contains the following sections:

<u>Section</u>	<u>Description</u>	<u>For more information, see ...</u>
Supported antennas and cables	Details the antennas and cables you can use with the units.	Supported antennas on page 9.
Radio transmission distances	Details the distances for reliable operation.	Radio transmission distances on page 10.
Installing and earthing antennas	Details important information about installing and earthing antennas.	Installing and earthing antennas on page 11
Omni-directional antennas	Details important information about using dipole and collinear antennas.	Dipole and collinear antennas on page 11.
Yagi directional antennas	Details important information about using Yagi antennas.	Yagi antennas on page 13.

For more information, see the next sections.

Supported Antennas

You can use the following antennas with the units:

<u>Antenna</u>	<u>Additional information</u>	<u>Total gain (including cable)</u>
BU-WH900-SMA	Whip antenna for mounting directly onto the module - operation up to ½ mile (1 km).	-6 dBi
BU-CFD890EL	0 dBi Dipole antenna with 15' of Cellfoil cable and SMA connector.	0 dBi
SG900EL	5dBi Collinear omni-directional antenna with N-type connector.	5 dBi
BU-SG900-6	8dBi Collinear omni-directional antenna with N-type connector.	8 dBi
BU-YU6-900	10dBi Yagi directional antenna with N-type connector.	10 dBi
BU-YU16-900	15dBi Yagi directional antenna with N-type connector.	15 dBi

You can use the following cables with the units:

The following table shows compatible cables for different antennas when used with the BU-905U-L-T:

<u>Antenna</u>	<u>North America</u>	<u>Australia/NZ</u>
BU-SG900EL	Any cable.	CC10 or CC20.
BU-SG900-6	Any cable.	CC20.
BU-YU6-900	CC20.	External cable with loss > 9dB.
BU-YU16-900	External cable with loss > 9dB.	External cable with loss > 15 dB

You must carefully select antennas for BU-905U-L-T modules to avoid contravening the maximum power limit on the unlicensed channel. The net gain of the antenna/cable configuration should be no more than 6dB in North America (USA, Canada, Mexico) and no more than 0 dB in Australia / New Zealand.

Note: The net gain of an antenna/cable configuration is the gain of the antenna (in dBi) less the loss in the coaxial cable (in dB).

Cooper Bussmann BU-905U-L Wireless I/O Installation Manual

For example, an BU-SG900-6 antenna with a BU-CC20-SMA cable kit has a net gain of 2dB (i.e., +8 dB – 6 dB) at 900 MHz.

The BU-905U-L-R module has no limitation on antenna gain, as this module does not incorporate a radio transmitter.

The following table details the gains of some typical antennas:

<u>Antenna</u>	<u>Gain (dBi)</u>
Dipole with integral 3m cable	0
Dipole without cable	2
5dBi Collinear (3dBd)	5
8dBi Collinear (6dBd)	8
3 element Yagi	5
6 element Yagi	10

The following table details losses for typical cables:

<u>Cable</u>	<u>Loss (dB per 10m) at 900 MHz</u>
RG58	-5
RG213	-2.5
Cellfoil	-3

Radio Transmission Distances

The unit will operate reliably over large distances depending on the:

- Antenna type;
- Antenna location;
- Amount of radio interference; and
- Radio path obstructions (e.g., hills or trees).

Typical reliable distances are:

<u>Area</u>	<u>Distance</u>	<u>Additional information</u>
USA/Canada	20+ miles	6dB net gain antenna configuration permitted (4W Equivalent RF power permitted).
Australia/NZ	20+ km	Unity gain antenna configuration (1W Equivalent RF power permitted).

To achieve these distance, you must elevate at least one site on a hill or transmission tower.

Modules will operate reliably with some radio path obstruction; however obstructions also reduce the reliable distance.

Note: You must test all obstructed paths to check the reliability of the path.

You can achieve maximum transmission distances if the radio path has “line of sight.” For example, raising antennas above intermediate obstructions including hills, trees, etc. Obstructions reduce the range; however they may not prevent a reliable path.

The closer the obstruction is to the antenna, the greater the blocking effect. For example, a group of trees around the antenna is a larger obstruction than a group of trees further away from the antenna. You can achieve longer distances by mounting one antenna on top of a hill.

Note; Due to the earth’s curvature, you must elevate antennas higher than the ground level between the antennas for longer paths (greater than 3 miles / 5 km).

The unit can tolerate larger amounts of obstructions for shorter distances. For very short distances, you can also mount the antennas inside buildings.

If two BU-905U-L modules cannot communicate reliably, you can use a third 905U module as a “repeater” to receive and re-transmit messages. This module may also have input/output (I/O) signals connected to it and form part of the I/O network.

NOTE:

1. Cooper Bussmann recommends using the 905U-G module as a repeater unit between BU-905U-L-T and BU-905U-L-R modules.
2. To use a repeater unit, the BU-905U-L modules and the repeater module must be configured using the supplied configuration software. The factory default configuration described in the Quick Start Guide cannot use a repeater unit.

Installing and Earthing Antennas

You must connect an antenna to each BU-905U-L module using the SMA connector at the top of the enclosure.

Cooper Bussmann recommends carefully taping the connections between the antenna and coaxial cable to prevent moisture ingress. Moisture ingress in the coaxial cable is a common cause of radio system problem as it greatly increases the radio losses.

Cooper Bussmann recommends taping the connection with three layers of tape:

<u>Layer</u>	<u>Tape</u>
1	PVC tape.
2	Vulcanizing tape (e.g. 3M 23 tape).
3	Additional layer of PVC UV-stabilized insulating tape.

The first tape layer lets you easily inspect the joint if required as you can easily remove the Vulcanizing seal.

Note: You must effectively earth all masts for mast-mounted antennas to avoid lightning surges. We also recommend using a coaxial surge diverter for antennas mounted outside industrial plant environments.

If the antenna is not already shielded from lightning strike by an adjacent earthed structure, you can provide shielding by installing a lightning rod above the antenna.

You should connect the antenna to the module using 50 ohm coaxial cable (e.g. RG58 or RG213) terminated with a male coaxial connector, The higher the antenna is mounted, the greater the transmission range; however as the length of coaxial cable increases so do cable losses. For use on unlicensed frequency channels, there are several types of antenna suitable for use.

If you mount antennas on elevated masts, you should effectively earth the masts to avoid lightening surges. The BU-905U-L radios are fitted with surge protection.

Note: For high lightening risk areas, Cooper Bussmann recommends additional surge suppression devices. If the antenna is not already shielded from lightening strike by an adjacent earthed structure, you can install a lightening rod to provide shielding.

Omni-directional Antennas

This section contains important information for using dipole and collinear antennas. For more information, see the next sections.

Dipole Antennas

Unity gain dipole antennas are commonly used on unlicensed channels. The dipole antenna does not provide any gain, so the power transmitted from the antenna is the same as the power out of the module.

A dipole antenna that comes supplied with integral 15 ft cable does not require additional coaxial cable.

You should mount dipole antennas vertically, preferably no less than 1 metre away from a wall or mast for maximum performance.

Collinear Antennas

Collinear antennas transmit the same amount of radio power in all directions horizontally, and are easy to install and use. They provide gain by compressing the radiated signal to a flattened disc shape, and reducing the amount of signal radiated above and below the horizontal plane.

Collinear antennas are generally used at a central site with more than one remote site, or at a repeater site.

Collinear antennas are similar in appearance to dipole antennas; however the antenna is longer.

Collinear antennas are supplied without cable, and require additional coaxial cable.

You can use collinear antennas to:

- Transmitter – to compensate for the losses in long lengths of coaxial cable.
- Receiver – to increase receive sensitivity.

The following diagrams shows the recommended installation for omni-directional antennas:

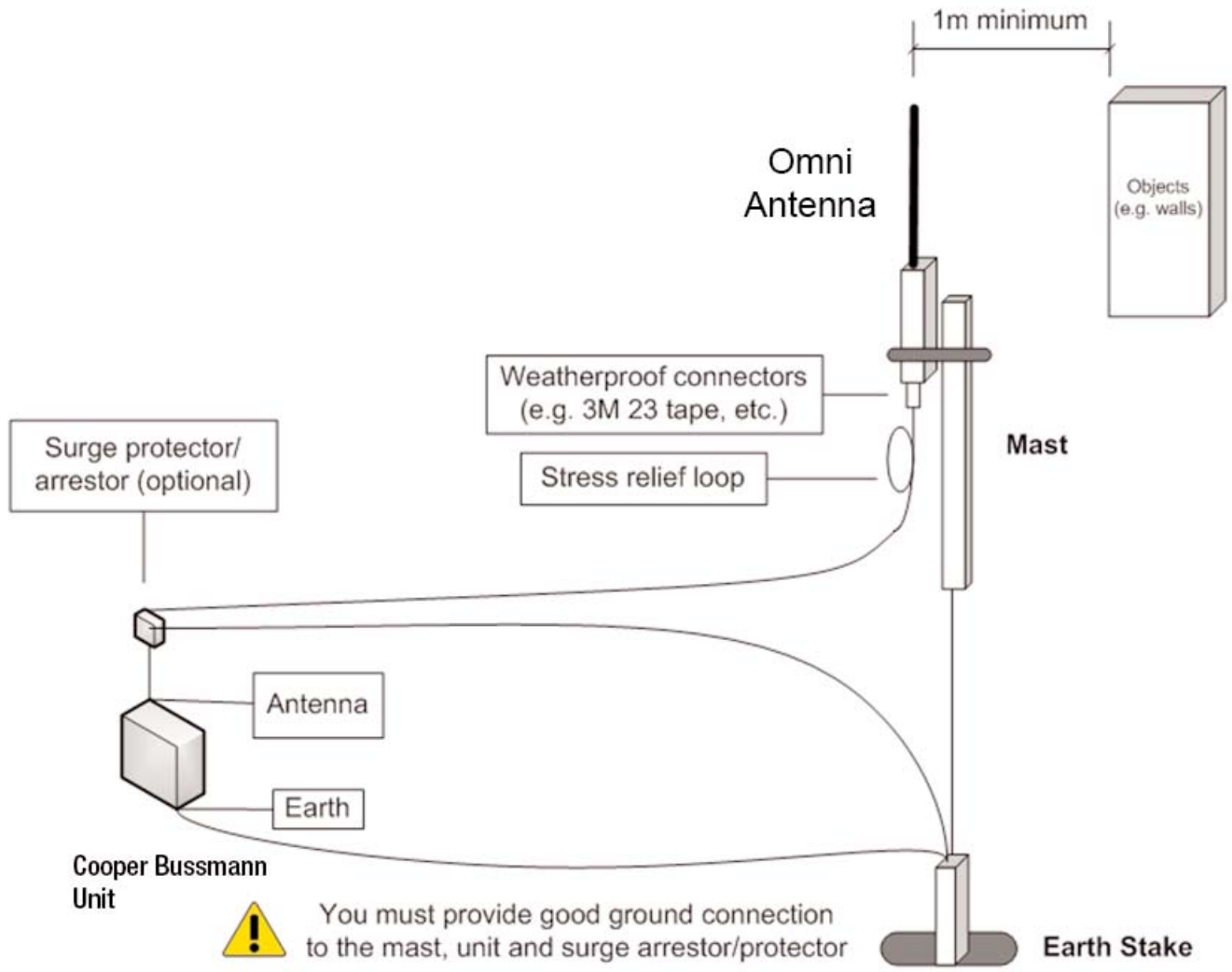

 You must provide good ground connection to the mast, unit and surge arrestor/protector

 You must install the aerial above all local obstructions.

Yagi Directional Antennas

Yagi antennas are directional and have positive gain to the front of the antenna and negative gain in other directions. You can use the gain to:

- Compensate for coaxial cable loss for transmitter unit; and
- Increase receive sensitivity for receiver units.

You should install Yagi antennas with the central beam horizontal and pointed directly in the transmission direction to benefit from the antenna gain.

Note: Yagi antennas usually have a drain hole on the folded element. You should position the drain hole at the bottom when installing the antenna.

You can install Yagi antennas:

- Vertically polarized – with the elements in a vertical plane; or
- Horizontally polarized – with the elements in a horizontal plane.

The following table shows the recommended installation mode for different situations.

<u>If your installation has ...</u>	<u>Cooper Bussmann recommends using ...</u>
Two stations both using Yagi antennas	• Horizontal polarization for the stations.
Two or more stations communicating with a common station	• Vertical polarization for the stations; and • Omni-directional (i.e., non-directional) antenna for the central station.

The following diagram shows the recommended installation for Yagi directional antennas.

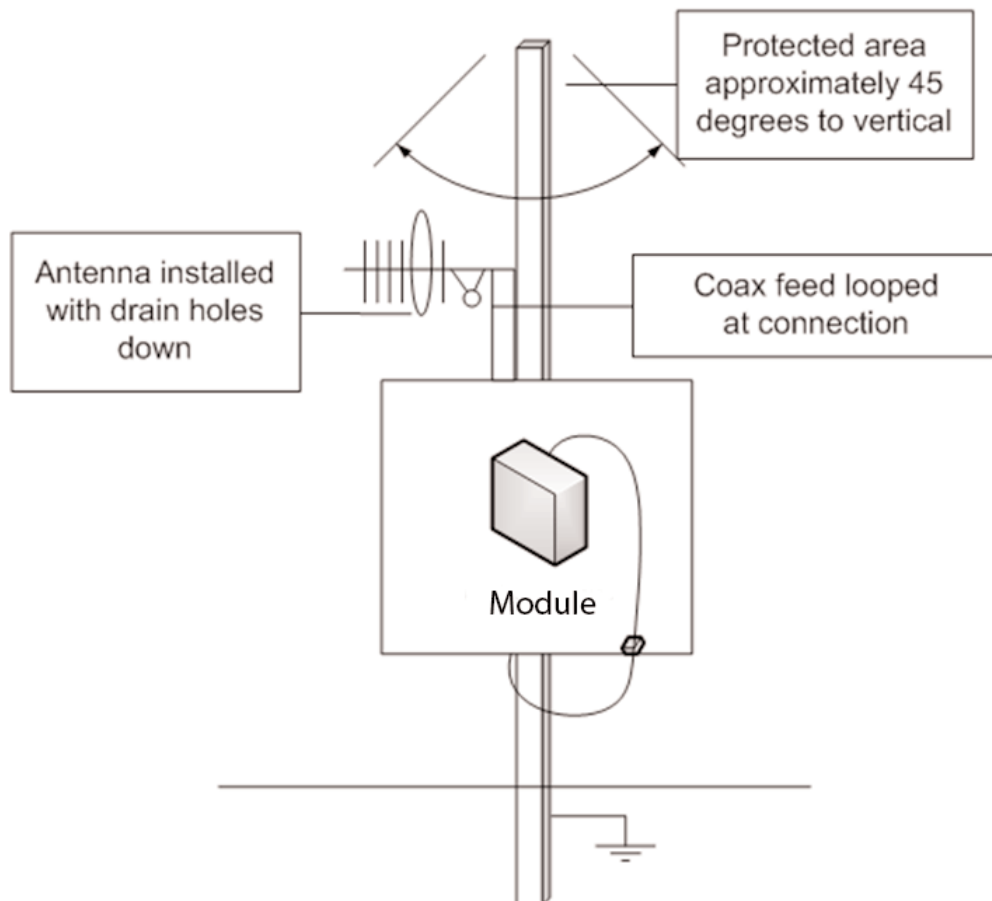

Installing the Power Supply

The unit works with a 9-30Vdc 0.6 Amp CSA certified Class 2 power supply. For use in Class 1 Div 2 hazardous locations, the power supply must be approved for Class 1 Div 2 use.

Warning – Explosion Hazard

Do not disconnect while circuit is live unless area is known to be non-hazardous.

The following table shows the power supply requirements:

<u>Power Supply</u>	<u>BU-905U-L-T</u>	<u>BU-905U-L-R</u>
12V	600mA	250mA
24V	300mA	125mA

The power supply can be a floating supply or negatively grounded.

The transmitter provides a 24Vdc regulated supply for analog loop power. The supply is rated at 35mA and should ONLY be used for powering analog loops.

To install the power supply:

1. Connect the positive lead to Power Supply Input.
2. Connect the negative lead to Ground.

Note: To ensure internal surge protection works correctly, you must earth each unit using the Earth terminal.

- You should connect the module to the same ground/earth point as the antenna mounting to avoid differences in earth potential during voltage surges.
- Do NOT connect the positive side of the supply to Earth.

3. The following diagram illustrates the connection:

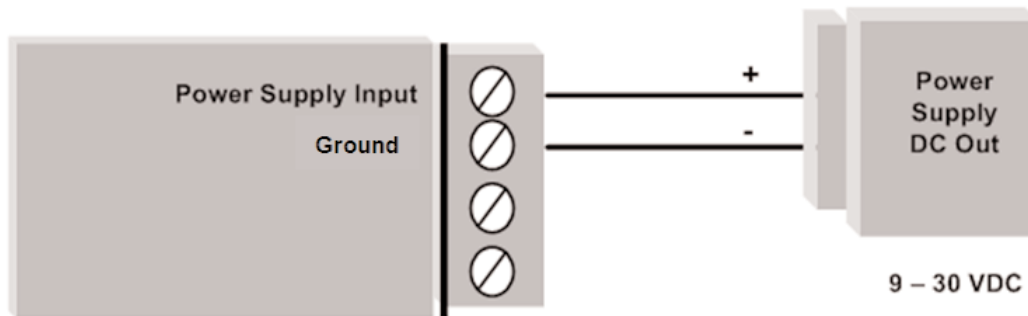

INPUTS AND OUTPUTS

The units have the following inputs and outputs:

Input/Output	BU-905U-L-T	BU-905U-L-R	Description	For more information, see ...
Digital inputs	2		Suitable for Voltage free contact, NPN transistor, 0-5V signal.	Digital inputs on page 15.
Relay outputs		3	250Vac 1A / 30Vdc 1A.	Relay outputs Important Information on page 17.
Status outputs	2	2	Max 30Vdc, 500mA. Indicate module status, communication failure and local setpoint status.	Status outputs on page 18.
Analog inputs	1		4-20mA with over-range and under-range. 0-10mA with over-range.	Analog input on page 18.
+24V Loop supply	1		Provides power for 1 external current loop (up to 35mA).	Installing the power supply on page 14.
Analog setpoint	1		Allows discrete setpoint to be controlled from analog input. Threshold adjustable via rotary switch.	Refer to the User Manual.
Thermocouple / millivolt input	1		Provides measurement of E, J, K, T type Thermocouple, millivolt signals and user-defined thermocouple types.	Thermocouple input on page 20.
Thermocouple Setpoint	1		Lets you control discrete setpoint from thermocouple with threshold adjustable via rotary switch.	Refer to the User Manual.
Pulse inputs	2		Up to 10Hz.	Pulse input on page 21.
Analog Output		1	0-22mA, suitable for loop powered, floating input or single-ended input device.	Analog output on page 22.

For more information, see the next sections.

Digital Inputs

The BU-905U-L-T module provides two digital inputs suitable for:

- Voltage free contacts – e.g., mechanical switches; or
- NPN Transistor devices – e.g., electronic proximity switches; or
- 0-5V Signals - 2V – 4V Minimum range.

Note: PNP Transistor devices are not suitable.

The unit provides contact wetting current of approximately 5mA to maintain reliable operation of driving relays.

Each digital input is connected between the appropriate Digital Input terminal and Ground.

Each digital input circuit includes a LED indicator that lights when the digital input is active (i.e., when the input circuit is closed).

To activate the digital input, the switching device resistance must be less than 200 ohms.

Connection Method

Example

Voltage free contact

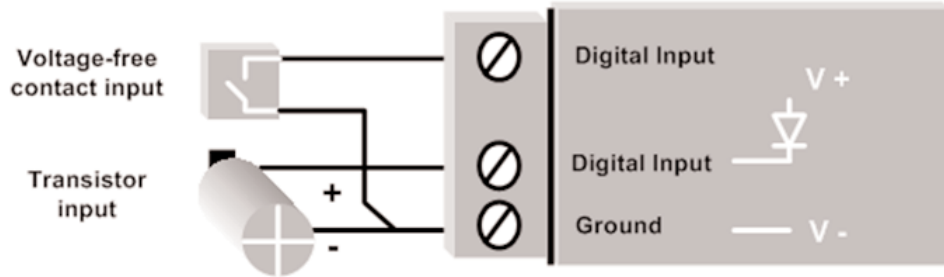

Active 0-5v signal device

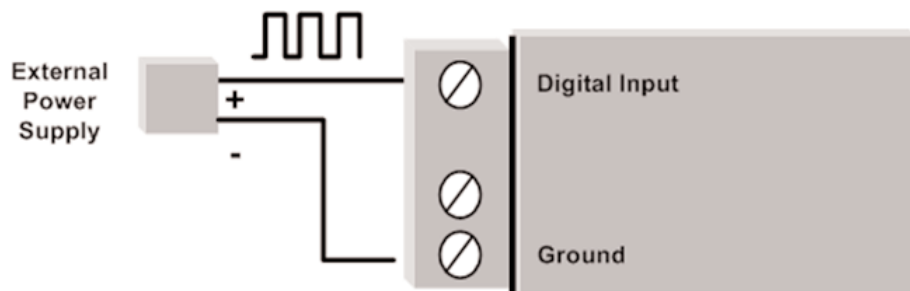

Note

Use a solid state relay if the voltage range is not suitable.
Voltage Range is low: 2V (max); high: 4V (min).

Relay Outputs

The BU-905U-L-R module provides three normally open voltage-free relay contacts rated at 250Vac / 30Vdc 1A.

You can use these outputs to directly control low-powered equipment or power larger relays for higher-powered equipment.

For inductive loads, Cooper Bussmann recommends:

DC relays - use flyback diodes across the external circuit to prevent arcing across the relay contacts.

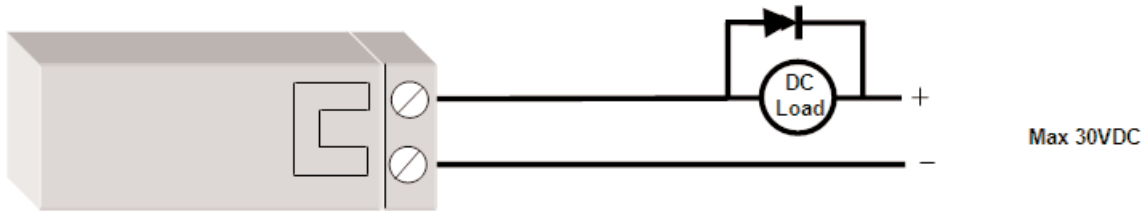

AC relays – use capacitors (e.g., 10nF 250V) to prevent arcing across the relay contacts.

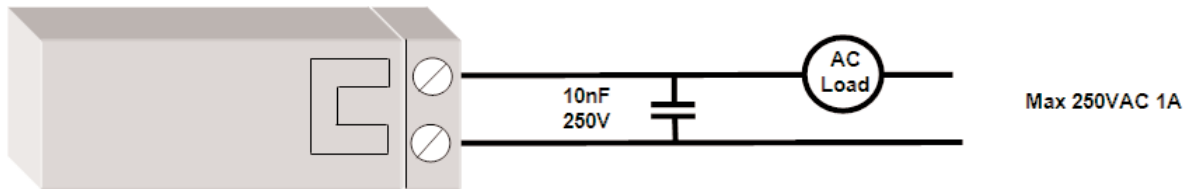

You can individually configure digital outputs to turn off if no command message is received by the output for a certain period. This feature provides an intelligent watchdog for each output, so communications failure at a transmitting site causes the output to revert to a known state.

The output circuit is connected to the appropriate pair of **Digital Output** terminals. Each digital output circuit includes a LED indicator that lights when the digital output is active. The LED flashes if the watchdog alarm is active.

IMPORTANT SAFETY INFORMATION

In order to comply with Electrical Safety Standards, when connecting SELV AND voltages which are greater than SELV (30Vac or 60Vdc) together, then Relay Output 2 must NOT be used in order to provide sufficient isolation between the outputs

Status Outputs

The unit contains the following status outputs:

- System OK;
- Setpoint Output; and
- Communications Failure.

Status outputs are FET output to common rated at 30Vdc 500mA.

Connect the output circuit to the appropriate Status **Output** terminal. Each status output circuit is associated with an LED indicator that lights lit when the digital output is active.

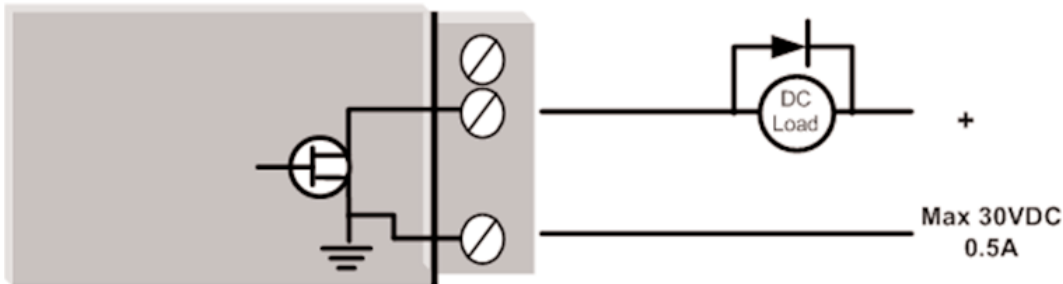

The following table details the status output behavior:

<u>Status Output</u>	<u>LED</u>	<u>LED Status</u>	<u>Description</u>
System OK active (both modules)	OK	Green	No fault detected
System OK inactive	OK	Red	<ul style="list-style-type: none"> • Internal fault detected. • Supply voltage Low • Analog Loop supply overloaded
Setpoint Output (BU-905U-L-T)	SP	Green	Local setpoint attached to 4-20mA analog input.
Communications Failure (BU-905U-L-R)	CF	Red	Watchdog alarms active on digital outputs or analog outputs.

Analog Input

The BU-905U-L-T module provides one 0-20mA DC analog input for connecting to instrument transducers (e.g. level, moisture, pressure transducers, etc.).

Note: The BU-905U-L-T module inputs measure down to 0mA and can also be used for zero based signals (e.g., 0-10mA).

The analog input has a positive and negative terminal and can be placed at any point in the current loop, providing neither input rises above the 24 volt Analog Loop Supply level.

Each input has a loop resistance of less than 250 ohms and zener diode protection is provided against over-voltage and reverse voltage.

Note: You may require additional protection in high voltage or noisy environments or for long wiring runs.

A 24Vdc loop supply is available on the BU-905U-L-T module for powering the analog transducer loops. In this situation, connect the:

- Analog loop - between an Analog Input (-) terminal and Ground.
- Positive terminal – i.e., Analog Input (+) to the +24V Analog Loop Supply.

Externally powered loops may be connected by connecting the input between "Analog Input (+)" and "Analog Input (-)" Common mode voltage may be -0.5V to 27V.

Cooper Bussmann recommends using shielded cable for analog I/O loops to minimize induced noise and Radio Frequency Interference (RFI).

Note: You should only connect one end of the cable shield to Earth

To connect an analog signal from a PLC or DCS output to an analog input on the BU-905U-L-T, you must carefully check the internal circuit of the output as different devices use different ways to create an analog signal.

The following diagrams illustrate different connection methods:

Analog Signal Source

Example

2-Wire Transducer

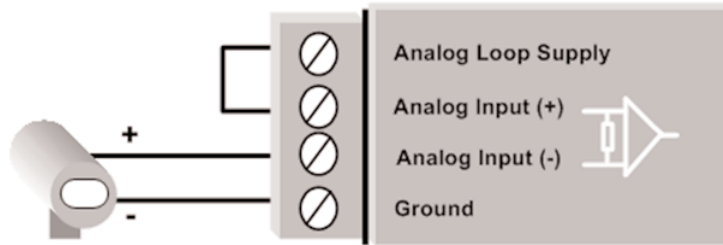

4-Wire Transducer

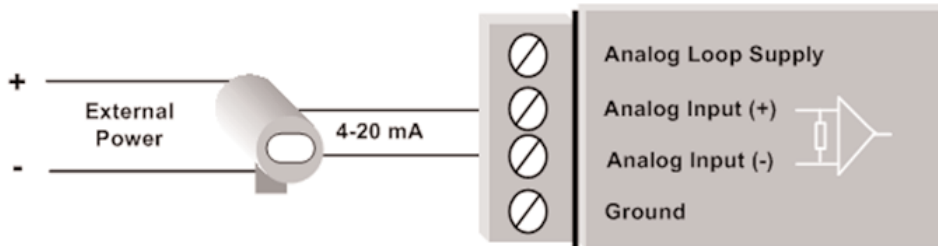

Note
Analog input must be within 27V of Ground.
If your terminal voltage exceeds this, you must use a loop isolator.

Current Source Output

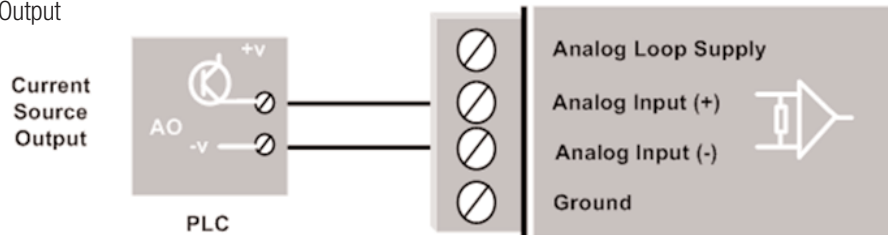

Note

1. Analog input must be within 27V of Ground.
 If your terminal voltage exceeds this, you must use a loop isolator.
2. Ground is connected to ground/earth.
 If you cannot ground the PLC COM, you must use a loop isolator.

Analog Signal Source

Current sink output

Example

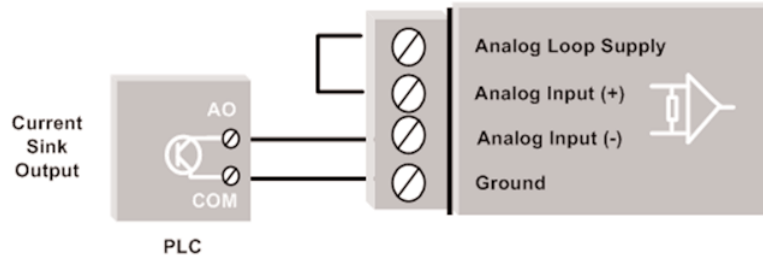

Note
1. Ground is connected internally to Earth.
If you cannot ground the PLC COM, you must use a loop isolator.

Thermocouple Input

The BU-905U-L-T provides one input suitable for connection to a thermocouple or a millivolt level signal. The module provides linearization tables for J, K and T type thermocouples and also supports other types via a user linearization table.

Millivolt signals in the range -10mV to +100mV are supported.

For more information on configuring the thermocouple input and cold-junction compensation to suit your application, refer to the User Manual.

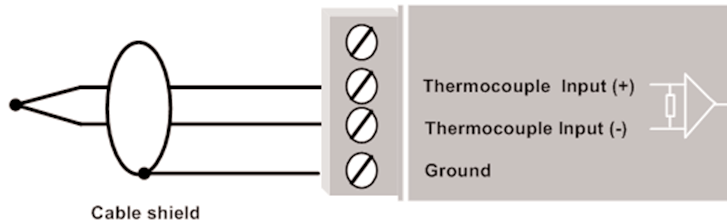

Pulse Input

The BU-905U-L-T module lets you configure the digital inputs as pulse inputs with the following characteristics:

<u>Characteristic</u>	<u>Value</u>
Maximum rate	10Hz
Minimum OFF time	20mSec
Minimum ON time	20mSec

Note: You should connect the pulse input in the same way as a digital input.

The following diagrams illustrate different connection methods:

Connection method

Example

Passive transistor

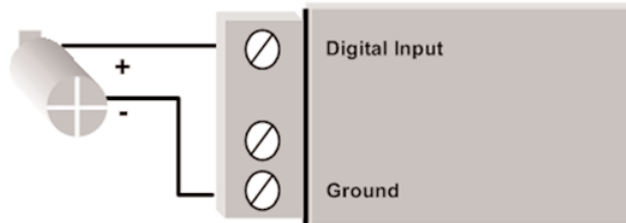

Active pulse device

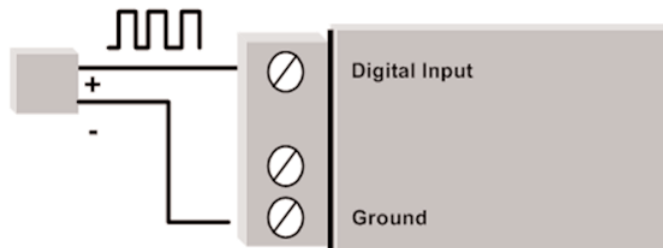

Note

**Use a solid state relay if the voltage range is not suitable.
Voltage Range is low: 2V (max); high: 4V (min).**

Analog Output

The BU-905U-L-R module provides a 4 - 20mA DC analog output for connecting to instrument indicators to display remote analog measurements. The analog output is a current source provided from an internally generated +24V loop supply.

When connecting to an external device (e.g. electronic indicator, recorder, PLC / DCS input, etc.) by connecting the output between the Analog Output terminal (+) and the COM terminal (-).

Note: Zener protection of analog outputs provides protection against short periods of over-voltage; however longer periods may result in module damage.

You can also individually configure analog outputs to turn off (i.e., 0mA) if no command message is received to the output for a certain period.

The following diagrams illustrate different connection methods:

Connection Method

Example

Loop powered device

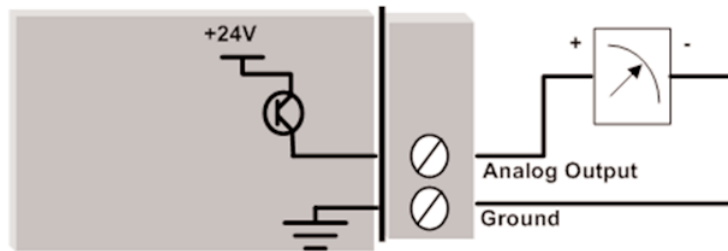

Floating input device

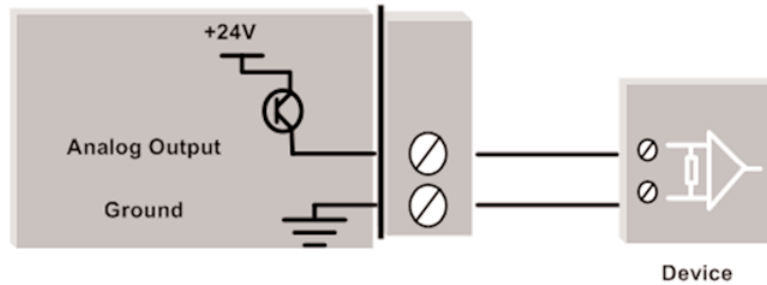

To single-ended input device

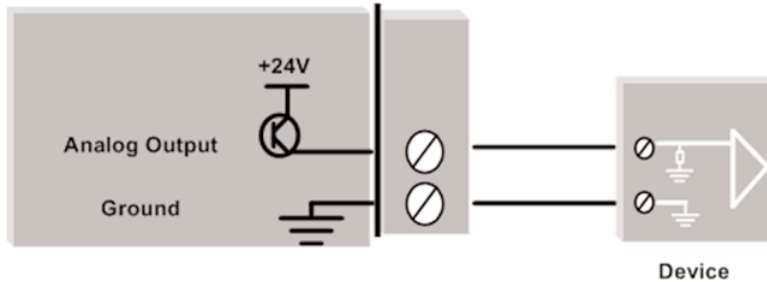

INSTALLING AND CONFIGURING THE UNIT

This section describes how to install and configure your unit and contains the following sections:

Section	Description	For more information, see ...
Installing the unit	Describes how to physically install your unit.	Installing the unit on page 23.
Configuring your unit	Describes the different ways to configure your unit.	Configuring your units on page 24.
Testing your unit	Describes the Bussmann recommendations for testing your unit.	Testing your units on page 25.

For more information, see the next sections.

Installing the Unit

To install the unit:

1. Connect signals to the supplied terminals.
2. Connect the radio antenna.
3. Install DIN rail to mount the module.
4. Clip the module to the DIN rail:



You can now configure your unit. For more information, Configuring your units on page 24.

Configuring Your Units

You can configure your network using:

- Default factory configuration – that lets you easily setup your network as a simple send/receive; or
- User-defined customized configuration – that lets you set specific information about your network and allows communication with other Cooper Bussmann BU-905U-L Series devices.

For more information on setting a user-defined customized configuration, see the User Manual.

For more information on setting the factory default configuration, refer to the Quick Start Guide included with your module.

The following table details the factory default configuration:

Signals Sent Over Radio

<u>BU-905U-L-T (Transmitter)</u>	<u>Sends</u>	<u>BU-905U-L-R (Receiver)</u>
Digital Input 1	⇒	Digital Output 1
Digital Input 2	⇒	Digital Output 2
Analog Setpoint	⇒	Digital Output 3
Analog input (4-20mA)	⇒	Analog output

Other Signals

<u>BU-905U-L-T (Transmitter)</u>	<u>BU-905U-L-R (Receiver)</u>
Thermocouple Input (Not used)	Communication Failure (Comes on if no messages from BU-905U-LT)
Setpoint Output (Local indication)	Communication Failure (Comes on if no messages from BU-905U-LT)
System OK (On if system OK)	System OK (On if system OK)

Testing Your Units

We recommend you bench test the complete system before installing a new system.

Configuration problems are easier to identify and fix when the units are next to each other.

The following table describes common problems and recommended solutions:

<u>If your installation has ...</u>	<u>You should check ...</u>	<u>Cooper Bussmann recommends ...</u>
Poor radio channel communications <ul style="list-style-type: none"> • TX LED flashes but no RX LED • Output LEDs flash quickly 	<ul style="list-style-type: none"> • The antenna installation. • For radio interference on the same channel. • The radio path is adequate. 	<ul style="list-style-type: none"> • Higher performance antennas if the path is too long. • Higher mounting points to overcome obstructions. • Using an intermediate unit as a repeater.
Red OK LED	<ul style="list-style-type: none"> • Power Supply voltage • Analog loop supply current • Module configuration 	<ul style="list-style-type: none"> • Supply should be between 9 and 30Vdc. • The analog loop supply is rated for 35mA max. • Your module configuration may be invalid. Re-load or restore factory default configuration.
TX LED flashes but no RX LED (bench testing)	<ul style="list-style-type: none"> • Ensure the BU-905U-L-R is set to the same country and frequency band as the BU-905U-L-T 	<ul style="list-style-type: none"> • Register the receiver with the transmitter. (Refer to the Quick Start Guide)
RX LED Flashes but no outputs change	<ul style="list-style-type: none"> • For a user-defined customized configuration, - check the configuration. • For default configuration, check the receiver is registered with the transmitter. 	<ul style="list-style-type: none"> • Check the configuration and reprogram the modules. • Repeat the procedure to register the receiver with the transmitter.

For support for other testing issues, please contact Cooper Bussmann.

UNIT SPECIFICATIONS

This section details the specifications for each unit.

Transmitter Unit

<u>Input/output</u>	<u>Number</u>	<u>Additional information</u>
Digital Inputs	2	Dry-contact digital inputs slow-pulsed at 10Hz. All inputs are suitable for voltage free contacts (e.g. mechanical switches) or NPN transistor devices (e.g. electronic proximity switches). NOTE: PNP transistor device inputs are NOT suitable.
Status Outputs	2	Separate System OK and Setpoint Status
Analog Inputs	1	0-20mA differential input; 16-bit resolution, 0.1% accuracy, 10 ohm input impedance.
Thermocouple Inputs	1	J, K or T Type thermocouple with on-board cold-junction compensation. Cold junction compensation accuracy $\pm 1^\circ$ over ambient temp range: -40° to $+70^\circ\text{C}$.
Power Supply	1	9-30Vdc 0.6 Amp CSA certified Class 2 power supply. For use in Class I Div 2 hazardous locations, the power supply must be approved for Class 1 Div 2 use. WARNING: Explosion hazard - do not disconnect while circuit is live unless area is known to be non-hazardous.
Transmitter	1	1-Watt Frequency Hopping Spread Spectrum (FHSS) Transmitter.
Frequency	902-928 MHz	Actual frequency range depends on country.

Receiver Unit

<u>Input/output</u>	<u>Number</u>	<u>Additional information</u>
Digital outputs	3	Voltage-free contacts rated at 250Vac, 1A, 30Vdc 1A 2 for digital inputs and 1 for setpoint.
Status outputs	2	Separate System OK and communication failure output.
Analog output	1	16-bit resolution, 0.1% accuracy, single-ended source output.
Power supply	1	9-30Vdc 0.25 Amp CSA certified Class 2 power supply. For use in Class I Div 2 Hazardous locations, the power supply must be approved for Class 1 Div 2 use. WARNING: Explosion hazard - do not disconnect while circuit is live unless area is known to be non-hazardous.
Radio receiver	1	High sensitivity FHSS UHF radio receiver.
Frequency	902-928 MHz	Actual frequency range depends on country.
Sensitivity	-110 dBm	At PER 8%.

Ancillary Hardware Reference Information

This section contains reference information about additional hardware components you may need for your unit.

RS232 Serial Cable

You can connect the unit to a PC using an RS232 serial cable to:

- Transfer configuration information;
- Perform factory and field-testing.

The serial port is an 8 pin RJ45 plug that communicates using standard RS232 signals:

<u>Signal information</u>	<u>Value</u>
Baud rate	9600
Bits	8 bits with 1 stop bit
Parity	No parity

Cooper Bussmann supplies a green configuration cable wired to the following pin-out:

Note: The following pin-out information is for reference only.

<u>RJ45</u>	<u>Required</u>	<u>Signal Name</u>	<u>Normal Color</u>	<u>DB9</u>
1		Ring Indicator	Green / White	9
2		Data Carrier Detect	Green	1
3	Y	Data Terminal Ready	Orange / White	4
4	Y	Signal Common	Blue	5
5	Y	Receive Data (from Modem)	Blue / White	2
6	Y	Transmit Data (to Modem)	Orange	3
7		Clear to Send	Brown / White	8
8		Request to Send	Brown	7

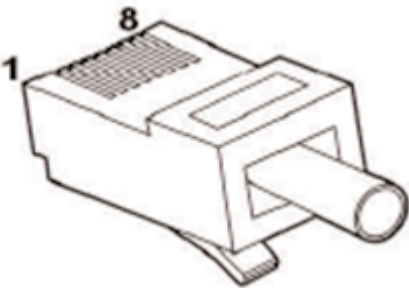

INDEX

2-Wire transducer	19	interference	10	setpoint	
4-Wire transducer	19	internal surge protection	14	thermocouple	15
AC relays	17	LEDs		setpoint levels	6
active pulse device		receiver	8	SG900-6	9
See active signal device	15	transmitter	6	SG900EL	9
analog input	18	lightening rod	11	shielding	11
analog output	22	lightening strike	11	signals	24
antennas	11	line of sight	10	single-ended input device	22
compatible cables	9	linearization tables	20	SMA connector	11
dipole	11	loop powered device	22	solutions	25
installing	9	maximum transmission distance	10	specifications	26
polarization	13	mechanical switches	15	status outputs	18
supported antennas	9	millivolt signal	20	surge diverter	11
arcing	17	net gain	9	surge protection	11
bench testing	25	obstructions	10	surge suppression	11
cable		intermediate	10	switches	
loss	9	overvoltage	18	electronic proximity	15
cables		passive transistor	21	switches	
for antennas	9	pin-out	27	mechanical	15
supported cables	9	PLC	18	taping connections	11
CFD890EL	9	polarization	13	testing	25
coaxial surge diverter	11	polarized	13	thermocouple	20
configuration		power supply	14	thermocouple setpoint	15
default factory	24	installing	14	transducers	18
user-defined customized	24	problems	25	transmitter	
configuring	24	pulse input	21	components	5
connections		PVC tape	11	front panel	6
taping	11	Radio Frequency Interference	18	terminal connections	5
current sink output	20	receiver		UV-stabilized tape	11
current source output	19	components	7	vertical polarization	13
DC relays	17	front panel	8	voltage free contact	15
DCS	18	LEDs	8	Vulcanizing tape	11
digital inputs	15	terminal connections	7	watchdog alarm	17
DIN rail	23	relay outputs	17	WH900	9
dipole antennas	11	reliable path	10	YU16/900	9
electronic proximity switches	15	repeater	10	YU6/900	9
explosive areas	14	reverse voltage	18	zener diode protection	18
floating input device	22	RFI	18	zero based signals	18
flyback diodes	17	RJ45	27		
gain		rotary switch	6		
net gain	9	changing position	6		
horizontal polarization	13	setpoint levels	6		
installing	23	RS232	27		
instrument transducers	18	serial cable	27		

Customer Assistance

Customer Satisfaction Team

Available to answer questions regarding Cooper Bussmann products & services Monday-Friday, 8:00 a.m. – 4:30 p.m. for all US time zones.

Contact:

- Toll-free phone: 855-287-7626 (855-BUSSMANN)
- Toll-free fax: 800-544-2570
- E-mail: busscustsat@cooperindustries.com

Emergency and After-Hours Orders

Next flight out or will call shipment for time-critical needs. Customers pay only standard product price, rush freight charges, & modest emergency service fee. Place these orders through the Customer Satisfaction Team during regular business hours. For after-hours, contact:

- Phone: 314-995-1342

C³ – the Enhanced, Online Cooper Customer Center

Provides real time product availability, net pricing, order status & shipment tracking across six Cooper divisions: B-line, Bussmann, Crouse-Hinds, Lighting, Power Systems & Wiring Devices. Available at:

- www.cooperc3.com
- 877-995-5955 for log-in assistance

Application Engineering

Technical assistance is available to all customers. Staffed by degreed engineers, this application support is available Monday-Friday, 8:00 a.m. – 5:00 p.m. CT

Contact:

- Phone: 636-527-1270
- Fax: 636-527-1607
- E-mail: fusetech@cooperindustries.com
- Live Chat: www.cooperbussmann.com

Online Resources

Visit www.cooperbussmann.com for the following resources:

- Product search & cross-reference
- Product & technical materials
- Solutions centers for information on topical issues including arc-flash, selective coordination & short-circuit current rating
- Technical tools, like our arc-flash calculator
- Where to purchase Cooper Bussmann product

Services

Cooper Bussmann Services team provides engineering expertise in electrical system reviews, electrical safety training & component testing for Agency compliance.

Contact:

- Phone: 636-207-3294
- E-mail: services@cooperindustries.com

Cooper Bussmann
St. Louis, MO 63178
855.287.7626 (855-BUSSMANN)
www.cooperbussmann.com

Your Authorized Cooper Bussmann Distributor is:

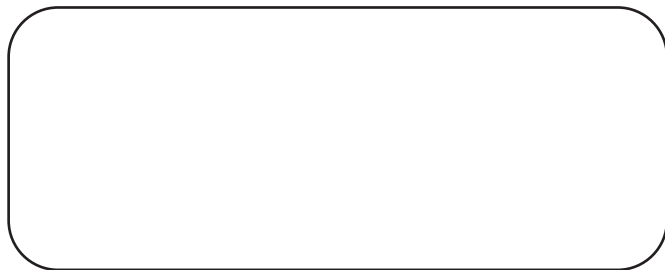

©2011 Cooper Bussmann
www.cooperbussmann.com

PDF Only

www.cooperbussmann.com/BussmannWirelessResources

COOPER Bussmann

3A1580Rev1.6