

OWNER'S MANUAL

Model No. GR80

GEORGE FOREMAN'S

**LEAN
MEAN
FAT
ROASTING
MACHINE**

George Foreman



Rotisserie Oven

**Big
GEORGE**

Important Safeguards

When using electrical appliances, basic safety precautions should always be followed, including the following:

1. Read all instructions carefully.
2. Do not touch hot surfaces. Use handles or knobs.
3. To protect against electrical shock, do not immerse cord, plug, or any part of the appliance in water or any other liquid.
4. Close supervision is necessary when any appliance is used by or near children.
5. Unplug from outlet when not in use and before cleaning. Allow to cool before putting on or taking off parts and before cleaning.
6. Do not operate any appliance with a damaged cord or plug or after the appliance malfunctions or has been damaged in any manner.
7. The use of accessory attachments not recommended by the manufacturer may cause fire, electric shock or injury.
8. Do not use outdoors.
9. Do not let cord hang over edge of table or counter, or touch hot surfaces.
10. Do not place on or near a hot gas or electric burner, or in a heated oven.
11. Extreme caution must be used when moving an appliance containing hot oil, grease, or other hot liquids.
12. Do not insert oversized foods or metal utensils (except recommended accessories) into the Rotisserie. Doing so may create a fire or risk of electric shock.
13. A fire may occur if the Rotisserie is covered or touching flammable material including curtains, draperies, walls or similar materials when in operation. Do not store any item on top of the Rotisserie.
14. Use extreme caution when removing the Drip Tray or disposing of hot grease.
15. Do not use appliance for other than intended use.

Save These Instructions

THIS APPLIANCE IS FOR HOUSEHOLD USE ONLY

Additional Important Safeguards

WARNING: This appliance generates heat and escaping steam during use. Proper precautions must be taken to prevent the risk of burns, fires, other injury to persons or damage to property.

1. A person who has not read and understood all operating and safety instructions is not qualified to operate this appliance.
2. **Unplug from outlet when not in use and before cleaning. To avoid electric shock, never immerse or rinse this appliance in water or any other liquid.**
3. If this appliance falls or accidentally becomes immersed in water, unplug it from the wall outlet immediately. **Do not reach into the water!**
4. To reduce the risk of burns or other injuries, do not touch hot surfaces. Use of protective oven mitts or gloves as well as long-handled utensils is recommended. Use the Bar Remover when removing Rotisserie Bar and hot food from inside the Rotisserie.
5. To reduce the risk of injury to persons or property, unplug this appliance before inserting food. Always keep the appliance unplugged from the wall outlet when not in use.
6. When using this appliance, provide adequate air space above and on the sides for air circulation. Do not operate this appliance while it is touching or near curtains, wall coverings, clothing, dish towels or other flammable materials.
7. To reduce the risk of fire, do not leave this appliance unattended during use.
8. If this appliance begins to smoke or malfunction during use, immediately unplug the cord. Do not use or attempt to repair a malfunctioning appliance!
9. The cord to this appliance should only be plugged into a 120V AC electrical wall outlet.
10. Do not use this appliance if any part is cracked or damaged, or if the grips are loose, weakened, or broken. Contact consumer service.
11. Do not use this appliance in an unstable position.
12. Do not place any of the following materials in the Rotisserie: paper, cardboard, plastic, and the like.
13. Do not attempt to dislodge food or clean the Rotisserie while it is plugged in or while it is still hot.
14. Do not attempt to use this appliance without the Cover in place.

Polarized Plug

This appliance has a polarized plug (one blade is wider than the other). To reduce the risk of electric shock, this plug is intended to fit into a polarized outlet only one way. If the plug does not fit fully into the outlet, reverse the plug. If it still does not fit, contact a qualified electrician. Do not attempt to modify the plug in any way.

Short Cord Instructions

A short power supply cord is provided to reduce the risk resulting from becoming entangled in or tripping over a longer cord. Longer extension cords are available and may be used if care is exercised in their use.

If a longer extension cord is used, (1) the marked electrical rating of the extension cord should be at least as great as the electrical rating of the appliance, and (2) the longer cord should be arranged so that it will not drape over the counter top or table top where it can be pulled on by children or tripped over unintentionally.

Getting to Know Your George Foreman Rotisserie Oven

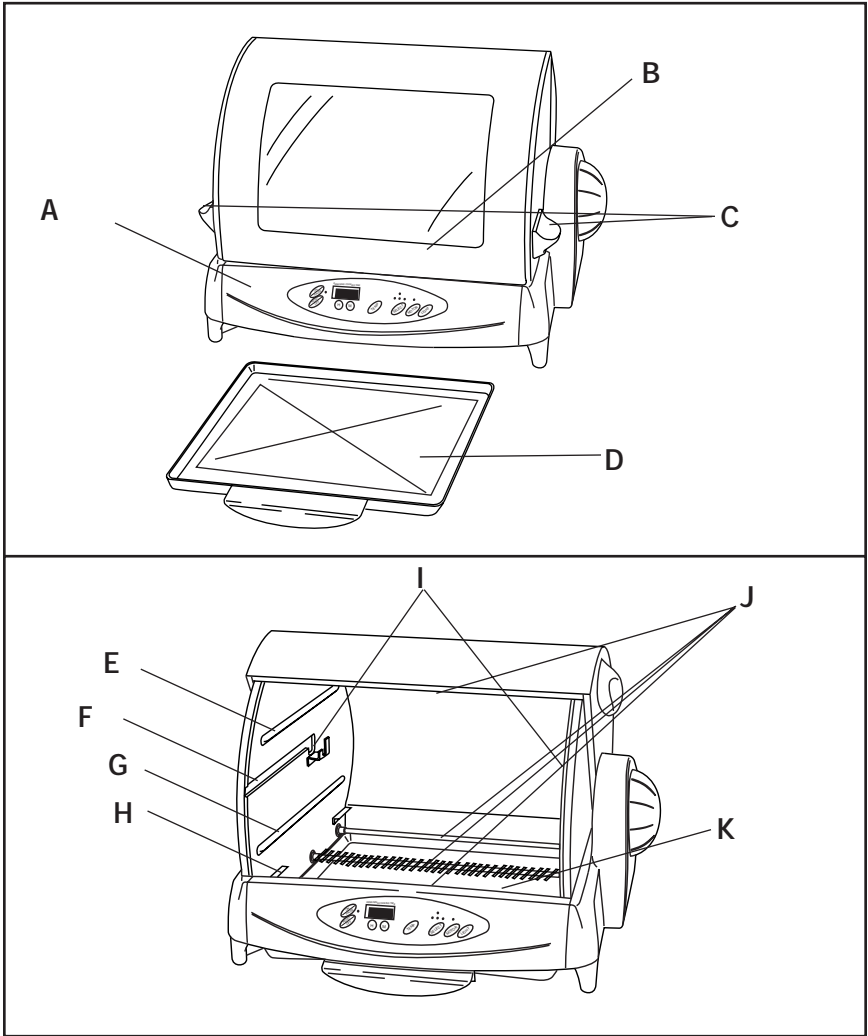

- A. Rotisserie Body
- B. Lift-up cover with Viewing Window
- C. Cover Handles
- D. Drip Tray w/ Handle (P/N 20899)
- E. Wire Rack Track
- F. Rotisserie Bar Track
- G. Baking Sheet/Wire Rack Track
- H. Wire Rack Ledges (4)
- I. Rotisserie Bar Sockets
- J. Heating Elements (1 upper; 3 lower)
- K. Oven Light

Getting to Know Your George Foreman Rotisserie Oven (Cont.)

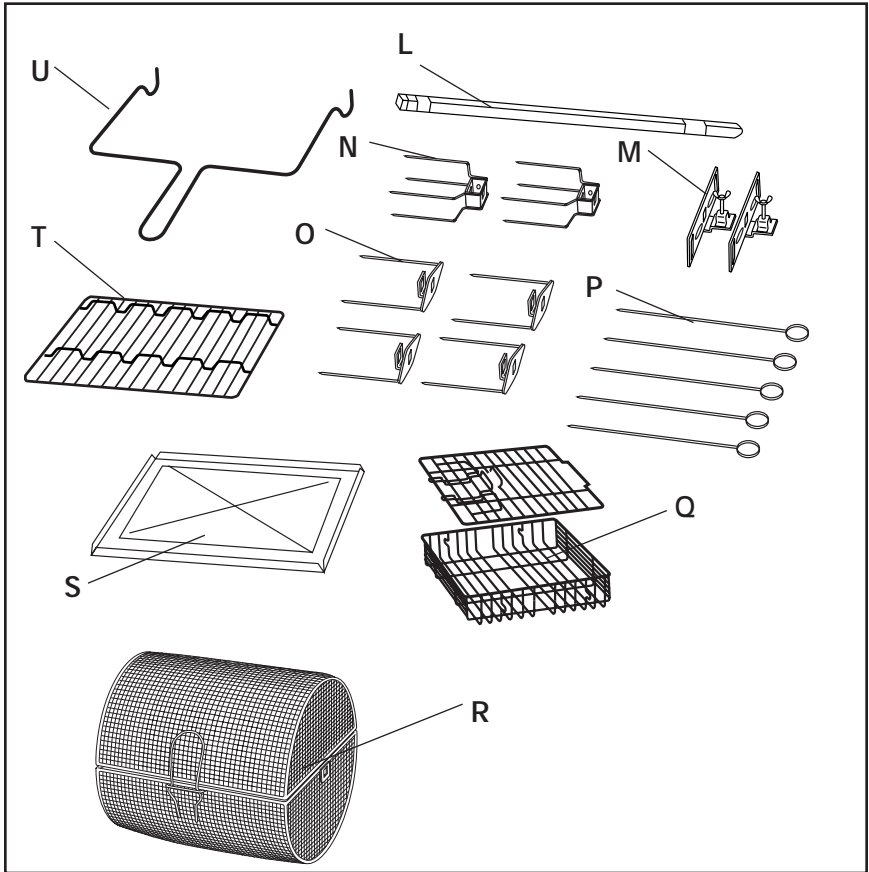

Accessories

- L.** Rotisserie Bar with Grooves (P/N 20897)
- M.** End Brackets (2) (P/N 20898)
- N.** 4-Prong Meat Tines (P/N 20907)
- O.** 2-Prong Meat Tines (P/N 20900)
- P.** Skewers (5) (P/N 20901)
- Q.** Adjustable Basket (P/N 20902)
- R.** Roasted Veggies/Air Bake Basket (P/N 20903)
- S.** Baking Sheet (P/N 20904)
- T.** Wire Rack (P/N 20905)
- U.** Rotisserie Bar Remover (P/N 20906)

Getting to Know Your George Foreman Rotisserie Oven (cont.)

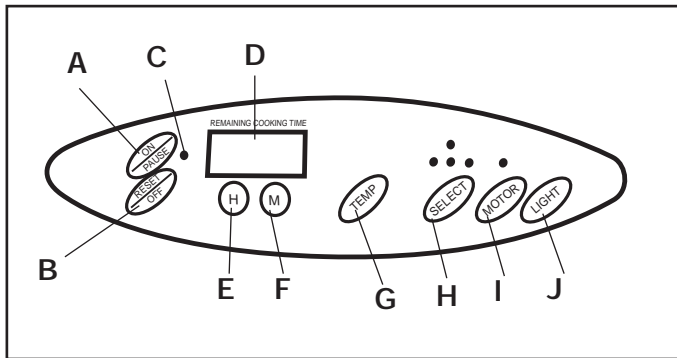

Control Panel

- A. On/Pause Button
- B. Reset/Off Button
- C. On Indicator Light
- D. LCD Timer Display
- E. Hour Button

- F. Minute Button
- G. Temperature Button
- H. Select (Heating Elements) Button
- I. Motor (on/off) Button
- J. Oven Light (on/off) Button

Temperature Button

The "TEMP" Button adjusts the cooking temperature. As you press the "TEMP" Button, you will notice six different temperature settings designated by 1-6 small dots appearing on the far left side of the LCD Timer Display. (Please note that actual temperatures may vary from the temperatures listed below.) Each setting, 1-6, can be associated with certain cooking temperatures. The settings and corresponding temperatures are as follows:

Symbol Temperature

•	225°F
••	300°F
•••	350°F

Symbol Temperature

••••	400°F
•••••	425°F
••••••	450°F

Getting to Know Your George Foreman Rotisserie Oven (cont.)

Select Button

The "SELECT" Button controls the Heating Elements. By being able to control the Heating Elements, you can adjust the browning if the food is cooking/browning unevenly. Each of the Heating Elements is represented by an LED above the "SELECT" Button. The four LEDs match the four Heating Elements inside the Rotisserie Oven. The LED on the top corresponds to the Heating Element on the top of the Rotisserie Oven. The left LED and the right LED on the bottom correspond to the front and back Heating Elements on the bottom of the Rotisserie Oven. The Center LED on the bottom corresponds to the center Heating Element on the bottom of the Rotisserie Oven. The Default setting for the Select Button is to turn on the Front and Back Heating Elements. However, we recommend you begin cooking with all four heating elements turned on. Then, as necessary, you may adjust the number of heating elements used to either slow down or speed up the cooking process.

Motor Button

The "MOTOR" Button controls the Rotisserie Motor. Press the "MOTOR" Button to turn the motor on or off. When using the Baking Sheet or Wire Rack, you will not need to turn on the Rotisserie Motor.

Introduction

Your George Foreman Rotisserie Oven is a combination Rotisserie and Oven. With a powerful motor, large cooking area, and heavy-duty Rotisserie Bar the Rotisserie Oven will beautifully and evenly cook an extra-large turkey!

Complete with all the accessories you'll need, your George Foreman Rotisserie Oven allows you to cook anything from delicate fish or vegetables to large poultry items and even a pizza! Cook fish or hamburgers in the Adjustable Basket or cook "guilt-free" air-baked fries in the Roasted Veggies/Air Bake Basket. Any way you cook it—it's healthy and delicious!

ROTISSERIE

Foods which are cooked on a Rotisserie are extra flavorful, because they are self-basted with their own juices. Foods are more healthful as fat can drip down, away from food during cooking.

Food to be cooked on the Rotisserie must be no longer than 12 inches. This allows the entire piece of food to be over the Heating Elements. Weight of food to be cooked is less important than length.

Carefully center food (especially food with a bone in it) on Rotisserie Bar, as unbalanced food will cause a jerking motion during cooking. This causes undue stress on the Motor. Use the Meat Tines to center the food and secure onto Rotisserie Bar with End Brackets. When using 4-prong Meat Tines for extra-large cuts of meat, you may eliminate the End Brackets (to make more room on Rotisserie Bar). Properly centered food can usually be judged by sight; however, test for balance by rotating the Rotisserie Bar with your hands. You will feel a "jerking" motion if the food is not balanced properly. Adjust food as necessary.

To ensure proper cooking, set food as close to the Heating Elements as possible without allowing the food to touch the Heating Elements. Use cooking string to tie poultry at wings and legs. This will compact the bird so no parts touch the Heating Elements.

Introduction (Cont.)

ACCESSORIES

Rotisserie Bar

Your George Foreman Rotisserie Oven features a heavy-duty Rotisserie Bar which hosts accessories such as the Meat Tines, Adjustable Basket, and Roasted Veggies/Air

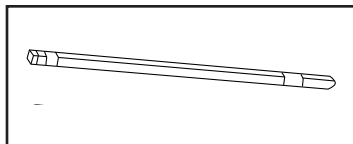

Bake Basket. The Rotisserie Bar fits into the Rotisserie Oven and the heavy-duty motor turns the Bar so your food cooks evenly and conveniently—without all the added fat!

A handy Rotisserie Bar Remover hooks into grooves in the Rotisserie Bar for quick and easy removal of your cooked foods!

4-Prong Meat Tines

Your George Foreman Rotisserie Oven comes with two 4-prong Meat Tines. Use the 4-prong Meat Tines for whole turkeys or other large pieces of meat. When using Meat Tines, be sure to place a Meat Tine at each end of the meat. This accessory is designed to be used with the Rotisserie Bar.

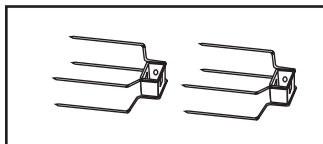

Suggested foods: Whole turkey or large chicken, duck, large roast, etc.

2-Prong Meat Tines

Your George Foreman Rotisserie Oven comes with four 2-prong Meat Tines. Use the 2-prong Meat Tines with chickens, cornish hens, roasts, etc. When using Meat Tines, be sure to place a Meat Tine at each end of the meat. This accessory is designed to be used with the Rotisserie Bar.

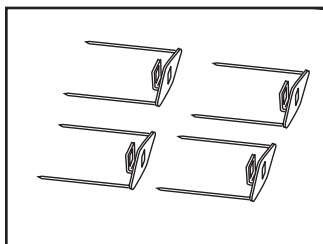

Suggested foods: Picnic roast, small to medium chicken, cornish hen, tenderloin, etc.

Introduction (Cont.)

Adjustable Basket

Use the Adjustable Basket to cook small cuts of meat, seafood, or vegetables. The Adjustable Basket has a Lid which can be raised or lowered to adjust to the thickness of the food. This keeps the food in place while it turns on the Rotisserie Bar.

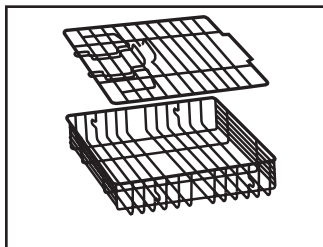

Suggested foods: Hamburgers, steaks, pork chops, fish, chicken breasts, sliced vegetables, etc.

Roasted Veggies/Air Bake Basket

The Roasted Veggies/Air Bake Basket is great for browning potatoes and vegetables. This Basket makes wonderful “guilt-free” air-baked fries. The extra large size means you can cook for the whole family in a single batch! An easy-close door keeps all the food in the Basket—safely and securely. This accessory is designed to be used with the Rotisserie Bar.

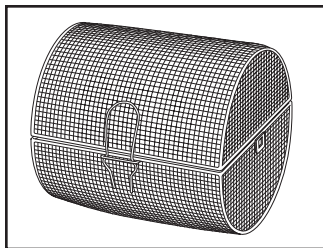

Suggested foods: Potatoes, frozen french fries, diced vegetables, etc.

Skewers

Five skewers means shish-kabobs for everyone! Combine your favorite meats and/or vegetables to create your favorite types.

Suggested foods: Beef, chicken, vegetables, etc.

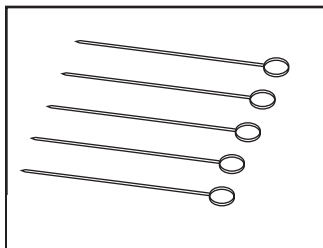

Introduction (Cont.)

Baking Sheet

The Baking Sheet lets you use your Rotisserie Oven like a regular baking oven. Use the Baking Sheet to bake your favorite items.

Suggested foods: For baking dinner rolls, cookies, etc.

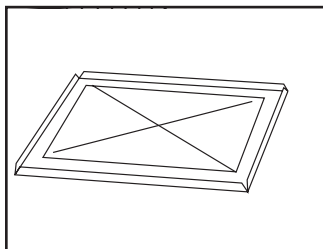

Wire Rack

The Wire Rack lets you use your Rotisserie Oven like a regular baking oven. The specially designed cross wires work with the skewers for evenly cooked shish-kabobs. You can even use this to cook a pizza!

When using the Wire Rack for baking, place into oven with cross wires down (on underside).

When using Wire Rack with Skewers, place Wire Rack into oven on lowest wire rack position with cross wires up (on topside)

Suggested foods: Frozen pizza, breads, pies, cakes, kabobs, etc.

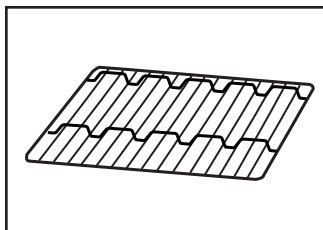

Preparing for Use

WARNING: Do not attempt to assemble parts inside the Rotisserie Oven while it is plugged in or hot. Burns or other serious injuries can occur.

Before Using Rotisserie Oven for the First Time

Before using your George Foreman Rotisserie Oven for the first time, wash all accessory parts with hot, soapy water. Rinse all parts well and dry thoroughly. Use a damp cloth or sponge to wipe down the inside and outside of the Rotisserie Oven. **CAUTION: Never immerse the Rotisserie Oven in water or any other liquid!**

Preparing for Use (Cont.)

Prepare Food

We recommend preparing the food to be cooked before proceeding with any cookware assembly. Cut all vegetables to be cooked or prepare a homemade marinade for extra flavor (see “Recipes” for information about Marinades and Rubs). If necessary, store food in refrigerator while preparing Rotisserie Oven.

Assembling the Rotisserie Bar

Before placing any items to be cooked onto the Rotisserie Bar, we suggest familiarizing yourself with how the Rotisserie Bar fits into the Rotisserie Oven and how each accessory works.

1. Locate the Rotisserie Bar.
2. WITHOUT TURNING THE ROTISSERIE OVEN ON YET, use the Cover Handles to lift open the Cover.
3. Angle the Rotisserie Bar so the **pointed end** fits into the center hole in the **right side** (when facing front of Rotisserie) of the Rotisserie Oven . See Figure 1.
4. Move the **square, “nut” end** of the Rotisserie Bar so it fits into the cut-out on the **left side** (when facing front of Rotisserie) of the Rotisserie Oven.

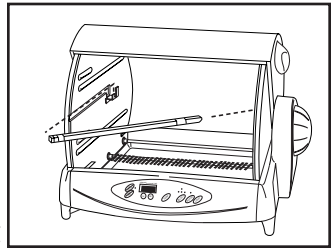

Figure 1

This is the correct position for assembling the Rotisserie Bar.

Assemble Drip Tray

1. If not in place, slide Drip Tray into position as shown in Figure 2.

NOTE: To limit any smoke which may occur as a result of dripping juices, add a small amount of water to the Drip Tray (just enough to cover bottom) before beginning cooking.

Adding water to the Drip Tray will also make clean-up easier!

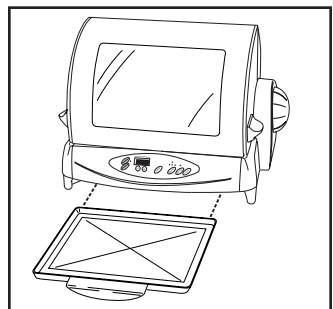

Figure 2

Preparing for Use (Cont.)

Assembling Accessories onto Rotisserie Bar

IMPORTANT: All foods must be secured onto Rotisserie Bar. Whenever possible, you must use the End Brackets to secure the accessory/food (Meat Tines, Adjustable Basket, Roasted Veggies/Air Bake Basket). However, when cooking extra-large cuts of meat or poultry, it may be necessary to eliminate the End Brackets to make more room on the Rotisserie Bar. In this case, you **MUST** use the 4-prong Meat Tines and the Wing Nuts (removed from End Brackets) to secure food into place on Rotisserie Bar. **When using 4-prong Meat Tines with EXTRA-LARGE CUTS OF MEAT, skip directly to the "4-Prong Meat Tines" section.**

NOTE: Always place accessories and meat/food onto Rotisserie Bar from the pointed end.

1. Determine whether you will use the 2-prong Meat Tines or the 4-prong Meat Tines (depending upon food/meat size). See Figure 4 and example turkey and chicken drawings on following pages. **When using 4-prong Meat Tines with EXTRA-LARGE CUTS OF MEAT, skip directly to the "4-Prong Meat Tines" section.** For all other Meat Tines, proceed with steps #2 and #3 below.

If you will be using the Roasted Veggies/Air Bake Basket, proceed with steps #2 and #3 below. **If you will be using the Adjustable Basket, skip to section "Preparing for Use - Adjustable Basket."**

2. If the Rotisserie Oven was previously used, be sure all parts have cooled and remove Rotisserie Bar from inside Rotisserie Oven.
 3. Locate two (2) End Brackets. Unscrew each wing nut fully, but do not remove from bracket. Place Brackets against each other so long ends are touching as shown in inset drawing. Set both End Brackets down while keeping them in the same position. (You will be assembling only the End Bracket shown on the left at this time.) Pick up End Bracket which is shown on the left and slide pointed end of Rotisserie Bar through the square hole in this End Bracket **ONLY**. See Figure 3.
- 3. DO NOT attach remaining End Bracket at this time.**

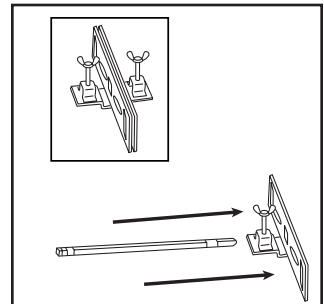

Figure 3

Preparing for Use (Cont.)

2-PRONG MEAT TINES

NOTE: Be sure to use two of the same type Meat Tines for each piece of meat you cook!

4. Locate square hole in center of each Meat Tine (the Rotisserie Bar fits through the square hole). Place first Meat Tine onto Rotisserie Bar so pointed ends point in the same direction as the pointed end of the Rotisserie Bar. Push Meat Tine against first End Bracket.

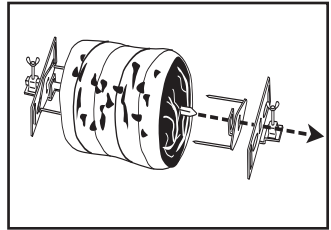
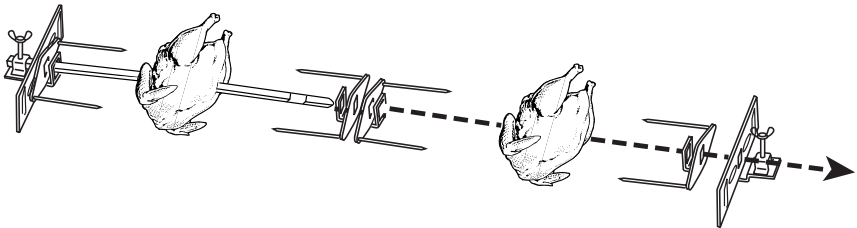

Figure 4

5. Pierce meat/food with Rotisserie Bar. Slide meat/food across Rotisserie Bar and into pointed ends of first Meat Tine.
6. Push matching Meat Tine onto Rotisserie Bar so pointed ends face "in" toward meat/food. While holding first Bracket, firmly push Meat Tine into food.
7. Push remaining Bracket onto Rotisserie Bar and against Meat Tine. See Figure 4.
8. Center food on Rotisserie Bar and push each End Bracket against Meat Tines. Tighten both wing nuts to secure all pieces in place.

Using 2-prong Meat Tines with two small chickens or cornish hens



Preparing for Use (Cont.)

4-PRONG MEAT TINES

For Extra-Large Cuts of Meat:

NOTE: Be sure to use two of the same type Meat Tines for each piece of meat you cook!

4. Locate square hole in center of each Meat Tine (the Rotisserie Bar fits through the square hole). Place first Meat Tine onto Rotisserie Bar so pointed ends point in the same direction as the pointed end of the Rotisserie Bar.
5. Unscrew and remove wing nut from each End Bracket. (NOTE: ONLY if you are NOT using End Brackets with 4-Prong Meat Tines!)
6. Pierce meat/food with Rotisserie Bar. Slide meat/food across Rotisserie Bar and into pointed ends of first Meat Tine.
7. Push matching Meat Tine onto Rotisserie Bar so pointed ends face "in" toward meat/food. While holding first Bracket, firmly push Meat Tine into food.
8. Once food is centered, insert wing nut into side hole in 4-prong Meat Tine as shown below. Tighten wing nut firmly until Meat Tines are secure on Rotisserie Bar.

Using 4-prong Meat Tines with an extra-large Turkey

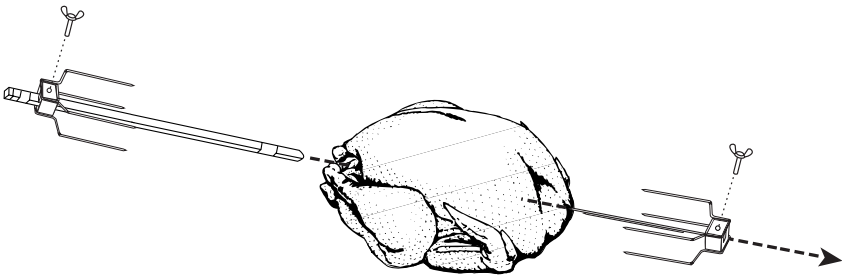

Preparing for Use (Cont.)

ROASTED VEGGIES/AIR BAKE BASKET

NOTE: Follow steps 2-3 under "Assembling Accessories onto Rotisserie Bar."

4. Grasp the wire handle on the Roasted Veggies/Air Bake Basket Door. Squeeze the wires and pull the door open. See Figure 5.
5. Place food into Basket. Be sure to allow room across the center for the Rotisserie Bar.
6. Close Basket Door.
7. Carefully slide Round Basket onto Rotisserie Bar and against first End Bracket.
8. Push remaining End Bracket onto Rotisserie Bar and against Round Basket. See Figure 6.
9. Center Basket on Rotisserie Bar and push each End Bracket against Basket. Tighten both wing nuts to secure all pieces in place.

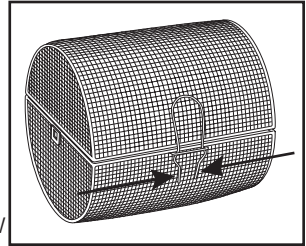

Figure 5

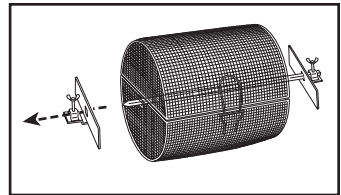

Figure 6

ADJUSTABLE BASKET

1. If the Rotisserie Oven was previously used, be sure all parts have cooled and remove Rotisserie Bar from inside Rotisserie Oven.
2. Grasp the wire handle on the Adjustable Basket. Pull the wire closest to the edge toward the other handle wire and lift up. Pull the "tab" end of the Basket Cover out of side wires and lift up to remove Cover. See Figure 7. Set Cover aside.
3. Place food into Basket. Be sure to allow room across the center for the Rotisserie Bar. Place food flat; do not "stack" food.

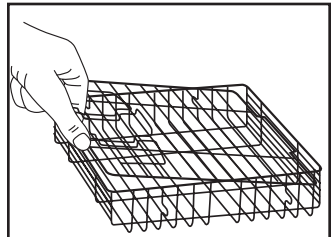

Figure 7

Preparing for Use (Cont.)

4. Replace Basket Cover so it fits **TIGHTLY** against food. (The Cover will "hold" the food in place as it turns on the Rotisserie Bar.) The cover can be adjusted up or down to accommodate the thickness of the food.
5. Locate looped wires on opposite sides of Adjustable Basket. Place an End Bracket over each set of looped wires (on both sides of Basket). The Brackets have cut-outs which fit over the looped wires. See Figure 6.
6. Carefully slide Rotisserie Bar (pointed end first) through square hole in End Bracket, through Basket, and through opposite End Bracket. See Figure 8.
7. Center Basket on Rotisserie Bar and push each End Bracket against Adjustable Basket. Tighten both wing nuts to secure all pieces in place.

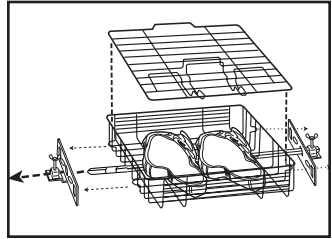

Figure 8

Using Baking Sheet

NOTE: Do not use the Baking Sheet at the same time as the Rotisserie Bar.

1. Use the Cover Handles to lift open the Cover.
2. The Baking Sheet can be used in the **middle position only**. See Figure 9. Slide Baking Sheet into Rotisserie Oven at middle level as shown. When using the Wire Rack for baking, be sure the two cross wires are on the bottom.

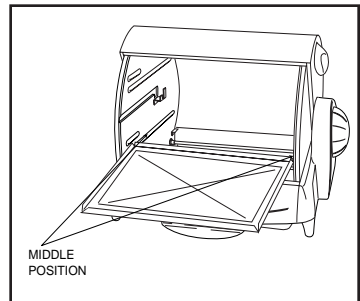

Figure 9

Using Wire Rack for Baking

NOTE: Do not use the Wire Rack at the same time as the Rotisserie Bar.

1. Use the Cover Handles to lift open the Cover.
2. The Wire Rack can be used in the **top middle, or bottom** positions. See Figure 10.

NOTE: These instructions are for using the Wire Rack for Baking. When using the Wire Rack with Skewers, see "Using Wire Rack with Skewers" below.

Place Wire Rack into Rotisserie Oven at desired level. Be sure the two cross wires are on the bottom.

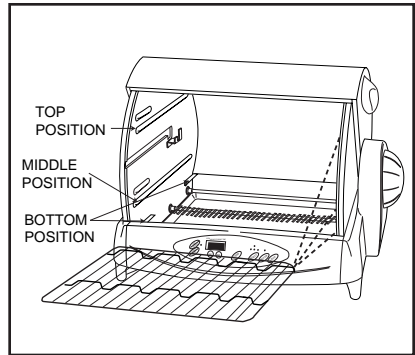

Figure 10

3. Use Cover Handles to close Cover.

Using Wire Rack with Skewers

NOTE: Use Skewers with the Wire Rack only. Do not attempt to use Skewers any other way.

1. Use the Cover Handles to lift open the Cover.
2. Hold Wire Rack upside down (so two cross wires are on top). Arrange Wire Rack so cross wire closest to end will go into the Rotisserie Oven first (it will be toward the back). Place Wire Rack into oven at **BOTTOM** position as shown in Figure 11. Be sure Rack is on both front and back parts of ledge.

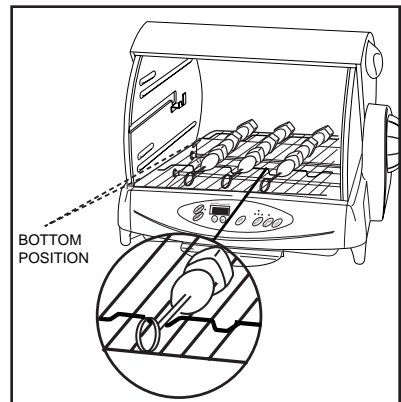

Figure 11

3. Cut food into 1 to 1-1/2 inch pieces. Slide food pieces onto pointed end of Skewer. Repeat for each desired skewer.
4. Place each Skewer into "dip" in cross wire as shown. The pointed end of the Skewer will "rest" on the back cross wire of the Wire Rack.
5. Use Cover Handles to close Cover.

Operation

NOTE: When using this product for the first time, you may notice a slight burning odor and a small amount of smoke. This is normal and will dissipate in a short amount of time.

1. Use Cover Handles to lift open Cover.
2. Prepare food, Rotisserie Oven, and accessories as instructed in "Preparing for Use." If using the Rotisserie Bar, follow the instructions in "Preparing for Use" under "Assembling the Rotisserie Bar" to install the fully assembled Rotisserie Bar into the Rotisserie Oven.
3. Be sure Drip Tray is in place (See "Preparing for Use.")
4. Plug the Rotisserie Oven into a standard, household electrical outlet.
5. The LCD Display will show: "0:00".

Once the Rotisserie Oven is plugged in, you may operate the Motor Button, the Light Button, or the Temperature ("TEMP") Button.

NOTE: The Rotisserie Oven cannot begin heating and the SELECT button cannot be activated until the Timer is set and the ON/PAUSE Button is pressed.

6. Press the Hour "H" Button to set the timer to the number of hours you wish to cook the food (1-5 hours).
7. Press the Minute "M" Button to set the minutes.
8. Once your complete cooking time is programmed and the Timer is set, press the ON/PAUSE button.

If the Motor was on the last time the machine turned off, the Motor will immediately start as the Rotisserie Oven turns on. If the Motor is on, a red LED will illuminate above the button and you will hear the motor turning the Rotisserie Bar.

If the Motor is off and you are using the Rotisserie Bar, press the Motor Button to turn the motor on. As the food rotates around, check that the food does not hit any of the Heating Elements. If you are using the Wire Rack or Baking Sheet, you do not need to turn on the Motor.

9. When the Rotisserie Oven turns on, it defaults to heating the front and back bottom Heating Elements (as represented by the LEDs above the Select button). See the instructions marked "Select Button" under the "Introduction" section of this manual for detailed information.

Press "SELECT" Button to choose which Heating Elements you will want to cook with. Each time you press the button, an additional Heating Element is added (first the center, bottom; then the top Heating Element)

Operation (Cont.)

until all Heating Elements are selected. Then, when you press the button, it will revert back to its default setting (front and back bottom Heating Elements).

- Press the "TEMP" Button to set the cooking temperature. The cooking temperature is indicated by small dots in the far left portion of the LCD Timer Display. There are six temperature settings. The following is a breakdown of the six temperature settings and the temperature ranges for each setting:

Symbol Temperature

•	225°F
••	300°F
•••	350°F

Symbol Temperature

••••	400°F
•••••	425°F
••••••	450°F

- Allow the food to cook (see "Cooking Chart" for more information).

To pause during a cooking cycle (to add more seasoning, for basting, or to adjust food), press the ON/PAUSE Button. The motor will stop turning and the red "ON" light will flash indicating that it is in pause mode. The Pause Mode will last 10 minutes. Make any necessary adjustments, then press the ON/PAUSE button again to resume the cooking cycle. If the ON/PAUSE button is not pressed within 10 minutes, the Rotisserie Oven will automatically resume the cooking cycle.

The food will cook only for as long as the Timer is set. When the time elapses, the entire Rotisserie Oven will turn off (even the Motor). Or, you may press OFF/RESET Button at any time to stop or change the cooking cycle.

- Once food is cooked, and the Rotisserie Oven is off, unplug the Rotisserie Oven from the outlet. Allow the cooked food to sit 15-20 minutes.

CAUTION: Always unplug Rotisserie before removing food. DO NOT carve meat while it is in the Rotisserie.

CAUTION: Always protect hands with oven mitts when handling hot Rotisserie parts or when removing food from Rotisserie Oven.

Operation (Cont.)

13. **Protect your hands with oven mitts** and remove Rotisserie Bar or other accessory from Rotisserie Oven.

To remove Rotisserie Bar: Hold Rotisserie Bar Remover by the handle with the hooks facing up. See Figure 11. Carefully slide the hooks under the cut-outs on the ends of the Rotisserie Bar.

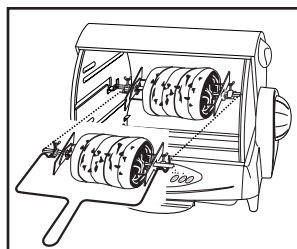

Figure 11

NOTE: When removing extra large cuts of meat or poultry, put on oven mitts and grasp each end of Rotisserie Bar. Carefully lift Rotisserie Bar up and out of Rotisserie Oven.

14. **Carefully** remove food from Rotisserie Bar and/or other accessory.

Cooking Chart

The following times are meant to be used as guidelines only. Times will vary due to the thickness of the meat being cooked. To be sure that a meat is truly done, use a meat thermometer. If the food does need more time to cook, reset the timer in 5-10 minute increments and check periodically so you do not over cook.

Food	Amount	Cook Temp. °F	Suggested Cook Time	Internal Temp.
POULTRY				
Chicken, whole	3-4 lbs.	350 ⋮	1 hr. 10 min. to 1 hr. 45 min.	175-180
Chicken, kebab	1" pieces	425 ⋮⋮	10-15 min.	175
Chicken breast, boneless	4 oz.	425 ⋮⋮	10-15 mn.	175
Rock Cornish Game hen, whole	1-1-1/4 lbs.	400 ⋮⋮	20-25 min.	160-165
Duck, whole	3-4-1/2 lbs.	400 ⋮⋮	1 hr. 20 min.	175-180
Turkey, whole*	up to 16 lbs.	350 ⋮	up to 4-1/2 hrs.	180
Turkey, breast with carcass	4-5 lbs.	350 ⋮	1 hr. 20-25 min.	170
BEEF				
Roast, trimmed and tied	3-4 lbs.	350 ⋮	Rare: 45 min. Medium: 1 hr. Well-done: 1 hr. 15 min.	140 160 170
Sirloin Steak	3/4" thick	450 ⋮⋮	Rare: 15 min. Medium: 20-25 mn. Well-done: 30-35 min.	140 160 170

* See instructions listed on poultry for cooking times per pound as they may differ from those listed here.

Cooking Chart (Cont.)

Food	Amount	Cook Temp. °F	Suggested Cook Time	Internal Temp.
Kabobs	1" pieces	450	25-30 min.	160
PORK				
Boneless, trimmed and tied	3-4 lbs.	350	1 hr. 15 min. to 1 hr. 45 min.	160
Tenderloin	1-1/2-2 lbs.	425	20 min.	160
LAMB				
Leg, boneless and tied	3-4 lbs.	350	1 hr.	145
Kabobs	1" pieces	400	20-25 min.	145
SEAFOOD				
Swordfish steak	3/4" thick	450	12-18 min.	
Swordfish kabobs	1" pieces	450	15-20 min.	
Salmon steak	3/4" thick	450	12-15 min.	
Shrimp, peeled	Extra Large	450	15-20 min.	

PLEASE NOTE: The USDA recommends that meats such as beef, pork, etc. should be cooked to an internal temperature of 160°F and poultry products should be cooked to an internal temperature of 165°F to be sure any harmful bacteria has been killed.

When re-heating meat/poultry products, they should also be cooked to an internal temperature of 160-165°F.

Hints and Tips

CAUTION: *Always protect hands with oven mitts when handling hot Rotisserie parts!*

- Do not place Rotisserie Oven underneath cabinets or on a tablecloth during use.
- Times given in Cooking Chart are suggestions. Cook meat to your own tastes.
- To limit any smoke which may occur as a result of dripping juices, add a small amount of water to the Drip Tray (just enough to cover bottom) before beginning cooking. Adding water to the Drip Tray will also make clean-up easier!
- Before beginning the full roasting process, press the Motor Button to let the machine rotate a few times with meat in place. Be sure the meat rotates freely and does not hit any of the Heating Elements when it rotates. (Although the Motor will turn when the Motor button is pressed, the Rotisserie Oven will not turn on unless the Timer is set.) If the meat does hit any of the Heating Elements, tie the food with cooking string or you may need to cut the meat down in size slightly.
- You may want to lightly oil the Rotisserie Bar and other accessories to prevent sticking.
- Do not cover food while it is cooking in the Rotisserie Oven.
- Do not attempt to cook food in the Rotisserie without the Cover in place.
- Use the Oven light only as necessary to check the status of the cooking food. Do not use the light continuously during cooking as this will greatly reduce the life of the bulb.
- When cooking fatty foods (duck, turkey, etc.), check Drip Tray often to be sure the drippings do not overflow.
- When food is done roasting, let it sit for 15-20 minutes to let the cooking process complete and to allow the juices to settle before carving.
- Always unplug the Rotisserie Oven before removing the food.
- Make sure to use oven mitts or hot pads when removing the Rotisserie Bar with (or without) the Rotisserie Bar Remover.

User Maintenance Instructions

WARNING: Do not attempt to disassemble or clean the unit while it is plugged in and/or hot. Burns or other serious injuries can occur.

Your George Foreman Rotisserie Oven requires little maintenance. It contains no user-serviceable parts inside the Rotisserie Oven. Contact consumer service if the product requires servicing.

CAUTION: Press "OFF/Reset" button, unplug appliance from wall outlet, and allow all parts to cool completely before cleaning.

CAUTION: Do not use scouring pads or harsh or abrasive cleansers to clean the parts of the Rotisserie Oven. If necessary, use a nylon bristle brush to loosen hardened food particles.

1. Once product is unplugged and has cooled completely, carefully pull out Drip Tray. Use care not to spill any liquids as they may still be hot.
2. Remove all accessories from Rotisserie Oven. Wash all accessories in hot, soapy water. Rinse thoroughly and dry well.
3. Wipe outside of Rotisserie Oven with a damp cloth or sponge. Dry with a soft cloth.
4. Lift open (or remove) Cover. (See below to remove Cover for easy cleaning). Use a damp sponge to wipe the interior of the Rotisserie Oven. **Do not use scouring pads or harsh or abrasive cleansers to clean inside the Rotisserie Oven.** Dry all parts thoroughly.

To remove Rotisserie Oven Cover:

WARNING: Do not attempt to disassemble or clean the unit while it is plugged in and/or hot. Burns or other serious injuries can occur.

1. Locate two Spring-loaded Hooks on the sides of the Cover.
2. Firmly pull up on the Hooks while pulling Cover forward. See Figure 12. The Cover should release from the Rotisserie Oven Body.
3. Wash Cover in hot, soapy water. Use care not to scratch or break the Viewing Window.

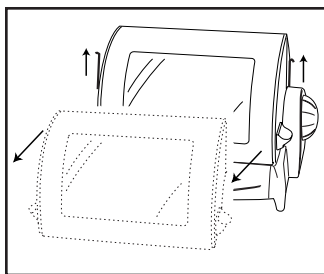

Figure 12

To replace Rotisserie Oven Cover:

1. Hold Cover in front of Rotisserie Oven.
2. Firmly pull up on the Hooks and slide Cover back into place on Rotisserie Oven Body.
3. Rotate Cover upwards to be sure it is in place properly.

User Maintenance Instructions (Cont.)

Replacing the Oven Light Bulb:

Your George Foreman Rotisserie Oven uses a long-lasting bulb for the oven light. However, if the light burns out, you can order replacement bulbs. When using the Oven Light in your Rotisserie Oven, we recommend using the light only as necessary to check the status of the cooking food. Do not use the light continuously during cooking as this will greatly reduce the life of the bulb.

You may order replacement bulbs by calling our Consumer Department toll free at 1-800-233-9054, email us at salton@saltonusa.com or write to:

Salton, Inc., 550 Business Center Drive, Mt. Prospect, Illinois 60056

WARNING: Do not attempt to disassemble or clean the unit while it is plugged in and/or hot. Doing so could cause an electrical hazard.

1. Unplug Rotisserie Oven from outlet and allow to cool completely.
2. Locate light bulb compartment on inside of Rotisserie Oven (along inside front panel).

3. Use a dime in slot of screw "A" to twist and remove screw. (Screw "A" is the only screw with a "slotted" head as shown in Figure 13.) Also, remove Glass Cover Bracket.

4. Carefully push Glass Cover all the toward the right (away from screws). Place your index finger into Finger Indent and carefully lift Glass Cover out. See Figure 14.

Carefully set Glass Cover aside.

4. Unscrew, remove, and discard old light bulb.
5. Screw in new light bulb.
6. Replace Glass Cover. Be sure Glass Cover fits between the ledge and the two small tabs as shown in Figure 14.

7. Align hole in Glass Cover Bracket over hole in metal rim and secure with Screw "A."

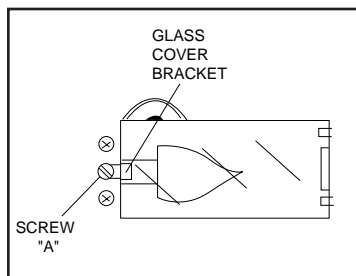

Figure 13

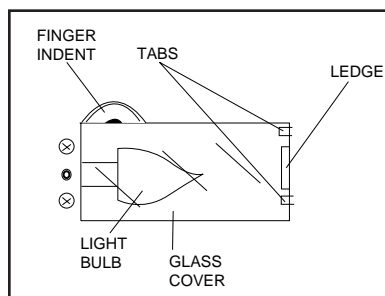

Figure 14

Recipes

A Little About Marinades and Rubs

Marinades tenderize, add flavor and moisten all kinds of foods. To keep beef, fish and chicken flavorful and juicy, a marinade is crucial.

There are three basic ingredients in most marinades. Acids (vinegar, citrus, wine, etc.), oils and spices. The acids tenderize, the oils moisten, and the spices add the flavor.

The amount of time a food marinates depends on the flavor and texture of that food. For example, fish should only marinate for up to 30 minutes or less, while a steak should marinate for a couple of hours or more.

While foods are marinating, they should be kept refrigerated. It is best to remove the food and bring back to room temperature before cooking. **NOTE:** Do not allow raw or uncooked meats to stand at room temperature for extended periods of time.

Extra flavor can be added to meats by rubbing with your choice of spices and herbs. This is called a dry rub. Before cooking, rub the food with spice and herb mixture and it is ready to cook. Common examples of spice rubs are cracked peppercorn, garlic, or rosemary.

Beef Marinade

1-1/2-2 cups each: water and dry red wine

8-10 black peppercorns (cracked)

6-8 cloves garlic (whole)

1 red onion (sliced)

1 Tablespoon dry rosemary

- Mix ingredients together and pour over desired meat portion. Allow to marinate overnight turning from time to time.
- This marinade is the best for most kinds of meat including venison and tougher cuts of meat.

Marinade Recipes

Lamb Marinade* (up to a 3 lb. lamb)

3/4 cup dried apricots (chopped)
2 large red onions(sliced)
2 cloves garlic (minced)
1 Tablespoons butter
1-1/2 Tablespoons curry powder
1-1/2 Tablespoons sugar
4 Tablespoons apple cider vinegar
3/4 teaspoon salt
pinch of paprika and cayenne pepper
2-3 bay leaves

- Soak chopped apricots overnight.
 - The next day, soak them until they are tender
 - Pureé in blender.
 - Sauté onions and garlic in butter until golden. After a couple of minutes, add curry.
 - Add the apricot pureé, sugar, salt, vinegar, cayenne and paprika. Bring entire mixture to a boil, then remove from heat.
 - Pour over lamb and marinate overnight.
- * NOTE: This is a thick marinade.

Fish Marinade

1/3 cup pineapple juice
3 teaspoons soy sauce
3 teaspoons lemon juice
2 garlic cloves (minced)

- Mix the above ingredients and pour over fish fillets.
- Let marinate for a maximum of 30 minutes.
- Cook in Adjustable Basket for 5-10 minutes at 450°.

Marinade Recipes (Cont.)

Chicken Marinade (up to a 5-6 lb. chicken)

1/3 cup cooking oil
3/4 cup dry white wine
2 garlic cloves (minced)
1 medium onion (finely chopped)
1/3 teaspoon salt
1/2 teaspoon pepper
1/3 teaspoon dried rosemary or thyme

- Mix the above ingredients well and pour over the chicken. Let marinate for 3 hours.
- Cook on the Rotisserie Bar with Meat Tines for 1 hr. and 30 minutes to 2 hours at 350°.

Pork Marinade (up to a 1 lb. of pork chops)

2 Tablespoons chili sauce
1-1/3 Tablespoons lemon juice
2 Tablespoons grated onion
1/3 teaspoon dry mustard
3 teaspoons Worcestershire sauce
Dash salt, pepper and paprika
1/2" thick chops.

- Mix above ingredients well and pour over chops. Marinate chilled for up to 3 hours.
- Cook in Adjustable Basket for 20-25 minutes at 450°.

Rubs*

Any spice or herb can be used for a dry rub on virtually any kind of meat: roasts, chicken, steaks, and fish. These, of course, are just suggestions. The possibilities for rubs are endless...

Here are some examples:

Red Meat Rub

1 Tablespoon cracked peppercorn
2-4 Tablespoons salt
2-4 garlic cloves (chopped or minced)
1 Tablespoon rosemary
1 Tablespoon paprika

Fish Rub

1 Tablespoon dried basil
1 teaspoon salt
1 teaspoon pepper
pinch paprika

Chicken Rub

1 Tablespoon pepper or cracked peppercorn
2-4 Tablespoons salt
1/2 Tablespoon tarragon

*Measurements will vary due to sizes of the meat. As a rule, use 1-2 Tablespoons of rub ingredients per pound of food. For a 6 lb. chicken, use up to 12 Tablespoons of spices.

Herbed Roasted Chicken (5-6 lb. chicken)

Herb Rub

2-3 Tablespoons dried rosemary
1 Tablespoon peppercorns
2-4 Tablespoons salt
2 Tablespoons thyme (dried)
2-3 Tablespoons dried parsley
1 5-6 lb. chicken

- Clean out the inside cavity of the chicken. Remove skin if desired.
- Pat the surface dry with a paper towel.
- Combine all of the rub ingredients.
- Rub the ingredients onto the surface of the chicken.
- Place the chicken on Rotisserie Bar with Meat Tines.
- Tie cooking string around chicken to hold in legs so they do not touch the Heating Element in the Rotisserie.
- Place chicken onto the Rotisserie Bar with Meat Tines.
- Set Timer for 1-1/2-2 hours and Temperature for 350°.
- Close Rotisserie Oven Cover.
- Cooking will begin when Start/Pause button is pressed.

Honey Pineapple Pork Roast

Marinade

1/4 cup tamari or light soy sauce
1/4 cup white vinegar
1/4 cup extra virgin olive oil
1/4 cup fresh or canned (packed in juice) crushed pineapple
2 Tablespoons honey
2 Tablespoons finely chopped ginger
2 garlic cloves (finely chopped)
1 3-4 lb. Pork Roast

- Soak a 3-4 lb. boneless, trimmed and tied pork roast in marinade for 4 hours.
- Place on Rotisserie Bar with Meat Tines. Set Timer for 1 hour and 15 minutes to 1 hour and 45 minutes and temperature for 350°.
- Close Rotisserie Oven Cover.
- Cooking will begin when Start/Pause button is pressed.
- You may want to use drippings for basting during the last 45 minutes of cooking. Baste periodically every 10-15 minutes.

Skewered Lamb Kabobs

Marinade

1/2 cup olive oil

1-1/2 Tablespoon dried rosemary

3 cloves garlic, crushed 1/2 teaspoon salt

Kabobs

1-1/2 lbs. boneless lamb,

4-6 large mushrooms

2 small green zucchini cut into 1" squares

2 ripe plum tomatoes

- Stir marinade ingredients together in a large bowl.
- Add the lamb squares, zucchini, tomatoes and mushrooms to the marinade and toss until all is well coated.
- Let stand covered loosely stirring occasionally. Keep refrigerated.
- Add ingredients to skewers in the following order: Zucchini chunk, lamb square, mushroom, lamb square, tomato, lamb square, zucchini.
- Place Wire Rack into position (on lowest wire rack position and cross wires facing up) and place Skewers onto Rack. Set Timer for 20-25 minutes at 450°F.
- Close Rotisserie Oven Cover.
- Cooking will begin when Start/Pause button is pressed.

“Guilt-free” Air Baked Fries

1-1 1/2 lbs. potatoes (washed)

cut into 1/2" cubes or cut into 1/2" strips (steak fries)

- Place cut potatoes into Roasted Veggies/Air Bake Basket.
- Secure Basket onto Rotisserie Bar with Brackets. Cook at 450°F for 30 minutes.
- After 30 minutes, press “ON/PAUSE” button.
- Use Rotisserie Bar Remover to remove Rotisserie Bar and Basket. Use oven mitts to open Basket Door and add seasoning to taste (salt, garlic, rosemary, etc.). (If desired, you may spray a light mist of olive oil onto potatoes before seasoning. DO NOT spray olive oil into Rotisserie Oven.) Turn Basket to coat evenly with seasoning.
- Use oven mitts to replace Rotisserie Bar with Basket into Rotisserie Oven.
- Close Rotisserie Oven Cover.
- Press ON/PAUSE Button and cook for an additional 15 minutes.

ONE-YEAR LIMITED WARRANTY

This Salton, Inc. product warranty extends to the original consumer purchaser of the product.

Warranty Duration: This product is warranted to the original consumer purchaser for a period of one (1) year from the original purchase date.

Warranty Coverage: This product is warranted against defective materials or workmanship. This warranty is void if the product has been damaged by accident, in shipment, unreasonable use, misuse, neglect, improper service, commercial use, repairs by unauthorized personnel or other causes not arising out of defects in materials or workmanship. This warranty is effective only if the product is purchased and operated in the USA, and does not extend to any units which have been used in violation of written instructions furnished by Salton, Inc., or to units which have been altered or modified or to damage to products or parts thereof which have had the serial number removed, altered, defaced or rendered illegible.

Warranty Disclaimers: This warranty is in lieu of all warranties expressed or implied and no representative or person is authorized to assume for Salton, Inc. any other liability in connection with the sale of our products. There shall be no claims for defects or failure under any theory of tort, contract or commercial law including, but not limited to negligence, gross negligence, strict liability, breach of warranty and breach of contract.

Warranty Performance: During the above one-year warranty period, a product with a defect will be either repaired or replaced with a reconditioned comparable model (at Salton, Inc. option) when the product is returned to the Salton, Inc. facility. The repaired or replacement product will be in warranty for the balance of the one-year warranty period and an additional one-month period. No charge will be made for such repair or replacement.

Service and Repair

Should the appliance malfunction, you should first call toll-free 1-800-233-9054 **between the hours of 8:00 am and 5:00 pm Central Standard Time** and ask for **CONSUMER SERVICE** stating that you are a consumer with a problem. Please refer to Model #GR80 when you call.

In-Warranty Service: For an appliance covered under the warranty period, no charge is made for service or postage. Call Consumer Service at the above number for return authorization.

Out-of-Warranty Service: A flat rate charge by model is made for Out-of-Warranty service. Please include \$15.00 (U.S.) for return shipping and handling.

Salton, Inc. cannot assume responsibility for loss or damage during incoming shipment. For your protection, carefully package the product for shipment and insure it with the carrier. Be sure to enclose the following items with your appliance: any accessories related to your problem; your full name and return address and daytime phone number; a note describing your problem, a copy of your sales receipt or other proof of purchase to determine warranty status. C.O.D. shipments cannot be accepted.

Return the appliance to:

ATTN: Repair Department
Salton, Inc.
708 South Missouri St. Macon, MO 63552

For more information on Salton, Inc. products visit our website:

<http://www.salton-maxim.com>, or you can E-Mail us at: salton@saltonusa.com