

Installation Instructions / Warranty

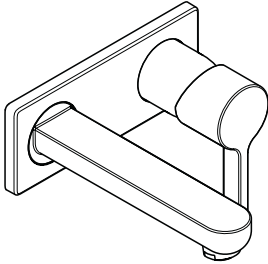

Metris S
31163xx1

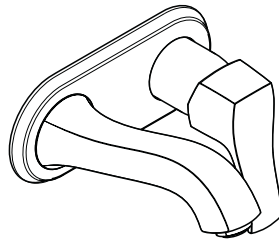

Metris C
31003xx1

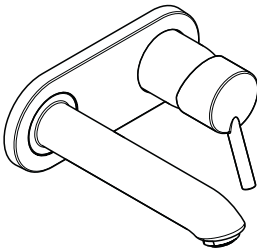

Talis S
31611xx1

hansgrohe

Metris C 31003xx1

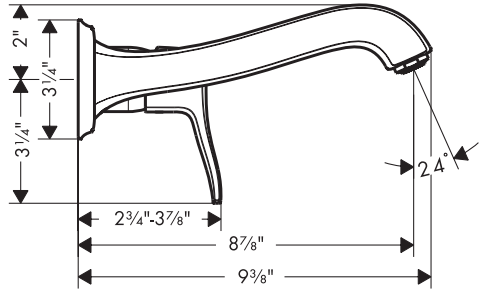
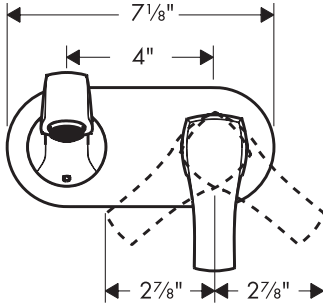

Metris S 31163xx1

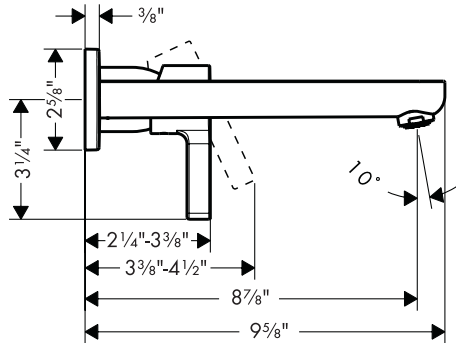
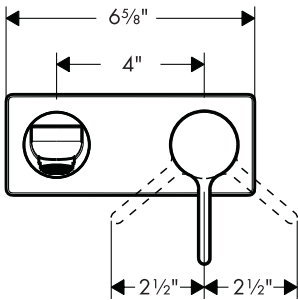

Talis S 31611xx1

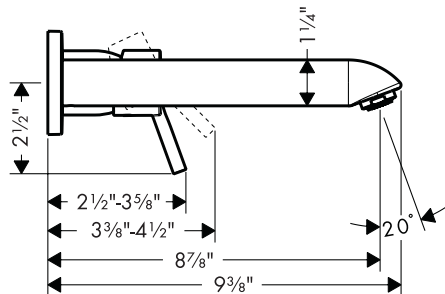
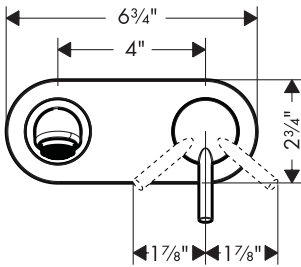

Technical Information / Données techniques / Datos técnicos

Recommended water pressure	Pression d'eau recommandée	Presión recomendada en servicio	15 - 75 psi
Max. water pressure	Pression d'eau maximum	Presión en servicio max.	145 psi
Recommended hot water temp.	Température recommandée d'eau chaude	Temperatura recomendada del agua caliente	120° - 140° F*
Max. hot water temp	Température maximum d'eau chaude	Temperatura del agua caliente max.	176° F*
Flow rate	Capacité nominale	Caudal máximo	1.5 gpm

*Please know and follow all applicable local plumbing codes when setting the temperature on the water heater.

* Vous devez connaître et respecter tous les codes de plomberie locaux applicables pour le réglage de la température du chauffe-eau.

*Debe conocer y cumplir todos los códigos locales aplicables para ajustar la temperatura del calentador de agua.

Installation Considerations

- For best results, Hansgrohe recommends that this unit be installed by a licensed, professional plumber.
- Please read over these instructions thoroughly before beginning installation. Make sure that you have all tools and supplies needed to complete the installation.
- This trim kit is for use only with rough valve 13622181 (not included).
- Keep this booklet and the receipt (or other proof of date and place of purchase) for this product in a safe place. The receipt is required should it be necessary to request warranty parts.

À prendre en considération pour l'installation

- Pour de meilleurs résultats, Hansgrohe recommande que ce produit soit installé par un plombier professionnel licencié.
- Veuillez lire attentivement ces instructions avant de procéder à l'installation. **Assurez-vous de** disposer de tous les outils et du matériel nécessaires pour l'installation.
- Conservez ce livret et le reçu (ou une autre preuve sur laquelle figurent la date et l'endroit de l'achat) pour ce produit dans un endroit sûr. Le reçu est requis si vous commandez des pièces sous garantie.

Consideraciones para la instalación

- Para obtener mejores resultados, la instalación debe estar a cargo de un plomero profesional matriculado.
- Antes de comenzar la instalación, lea estas instrucciones detenidamente. Asegúrese de tener las herramientas y los insumos necesarios para completar la instalación.
- Mantenga este folleto y el recibo (u otro comprobante del lugar y fecha de compra) de este producto en lugar seguro. El recibo se requiere en caso de ser necesario solicitar piezas bajo garantía.

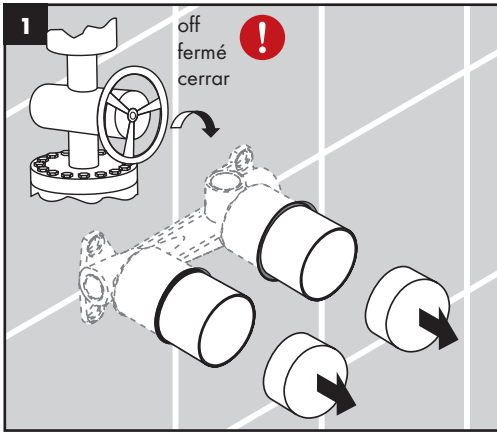

Installation

! Turn off the water at the main before beginning!

Remove the covers.

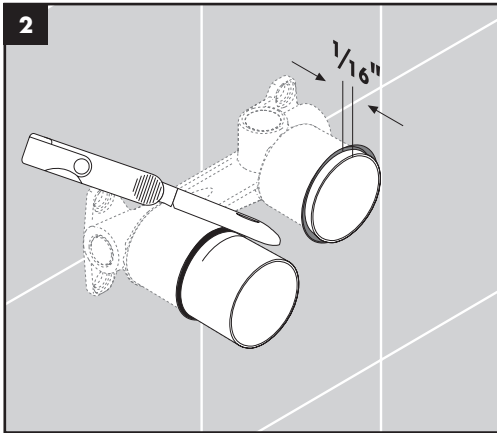

Cut the plaster shields so that they extend $\frac{1}{16}''$ outside the surface of the finished wall.

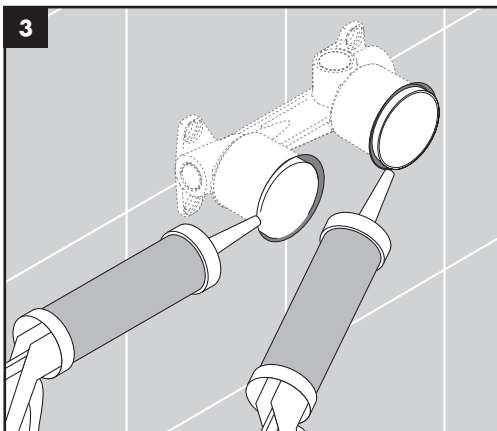

! Seal the wall around the i-box with waterproof sealant.

! Failure to seal the wall can lead to possible water damage.

Installation



Avant de commencer, fermez l'eau à la valve principale.

Retirez les capuchons.

Coupez les protecteurs de façon à ce qu'une partie de $\frac{1}{16}$ po soit à l'extérieur de la surface du mur fini.



Scellez le mur autour des protecteurs à l'aide d'un agent d'étanchéité.



Si le mur n'est pas scellé, l'eau pourrait éventuellement causer des dommages.

Instalación



Cierre el paso del agua en la entrada del suministro antes de comenzar.

Retire las tapas.

Corte los protectores de yeso de modo que sobresalgan $\frac{1}{16}$ " de la superficie de la pared terminada.



Selle la pared alrededor del protector de yeso con un sellador impermeable.



Si no se sella la pared, pueden producirse daños por acción del agua.

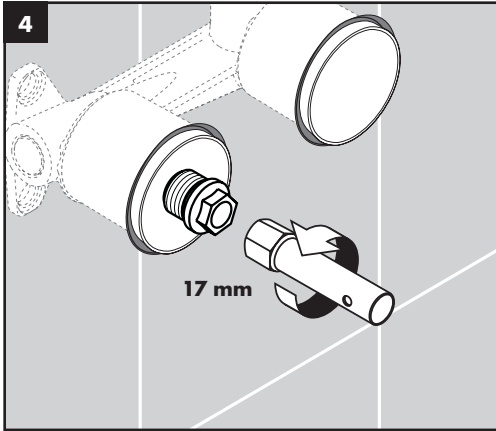

Remove the bolt using a 17 mm socket wrench.

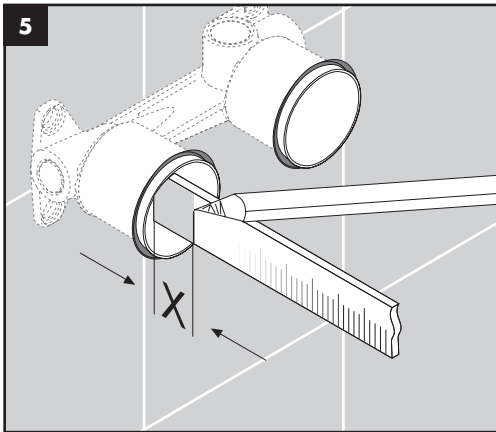

Measure the distance from the rough to the outside of the plaster shield ("X").

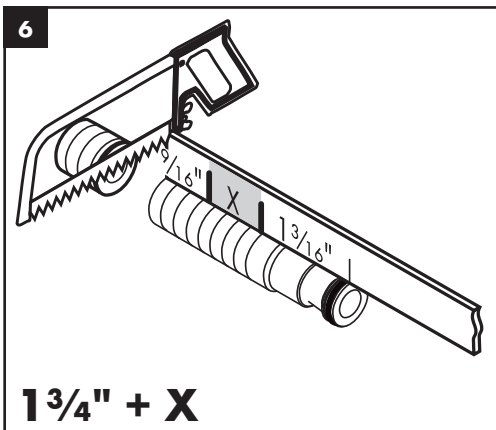

Add $1\frac{3}{4}''$ to X.

Cut the threaded end of the nipple so that the nipple measures $1\frac{3}{4}'' + X$.

Français

Retirez le bouchon du port de bec de remplissage.

Mesurez la distance entre la surface de la pièce du port de bec de remplissage et le rebord extérieur du protecteur (« X »).

Ajoutez $1\frac{3}{4}$ po à la mesure « X ».

Coupez le raccord fileté de façon à ce qu'il mesure « X » + $1\frac{3}{4}$ po de long.

Español

Retire el tapón del orificio del surtidor.

Mida la distancia desde la superficie de la parte interna del orificio del surtidor hasta el borde externo del protector de yeso ("X").

Agregue $1\frac{3}{4}$ " mm a X.

Corte el niple roscado para que tenga X + $1\frac{3}{4}$ " de largo.

Wrap the threads on the nipple using Teflon tape.

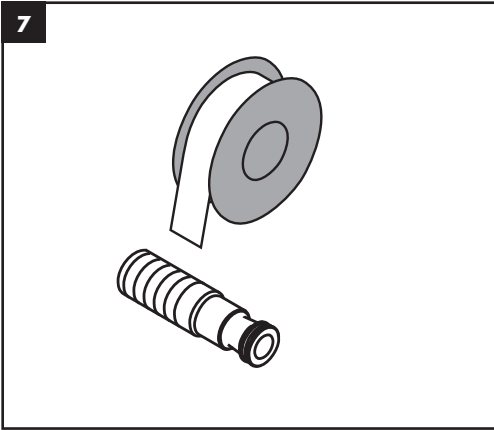

Install the nipple on the rough. Tighten the nipple using an 8 mm Allen wrench.

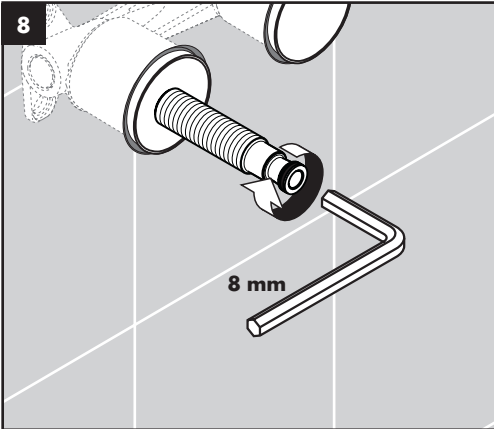

The nipple should extend 1" - 1 1/8" from the surface of the finished wall.

Use a 17 mm socket wrench to remove the bolt from the handle side of the rough.

Remove the nut, flush insert, and sealing ring.

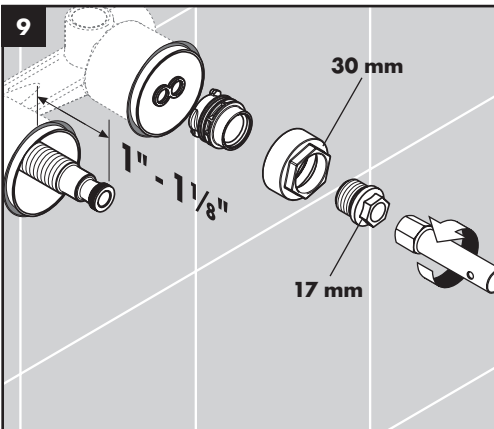

Français

Enveloppez les filets sur le raccord fileté avec du ruban Téflon.

Installez le raccord fileté.

Serrez le raccord fileté à l'aide d'une clé hexagonale de 8 mm.

Le raccord devrait étendre 1 po - 1 1/8 po de la surface du mur fini.

Retirez le bouchon du port de cartouche.

Retirez l'écrou, le compartiment affleurant et la bague d'étanchéité du port de cartouche.

Español

Envuelva las roscas del niple con cinta de Teflon.

Instale el niple.

Apriete el niple con una llave Allen de 8 mm.

El niple deberá extender 1" - 1 1/8" po de la superficie de la pared acabada.

Quite el tapón del orificio del cartucho.

Retire la tuerca, el alojamiento de descarga y el anillo de sellado del orificio del cartucho.

English

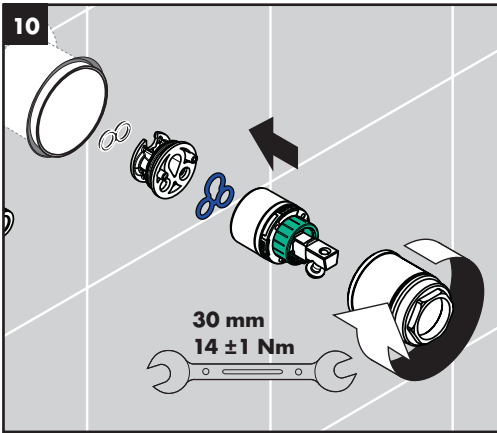

Install the sealing ring, cartridge adapter, and cartridge.

Install the cartridge nut. Tighten it using a 30 mm wrench to 14 Nm.

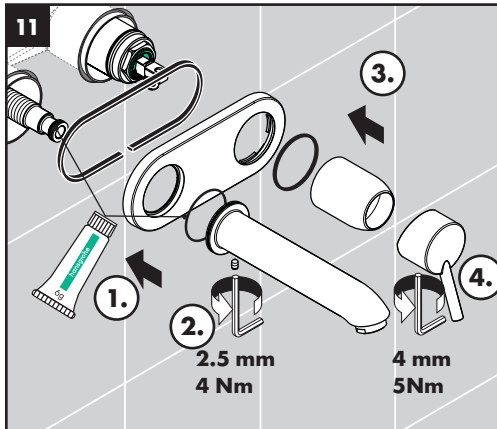

Install the sealing ring and escutcheon (1).

Install the spout. Tighten the screw using a 2.5 mm Allen wrench (2).

Install the sealing ring and sleeve (3).

Install the handle. Tighten the screw using a 4 mm Allen wrench.

Do not overtighten the screw.

Français

Installez l'adaptateur dans le port de cartouche.

Installez la cartouche.

Installez l'écrou.

Serrez l'écrou à l'aide d'une clé de 30 mm.

Installez la plaque de base (1).

Poussez le bec de remplissage en place sur le raccord fileté.

Serrez la vis du bec de remplissage à l'aide d'une clé hexagonale de 2.5 mm (2).

Installez la bride (3).

Installez la poignée (4).

Serrez la vis de la poignée à l'aide d'une clé hexagonale de 4 mm.

Español

Instale el adaptador en el orificio del cartucho.

Instale el cartucho.

Instale la tuerca del cartucho.

Coloque la tuerca con una llave de 30 mm.

Instale la placa de base (1).

Coloque el surtidor en su lugar sobre el niple.

Apriete el surtidor con una llave Allen de 2.5 mm (2).

Instale la brida (3).

Instale la manija (4).

Apriete el tornillo de la manija con una llave Allen de 4 mm.

Set the High Temperature Limit Stop (optional)

Lift the handle (1).

Use a 4 mm Allen wrench to push the screw cover into the handle (2).

Use the 4mm Allen wrench to loosen the handle screw 4 complete revolutions (3).

Remove the handle (4).

Retrieve the screw cover.

Remove the nut cover.

Turn the stem counter-clockwise.

Remove the handle screw (1).

Remove the high temperature limit stop (2).

Replace the high temperature limit stop so that the pin on the cartridge is in the desired slot on the limit stop.

Note: the temperatures given in the diagram assume a water heater temperature of 140° F, a cold water temperature of 50° F and a water pressure of 45 PSI.

Replace the nut cover (1).

Replace the handle screw. Use the Allen wrench to turn the screw 4 revolutions (2).

Replace the handle (1). Tighten the handle screw (2).

Install the screw cover (3).

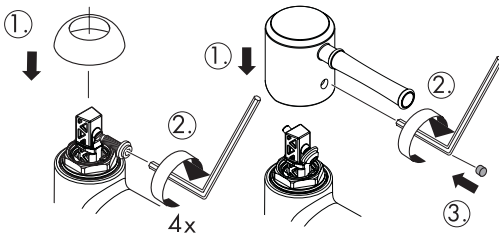
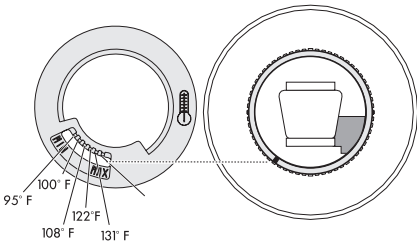
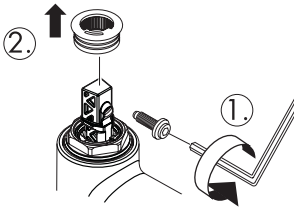
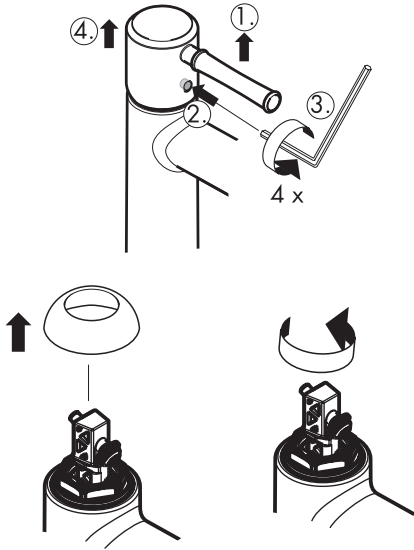

Réglage de la butée limite d'eau chaude (en option)

Poussez le cache-vis dans la poignée à l'aide d'une clé hexagonale de 4 mm (2).

Desserrez la vis de la poignée (4 tours complets) (3).

Enlevez la poignée (4) et retirez le cache-vis.

Enlevez le capot sphérique.

Retirez la vis de la poignée (1).

Enlevez la butée limite d'eau chaude (2).

Remettez en place la butée limite d'eau chaude de sorte que l'onglet de la cartouche soit dans la fente voulue de la butée.

Avis: Les températures indiquées sur le schéma présupposent que la température du chauffe-eau est réglée à 140° F pour l'eau chaude et à 50° F pour l'eau froide, à raison d'une pression d'arrivée d'eau de 45 psi.

Remettez le capot sphérique en place (1).

Réinstallez la vis de la poignée (2). Serrez la vis (4 tours complets).

Remettez la poignée en place (1). Serrez la vis (2). Installez le cache-vis (3).

Ouvrez l'eau et vérifiez le robinet.

Ajuste el tope de límite de alta temperatura (opcional)

Levante el mando (1).

Utilice una llave inglesa de 4 mm Allen para empujar la cobertura de tornillo en el mando (2).

Utilice la llave inglesa de 4 mm Allen para aflojar el tornillo de mando 4 revoluciones completas (3).

Quite el mando (4).

Recupere la cobertura de tornillo. Quite la cobertura de tuerca.

Gire el tallo a la izquierda.

Quite el tornillo de mando (1).

Quite el tope de límite de alta temperatura (2).

Reemplace la parada alta de límite de temperatura para que el alfiler en el cartucho estén en la ranura deseada en la parada de límite.

La nota: Las temperaturas se rindieron el esquema asume una temperatura de calentador de 140° F, una temperatura de agua fría de 50° F y una presión del agua de 45 PSI.

Reemplace la cobertura de tuerca (1).

Reemplace el tornillo de mando. Utilice la llave inglesa de Allen para girar el tornillo 4 revoluciones (2).

Reemplace el mando (1).

Apriete el tornillo de mando (2).

Instale la cobertura de tornillo (3).

Replacement Parts / Pièces détachées / Repuestos

Talis S 31611xx1

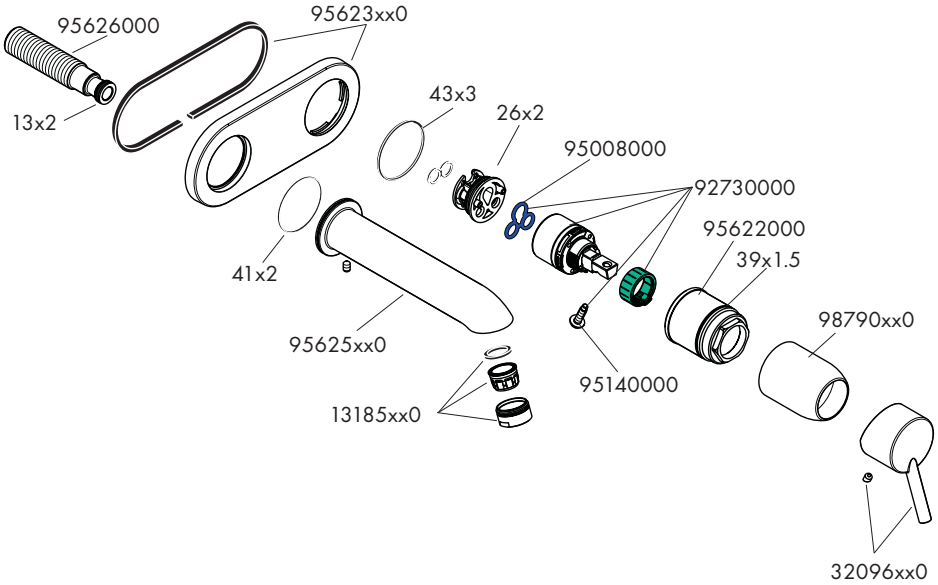

Metris C 31003xx1

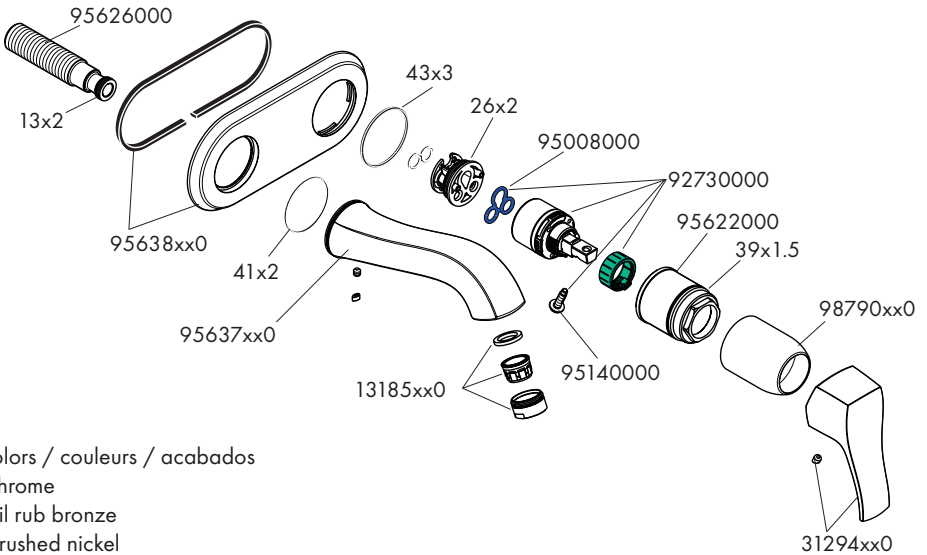

xx = colors / couleurs / acabados
 00 = chrome
 62 = oil rub bronze
 82 = brushed nickel
 83 = polished nickel
 92 = rubbed bronze

Metris S 31163xx1

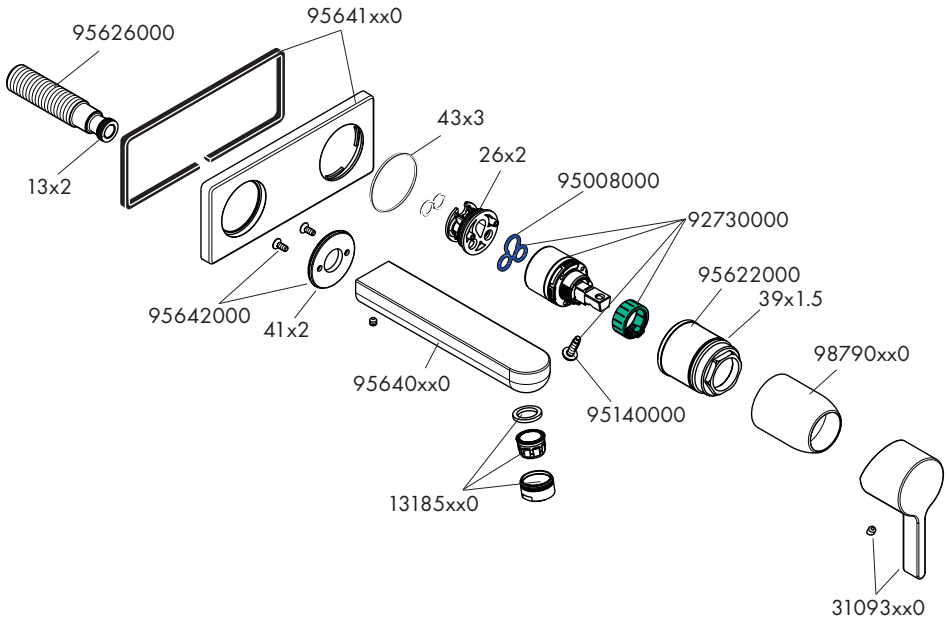

Extension / Rallonge / Prolongación

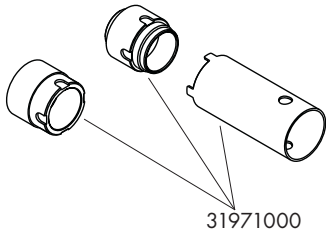

User Instructions / Instructions de service / Manejo

on
ouvert
abierto

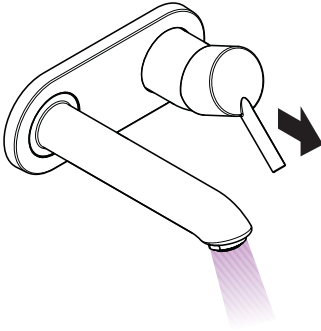

off
fermé
cerrar

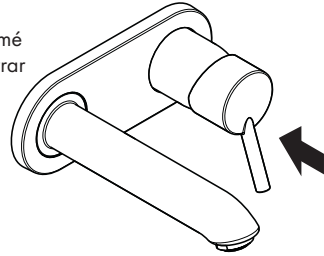

cold
froid
frío

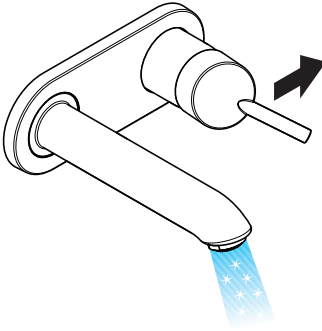

hot
chaud
caliente

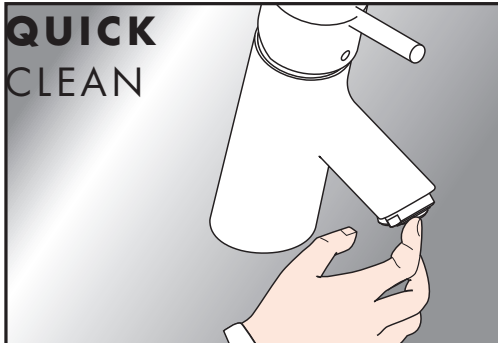
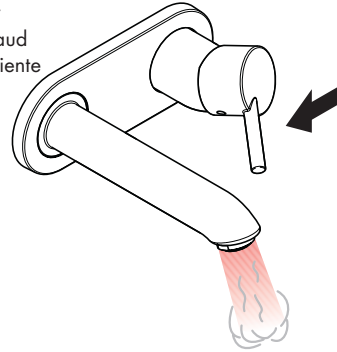

- The aerator uses the QuickClean cleaning function. A brief manual rub over the spray channels removes lime scale deposits.
- L'aérateur est équipée de QuickClean, le système anticalcaire manuel. Les dépôts de calcaire s'enlèvent en frottant avec un doigt ou avec une éponge sur les ouvertures de jets élastiques.
- QuickClean, la función de limpieza manual, permite quitar la cal simplemente frotando los ejectores.

Cleaning Recommendation for Hansgrohe Products

Modern lavatory faucets, kitchen faucets, and showers consist of very different materials to comply with the needs of the market with regard to design and functionality. To avoid damage and returns, it is necessary to consider certain criteria when cleaning.

Cleaning Materials for Faucets and Showers

Acids are a necessary ingredient of cleaning materials for removing lime, however please pay attention to the following points when cleaning faucets and showers:

- Only use cleaning materials which are explicitly intended for this type of application.
- Never use cleaning materials which contain hydrochloric, formic, phosphoric, or acetic acid, as they cause considerable damage.
- Never mix one cleaning material with another.
- Never use cleaning materials or appliances with an abrasive effect, such as unsuitable cleaning powders, sponge pads, or micro fiber cloths.

Cleaning Instructions for Faucets and Showers

Please follow the cleaning material manufacturer's instructions. In addition, pay attention to the following points:

- Clean the faucets and showers as and when required
- Use the amount of cleaning product and the amount of time recommended by the manufacturer. Do not leave the cleaner on the fixture longer than necessary.
- Regular cleaning can prevent calcification.
- When using spray cleaners, spray first onto a soft cloth or sponge. Never spray directly onto the faucet as droplets can enter openings and gaps and cause damage.
- After cleaning, rinse thoroughly with clean water to remove any cleaner residue.

Important

Residues of liquid soaps, shampoos, and shower foams can also cause damage, so rinse with clean water after using.

Please note: if the surface is already damaged, the effect of cleaning materials will cause further damage.

Components with damaged surfaces must be replaced or injury could result.

Damage caused by improper treatment is not covered under the warranty.

Recommandations pour le nettoyage des produits Hansgrohe

Les robinetteries modernes de lavabo, de cuisine et de douche utilisent des matériaux très différents pour répondre aux besoins du marché en termes de conception et de fonctionnalité. **Certaines règles de base doivent être respectées lors du nettoyage de ces produits afin d'éviter de les endommager ou d'avoir à les retourner.**

Produits de nettoyage pour robinetteries et douches

Les acides sont une partie intégrante nécessaire de tous les produits de détartrage; il faut cependant prendre les précautions suivantes lors du nettoyage des robinets et des douches :

- N'utilisez que des produits/articles de nettoyage conçus spécifiquement pour les articles de robinetterie et de douche.
- N'utilisez jamais de produits/articles de nettoyage contenant de l'acide chlorhydrique, formique, phosphorique ou acétique car ils pourraient causer des dommages considérables.
- Ne mélangez jamais deux produits de nettoyage.
- N'utilisez jamais de produits/articles de nettoyage de nature abrasive tels que poudres de nettoyage, tampons-éponge ou chiffons microfibre non appropriés.

Instructions de nettoyage pour robinetteries et douches

Veillez suivre les instructions du fabricant de produits/articles de nettoyage. **De plus, tenez compte des conseils suivants :**

Nettoyez vos produits de robinetterie et de douche aussi souvent que nécessaire.

- Utilisez la quantité de produit nettoyant et respectez la durée recommandée par le fabricant. **Ne laissez pas le produit sur les articles de robinetterie plus longtemps que nécessaire.**
- Un nettoyage régulier peut prévenir la formation de dépôts calcaires.
- Si vous utilisez des nettoyeurs en vaporisateur, vaporisez d'abord sur une éponge ou un chiffon. **Ne vaporisez jamais directement sur un robinet** : des gouttelettes pourraient s'infiltrer dans les ouvertures et les interstices et endommager celui-ci.
- Après le nettoyage, rincez abondamment avec de l'eau propre pour éliminer tout résidu de produit nettoyant.

Important

Les résidus de savon liquide, de shampooing et de mousse pour la douche peuvent également endommager la robinetterie; rincez donc avec de l'eau propre après utilisation de ces produits.

Veillez noter : si la surface est déjà endommagée, les produits de nettoyage l'endommageront encore plus.

Les composants dont la surface est endommagée devraient être remplacés sous peine d'entraîner des blessures.

Les dommages dus à un mauvais traitement ne sont pas couverts par la garantie.

Recomendación de limpieza para los productos de Hansgrohe

Hoy en día, las griferías de baño y de cocina así como duchas modernas se componen de materiales muy distintos para satisfacer las exigencias del mercado respecto al diseño y la funcionalidad. Para evitar daños reclamaciones hay que tener en cuenta ciertos aspectos tanto en el uso como en su limpieza posterior.

Para elucidado de las griferías y las duchas en principio hay que seguir lo siguiente:

- Usar sólo detergentes previstos específicamente para este campo de aplicación.
- No aplicar detergentes que contengan hipoclorito sódico, ácido clorhídrico, fórmico o acético porque pueden causar daños importantes.
- Detergentes que contienen ácido fosfórico tampoco pueden ser aplicados ilimitadamente.
- Por regla general no se deben mezclar detergentes.
- Tampoco se deben utilizar utensilios abrasivos, como son polvos abrasivos, esponjas o paños de microfibra.
- Si tienen que seguir siempre las instrucciones de uso de los fabricantes de los detergentes.
- La limpieza tiene que ser realizada según la dosificación y el tiempo de actuación, en función del objeto y ajustada a las necesidades específicas del mismo.
- Gracias a una limpieza periódica se pueden evitar las incrustaciones de cal.
- No conviene rociar el detergente en ningún caso sobre la grifería sino sobre los textiles y ejecutar la limpieza así porque el líquido puede entra en aperturas o hendiduras de la grifería y causar daños.
- Después de la limpieza hay que aclarar con suficiente agua para eliminar completamente el resto de detergente.
- La utilización de limpiadores a vapor no está permitida, las altas temperaturas pueden dañar los productos.

Indicaciones importantes

Los residuos de productos de aseo como jabón líquido, champús y gel de ducha pueden dañar también los materiales.

Por lo que también se deberá prestar atención a lo siguiente: aclarar con abundante agua después del uso.

Con materiales ya dañados la acción de detergentes incrementará el desgaste de estos.

Los componentes con superficies dañadas deberán cambiarse, en otro caso se corre el peligro de lesionarse.

Los daños que resulten de un uso inadecuado no están incluidos en nuestra garantía.

Limited Consumer Warranty

This product has been manufactured and tested to the highest quality standards by Hansgrohe, Inc. ("Hansgrohe"). This warranty is limited to Hansgrohe products that are purchased by a consumer in the United States or Canada after March 1, 1996, and installed in either in the United States or in Canada.

WHO IS COVERED BY THE WARRANTY

This warranty extends to the original purchaser only. This warranty is non-transferable.

WHAT IS COVERED BY THE WARRANTY

The warranty covers only your Hansgrohe manufactured product. Hansgrohe warrants this product against defects in material or workmanship as follows:

Hansgrohe will replace at no charge for parts only or, at its option, replace any product or part of the product that proves defective because of improper workmanship and/or material, under normal installation, use, service and maintenance. If Hansgrohe is unable to provide a replacement and repair is not practical or cannot be made in timely fashion, Hansgrohe may elect to refund the purchase price in exchange for the return of the product.

LENGTH OF WARRANTY

Replacement or repaired parts of products will be covered for the term of this warranty, as stated in the following two sentences. If you are a consumer who purchased the product for use primarily for personal, family or household purposes, this warranty extends for as long as you own the product and the home in which the product is originally installed. If you purchased the product for use primarily for any other purpose, including, without limitation, a commercial purpose, this warranty extends only (i) for 1 year, with respect to Hansgrohe & Commercial products, and (ii) for 5 years, with respect to Axor products.

THIS WARRANTY DOES NOT COVER, AND HANSGROHE WILL NOT PAY FOR:

- A. Conditions, malfunctions or damage not resulting from defects in material or workmanship.
- B. Conditions, malfunctions or damage resulting from (1) normal wear and tear, improper installation, improper maintenance, misuse, abuse, negligence, accident or alteration; (2) the use of abrasive or caustic cleaning agents or "no-rinse" cleaning products, or the use of the product in any manner contrary to the product instructions; or (3) conditions in the home such as excessive water pressure or corrosion.
- C. Labor and other expenses for disconnection, deinstallation, or return of the product for warranty service (including but not limited to proper packaging and shipping costs), or for installation or reinstallation of the product.
- D. Accessories, connected materials and products, or related products not manufactured by Hansgrohe.
- E. Any Hansgrohe or Axor product sold for display purposes.
- F. Rubbed Bronze finish is subject to a 3-year limited warranty. Chrome and all PVD finishes are covered by the limited lifetime warranty.
- G. Hansgrohe Water Filtration System is subject to a 1-year limited warranty. Warranty does not include replacement filters.

TO OBTAIN WARRANTY PARTS OR INFORMATION

Contact your Hansgrohe retailer, or contact Technical Service at:

Hansgrohe, Inc.
1492 Bluegrass Lakes Parkway
Alpharetta, GA 30004
Toll-free 800-334-0455

In requesting warranty service, you will need to provide:

1. The sales receipt or other evidence of the date and place of purchase.
2. A description of the problem.
3. Delivery of the product or the defective part, postage prepaid and carefully packed and insured, to:

Hansgrohe, Inc.
1492 Bluegrass Lakes Parkway
Alpharetta, GA 30004
Toll-free 800-334-0455

When warranty service is completed, any repaired or replacement product or part will be returned to you postage prepaid.

EXCLUSIONS AND LIMITATIONS

REPAIR OR REPLACEMENT (OR, IN LIMITED CIRCUMSTANCES, REFUND OF THE PURCHASE PRICE) AS PROVIDED UNDER THIS WARRANTY IS THE EXCLUSIVE REMEDY OF THE PURCHASER. HANSGROHE NEITHER ASSUMES NOR AUTHORIZES ANY PERSON TO CREATE FOR IT ANY OTHER OBLIGATION OR LIABILITY IN CONNECTION WITH THIS PRODUCT. HANSGROHE SHALL NOT BE LIABLE TO PURCHASER OR ANY OTHER PERSON FOR ANY INCIDENTAL, SPECIAL OR CONSEQUENTIAL DAMAGES, ARISING OUT OF BREACH OF THIS WARRANTY OR ANY IMPLIED WARRANTY (INCLUDING BUT NOT LIMITED TO ANY IMPLIED WARRANTY OF MERCHANTABILITY).

Some States do not allow the exclusion or limitation of incidental or consequential damages, so the above limitation or exclusion may not apply to you. This warranty gives you specific legal rights, and you may also have other rights that vary from state to state.

TO THE EXTENT PERMITTED BY LAW, ANY IMPLIED WARRANTIES OF MERCHANTABILITY AND FITNESS FOR A PARTICULAR PURPOSE, ARE LIMITED TO THE DURATION OF THE EXPRESS WARRANTY.

Some states do not allow limitations on how long an implied warranty may last, so the above limitations may not apply to you. You may be required by law to give us a reasonable opportunity to correct or cure any failure to comply before you can bring any action in court against us under the Magnuson-Moss Warranty Act.

PRODUCT INSTRUCTIONS AND QUESTIONS

Upon purchase or prior to installation, please carefully inspect your Hansgrohe product for any damage or visible defect. Prior to installing, always carefully study the enclosed instructions on the proper installation and the care and maintenance of this product. If you have questions at any time about the use, installation or performance of your Hansgrohe product, or this warranty, please write us or call us toll-free at 800-334-0455.

hansgrohe

Hansgrohe, Inc. • 1490 Bluegrass Lakes Parkway • Alpharetta, GA 30004
Tel. 770-360-9880 • Fax 770-360-9887

www.hansgrohe-usa.com