

Operation Guide PDM-10B/20B

ILLUSTRATION

PDM-10B

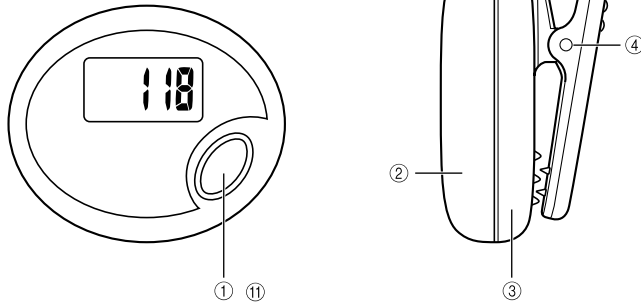

PDM-20B

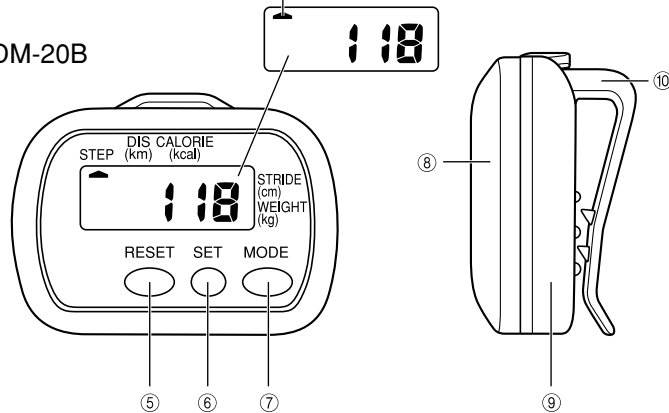

- A sticker is affixed to the glass of the pedometer when you purchase it. Be sure to remove the sticker before using the pedometer.
- Depending on the model of your pedometer, its configuration may differ somewhat from that shown in the illustration.

GENERAL GUIDE

PDM-10B

- ① **RESET button**
Press to reset the number of steps to "0". Pressing this button while the display is blank turns on the display. Holding down this button turns off power.

② **Front cover**

③ **Back cover**

④ **Clip**

PDM-20B

- ⑤ **RESET button**
Press to reset the number of steps to "0".

⑥ **SET button**

⑦ **MODE button**

⑧ **Front panel**

⑨ **Back panel**

⑩ **Clip**

⑪ **Cursor**

OPENING THE PEDOMETER PANELS (PDM-20B)

Holding the front and back panels of the pedometer, release the catch on the top of the panels and then open them as shown in the illustration.

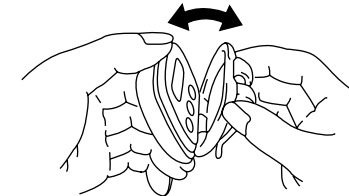

AFFIXING THE PEDOMETER TO YOUR CLOTHING

- Clip the pedometer securely to your belt or the waistband of your slacks, skirt, training pants, etc.
- Take care that you hook the clip so your belt or waistband enters the clip as far as it will go. Improper attachment of the pedometer or wearing it an angle can cause mistakes in the number of step count.
- Take care that you do not accidentally press the **RESET button** while you are attaching or removing the pedometer. Accidentally pressing the **RESET button** will reset the number of steps to "0".
- Make sure that the two panels of the pedometer are securely closed while you are using it (PDM-20B).

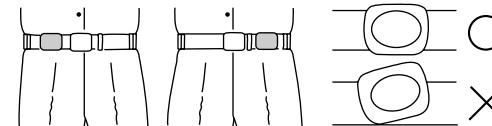

Operation Guide PDM-10B/20B

CASIO®

HOW THE PEDOMETER WORKS

- This pedometer is intended for use while walking during normal daily life and during light jogging.
- As you walk or jog across a level surface, the pedometer detects the impact acceleration generated when your foot hits the ground.
- If you hold the pedometer vertically and shake it up and down, you should be able to hear a rattling sound. This is the sound of the pendulum inside the pedometer that is used for detecting movement. This sound indicates that the pedometer is operating normally.
- Note that the pedometer cannot count steps correctly under the conditions described below. Avoid these conditions whenever using the pedometer.

1. Irregular walking
 - Walking where it is crowded
 - Walking in sandals
 - Shuffling your feet
2. Any activity other than walking or jogging
 - Any activity that requires sudden standing or sitting
 - Jumping, or extreme activities or sports
 - Climbing or descending stairs or a steep slope
 - Vibration while riding on a car, train, bus, etc.

* Never start on any exercise program without consulting your physician, especially if you are currently under the care of a physician, or if you have any past history of heart problems.

CHANGING MODES (PDM-20B)

- Press the **MODE** button to cycle through the number of steps, distance, and calorie screens.

TO SET YOUR STRIDE LENGTH (PDM-20B)

1. Calculate your average stride length.
 - In a safe place, mark your starting point. Walk normally for 10 paces, and mark where you stop. Measure the distance between the two marks, and then divide by 10.

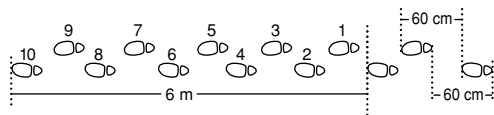

2. While the number of steps screen is displayed, press the **MODE** button once to display the distance screen.
3. Press the **SET** button to display the stride length setting screen.
4. While the stride length setting screen is on the display, use the **SET** button to specify the average stride length you calculated in step 1.
 - Each press of the **SET** button increases the displayed stride length by 1 cm. You can set a value in the range of 30cm to 180cm.
 - Holding down the **SET** button changes the setting at high speed.
 - The display will exit the stride length setting screen automatically if you do not perform any operation for a few seconds.
5. After you are finished setting the stride length you want, simply wait and the pedometer will automatically exit the stride length setting screen and return to the distance screen.

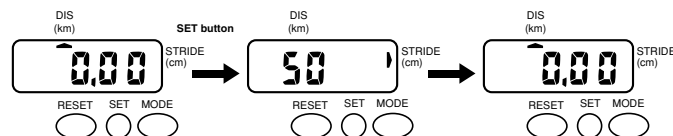

TO SET YOUR CURRENT WEIGHT (PDM-20B)

1. While the number of steps screen is displayed, press the **MODE** button twice to display the calorie screen.
2. Press the **SET** button to display the weight setting screen.
3. While the weight screen is on the display, use the **SET** button to specify your current weight.
 - The display will exit the weight length setting screen automatically if you do not perform any operation for a few seconds.
 - Each press of the **SET** button increases the displayed weight by 1 kg. You can set a value in the range of 30 kg to 120 kg.
 - Holding down the **SET** button changes the setting at high speed.
4. After you are finished setting your weight, simply wait and the pedometer will automatically exit the weight setting screen and return to the calorie screen.



RESETTING THE PEDOMETER

(PDM-10B)

Press the **RESET** button to reset the number of steps to "0".

(PDM-20B)

Press the **RESET** button to reset the number of steps, distance, and calories to "0".

Note that the **RESET** operation does not affect the stride length and weight settings.

- Before starting a new pedometer measurement operation, be sure to reset to "0" first.

BATTERY REPLACEMENT

Replace the battery whenever the figures on the display become dim and difficult to read.

Replacing the Battery

(PDM-10B)

1. Remove the screws that secure the back cover in place.
2. Remove the old battery.
3. Load a new battery so its positive (+) side is facing up (so you can see it).
 - Loading the battery improperly can cause it to leak and damage the interior of the pedometer.
4. Replace the back cover and secure it in place with the screws.

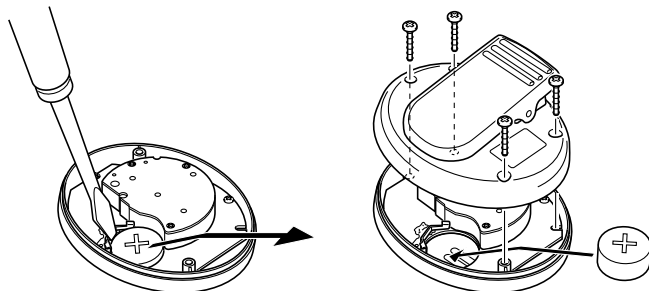

(PDM-20B)

1. Insert a coin or similar object into the slot on the bottom of the pedometer.
2. Move the coin up and down to remove the cover from the front panel.
3. Remove the old battery.
4. Load a new battery so its positive (+) side is facing up (so you can see it).
 - Loading the battery improperly can cause it to leak and damage the interior of the pedometer.
5. Replace the cover on the front panel.
 - Insert the tabs of the cover into the slots, and then press the cover until it snaps securely in place.
 - Check to make sure that the front panel cover is securely and properly in place.

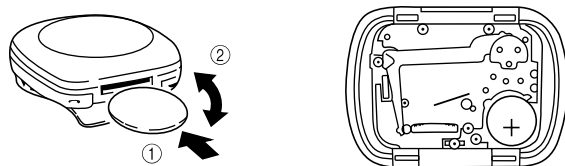

6. Hold down the **RESET**, **SET**, and **MODE** buttons at the same time for about three seconds until everything clears from the display.
7. Release the buttons.
 - This causes "8888" to appear for about two second, and then the number of step screen appears.
 - At this time the number of steps, distance, and calorie screens will all be "0".
 - The stride length and weight values are also reset to their initial defaults at this time. Perform the required procedures to re-specify your stride length and weight.

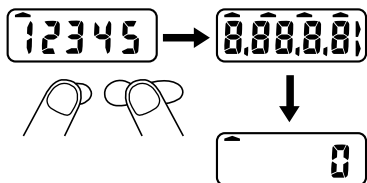

Battery Precautions

- Keep batteries out of the reach of small children. If a battery is accidentally swallowed, contact your physician immediately.
- Be sure to load the battery with its positive (+) side facing upwards (so you can see it).
- Never charge the battery that comes with the pedometer.
- Should the battery ever leak inside the pedometer, wipe out the fluid with a cloth, taking care not to let any get onto your skin.
- Replace the battery at least once every 3 years, even if the current battery is working properly.
- The battery that comes with the pedometer loses some of its power during transport and storage.