



9800 Martel Road
Lenoir City, TN 37772

PAV80

High-fidelity Audio-Video
In-Flight Entertainment System
With DVD/MP3/CD Player
and Radio Receiver



STC-PMA

Document P/N 200-800-0101

Revision 5

February 2004

Installation and Operation Manual

In certified aircraft, warranty is not valid unless this product is installed by an Authorized PS Engineering dealer.

PS Engineering, Inc. 2004 ©
Copyright Notice

Any reproduction or retransmittal of this publication, or any portion thereof, without the expressed written permission of PS Engineering, Inc. is strictly prohibited. For further information contact the Publications Manager at PS Engineering, Inc., 9800 Martel Road, Lenoir City, TN 37772. Phone (865) 988-9800.

Table of Contents

SECTION I GENERAL INFORMATION	1-1
1.1 INTRODUCTION	1-1
1.2 SCOPE	1-1
1.3 EQUIPMENT DESCRIPTION	1-1
1.4 APPROVAL BASIS (PENDING)	1-1
1.5 SPECIFICATIONS	1-2
1.6 EQUIPMENT SUPPLIED	1-3
OPTIONAL EQUIPMENT	1-4
PVA802 INSTALLATION KIT (250-802-0100)	1-4
1.7 EQUIPMENT REQUIRED BUT NOT SUPPLIED	1-4
1.8 APPROVED AUDIO SYSTEMS	1-5
1.9 LICENSE REQUIREMENTS	1-5
SECTION II - INSTALLATION	2-1
2.1 GENERAL INFORMATION	2-1
2.1.1 SCOPE	2-1
2.2 UNPACKING AND PRELIMINARY INSPECTION	2-1
2.3 EQUIPMENT INSTALLATION PROCEDURES	2-1
2.3.1 COOLING REQUIREMENTS	2-1
2.3.2 MOUNTING REQUIREMENTS	2-1
2.3.3 MOUNTING RACK INSTALLATION	2-2
2.3.4 CONNECTOR ASSEMBLY	2-3
2.4 CABLE HARNESS WIRING	2-4
2.4.1 NOISE	2-4
2.4.2 POWER.....	2-5
2.4.3 BACKLIGHTING	2-5
2.4.4 ANTENNA	2-5
2.4.5 AUX ENTERTAINMENT AUDIO AND AUX ENABLE.....	2-6
2.5 UNIT INSTALLATION	2-6
2.6 PVT801 DISPLAY INSTALLATION:	2-6
2.7 OPTIONAL PVA802 VIDEO DISTRIBUTION AMPLIFIER INSTALLATION	2-6
2.8 INTERNAL ADJUSTMENTS	2-7
2.9 POST INSTALLATION CHECKOUT	2-7
2.9.1 SYSTEM CHECKOUT	2-7
2.10 FINAL INSPECTION	2-8
SECTION III OPERATION	3-1
3.1 SCOPE	3-1
3.2 OPERATING CONTROLS	3-1
3.2.1 POWER/VOLUME CONTROL (1).....	3-1
3.2.2 ▲ STOP/EJECT BUTTON (2)	3-1
3.2.3 ► PLAY/PAUSE BUTTON (3)	3-1
3.2.4 THE ►► BUTTON (4)	3-2
3.2.5 THE MODE KNOB (5).....	3-2
3.2.6 THE ◀◀ BUTTON (6)	3-2
3.3 DISPLAY OPERATION	3-3
3.4 REMOTE OPERATION	3-4

3.5 DISPLAY DIMMING (7)..... 3-5

SECTION IV- WARRANTY AND SERVICE..... 4-1

4.1 WARRANTY 4-1

4.2 FACTORY SERVICE 4-1

APPENDIX A – MP3 CREATION A

5.1 CREATING MP3S FROM AN AUDIO CD..... A

APPENDIX B – INSTALLATION DRAWINGS B

APPENDIX C CONNECTOR INTERCONNECT..... C

7.1 SINGLE DISPLAY SYSTEM..... C

APPENDIX D- STC INFORMATION AND INSTRUCTIONS FOR CONTINUING AIRWORTHINESS D

8.1 INSTRUCTIONS FOR FAA FORM 337, PAV80s..... D

8.2 INSTRUCTIONS FOR CONTINUING AIRWORTHINESS, PAV80S D

8.3 MASTER DRAWING LIST D

APPENDIX E RTCA DO160D/EUROCAE ED-14D ENVIRONMENTAL QUALIFICATION FORM..... D

Table of Figures

Figure 2-2 Avionics Mounting Rails (Typical)..... 2-2

Figure 2-3 Completed panel opening (Typical) 2-3

Figure 2-4 Completed panel installation 2-3

Figure 2-5 -Tray Assembly 2-4

Figure 2-8 View of typical PVA802 Installation 2-7

Figure 3-1 Front Panel Controls..... 3-1

Figure 3-3- Remote Control (not to scale) 3-4

Figure 6-1 Panel Location Drawing (Typical) 120-800-8801..... B

Figure 6-2 PAV80 Installation Diagram (Typical) 120-800-2488..... C

Figure 6-3 Tray Installation Drawing, 002-973-0430 D

Figure 6-4 Display connector layout..... E

Figure 6-5 - PVT801 Monitor Dimension Details E

Figure 6-6 PVT801 Mounting Tray Dimensions (if used)..... F

Figure 6-7 Circuit breaker installation drawing 120-800-8802 (typical) G

Figure 6-8 PVA802 Video Distribution Amplifier Installation (Dwg. 120-802-0100) H

Figure 6-9 PVA802 Connector viewed from cable side H

Rev	Date	Change
1		1 st Release
2	Sept 03	STC Release
3	Nov 03	Remove installation angle restriction
4	Jan 04	Add information on portable display mount
5	Feb 04	Add restriction to use ONLY PS Displays on display power

Section I GENERAL INFORMATION

1.1 INTRODUCTION

Quality cockpit and cabin entertainment has long been an elusive dream in general aviation. From marginal performance to unapproved parts, pilots couldn't enjoy the same entertainment in their aircraft as they could in the family car.

The PAV80-Series represents such a product. This system combines a Digital Versatile Disc (DVD) player with CD and MP3 capability with an AM/FM radio for ultimate in-flight entertainment capability.

Before installing and/or using this product, please read this manual completely. This will ensure that you will take full advantage of all the advanced features in the PAV80.

1.2 SCOPE

This manual provides detailed installation and operation instructions for the PS Engineering PAV80-series of IFE Systems. This includes the following units:

Model	Part Number	Description
PAV80	050-800-0100	Integrated DVD-IFE System with CD/MP3/AM/FM
PAV80	050-800-0200	European Version Tuner
PVT801	050-801-0100	5.6" LCD Video Display
Remote	051-803-0150	IR Remote Control
PVA802	050-802-0100	Remote Video Distribution Amplifier

Where the functions are identical to all units, it will be referred to herein as a PAV80. Otherwise, the applicable units will be specified.

1.3 EQUIPMENT DESCRIPTION

The PAV80 System is a single panel mounted unit that contains a DVD player with MP3 media capability and an AM/FM radio receiver. It also contains a high-fidelity stereo amplifier to provide the entertainment output to the aircraft audio system. A single LCD monitor (PVT801) is included in the system. Up to four external video displays can provide visual entertainment to the passengers, with the optional video distribution amplifier (PVA802).

An 8-digit LED display provides information about the systems modes and media in use. A remote control is used for passenger control over the system.

1.4 APPROVAL BASIS

The PAV80 is FAA approved FAA-STC SA02707AT and manufactured under PMA. PQ1336CE.

All systems comply with relevant portions of EUROCAE ED-14D/DO-160D (*Environmental Conditions and Test Procedures for Airborne Equipment*), ED12B/DO-178B (*Software Considerations for Airborne Equipment*) and ED- 18/DO-214 (*Audio Systems Characteristics and Minimum Operational Performance Standards for Aircraft Audio Systems*).

STC SAAT can be used as a basis for approval in other aircraft provided the generic installation manual, Document Number 200-800-0002 or later approved revision, is followed.

Advisory Circulars AC43.13-1B Acceptable Methods, Techniques, and Practices - Aircraft Inspection and Repair, and 43.13-2A - Acceptable Methods, Techniques, And Practices - Aircraft Alterations are to be used to resolve any issues not specifically addressed by the Installation Manual. Instructions for Continuing Airworthiness (ICA) are provided in the supplied data.

PS Engineering
PAV80 Series IFE System
Installation and Operator's Manual

Operation is subject to the following conditions:

This device may not cause harmful interference.

This device must accept any interference received, including interference that may cause undesired operation.

1.5 SPECIFICATIONS

PAV80 Panel Unit	
FAA-PMA COMPLIANCE	
RELATED DOCUMENTS:	RTCA/DO-214 RTCA/DO-160D RTCA/DO-178B (Level E) RTCA DO-254 (Level E) SAE AS8034
ENVIRONMENTAL Qualifications:	B1BABRSXXXXXXXXZBBBXXMXXXXXXXX
<i>Temperature Range:</i>	
Operating:	-15° C to 55° C
Storage:	-40° C to 85° C
<i>Altitude:</i>	Up to 25,000 feet in a non-pressurized area of the cockpit.
DIMENSIONS:	Height: 2.0 in. (5.1 cm) Width: 6.25 in. (15.9 cm) Depth: 7.7 in. (19.8 cm)
WEIGHT (With Rack & Connectors):	2.8 lb. (1.27 kg)
POWER REQUIREMENTS (Including Internal Lighting):	
<i>Voltage:</i>	11 to 33 VDC
<i>Maximum Current:</i> PAV80 Unit w/1 display	3 Amp (Externally protected by a 5 Amp circuit pull-type breaker.)
<i>Typical operating current:</i> Lighting Current	2A 5 mA
Audio Specifications	
<i>Output Impedance:</i>	150 - 1000 Ω
<i>Audio Output:</i>	38 mW each channel, no clipping <1% THD
<i>Distortion:</i>	<1% THD
<i>Music Freq. Response, 3 dB:</i>	14 Hz –22 kHz
Video Specifications	
Output	NTSC Composite Video Signal S-video available
Radio Tuning	
<i>North America</i>	AM: 530 – 1710 kHz, 10 kHz steps FM: 87.7 – 107.9 MHz, 200 kHz steps
<i>European (--0200)</i>	AM: 531 - 1602kHz, 9kHz steps FM: 87.5 - 107.9MHz, 100kHz steps

PS Engineering
PAV80 Series IFE System
Installation and Operator's Manual

PVT801 Video Terminal Unit	
FAA-TSO COMPLIANCE	
APPLICABLE DOCUMENTS:	SAE AS8034 RTCA/DO-160D RTCA/DO-178B (Level E) RTCA DO-254 (Level E)
ENVIRONMENTAL Qualifications:	B4BABSXXXXXXXXZBBBAUHXXX
<i>Temperature Range:</i>	
Operating:	-0° C to 40°C
Storage:	-20° C to 85°C
<i>Altitude:</i>	Up to 25,000 feet in a non-pressurized area of the cockpit.
DIMENSIONS:	5.98" W x 4.28" H X 1.20" D (152x 108 x 30.5mm) Screen size 5.6" diagonal
WEIGHT:	1.33 lbs (500g)
Input	Composite NTSC, PAL
POWER REQUIREMENTS (Including Internal Lighting):	
<i>Voltage:</i>	Supplied by panel unit
<i>Maximum Current:</i>	
<i>Typical operating current:</i>	
REMOTE	
DIMENSIONS:	2.375" W x 3.80" H X 0.25" D (60 x 93 x 6.4 mm)
Weight	1.0 oz. (28.4 gm)
Power	3 VDC, 1 ea. CR2025 battery
PVA802 Video Distribution Amplifier	
ENVIRONMENTAL Qualifications:	B1CABSXXXXXXXXZBBBAUHXXX
<i>Temperature Range:</i>	
Operating:	-0° C to 40°C
Storage:	-20° C to 85°C
<i>Altitude:</i>	Up to 25,000 feet in a non-pressurized area of the cockpit.
DIMENSIONS:	1.25" H x 4.00" W x 5.50" D (32 x 102 x 140 mm)
WEIGHT	0.6 lbs (0.25 kg)
Input	1 ea Composite NTSC, PAL Control input
Output	4 ea. Composite NTSC, PAL 4 ea. 12 VDC conditioned power @ 1A
POWER REQUIREMENTS	
<i>Voltage:</i>	10-30 VDC 4 A max (5A pull type breaker required)
<i>Maximum Current:</i>	

1.6 EQUIPMENT SUPPLIED

PAV80 Single Display System 1 ea. of the following units:

PS Engineering
PAV80 Series IFE System
Installation and Operator's Manual

Model	Part Number	Description
PAV80	050-800-0100	DVD-IFE System with AM/FM CD MP3
PVT801	050-801-0100	LCD Video Display, 5.5-inch
Remote	051-803-0150	Infrared remote control

PAV80 Installation Kit: 250-800-0001 as shown

Part Number	Description	Quantity
430-730-0020	Tray	1
430-730-0025	Tray/connector shield	1
120-425-4402	44 Pin Connector Key 4/5	1
425-001-0002	Gold Plated Crimp Pins	30
475-440-0007	4-40x7/16" Phil-Pan w/Nylon Patch	2
475-630-0002	6-32 Clip Nut	6
202-800-0101	Pilots Guide	1
510-730-0001	Passive AM/FM Antenna	1

PVT801 Installation Kit: 250-801-0001 as shown

Part Number	Description	Quantity
550-005-2522	5-Pin DIN Jack	1
425-800-2511	Display Cable	1

Optional Equipment

Model	Part Number	Description
PVA802	050-802-0100	Video/Power Distribution Amplifier
Installation Kit	250-802-0100	PVA802 Installation Kit
PVT801	050-801-0100	LCD Video Display, 5.5 -inch
Mounting Bracket	430-800-1362	Portable display Mounting Bracket

PVA802 Installation Kit (250-802-0100)

Part Number	Description	Quantity
425-025-0006	25 pin Sub-d female connector	1
675-025-0001	Connector hood	1
475-002-0002	Thumbscrews	2

1.7 EQUIPMENT REQUIRED BUT NOT SUPPLIED

- a) Circuit Breaker, PULL TYPE: 5 amp as required (1 ea. for PAV80, 1 ea. For PVA802, if used)
- b) Aircraft Audio System (See section 1.8 for approved system list)
- c) Interconnect Wiring
- d) Coax, MIL-C-17/RG179 Quantity, as Required, PS Part No 800-000-0179

1.8 APPROVED AUDIO SYSTEMS

This is a list of audio system that the PAV80 should interface with adequately.

Approved Audio Systems, PAV80

Certified interface is approved only for audio systems that are FAA-TSO approved.

Make	Model	Part Number
PS Engineering	PM1000II	11920,11922
	PM3000	11931, 11932
	PMA6000-Series	6000 (all)
	PMA7000-Series	7000 (all)
	PCD7100	11950, 11951
	PMA4000	11942
	PAC24	050-240-(all)
GARMIN AT	SL10-Series	430-6060-XX
	SL15-Series	430-6065-XX
Bendix/King	KMA28	066-01176-0101
GARMIN International	GMA340	010-00152-XX

1.9 LICENSE REQUIREMENTS

North America- None

International Customers may need to check with appropriate governing bodies before using the system.

Section II - Installation

2.1 GENERAL INFORMATION

2.1.1 SCOPE

These sections provide detailed installation and interconnect instructions for the PAV80 In-Flight Entertainment System with integrated Digital Versatile Disc (DVD) Player and AM/FM radio receiver.

Please read this manual carefully before beginning any installation to prevent damage and post-installation problems. Installation of this equipment requires special tools and knowledge.

NOTE:

An appropriately rated Certified Aircraft Repair Station must install this equipment in accordance with applicable regulations. PS Engineering, Incorporated warranty is not valid unless the equipment is installed by an authorized PS Engineering, Incorporated dealer. Failure to follow any of the installation instructions, or installation by a non-certified individual or agency will void the warranty, and may result in an unairworthy installation.

2.2 *Unpacking and Preliminary Inspection*

Use care when unpacking the equipment. Inspect the units and parts supplied for visible signs of shipping damage. Examine the unit for loose or broken buttons, bent knobs, etc. Verify the correct quantity of components supplied with the list in Section 1.6 (B). If any claim is to be made, save the shipping material and contact the freight carrier. Do NOT return units damaged in shipping to PS Engineering. If the unit or an accessory shows any sign of external shipping damage, contact PS Engineering to arrange for a replacement. Under no circumstances attempt to install a damaged unit in an aircraft. Equipment returned to PS Engineering for any other reason should be shipped in the original PS Engineering packaging, or other UPS approved packaging.

2.3 *Equipment Installation Procedures*

2.3.1 Cooling Requirements

Forced air-cooling of the PAV80 is not required. However, the unit should be kept away from heat producing sources (i.e. defrost or heater ducts, dropping resistors, heat producing avionics) without adequate cooling air provided.

2.3.2 Mounting Requirements

The PAV80 must be rigidly mounted to the instrument panel or other structure of the aircraft structure and within view and reach of the persons wishing access. Installation must comply with FAA Advisory Circular AC 43.13-2A (or later revision). The unit may be mounted in any area where adequate clearance for the unit and associated wiring bundle exist.

The unit may be installed in any orientation.

Avoid installing the PAV80 close to high current devices or systems with high-voltage, pulse type outputs, such as DME or transponders.

2.3.3 Mounting Rack Installation

Remove the unit from the mounting tray by unscrewing the 3/32" hex-head screw that is near the left edge of the unit. Carefully slide the unit free of the tray. Set the unit aside in a safe location until needed. Install the tray using six FHP 6-32 x 1/2" screws. The unit must be supported at front and rear of the mounting tray. See Appendix B.

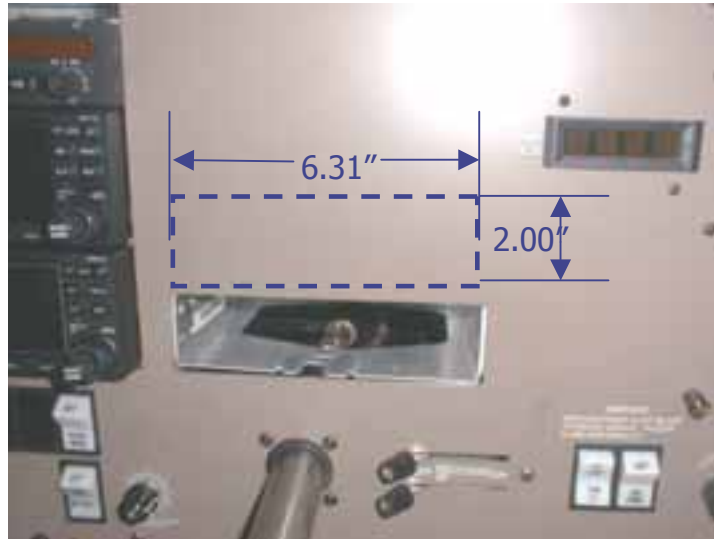

Figure 2-1 Typical Tray Installation Location

The tray mounting can be made in any area that exists for adding additional avionics. Instrument panel mounting is accomplished in accordance with AC 43.13-2A, Chapter 2.

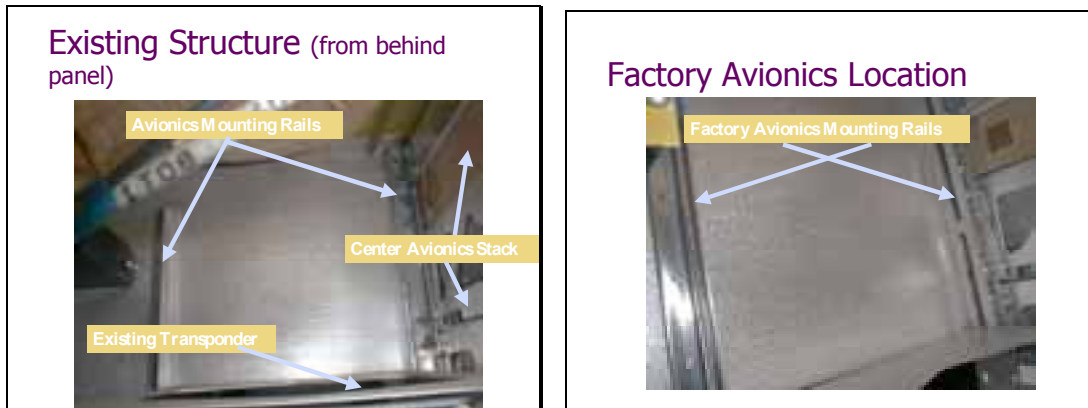

Figure 2-2 Avionics Mounting Rails (Typical)

Panel Opening



Figure 2-3 Completed panel opening (Typical)



Figure 2-4 Completed panel installation

2.3.4 Connector Assembly

The unit connector mates directly with the circuit boards in the PAV80. The connector (part number 120-425-4402 is a Molex crimp-type, and requires the use of a Molex hand crimp tool, EDP P/N 11-01-0203, CR6115B (or equiv.). The connector is mounted to the unit tray with 2 ea. #4-40 screws, from the inside of the tray.

After installing the connector, install the connector shield on the back of the tray with 2 ea #4-40 screws, washers and nuts.

Ensure that proper strain relief and chafing precautions are made during wiring and installation of the tray and shield.

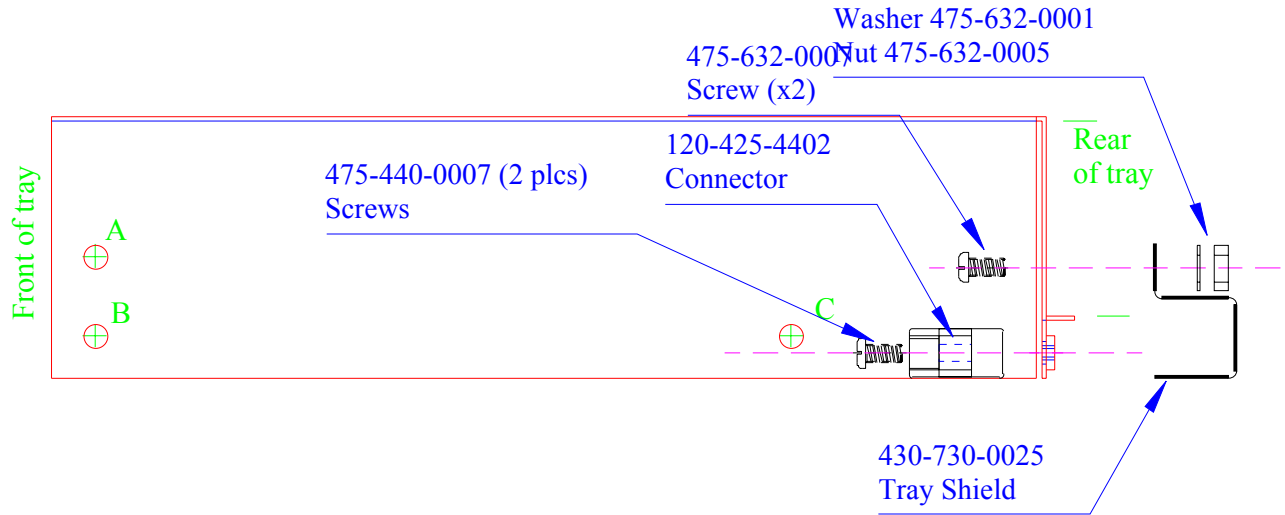

Figure 2-5 -Tray Assembly

2.4 Cable Harness Wiring

Referring to the wiring diagrams contained in the Appendix, assemble a wiring harness as required for the installation. All wires must be MIL-SPEC in accordance with current regulations. Two- and three-conductor shielded wire must be used where indicated, and be MIL-C-27500 or equivalent specification. Proper stripping, shielding, crimping and soldering technique must be used at all times. It is imperative that correct wire be used.

Video Cable wiring shall be 75 Ω coax, MIL-C-17/094, RG179, or equivalent. Because of the small size, we recommend soldering the small conductors from the RG179 coax to provide good contact.

Refer to FAA Advisory Circular 43.13-1B and 2A for more information. Failure to use correct techniques may result in improper operation, electrical noise or unit failure. Damage caused by improper installation will void the PS Engineering warranty. PS Engineering can provide a custom made harness, visit www.ps-engineering.com for more information.

2.4.1 Noise

Due to the variety and the high power of radio equipment often found in today's general aviation aircraft, there is a potential for both radiated and conducted noise interference.

The PAV80 power supply is specifically designed to reduce conducted electrical noise on the aircraft power bus by at least 50dB. Although this is a large amount of attenuation, it may not eliminate all noise, particularly if the amplitude of noise is very high. There must be at least 12 VDC present at the connector pin 21, of the PAV80 for the power supply to work in its designed regulation. Otherwise, it cannot adequately attenuate power line noise. Shielding can reduce or prevent radiated noise (i.e., beacon, electric gyros, switching power supplies, etc.) However, installation combinations can occur where interference is possible. The PAV80 was designed in a RFI hardened chassis and has internal Electromagnetic Interference (EMI) filters on all inputs and outputs.

Ground loop noise occurs when there are two or more ground paths for the same signal (i.e., airframe and ground return wire). Large cyclic loads such as strobes, inverters, etc., can inject noise signals onto the airframe that are detected by the audio system. Follow the wiring diagram very carefully to help ensure a minimum of ground loop potential. Use only Mil Spec shielded wires (MIL-C-275000, or better).

2.4.2 Power

The PAV80-Series units are compatible with both 14 and 28 Volt DC systems. A five (5) Amp PULL-TYPE breaker is required. Power and ground wires must be a twisted #18 AWG pair. Connect airframe power ground to Pin 22 only.

If the Video Distribution Amplifier (PVA802) is used, a second circuit breaker (5 A) must be installed. Power must be connected to the P802, pin 13 only.

NOTE: The PVA80 can power ONE (1) PVT801. Do not connect more than ONE display, and do NOT connect any other type of display to the PAV80 display power pin. DAMAGE WILL RESULT.



Figure 2-6 Circuit breaker location (Typical)

See Appendix B for typical circuit breaker layout.

2.4.3 Backlighting

Connect the 14 V dimmer control to pin 1, the 28 V dimmer to pin A, as required. The display is adjusted for ambient light conditions by the connection to the aircraft dimmer bus. If the radio light dimmer is turned all the way off, the display will be at full intensity.

2.4.4 Antenna

The passive AM/FM antenna, part number 510-730-0001 (included) can be mounted wherever convenient inside the cockpit, as long as it is in a window. Verify that the antenna is not an impediment to crew vision outside the cockpit when installed,

For optimum performance, it should be near the windshield. Clean the mounting surface with appropriate means (glass cleaner, etc), and apply adhesive (supplied with antenna). Route the antenna cable along edge



Figure 2-7 Antenna Installation

to the glareshield, and then connect to the PAV80 connector. Avoid running the antenna cable near high-current carrying wires, such as windshield heat, etc.

The antenna cable center conductor is connected to Pin 2, braid is connected to pin B.

Some installers may desire an external antenna. PS Engineering recommends a Comant CI-222-L, installed in accordance with AC43.13-1A, Chapter 3.

2.4.5 Aux Entertainment Audio and AUX Enable

Besides the disc and AM/FM, the PAV80 has the ability to act as a switching control for an additional entertainment input, both audio and video.

The audio input is Pin 7 (R), Pin H (L) with respect to Pin F (ground).

The video input is Pin 17 (with respect to Pin U)

2.5 Unit Installation

To install the PAV80, gently slide the unit into the mounting rack until the hold-down screw is engaged. While applying gentle pressure to the face of the unit, tighten the 3/32" hex-head in the unit until it is secure. DO NOT OVER TIGHTEN.

Warning: Do not over-tighten the lock down screw while installing the unit in tray.
Internal damage will result.

2.6 PVT801 Display Installation:

The PVT801 is designed to be portable. Install display connectors in a location convenient to the user. The supplied cable from installed connector to the display is six feet (6').

Install the 5-pin display connector (550-005-2522) in a location convenient to the user, perhaps close to the passenger headphone jacks.

A Velcro-strap display case is available from PS Engineering, 1-800-427-2376. In addition, a portable mounting bracket, PS PN 430-800-1362, is available that can hold the PVA801 with double sided tape.



Figure 2-8 Portable mounting bracket with PVA801 attached

2.7 OPTIONAL PVA802 Video Distribution Amplifier Installation

The PVA802 Distribution amplifier is a remote mounted unit that provides 12 VDC power and composite video to multiple displays. This should be mounted as close to the display connectors as practical.

Connect the PVA802 to a 5-amp PULL TYPE circuit breaker. The unit connector is a crimp type, however, we recommend soldering the small conductors from the RG179 coax.

NOTE: This unit can become warm when fully loaded, and should not be mounted where an occupant may have inadvertent contact with it.

The PVA802 should be mounted in accordance with AC43.13-2A, for remote mounted equipment that does not require shock mounting (Chapter 2, Section 24(b)). This also includes any supporting structure that may be fabricated, in accordance with Chapter 2, Sections 25 and 26.



Figure 2-8 PVA802 Dist. Amp Circuit breaker location (Typical)



Figure 2-9 View of typical PVA802 Installation

2.8 Internal Adjustments

None

2.9 Post Installation Checkout

After wiring is complete, verify power is ONLY on pins 21 and Y of the connector, and airframe ground on bottom connector pin 22. Failure to do so will cause serious internal damage and void PS Engineering's warranty.

2.9.1 System Checkout

1. Insert disc, and verify that the player accepts the disk with about $\frac{1}{2}$ of the diameter in the unit. The player should pull the disk smoothly and drop into place.
2. Apply power to the display unit.
3. Verify that the display unit has either the movie opening (if DVD) or the blue background with track information (Music CD or MP3)
4. Verify that all Disc modes operate.
5. Push the "Eject" button and verify that the disc is ejected within about 10 seconds.
6. Verify radio operation on AM and FM
7. Verify that aux audio/video is presented to the output (if connected).
8. Evaluate the audio interface to be certain that the IFE audio is muted during intercom and radio communication.
 - a. If muting override is provided, evaluate the switch location and verify operation.

PS Engineering
PAV80 Series IFE System
Installation and Operator's Manual

- b. Evaluate the audio performance
 - c. Evaluate the audio level to verify that the music is adequate under flight conditions.
 - d. Evaluate the muting system to demonstrate that the music will be adequately muted if desired, by radio and intercom.
 - e. Evaluate the muting override control if equipped.
9. Evaluate failure remediation from crewmember location
- a. Turn unit off
 - b. Locate and pull unit circuit breaker
 - c. With the disc playing, with minimum volume, listen to the following audio sources (as equipped), adjusted to normal listening level:
 - i. Comm 1, comm. 2, comm 3, HF
 - ii. Nav 1, Nav 2
 - iii. ADF (1 and 2)
 - iv. DME (1 and 2)
 - v. Marker
 - vi. Any other audio sources
10. Select FM Mode, and repeat step 6, listening for interference on the aircraft audio sources. Pay particular attention to the frequencies listed in table.

FM	COM
107.3	118.000
107.5	118.200
107.7	118.400
107.9	118.600

FM/COM Cross Reference

11. Select AM Mode, and repeat step 6, listening for interference on the aircraft audio sources.
12. Select COM 1 for transmit. Tune COM 1 to 118.00, and the PAV80 to 107.3 MHz. Transmit a test count and evaluate the unit display and audio output for inconsistencies
13. Repeat step 10 for COM 2, and other transmitters.
 - a. Tune Nav 1 to local station and perform a standard VOT test in accordance with 14 CFR 91.171.
 - b. Note the indicated VOR bearing on both systems.
 - c. Turn the PAV80 on and off, and observe any change in the VOR indication that could be attributed to the PAV80.

2.10 Final Inspection

Verify that the wiring is bundled away from all controls and no part of the installation interferes with aircraft control operation. Move all controls through their full range while examining the installation to see that no mechanical interference exists. Verify that the cables are secured to the aircraft structure in accordance with good practices, with adequate strain relief. Ensure that there are no kinks or sharp bends in the cables and coaxial cables. Verify that the cables are not exposed to any sharp edges or rough surfaces, and that all contact points are protected from abrasion.

Complete logbook entry, FAA Form 337, weight and balance computation and other documentation as required. Sample text for FAA Form 337 and instructions for continuing airworthiness can be found in Appendix F.

Return completed warranty registration application to PS Engineering.

Section III OPERATION

GENERAL INFORMATION

3.1 SCOPE

This section describes the operation of the PAV80 In-Flight Entertainment system.

Operating controls consist of two rotary knobs with push-push switches, and four buttons.

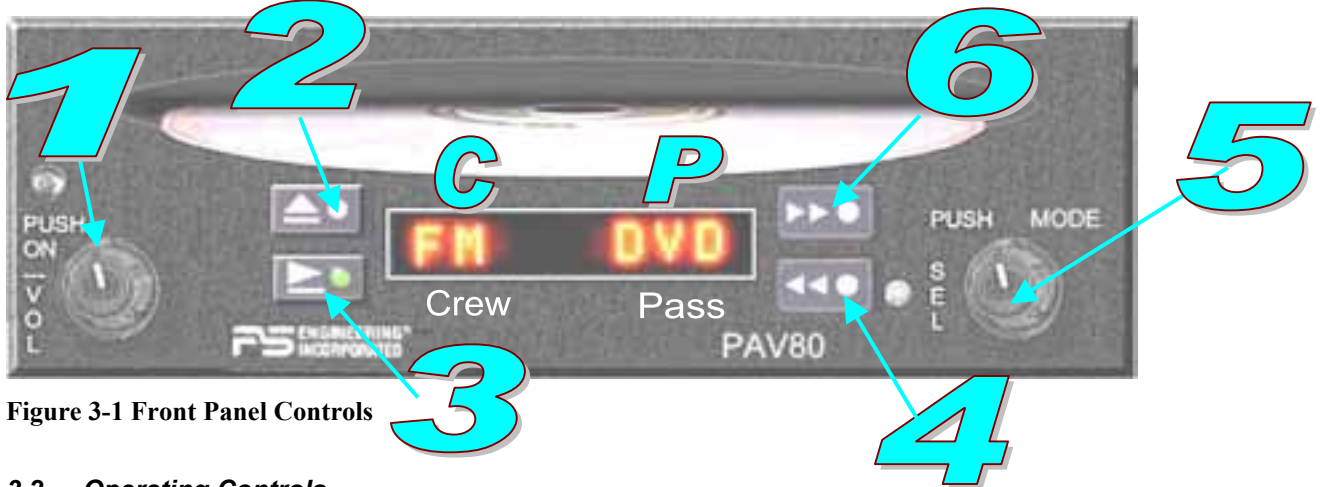

Figure 3-1 Front Panel Controls

3.2 Operating Controls

The single-disk player is designed for simple operation. The Disc player will begin to play automatically when a MUSIC Disc is inserted. The disc will play through in order, and then stop at the end.

If a DVD is inserted, the unit will wait for menu instructions.

3.2.1 Power/Volume Control (1)

The PAV80 system is turned on and off by pushing the volume (left hand) knob. A short press will activate, and deactivate the unit.

The left knob is also the volume control, with 30 steps. The knob controls the volume of the primary output. To modify the volume of the SECONDARY output, press the volume knob for more than 2 seconds. The secondary output indication (right side of window) will blink, and you can now adjust the secondary output volume.

If the knob is not active for more than 5 seconds, the volume control reverts to the primary state.

The four push buttons are used to perform different functions. The function will depend on the mode of the primary audio output, as displayed on the left side of the display (**P**).

3.2.2 ▲ Stop/Eject Button (2)

In disc mode, the Stop/Eject button will stop the disc. Hold for 3 seconds to eject the disc.

In AM/FM mode, this will scan up to the next strong radio station.

3.2.3 ► Play/Pause Button (3)

In disc mode, pressing the play/pause button momentarily will pause the player. Press again to resume play.

In AM/FM mode, this will scan down to the next strong radio station.

3.2.4 The ►► Button (4)

In disc mode, a short press of this button will advance to the next track. A longer press will put the disc into fast forward mode. Press the play/pause button to resume normal play

In AM/FM mode, this button scans up the frequency band.

3.2.5 The Mode Knob (5)

In the Disc mode, the knob will advance (CW) or decrease (CCW) the track.

In AM or FM radio mode, this knob can be used to tune the radio directly.

This knob is also used to select the operational mode. Press the knob once to change the primary mode. The left hand LCD display will blink to indicate that the mode can be changed. Turn the knob to change the mode. Here are the mode selections:

DSK – DVD/MP3/CD mode

FM – FM tuner mode

AM – AM tuner mode

AUX – Auxiliary Audio/Video mode

AXA– Auxiliary Audio Only mode

OFF – Output is disabled

Press the knob again and the right hand side of the display (P) will blink to indicate that the secondary mode can be changed. The knob must be pressed a third time to lock in the mode selection.

3.2.6 The ◀◀ Button (6)

In disc mode, a short press of this button will advance to the previous track. A longer press will put the disc into rewind mode. Press the play/pause button to resume normal play

In AM/FM mode, this button scans down the frequency band.

Table 1-PAV80 Functions

Action	Disc Result	Radio Result
▲ short press	Stop	
▲ long press	Eject (also in AUX)	
▶ short press	Play / Pause	
▶▶ short press	Next track	
▶▶ long press	Fast forward	Increase frequency
◀◀ short press	Previous track	Decrease frequency
◀◀ long press	Rewind	Decrease frequency
DATA knob CW	Select next track	Increase radio frequency
DATA knob CCW	Select previous track	Decrease radio frequency
DATA knob Push	Select operation mode	

Table 2- Button Functions

3.3 Display Operation

The display terminal, PVT801, has the following controls available:

1. Menu: Activates menu function
2. Scroll up: Select menu function
3. Scroll down: Select menu function
4. On/Off and Mode Selector



Figure 3-2 Display Terminal Controls

3.4 Remote Operation

The remote supplied is used to control various functions of the secondary audio output.

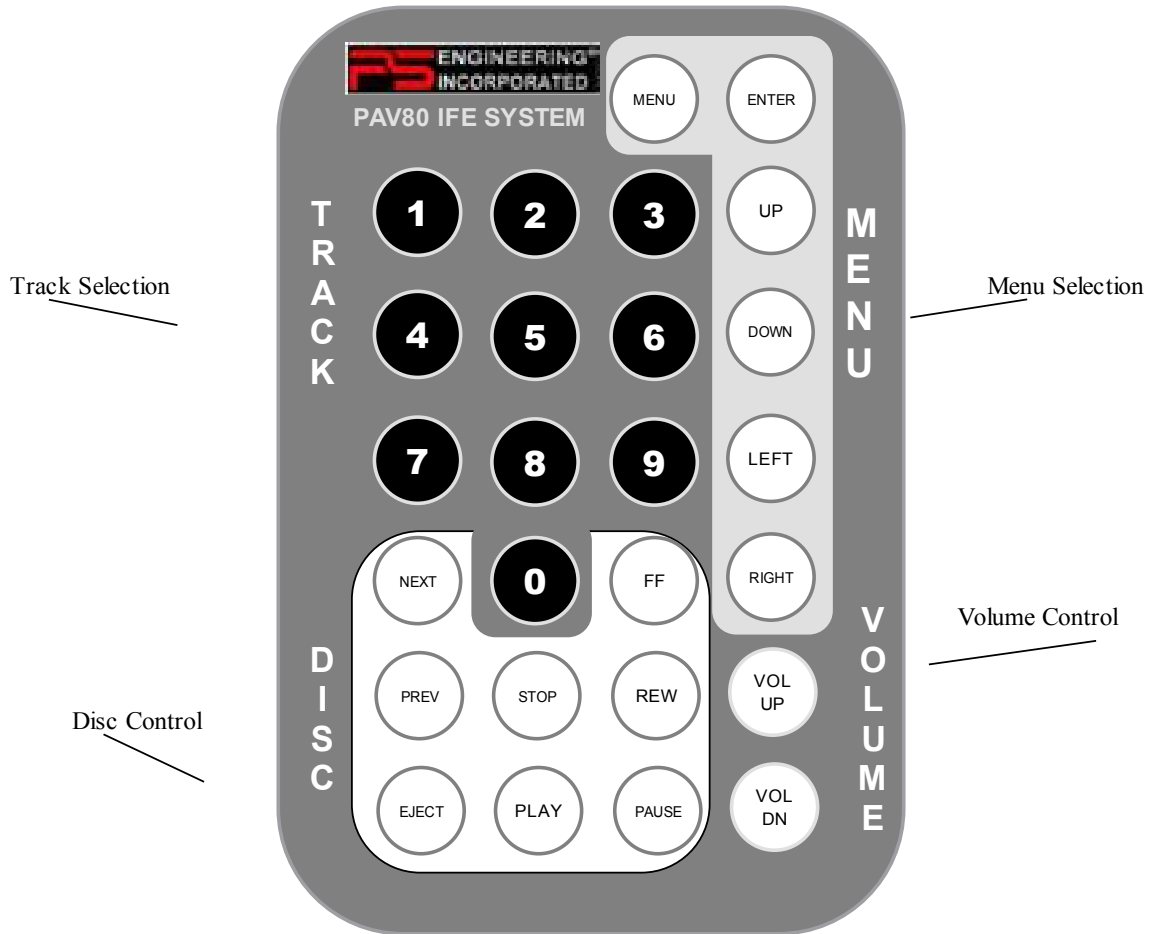
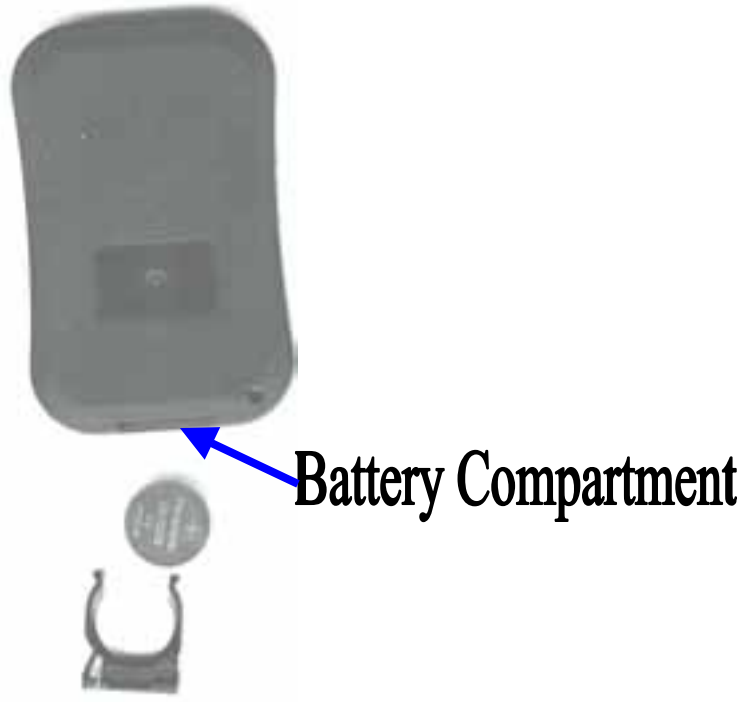

Figure 3-3- Remote Control (not to scale)

The remote uses a 3V CR2025 battery. When the remote becomes weak, replace the battery, through the cover on the bottom.



3.5 Display Dimming

The display can be adjusted for ambient light conditions by the connection to the aircraft dimmer bus. At minimum bus voltage (or no lighting present) the display is set at maximum.

Section IV- Warranty and Service

4.1 Warranty

In order for the factory warranty to be valid, the installations in a certified aircraft must be accomplished by an FAA-certified avionics shop and authorized PS Engineering dealer. If the unit is being installed by a non-certified individual in an experimental aircraft, a factory-made harness must be used for the warranty to be valid.

PS Engineering, Inc. warrants this product to be free from defect in material and workmanship for a period of one (1) year from the date of installation as recorded in aircraft logbook and/or on FAA Form 337. During the **twelve (12) months**, PS Engineering, Inc., at its option, will send a replacement unit at our expense if the unit should be determined to be defective after consultation with a factory technician.

All transportation charges for returning the defective units are the responsibility of the purchaser. All domestic transportation charges for returning the exchange or repaired unit to the purchaser will be borne by PS Engineering, Inc. The risk of loss or damage to the product is borne by the party making the shipment, unless the purchaser requests a specific method of shipment. In this case, the purchaser assumes the risk of loss.

This warranty is not transferable. Any implied warranties expire at the expiration date of this warranty. PS Engineering SHALL NOT BE LIABLE FOR INCIDENTAL OR CONSEQUENTIAL DAMAGES. This warranty does not cover a defect that has resulted from improper handling, storage or preservation, or unreasonable use or maintenance as determined by us. This warranty is void if there is any attempt to disassemble this product without factory authorization. This warranty gives you specific legal rights, and you may also have other rights, which may vary from state to state. Some states do not allow the exclusion of limitation of incidental or consequential damages, so the above limitation or exclusions may not apply to you.

All items repaired or replaced under this warranty are warranted for the remainder of the original warranty period. PS Engineering, Inc. reserves the rights to make modifications or improvements to the product without obligation to perform like modifications or improvements to previously manufactured products.

4.2 Factory Service

The unit is covered by a one-year limited warranty. See warranty information. Call PS Engineering, Inc. at (865) 988-9800 before you return the unit. This will allow the service technician to provide any other suggestions for identifying the problem and recommend possible solutions.

After discussing the problem with the technician and you obtain a Return Authorization Number, ship product to:

PS Engineering, Inc.
Attn: Service Department
9800 Martel Rd
Lenoir City, TN 37772
(865) 988-9800 FAX (865) 988-6619

Email: support@ps-engineering.com

NOTE: PS Engineering will not be responsible for any units shipped in the U. S. Mail.

Units received without either a Return Authorization or a contact telephone number will be refused and returned to the sender.

Appendix A – MP3 Creation

5.1 *Creating MP3s from an Audio CD*

1. Start MusicMatch JukeBox. (www.musicmatch.com) Press the recorder button, which is the small red dot located in the top right corner. This will open the recorder window located at the bottom of the screen.
2. Insert an audio CD into the CD drive. MusicMatch will automatically read the disc and display the contents in the recorder window. Press the REFRESH button to check the Internet database for CD information, such as artist, song title, or album. If this information is available, it will automatically be updated in the file.
3. Select Options->Recorder->Format and select either MP3 or MP3PRO format. You may also set the MP3 file quality under the Options->Recorder->Quality menu.
4. Select the tracks to be copied to MusicMatch by checking the box next to the desired track. Press the record button in the lower left corner when complete
5. MusicMatch will then convert the files from the audio CD to MP3 and display them in the Music Library box located in the middle of the screen
6. To edit the MP3 information, select a file in the Music Library and press the TAG button in the top right corner of the Music Library box. This will display the MP3 tagged information screen. Select the General tab to show the information that can be modified for the PAV80.
7. The PAV80 can display song name, artist, album, and filename. This corresponds to the Track title, Artist, Album, and Track Filename fields shown on the screen. Each of these fields can be modified to the user's preference. Note: The PAV80 is limited to displaying up to 22 characters in each of these fields. Click on the appropriate field to modify the track title, artist, or album. To modify the filename, select the Rename Files button in the lower left corner. Click on the field labeled New File Name and press OK to change the file name. Press the Apply and OK buttons to update the information

Appendix B – Installation Drawings

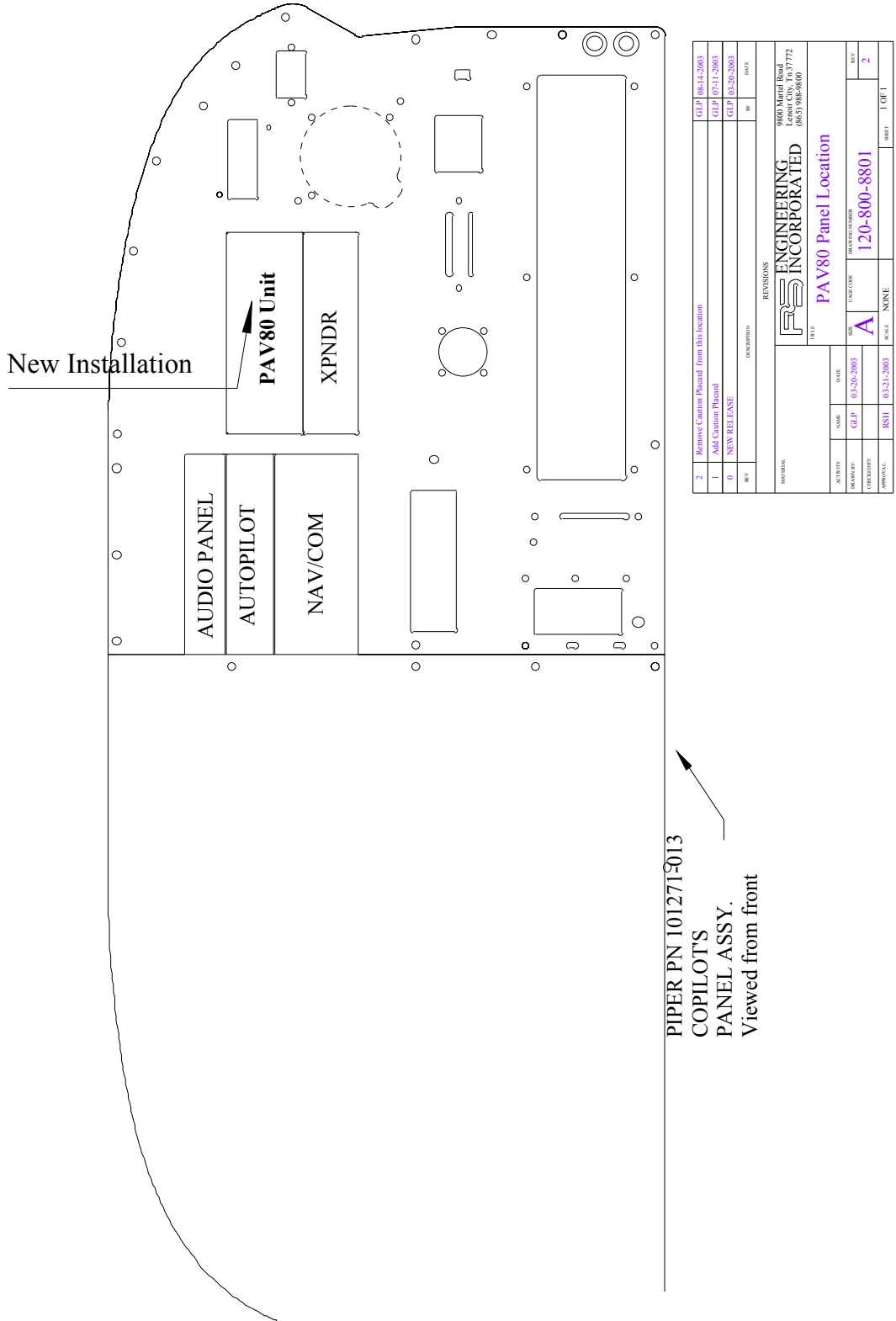
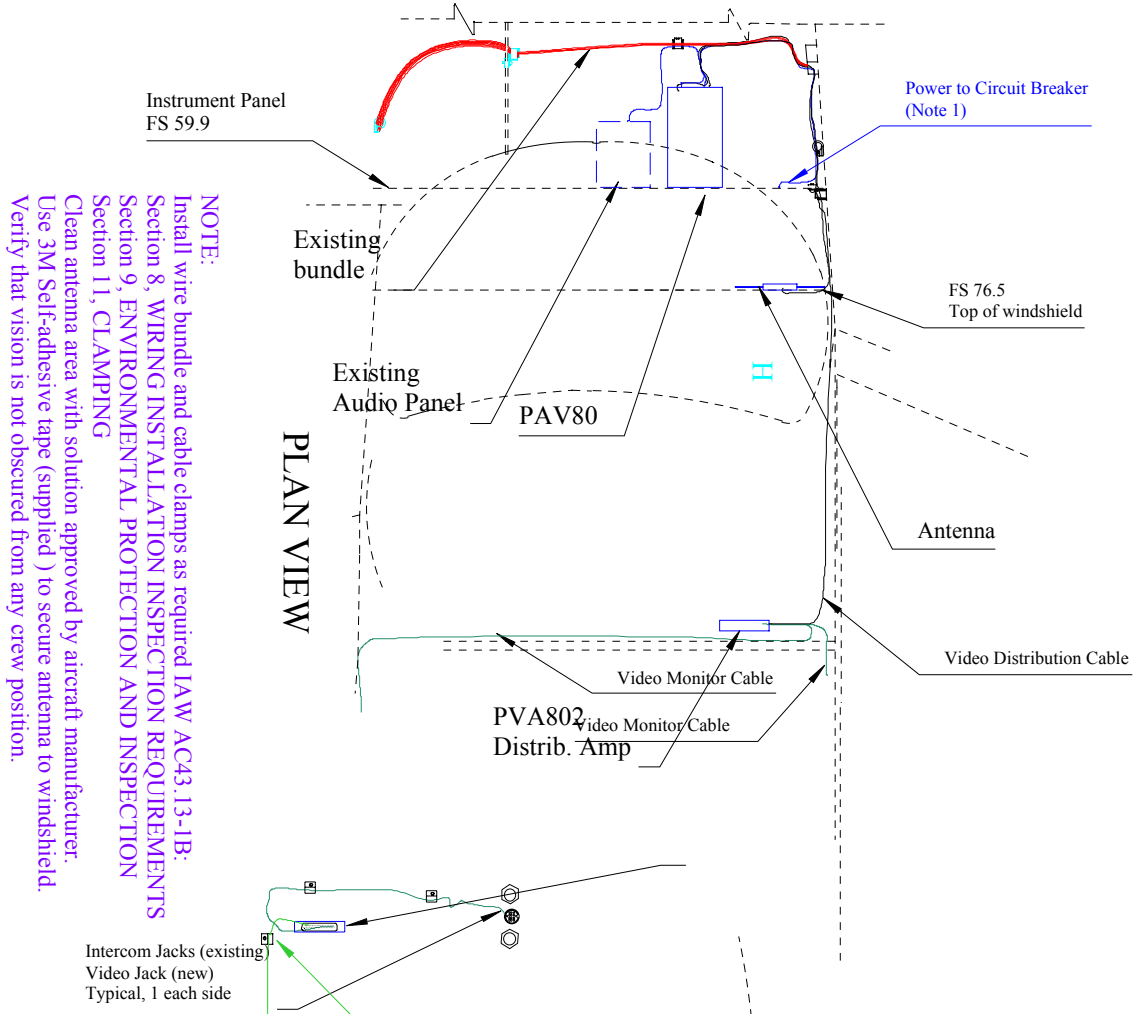

Figure 6-1 Panel Location Drawing (Typical) 120-800-8801

PS Engineering
PAV80
Installation and Operator's Manual



NOTE:
Install wire bundle and cable clamps as required IAW AC43.13-1B:
Section 8, WIRING INSTALLATION INSPECTION REQUIREMENTS
Section 9, ENVIRONMENTAL PROTECTION AND INSPECTION
Section 11, CLAMPING
Clean antenna area with solution approved by aircraft manufacturer.
Use 3M Self-adhesive tape (supplied) to secure antenna to windshield.
Verify that vision is not obscured from any crew position.

PLAN VIEW

ELEV VIEW
From Copilot Side

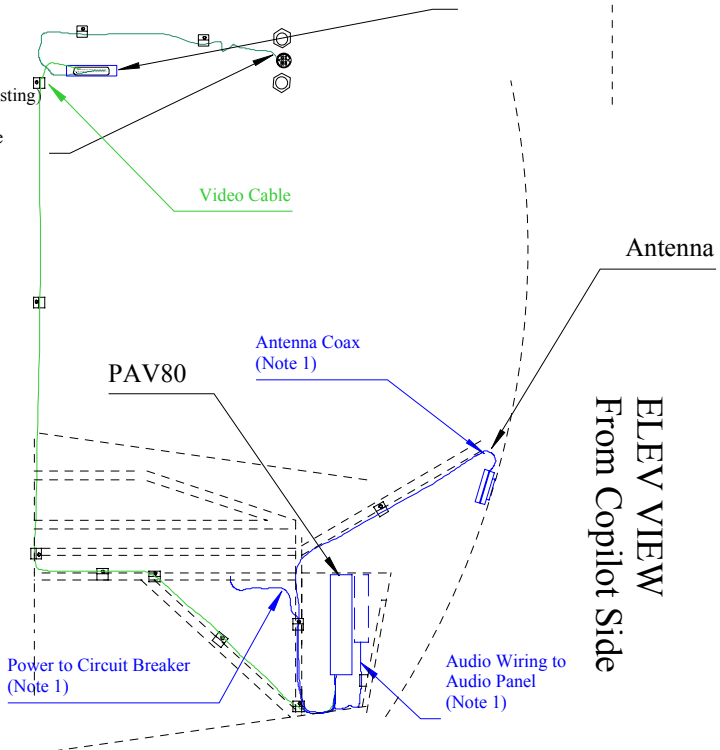

REV	DATE	DESCRIPTION	BY	DATE
1		Issued PVA802	GLP	2-11-03
0		NEW RELEASE	GLP	3-20-2003

ACTIVE	NAME	DATE	SCALE	SCALE CODE	REVISION NUMBER	REV.
	GLP	3-20-2003	A		120-800-2488	1

APPROVAL:	DATE	SCALE	SHEET
MSS	3-21-2003	NONE	1 OF 1

PS ENGINEERING INCORPORATED	9800 Market Road 17772 (865) 988-8600
--------------------------------	---

Figure 6-2 PAV80 Installation Diagram (Typical) 120-800-2488

PS Engineering
PAV80
Installation and Operator's Manual

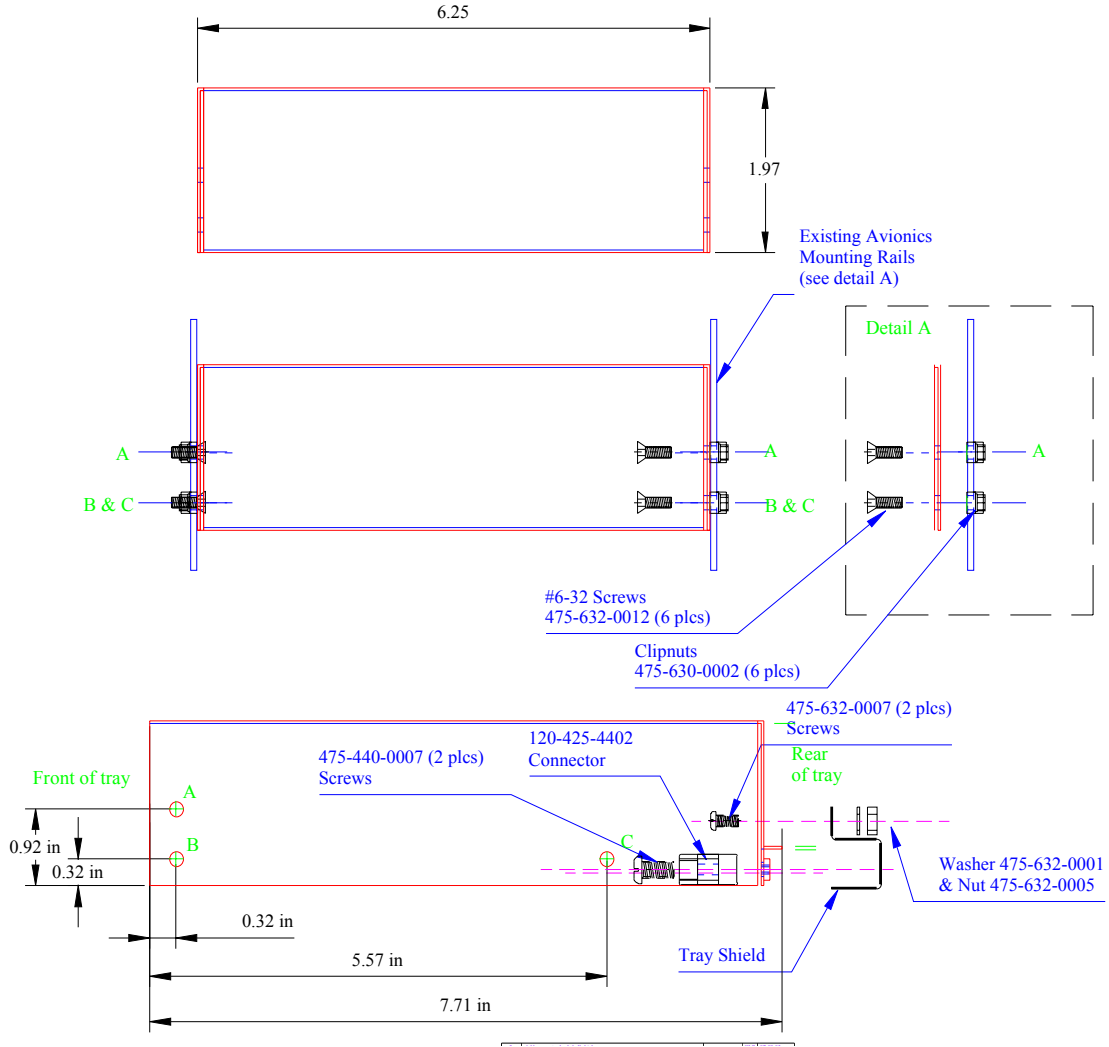
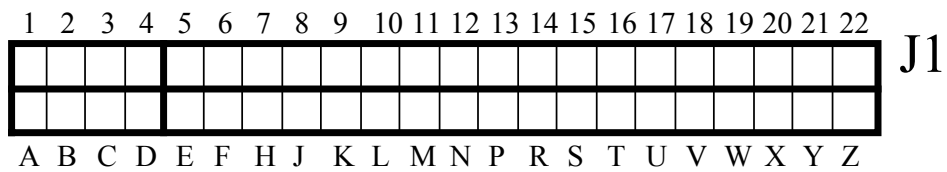

Figure 6-3 Tray Installation Drawing, 002-973-0430

Connector viewed from the rear



Connector viewed from the FRONT of unit tray

Connector Key

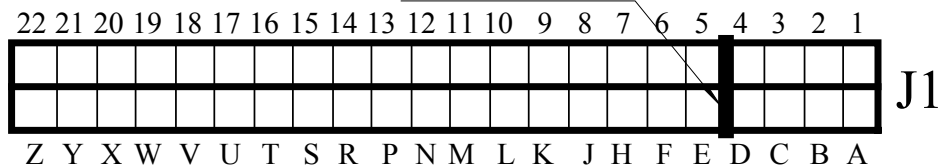

Connector Orientation, PAV80

PVT801 Display Interface

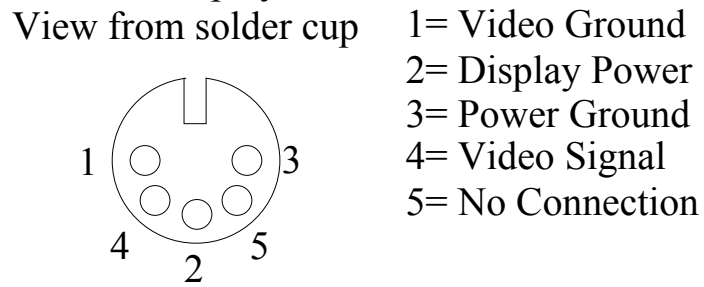

Figure 6-4 Display connector layout

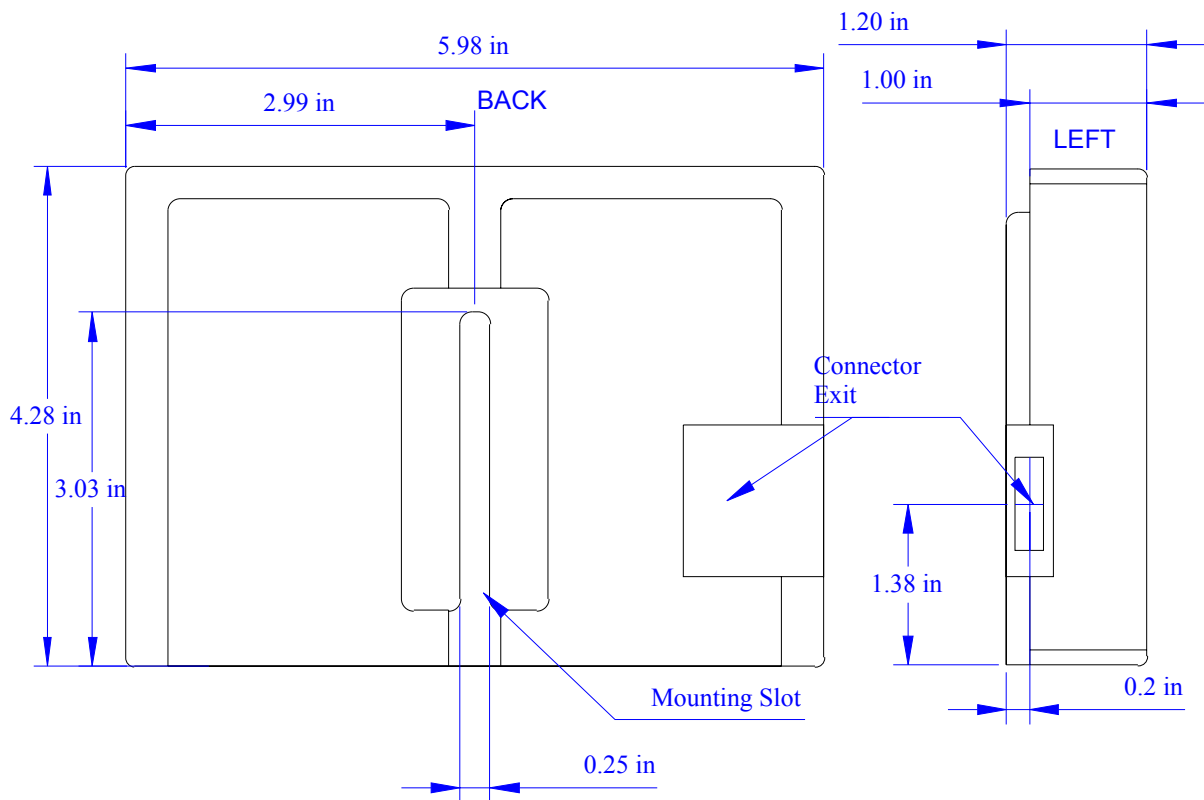

Figure 6-5 - PVT801 Monitor Dimension Details

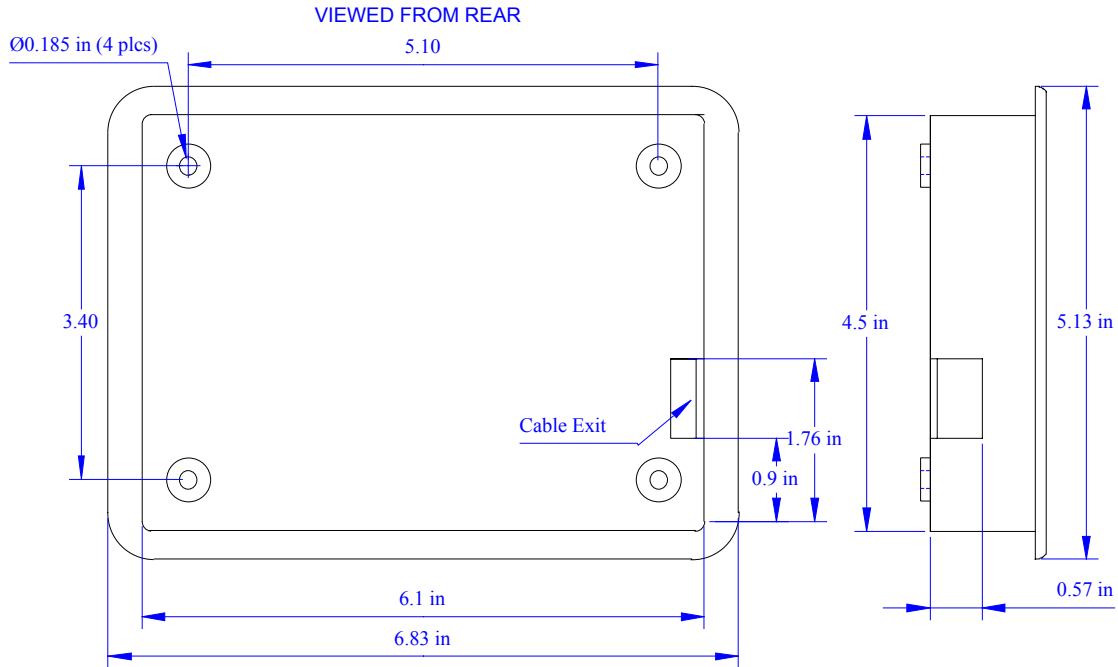

Figure 6-6 PVT801 Mounting Tray Dimensions (if used)

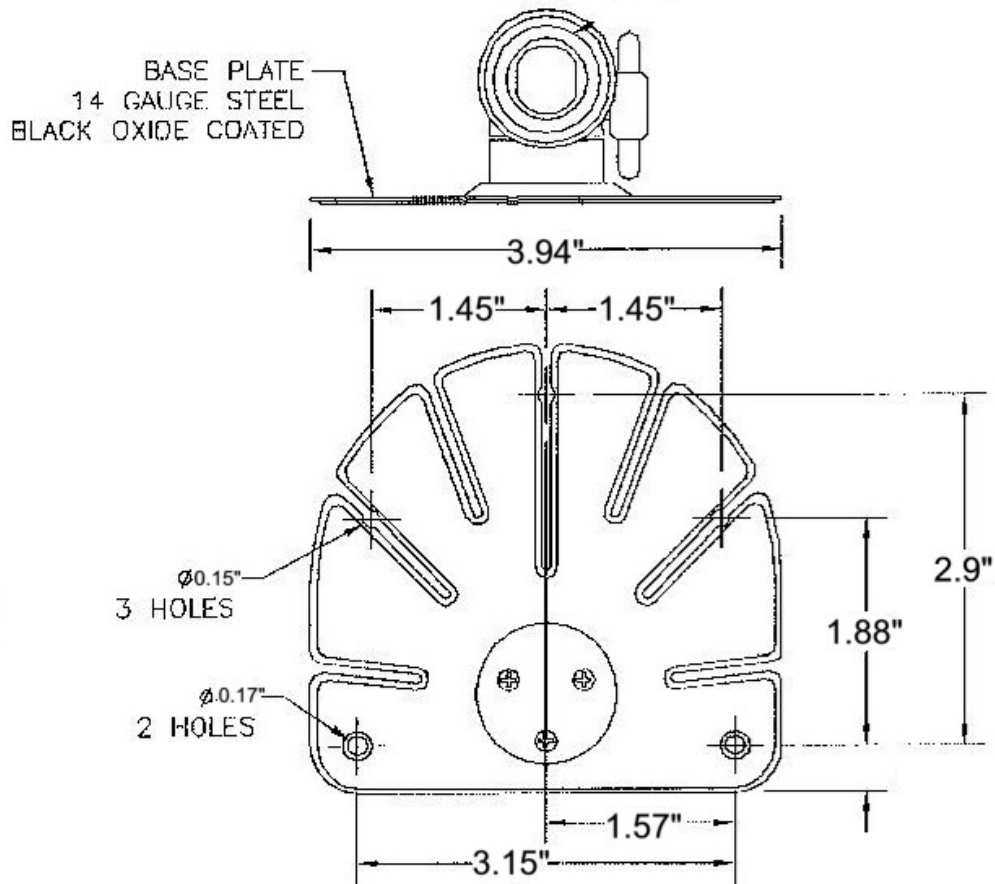

Figure 6-7 Portable bracket drawing (430-800-1362, not to scale)

PS Engineering
PAV80
Installation and Operator's Manual

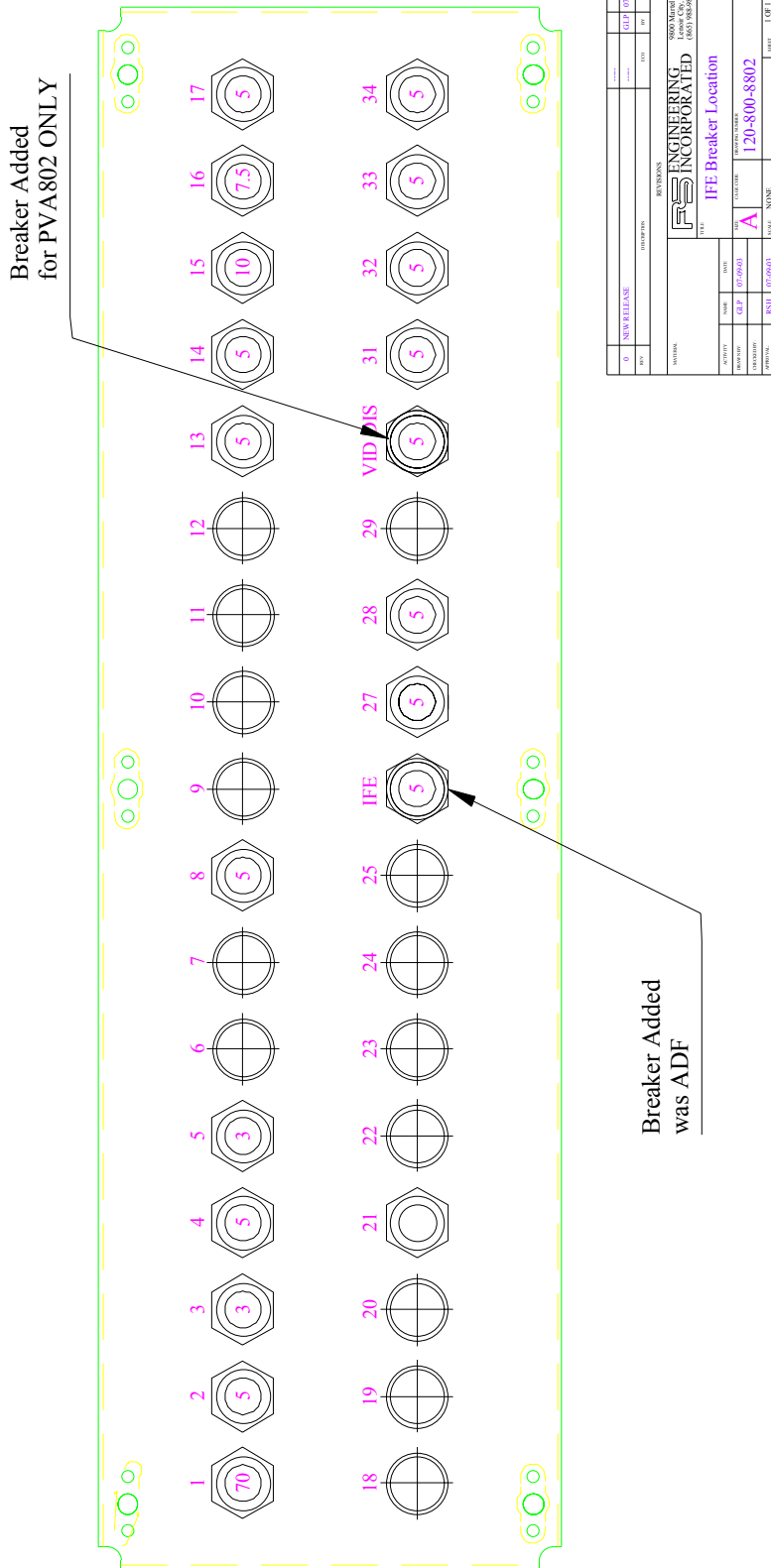

Figure 6-8 Circuit breaker installation drawing 120-800-8802 (typical)

PS Engineering
PAV80
Installation and Operator's Manual

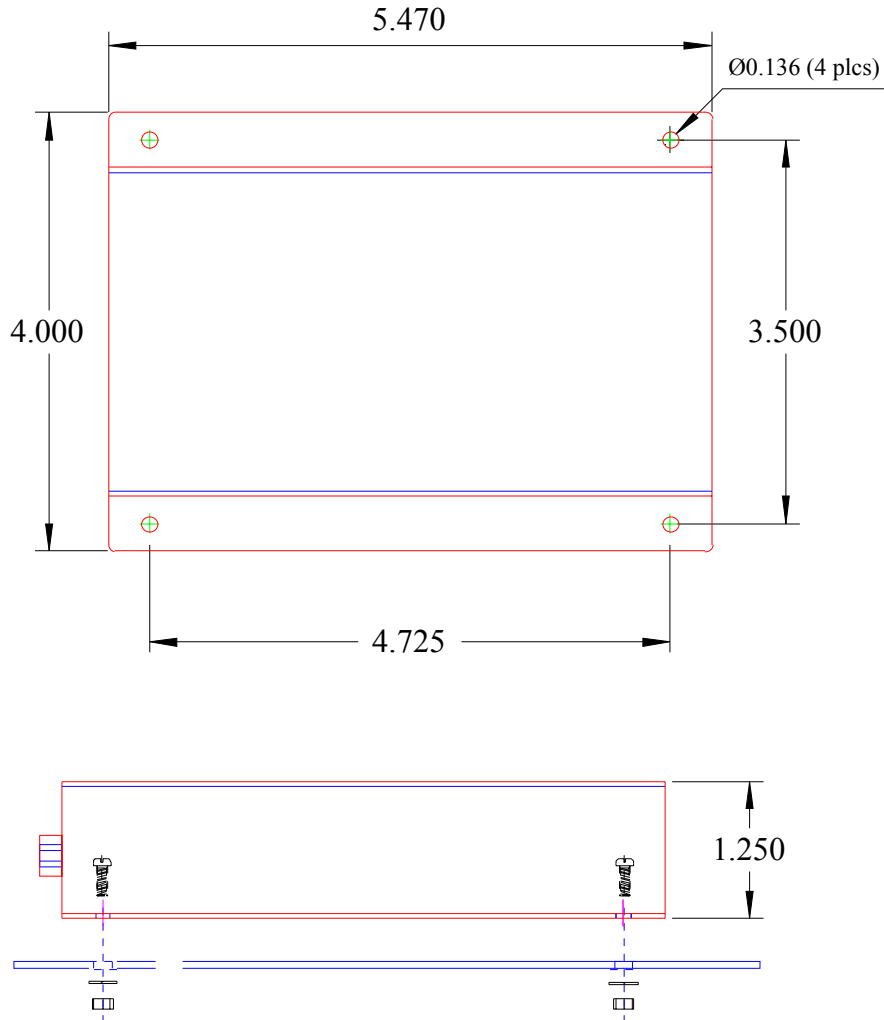

Figure 6-9 PVA802 Video Distribution Amplifier Installation (Dwg. 120-802-0100)

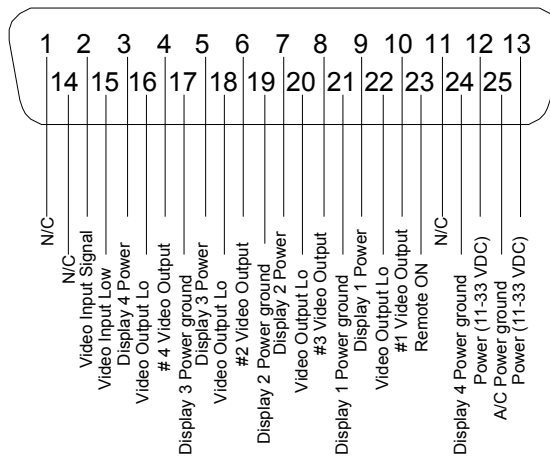
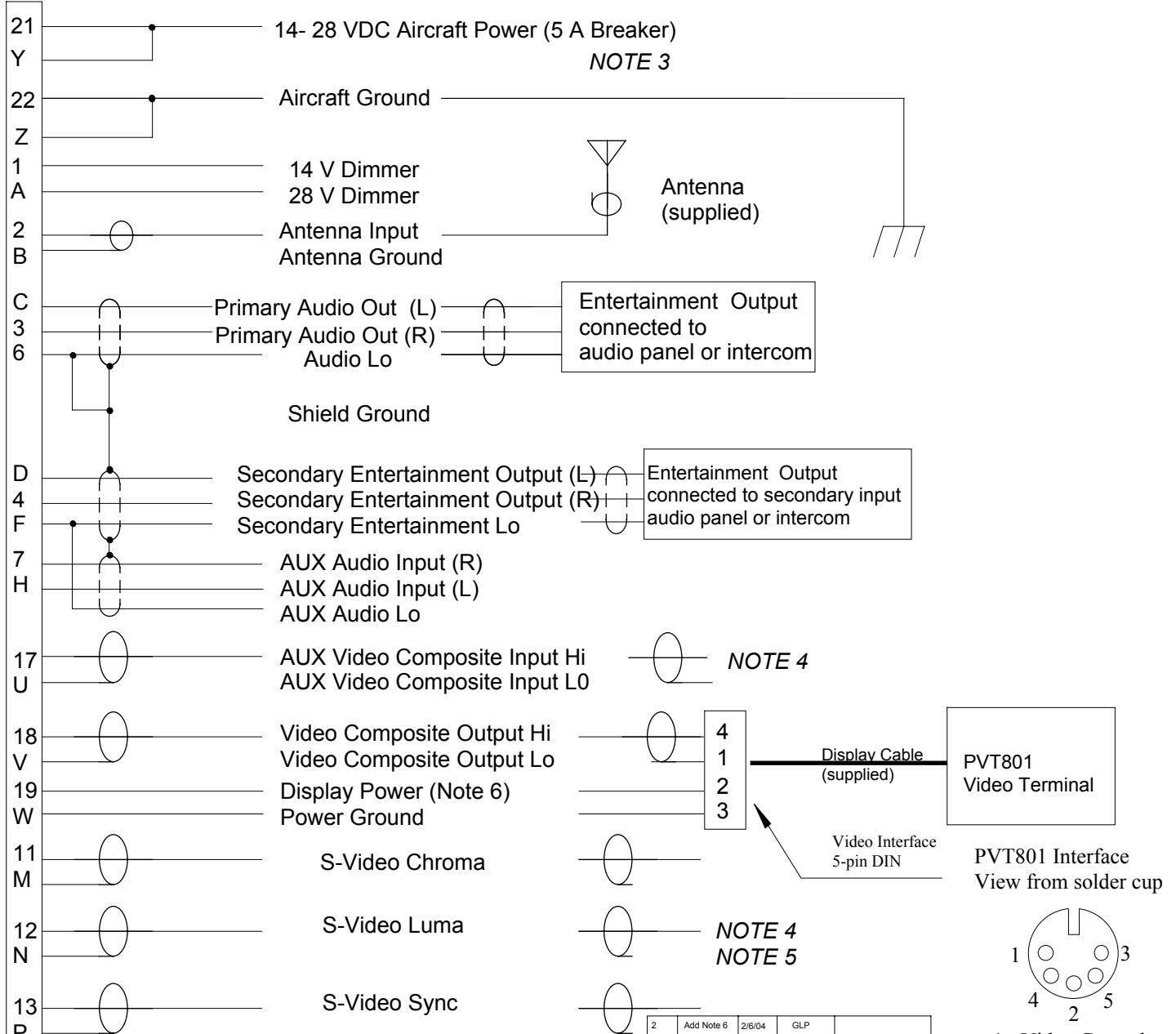

Figure 6-10 PVA802 Connector viewed from cable side

Appendix C Connector Interconnect

7.1 Single Display System

PAV80 Connector



- Notes:
1. All audio wiring must be MIL 22750 or 27500 24 AWG minimum..
 2. Power and Ground #18AWG Mil-Spec Tefzel minimum. Lighting #22 AWG minimum.
 3. Circuit breaker must be PULL TYPE
 4. Video cables must be RG-179/U MIL-C17
 5. S-Video is available for other monitors
 6. Display power for ONE PVT801 display ONLY

2	Add Note 6	2/6/04	GLP	
1	Dis.Conn.	7/15/03	GLP	
REV	Change	DATE	By	APR
DWN	GLP			
DATE	7/09/03			
CKD	RSH			
DATE	7/16/03			
APR				
DATE				
PS ENGINEERING INCORPORATED		3000 MARTEL ROAD, LENOIR CITY, TN 37772		
TITLE: PAV80 Wiring				
SYC	DOCUMENT NUMBER:	REV		
A	128-888-8888	1		
	DATE: 07-15-03	SHEET 1 OF	1	

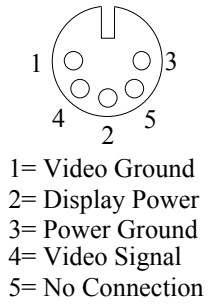

Appendix D- STC information and instructions for continuing airworthiness

8.1 Instructions for FAA Form 337, PAV80s

The STC was developed using an Approved Model List (AML). One method of airworthiness approval is through an FAA Form 337, *Major Repair and Alteration (Airframe, Powerplant, Propeller, or Appliance)* In the case of the PAV80, you may use the following text as a guide.

This unit is installed in accordance with FAA-STC SA02707AT, which specifically references the installation manual.

Installed IFE System, PS Engineering PAV80, part number 050-800-01XX) in (*location*) at station ____ Installed per AC43.13-2, Chapter 2, paragraph 23 (Instrument Panel Mounting). Installed per PS Engineering *Installation Operators Manual* p/n 200-800-(0101), revision (), dated ().

Interface to existing aircraft radios in accordance with installation manual and in compliance with practices listed in AC43.13-2, Chapter 2. All wires are Mil-Spec 22759 or 27500. Connection to aircraft dimmer bus is _____. Power is supplied to the unit through a ___A circuit breaker (type and part number), and total electrical load does not exceed ____% of the electrical system capacity with the PAV80 added.

Aircraft equipment list, weights and balance amended. Compass compensation checked. A copy of the operation instructions, contained in PS Engineering document 200-800-(), revision (), dated (), is placed in the aircraft records. All work accomplished listed on Work Order _____.

8.2 Instructions for Continuing Airworthiness, PAV80s

Sample ICA Checklist for PS Engineering PAV80s:

Section	Item	Information
1	Introduction	Installation of In-Flight Entertainment system.
2	Description	Installation as described in manufacturer's installation manual referenced on FAA Form 337, including interface with other avionics audio as required.
3	Controls	See installation and operator's guide referenced on FAA Form 337.
4	Servicing	None Required
5	Maintenance Instructions	On Condition, no special instructions
6	Troubleshooting	In the event of a unit problem, place the unit into "off," "fail-safe" and/or "emergency" mode. This allows pilot communications using aircraft radios. Follow checkout instructions in the installation manual referenced on the FAA Form 337. For a specific unit fault, contact the manufacturer at (865) 988-9800 for special instructions.
7	Removal and replacement information	<u>Removal:</u> Using a 3/32" Allen-head wrench, carefully unscrew the locking screw located in the center of the unit. While turning the wrench CCW, gently pull on the EDGES of the bezel until the unit is free from the mounting tray. <u>Installation:</u> Engage the locking screw at the back. Turn the locking screw CW, while applying slight pressure to the edges of the bezel. Do not over tighten!
8	Diagrams	Not applicable
9	Special Inspection Requirements	Not Applicable
10	Protective Treatments	Not Applicable
11	Structural Data	Not Applicable
12	Special Tools	None
13	Not Applicable	Not Applicable
14	Recommended Overhaul Periods	None
15	Airworthiness Limitations	Not Applicable
16	Revision	To be determined by installer

PS Engineering
PAV80
Installation and Operator's Manual

8.3 Master Drawing List

The following drawings are contained on the FAA-Approved Master Drawing List, Document Number 002-800-1000:

Title	In this manual	Part Number	Revision	Date
Installation Manual	X	002-800-0101	2	Sept. 2003
Installation Wiring	X	120-800-0000	1	15 July 2003
Tray Installation Drawing	X	120-800-0430	3	09 July 2003
PAV80 Installation Diagram	X	120-800-2488	New	11 July 2003
PAV80 Panel Location	X	120-800-8801	2	14 Aug 2003
PAV80 Breaker Location	X	120-800-8802	New	09 July 2003
Multiple Display Wiring	X	120-800-0100	1	15 July 2003
PVA802 Dist. Amp Installation	X	120-802-0100	New	11 July 2003
Users Guide		202-800-0101	New	July-2003
Flight Manual Supplement				July 11, 2003

* or later revision

8.4 Use of Approved Model List

STC SA02707AT was issued for the installation of the PAV80 entertainment system in one make/model airplane. However, other makes and models are readily adaptable to this approved data since the PAV80 installation is non-required equipment that does not interrelate or affect any aircraft required system. The PAV80 has been qualified under RTCA DO-160D for environmental performance in any of type aircraft when mounted in the avionics section of the airframe.

STC can be used as a basis for approval in those airplanes listed in the Approved Model List (AML, Document Number 002-800-1080) provided the generic installation manual, Document Number 200-800-0101 September 2003 or later approved revision, is followed.

Advisory Circulars AC43.13-1B Acceptable Methods, Techniques, and Practices - Aircraft Inspection and Repair, and 43.13-2A - Acceptable Methods, Techniques, And Practices - Aircraft Alterations are to be used to resolve any issues not specifically addressed by the Installation Manual. Instructions for Continuing Airworthiness (ICA) are provided in the supplied data.

United States of America
Department of Transportation -- Federal Aviation Administration
Supplemental Type Certificate

Number SA02707AT

This certificate issued to PS Engineering Incorporated
9800 Martel Road
Lenoir City, TN 37772

*certifies that the change in the type design for the following product with the limitations and conditions
thereof as specified herein meets the airworthiness requirements of Part 3 of the Civil Air Regulations.*

Original Product - Type Certificate Number: * See attached

Make: FAA Approved Model List (AML)

Model: Document 002-800-1080 for a list of Approved
Airplane Models

Description of Type Design Change: Installation of a PAV80, In-Flight Entertainment Audio-Video System
in accordance with Master Drawing List 002-800-1000, Revision 1, dated August 14, 2003, or later FAA
Approved Revision.

Limitations and Conditions: This approval should not be extended to other aircraft of this model on which
other previously approved modifications are incorporated, unless it is determined by the installer that the
interrelationship between this change and any other previously approved modifications will produce no
adverse effect upon the airworthiness of that airplane. If the holder agrees to permit another person to use
this certificate to alter the product, the holder shall give the other person written evidence of that permission

*This certificate and the supporting data which is the basis for approval shall remain in effect until
surrendered, suspended, revoked or a termination date is otherwise established by the Administrator of the
Federal Aviation Administration.*

Date of application: July 01, 2002

Date received:

Date of issuance: September 3, 2003

Date amended: September 23, 2003



By direction of the Administrator

Eugene L. Bollin
(Signature)

for Melvin D. Taylor, Manager
Atlanta Aircraft Certification Office

(Title)

Appendix E RTCA DO160D/EUROCAE ED-14D Environmental Qualification Form

Part Number: 050-800-(-xxx)

Manufacturer: PS Engineering Incorporated 9800 Martel Road Lenoir City TN 37772

Conditions	Section	Conducted Tests
Temperature and Altitude	4.0	Equipment tested to CAT B1
Low Temperature	4.5.1	-55° C Storage, -20°C Low Operating
High Temperature	4.5.2	+85°C Storage, +50°C High Operating
In-flight Loss of Cooling	4.5.4	Not Applicable, no cooling required
Altitude	4.6.1	25,000' unpressurized
Decompression	4.6.2	Not Applicable
Overpressure	4.6.3	Not Applicable
Temperature variation	5.2	Equipment tested to Category C
Humidity	6.0	Equipment tested to Category A
Shock	7.0	Equipment tested to Operational test only
Operational	7.2	Equipment tested Category B
Crash Safety	7.3	
Vibration	8.0	Equipment tested to Category S
Explosion	9.0	Category X, not tested
Waterproofness	10.0	Category X, not tested
Fluids Susceptibility	11.0	Category X, not tested
Sand and Dust	12.0	Category X, not tested
Fungus	13.0	Category X, not tested
Salt Spray	14.0	Category X, not tested
Magnetic Effect	15.0	Equipment tested to Category Z
Power input	16.0	Equipment tested to Category B
Voltage Spike	17.0	Equipment tested to Category B
Audio Frequency Susceptibility	18.0	Equipment tested to Category B
Induced Frequency Susceptibility	19.0	Category X, not tested
Radio Frequency Susceptibility	20.0	Category X, not tested
Radio Frequency Emission	21.0	Equipment tested to Category H
Lightning Induced Transient Susceptibility	22.0	Category X not tested
Lightning Direct Effects	23.0	Category X not tested
Icing	24.0	Category X, not tested
Electrostatic Discharge	25.0	Category X, not tested
Other Tests		Passed FM Emissions testing in accordance with CFR 47, Part 15.109.