



ESN E5 6.5" Wide TFT Touch-Panel Display CD / DVD Multi-Source Receiver with DVD Navigation

MODEL **AVN5435**

INSTALLATION MANUAL

Be sure to read this installation manual thoroughly before carrying out installation and making connections. If installation methods or non-standard parts that are not specified in this installation manual are used, accidents or injury may result.

Professional installation is recommended, contact the place of purchase to schedule an appointment. After reading the owner's manual and the installation manual thoroughly, keep them in a safe place for later reference.

To dealers:

Give this installation manual to the customer after installation and connections have been completed.

Contents

Before installation

Components	2
For your safety in using the AVN5435	3
Installation Diagram	5

Connections

Names and functions of terminals	6
Connecting the vehicle speed pulse signal, parking brake signal cable and reverse cable	10
System connection example	13

Installation

Installing the GPS antenna	14
Installing the main unit	17

Components

Check that all of the following components are present

Main unit components

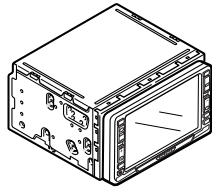

① Main unit x 1

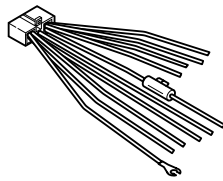

② Interconnecting cable
(Power and front speaker connector)
(10P) x 1

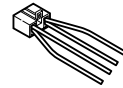

③ Interconnecting cable
(Rear speaker connector)
(6P) x 1

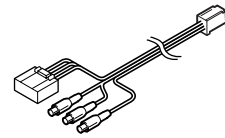

④ Interconnecting cable
(video input and steering
remote control connector)
(6P) x 1



⑤ Antenna
extension cable x 1



⑥ Hex-head bolt
(Red:M5x8) x 8



⑦ Flathead screw
(Red:M5x8) x 8



⑧ Splicing connector
x 3

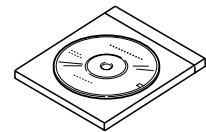

⑨ MAP DVD-ROM x 1

GPS antenna components

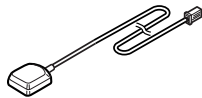

⑩ GPS antenna
x 1



⑪ Waterproof cushion
x 1



⑫ Ground plate
x 1



⑬ Body protective sheet
x 1

Wiring components



⑭ Clamp
(for GPS antenna) x 3

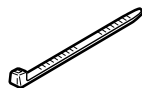

⑮ Cable tie
(for GPS antenna) x 4

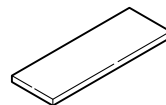

⑯ Harness fixing tape
x 2



Tip

When installing the main unit, some vehicle models may require the use of items that need to be obtained separately such as a power supply adaptor cable, radio antenna adaptor cable or mounting bracket.

For your safety in using the AVN5435

Warnings and caution signs, illustrated bellow, are posted throughout this manual as well as on the AVN5435. They show safe and correct ways to handle the product so as to prevent personal injury to you and others and avoid damage to property.

Before reading through the manual, take time to read through and learn the important information listed in this section.



Warning

This sign indicates a situation in which incorrect handling through disregard of a sign might result in death or serious personal injury.



Caution

This sign indicates a situation in which incorrect handling through disregard of a sign might result in personal injury or may result solely in damage to property.



Tip

This section contains information that can help to prevent problems and damage to the unit, and also contain other useful information.

Warning

- Do not install this product in locations where it may obstruct the driver's view, or where it may endanger passengers in the vehicle. Otherwise, an accident or injury may result.
- Do not install this product in locations where it may interfere with the operation of the steering wheel, shift lever, brake pedal, etc. Otherwise, an accident or injury may result.
- To prevent damage to the vehicle, confirm the locations of hoses, electrical wiring, and the fuel tank prior to drilling holes to install this product. Also, take care so that the product does not interfere, nor come in contact with them. Otherwise, a fire may result.
- When installing this product, never use the existing nuts or bolts that secure parts of the fuel tank, or the steering or braking systems. Otherwise, improper steering or braking or a fire may result.
- To prevent a short circuit from occurring, disconnect the battery's negative terminal before installing this product. Otherwise, an electric shock or injury may result.
- When using an existing nut and/or bolt from the vehicle to ground this product, do not use any that secure parts of the steering or braking systems. Otherwise, an accident may result.
- Bundle cables and harnesses with electrical tape or wire ties to prevent them from interfering with moving parts. If they should entangle with the steering wheel, shift lever or brake pedal, an accident may result.
- Never supply power to another electrical appliance by splicing or tapping into this product's power lead (wire). Otherwise, the current capacity of the wire will be exceeded, resulting in a fire or electric shock.
- Never attempt to disassemble or modify the product. Otherwise, an accident, fire or electric shock may result.
- When replacing fuses, be sure to use fuses of the specified capacity (amperage). Otherwise, damage to the unit, fire or an electric shock may result.
- When installing the product into a vehicle with a passenger side air bag, do not secure it to the air bag's cover or in places where it may impede air bag deployment. Otherwise, proper air bag operation may not be ensured in the event of an accident, causing injury or death.
- When making holes using drill or similar tool, be sure to wear protective eyewear. Otherwise, an injury such as loss of eyesight may result.
- Exposed wires must be insulated with electrical tape. Otherwise, a short circuit, fire, or electric shock may result.
- Do not modify this system for use other than that specified herein. Also, do not deviate from the installation procedures described herein; Eclipse will not be held liable for damages including, but not limited to serious injury, death or property damage resulting from installations that enable unintended operation.

Warning

- This unit is intended for operation in DC 12volt, negative-grounded vehicles only. Never use it in 24-volt vehicles such as heavy trucks or diesel cars with cold-region specifications.
- Do not place the vinyl storage bag over a person. It may cause a serious accident or death by suffocation.
- Do not disassemble or rebuild this product. Doing so may cause an accident, fire or electrical shock.
- When it is necessary to replace the fuse, always use a fuse of the correct rating (number of amperes). Use of fuses with higher amperage ratings may cause a fire.
- Do not operate the product in a malfunctioning condition, for instance, when the audio does not play. Doing so may result in an accident, fire or electrical shock.
- If an abnormal situation occurs, such as foreign matter entering or liquid splashing on the product, or smoke or a strange odor emitting from the unit, shut off the product immediately and consult the dealer from whom you purchased it. Continued operation may cause an accident, fire or electrical shock.

Caution

- For best results, this product should be installed by a professional installer. Contact the dealer whom you purchased the product for an appointment.
- When installing this product, be sure to use the supplied mounting hardware. If parts other than those supplied are used, the unit may be damaged internally, or may not be held in place securely and become dislodged.
- Avoid installing this product in places where it may get wet, such as near windows, or in places that are moist or dusty. Presence of liquid, moisture or dust inside this product can cause short circuiting resulting in smoke or fire.
- If this product is not connected properly, a short circuit, fire or accident may occur.
- When routing cables, use care so that they do not contact sharp metal parts such as brackets or screw tips. Otherwise, a short circuit, electric shock, fire or accident may result.
- Play the audio at a moderate volume level that permits you to hear sounds from outside the car. Driving without being able to hear outside sounds may result in an accident.
- This product must be operated only as on-board equipment, or it may cause electrical shock or injury.
- Do not play distorted sounds for long periods of time; the speakers may overheat and cause a fire.

Installation Diagram

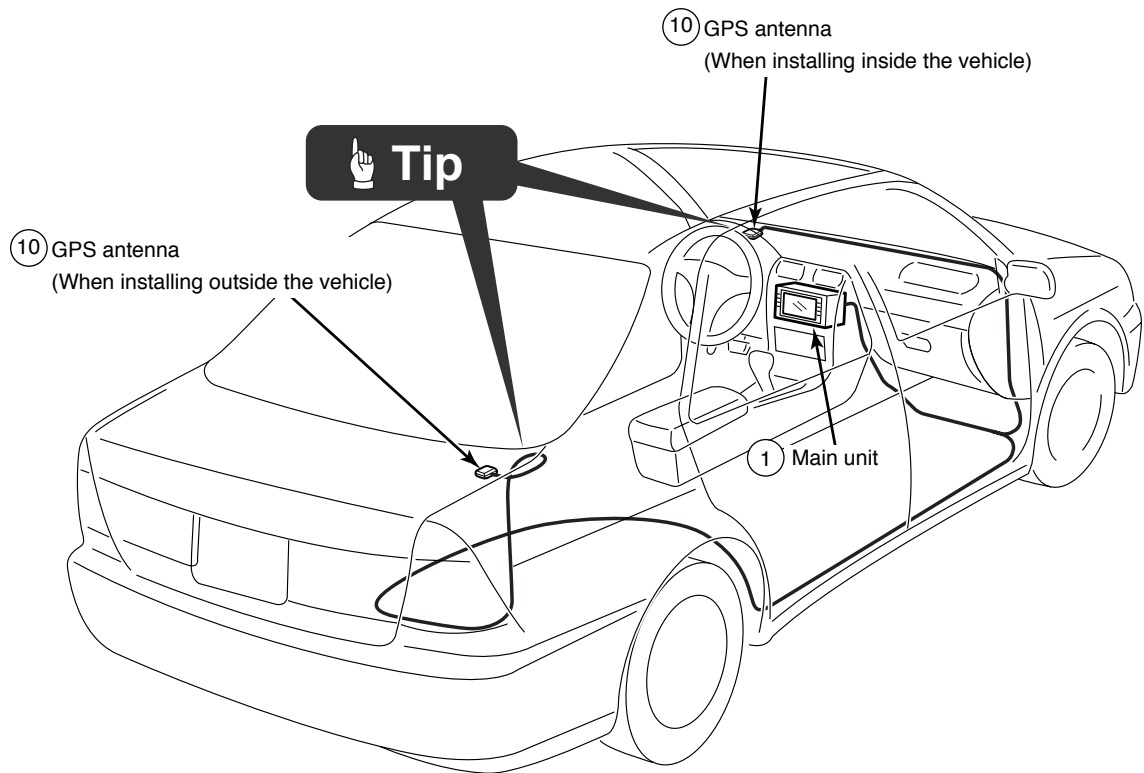

Tip

- If installing the GPS antenna inside the vehicle, the location and the slope of the vehicle's windshield will determine the accuracy of the GPS antenna to receive the GPS signal. If this occurs you may want to install the antenna outside of the vehicle.
- The materials used in front and rear vehicle windows can cause GPS reception sensitivity to drop significantly. If this happens, install the GPS antenna on the outside of the vehicle.

Names and functions of terminals

⚠ Warning

- Never cut the insulation on the power cable or use it to power any other equipment. If the rated current capacity of the power cable is exceeded, fire and electric shocks may result.
- The cables should be secured with tape or similar so that they will not cause an obstruction while driving. If they get wound around components such as the steering wheel, shifting lever or brake pedal, accidents may result.

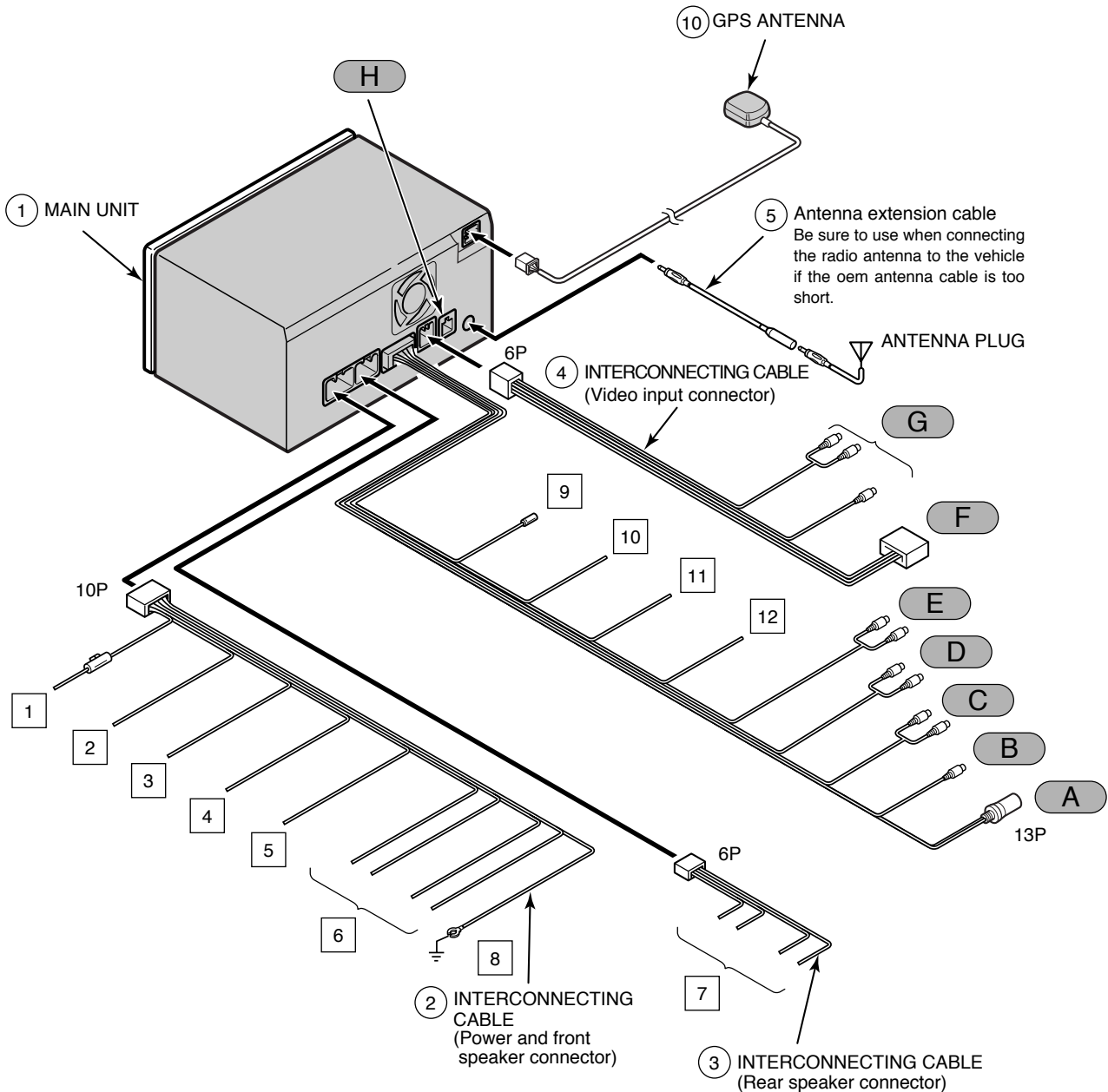

👉 Tip

- Refer to page 7 for details on the wire colors and connection points for interconnecting cables ②, and ③ and ④.
- Refer to page 8 for details on connection points A, B, C, D, E, and H for the main unit cables and terminals.

◆Wire colors and connection points for connection cables ② and ③ and ④



Never connect the power supply to the speaker leads (No.6 and No.7), otherwise it will cause damage to the main unit.

1 B+ (Yellow)

Connect where power is constantly available, regardless of the ignition key's position.

2 ACC (Red)

Connect where the power comes on when the ignition is in the ACC position.

3 Illumination power supply (Orange/White)

Connect to where power comes on when the vehicle light switch is turned on.

4 Antenna power supply (Blue)

Connect to the automatic-antenna control terminal of the vehicle.

5 Control power supply (Blue/White)

Connect the control terminal for the external amplifier, etc.

6 Front speaker output leads

Connect to the front speakers.

White: Left +

White/black: Left -

Gray: Right +

Gray/Black: Right -

7 Rear speaker output leads

Connect to the rear speakers.

Green: Left +

Green/black: Left -

Purple: Right +

Purple/Black: Right -

8 Ground (Black)

Connect where good body grounding is available.

F

Genuine steering remote control terminal

Connect to the vehicle steering remote control.

Compatible vehicle models for installation : Vehicles with voltage detection-type steering remote control.

Ask your dealer for details.

G

VCR external input terminal (6P)

Connect to the output cable of external video equipment such as a VCR.

◆Main unit connections

9 ACC ON/OFF power supply terminal (blue/white)

If you use this terminal to connect equipment such as an external amplifier, you can still hear the audio guidance from the navigation system even when audio is turned off. Connect it to the control terminal for the external amplifier or other equipment.

A popping noise may be heard when the engine is being started or the ignition switch is at the ON position, but this is normal and is not the sign of a malfunction.

10 Vehicle speed pulse signal terminal (Purple/White)

Connect to the vehicle speed pulse signal terminal.

11 Parking brake signal (Red/White)

Connect to the parking brake signal terminal.

12 Reverse signal Wire (Green)

Connect the reverse signal output of the vehicle to this terminal.

A E-LAN terminal (13P)

Connect to the E-LAN terminal of the CD changer, etc.

B VIDEO OUT terminal (Yellow)

Connect to an external monitor with video input.

C Front line-out terminal

Connect to the RCA connector of an external amplifier.

D Rear line-out terminal

Connect to the RCA connector of an external amplifier.

E Line-out terminal (Non fader)

This is used for non fader output. It can be used as a sub-woofer terminal if a separate amplifier with a low bass filter is connected.

H Back-eye camera external input terminal (4P)

Used with the Eclipse back-eye camera (sold separately).

– Vehicle connections –



Tip

- You will need to purchase the necessary component adapter cable for the vehicle so that the power supplies can be utilized. (Contact the dealer for further details.)
- Be sure to wrap the connection cables with plastic tape to insulate them.

– Example of using vehicle adapter cables –

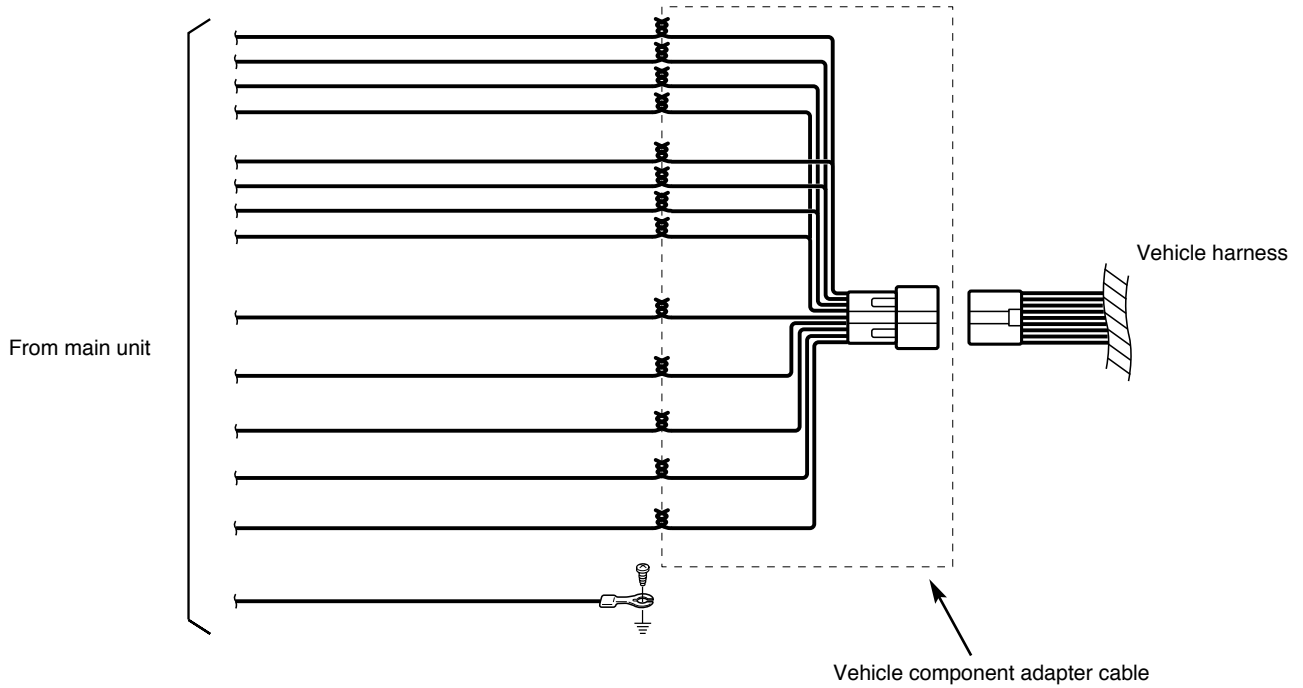

Connecting the vehicle speed pulse signal, parking brake cable and reverse cable

Notes on installation

Warning

- Check the vehicle speed pulse signal, parking brake signal and reverse signal carefully before making the connections. If the cables are incorrectly connected, accidents or problems with correct operation may result.
- The label on the vehicle speed pulse signal cable contains a protection circuit, so do not cut the cable or remove the protective circuit, otherwise problems with operation may result.
- Bind the cables together with tape so that they do not cause an obstruction while driving. If they become wound around parts such as the steering wheel, shifting lever or brake pedal, accidents may result.

Tip

The locations where the vehicle speed pulse signal cable, parking brake signal cable and reverse cable come out vary depending on the vehicle model and grade. Ask the place of car dealer or your nearest Eclipse dealer for details.

– An example for connecting the vehicle speed pulse signal cable –

Tip

Always be sure to connect the vehicle speed pulse, otherwise the measurement precision will be greatly reduced.

- 1 Use a splicing connector to connect the vehicle speed pulse signal cable (purple/white) coming from the main unit to the vehicle speed pulse signal cable of the vehicle.
- 2 Route the vehicle speed pulse signal cable to the main unit.

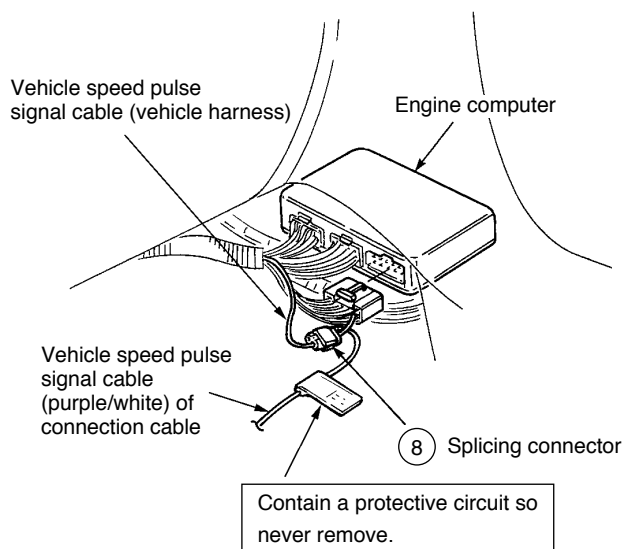

– An example for connecting the parking brake signal –

- 1 Use a splicing connector to connect the parking brake signal cable (red/white) coming from the main unit to the parking brake signal cable of the vehicle.
- 2 Route the parking brake signal cable to the main unit.

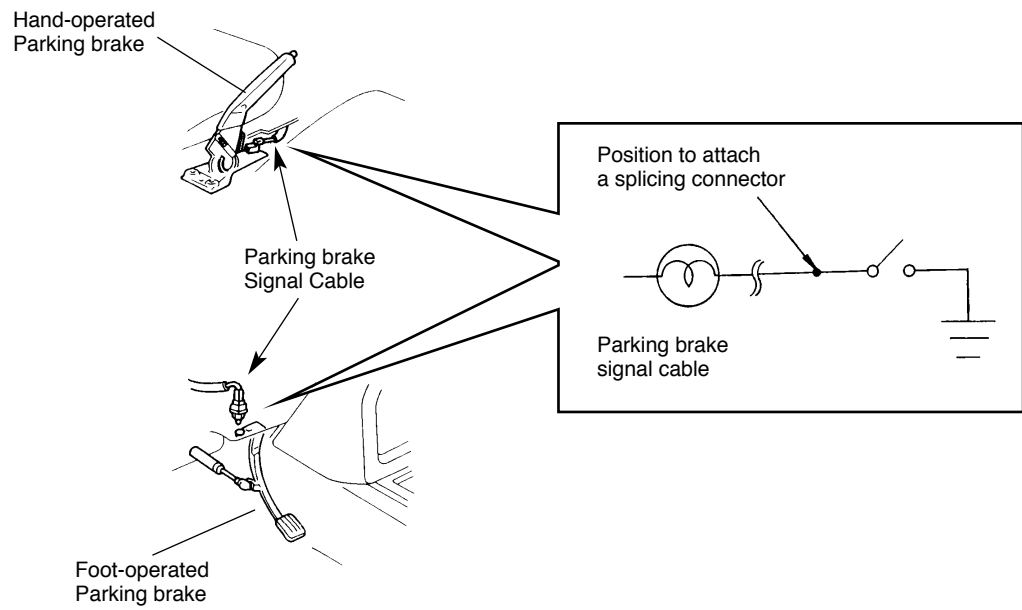

– An example for connecting the reverse signal cable –

 **Tip**

- Be sure to connect the reverse signal cable. If it is not connected, the vehicle position may be incorrect when the vehicle is reversed.
- Use a circuit tester to confirm that a sensing voltage of 6 V or higher is generated when the vehicle is reversed.

- 1 Use a splicing connector to connect the reverse signal cable (green) coming from the main unit to the reverse signal cable of the vehicle.
- 2 Route the reverse signal cable to the main unit .

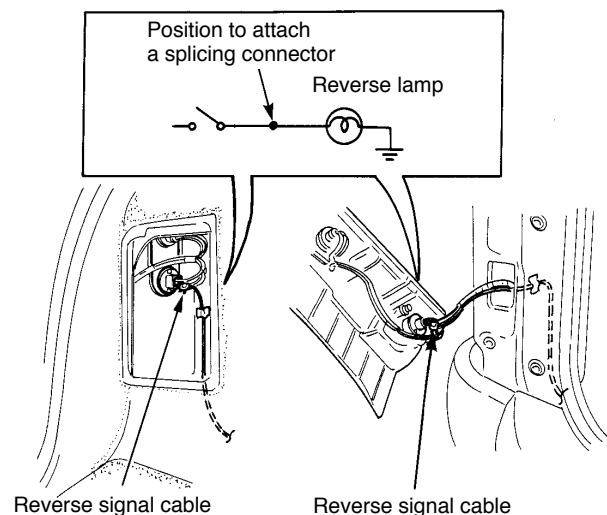

- Using the splicing connector -

1 Insert the connection cable [vehicle speed pulse signal cable (purple/white), parking brake cable (red/white) or reverse signal cable (green)] from the main unit and the vehicle cable into the splicing connector.

2 Push in the terminal (the metal part) of the splicing connector using a pair of pliers.

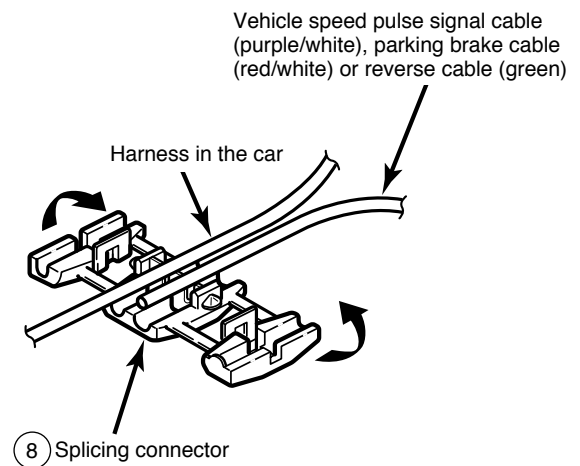

3 Press down the cover of the splicing connector and squeeze it until it locks.

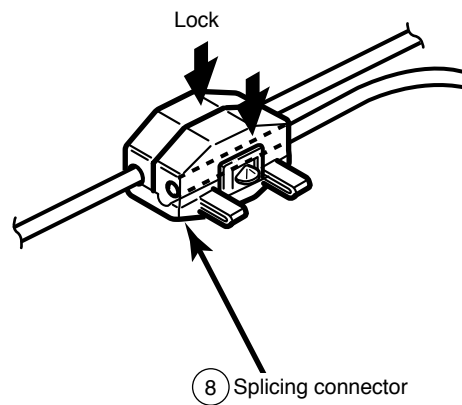

System connection example

⚠ Warning

- Never cut the insulation on the power cable or use it to power any other equipment. If the rated current capacity of the power cable is exceeded, fire and electric shocks may result.
- The cables should be secured with tape or similar item so it will not cause an obstruction while driving. If they get wound around components such as the steering wheel, shifting lever or brake pedal, accidents may result.

👉 Tip

- Install and connect all of the peripheral units before connecting them to the main unit.
- Do not remove the caps of pin jacks unless in use.
- Be sure to wrap the connection cables with plastic tape to insulate them.

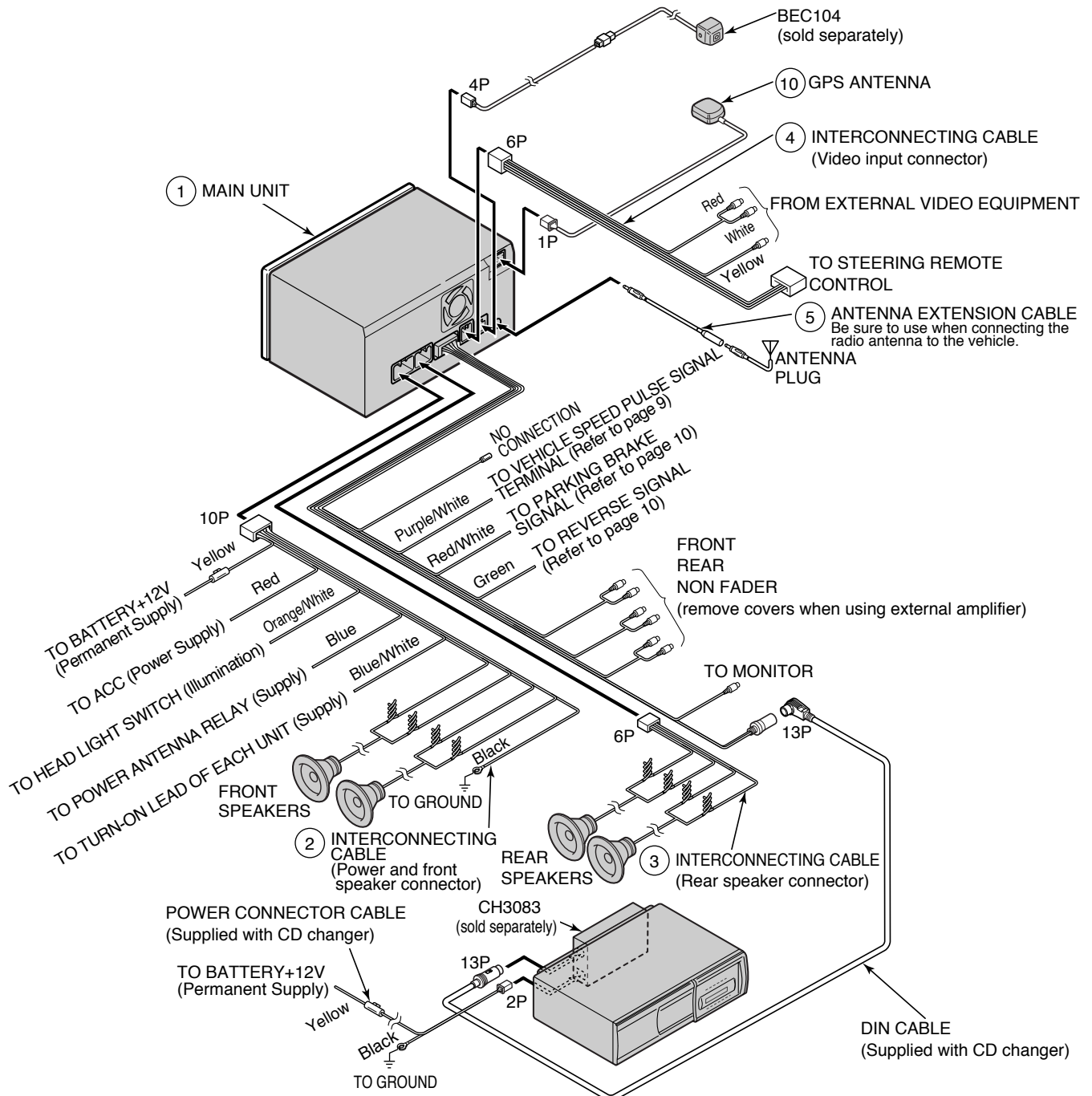

Installing the GPS antenna

Notes on installation

Warning

- The cables should be bound together with tape or similar so that they do not interfere with driving. If it becomes wound around parts such as the steering wheel, shifting lever or brake pedal, accidents may result.
- Do not install the GPS antenna where it will obstruct the driver's vision or where it will be an obstacle while driving, otherwise traffic accidents may result.

Tip

- If installing the GPS antenna inside the vehicle, be sure it is mounted to the ground plate.
- If installing the GPS antenna inside the vehicle, the location and the slope of the vehicle's windshield will determine the accuracy of the GPS antenna to receive the GPS signal. If this occurs you may want to install the antenna outside of the vehicle.
- The materials used in front and rear vehicle windows can cause GPS reception sensitivity to drop significantly. If this happens, install the GPS antenna on the outside of the vehicle.
- If the attachment surface is a non-plastic surface such as genuine leather, wood panel or cloth, attaching the antenna may damage the surface finish. Do not attach the ground plate to such surfaces.
- Wipe the installation surface thoroughly so that it is clear of any dirt, moisture or grease before installing the antenna.
- Do not apply any coatings to the GPS antenna, otherwise it may cause a drop in the reception sensitivity of the antenna.
- Route the GPS antenna cable as far away as possible from TV and radio antennas and cables, otherwise it may cause interference with video and audio signals.
- Do not install the antenna in places (such as front pillars and roof panel) that are shielded from the sky.
- The GPS antenna should be installed in a level position where the signals will be as unobscured as much as possible, such as on the vehicle's roof. Satellite signals cannot be received if the antenna is obscured.
- If installing the GPS antenna outside the vehicle, remove the main antenna unit if leaving the vehicle unattended for long periods in order to prevent theft or malicious damage to the antenna.
- Hold the main antenna unit when removing the antenna. Do not pull on the cable, otherwise it may become damaged and result in problems with correct operation.
- If installing the GPS antenna outside the vehicle, remove the main antenna unit when washing the vehicle. (If you wash the vehicle with the main antenna unit still attached, avoid spraying the cable section directly with water so that no water gets inside the vehicle.)
- The magnet that is attached to the GPS antenna is extremely strong. Be sure to note the following when installing the antenna.
 - Do not put the antenna down on the ground or on dirty or dusty surfaces. If iron filings become attached to the magnet, they may cause damage to the vehicle's body.
 - Keep the antenna away from watches and magnetic cards, otherwise they may be damaged and/or rendered unusable.

– Installation inside the vehicle (example) –

- 1 Choose an installation location on the dashboard which is flat and has a clear view of the sky.

Tip

Select a location that is at least 19.68 in. away from the main unit. If this is not done, the GPS measurement precision will drop.

- 2 Install the ground plate to the dashboard.

- 3 Install the GPS antenna to the ground plate.

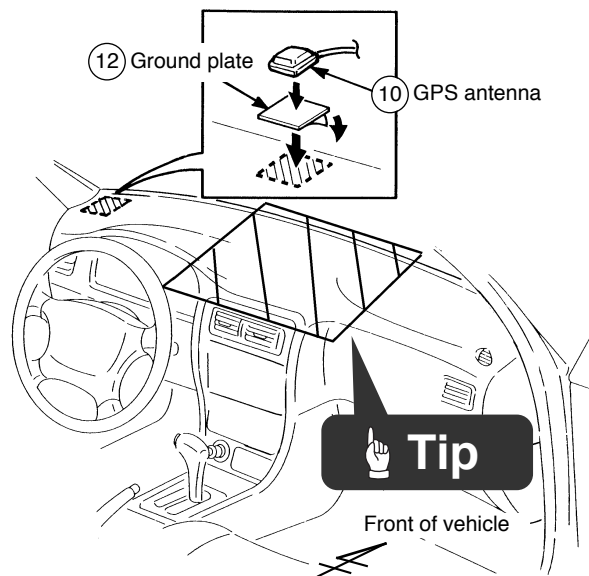

Tip

If installing the GPS antenna inside the vehicle, the installation location and the shape of the vehicle's body determine GPS accuracy. Accuracy is usually lower when the GPS antenna is installed inside the vehicle.

- 4 Secure the GPS antenna cable with clamps.

- 5 Route the GPS antenna cable along the crevice between the front windshield and the dashboard.

Tip

If the GPS antenna cable protrudes from the dashboard, wind tape around it so that it stays securely fixed in the crevice between the front windshield and the dashboard.

- 6 Route the GPS antenna to the main unit installation position.

Tip

Cut the harness fixing tape into usable lengths with scissors. Do the same for the rest of the installation.

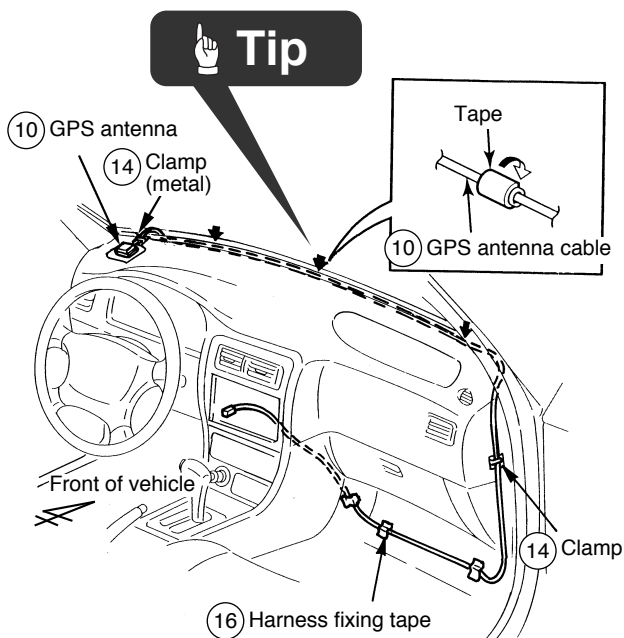

– Installation outside the vehicle (example) –

- 1 Choose an installation location where the GPS antenna can be attached securely.
- 2 Remove the backing paper from the body protective sheet and attach the sheet to the vehicle.
- 3 Install the GPS antenna on top of the body protective sheet.

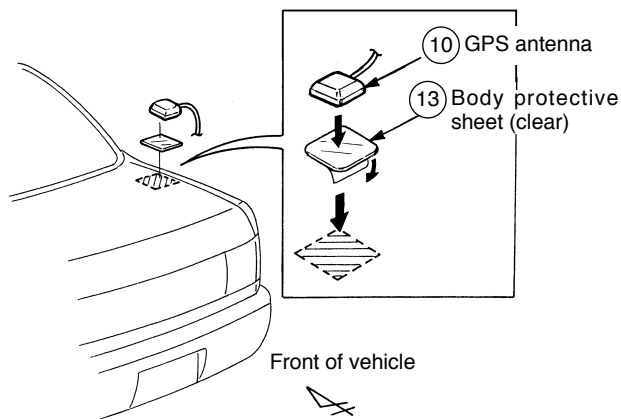

- 4 Route the GPS antenna cable inside the vehicle's trunk and secure it with clamps.
- 5 Attach the waterproof cushion so that the GPS antenna cable is flat against the weatherstrip when the trunk lid is closed.

Tip
Apply plain water or soapy water to the waterproof cushion when moving it.

- 6 Route the GPS antenna cable while securing it with cable ties.

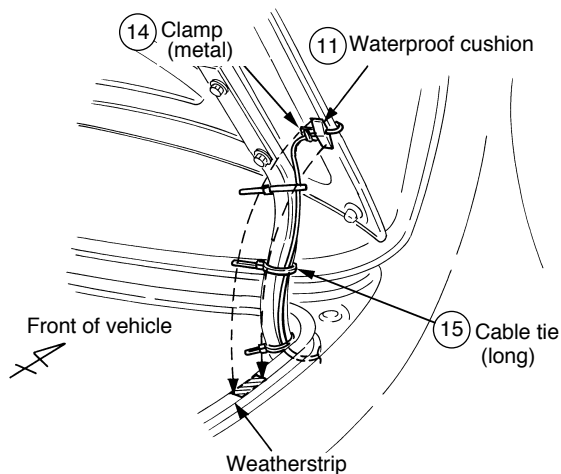

- 7 Route the GPS antenna cable to the main unit while securing it with harness fixing tape.

Tip
Cut the harness fixing tape into usable lengths with scissors. Do the same for the rest of the installation.

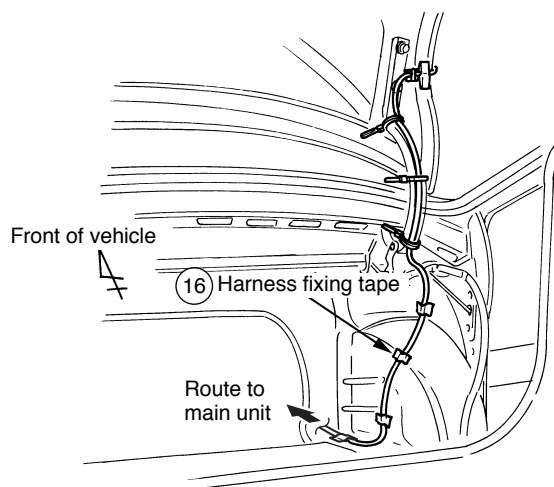

Installing the main unit

– Installation angle –

Tip

To maintain proper function, the unit must be mounted less than 30 degrees. If the angle is in excess of 30 degrees, DVD/CD skipping or ejection may occur.

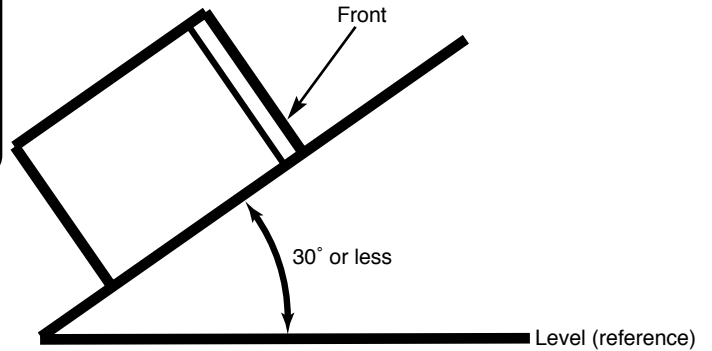

– Mounting the main unit (example) –

Tip

Connect all cables before installing the main unit.

- 1 Remove the pocket and any other accessories from the center cluster to make room for the main unit.
- 2 Remove the mounting brackets for the pocket.

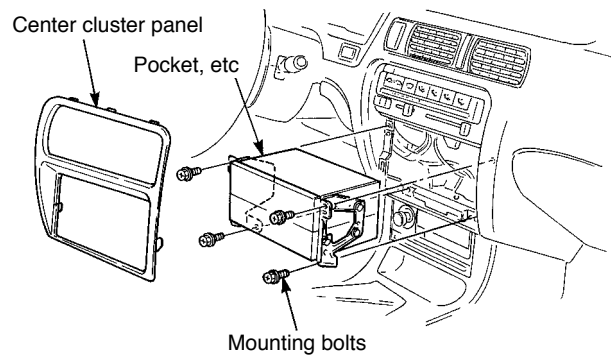

- 3 Attach the brackets to the main unit.
- 4 Install the main unit in the vehicle.

Tip

Be sure to use the accessory screws (M5x8) to install.

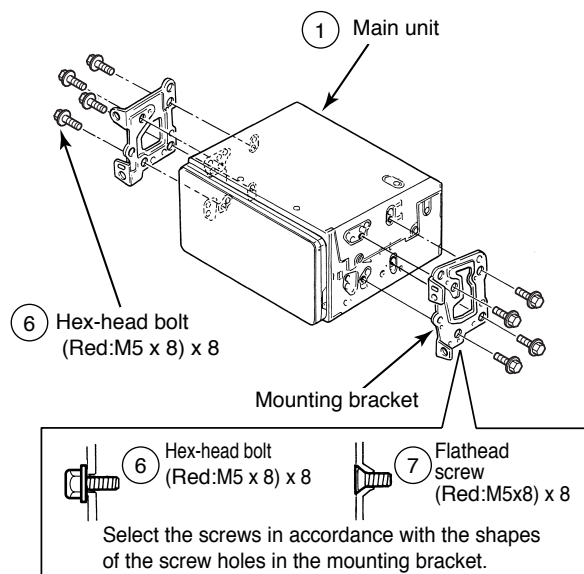

**“ECLIPSE” is a registered trademark of
FUJITSU TEN LIMITED in 48 countries
including the U.S. and Japan.**