



## DSA1035

### QUICK START GUIDE

DVD Multimedia Receiver with 3.5" TFT LCD Display

This Quick Start Guide gives you the basics to start using your DSA1035. Please visit [www.dualav.com/support/manuals/DSA1035.pdf](http://www.dualav.com/support/manuals/DSA1035.pdf) to download a complete Owner's Manual or call customer service at 1-866-382-5476.



Customer Service Toll Free: 1-866-382-5476

#### Safety Notes:

The DVD video display of the in-dash unit will not operate while the vehicle is moving. This is a safety feature to prevent driver distraction. In-dash DVD video functions will only operate when vehicle is in Park and the parking brake is engaged. It is illegal in most states for the driver to view video while the vehicle is in motion.

## Installation

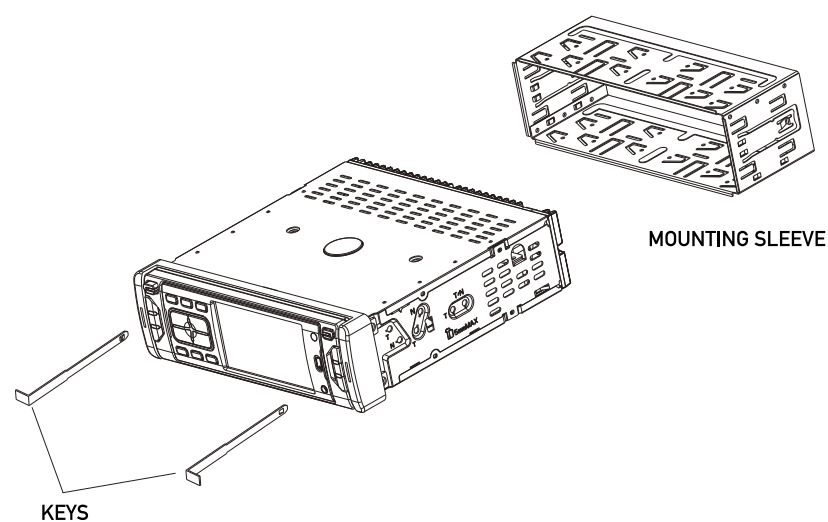

#### Copyright and Trademark Notes

This product incorporates copyright protection technology that is protected by method claims of certain U.S. patents and other intellectual property rights owned by Macrovision Corporation and other rights owners. Use of this copyright protection technology must be authorized by Macrovision Corporation, and is intended for home and other limited viewing uses only unless otherwise authorized by Macrovision Corporation. Reverse engineering or disassembly is prohibited. Manufactured under license from Dolby Laboratories. Dolby and the double-D symbol are trademarks of Dolby Laboratories. DVD Logo is a trademark of DVD Format/Logo Licensing Corporation registered in the U.S., Japan and other countries. SD Logo is a trademark of SD-3C, LLC. Other trademarks and trade names are those of their respective owners.

## Wiring Diagram – Inputs/Outputs

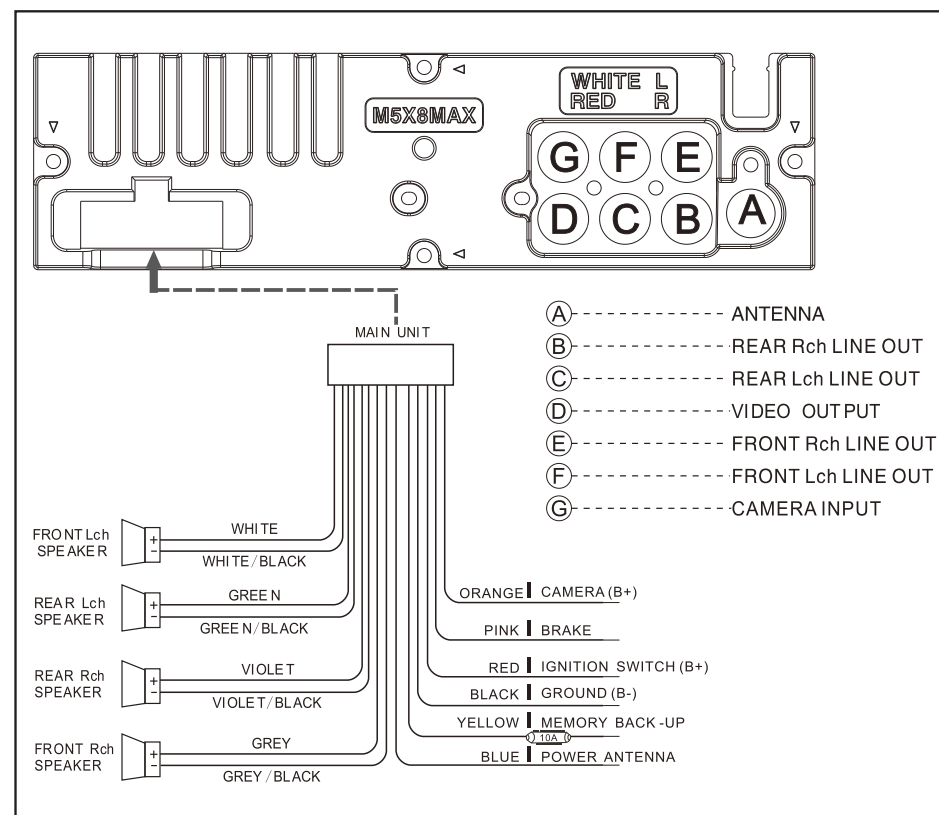

## Control Locations

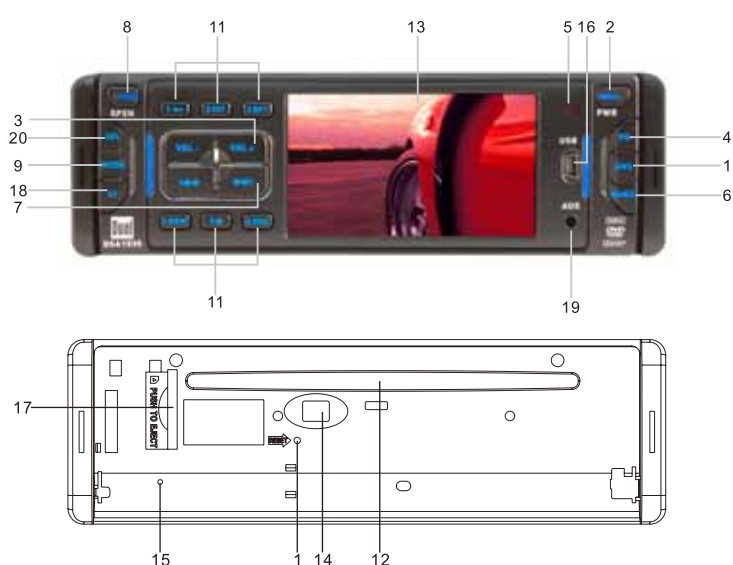

- |                       |                     |
|-----------------------|---------------------|
| 1. Reset              | 11. Presets         |
| 2. Power              | 12. Disc Slot       |
| 3. Volume Up/Down     | 13. TFT LCD Display |
| 4. EQ/Mute            | 14. Eject           |
| 5. Remote Eye Sensor  | 15. Security LED    |
| 6. Band /ID3 tag      | 16. Mini-USB Input  |
| 7. Tune/Track Up/Down | 17. SD Slot         |
| 8. Open               | 18. Mono/Stereo     |
| 9. Mode               | 19. AUX Input       |
| 10. AMS               | 20. Select          |

## Remote Control

- |                         |                               |
|-------------------------|-------------------------------|
| 1. Power                | 15. Audio                     |
| 2. Mode                 | 16. Goto                      |
| 3. Play/Pause           | 17. EQ                        |
| 4. Mute                 | 18. Number keys               |
| 5. Title                | 19. PBC                       |
| 6. Subtitle             | 20. OSD                       |
| 7. Setup                | 21. Local /Random             |
| 8. Angle                | 22. Seek Down /Previous Track |
| 9. Slow                 | 23. AMS/RPT                   |
| 10. Volume UP           | 24. Stereo/Program            |
| 11. Zoom                | 25. Stop                      |
| 12. Select              | 26. Enter                     |
| 13. Seek UP /Next Track | 27. Band/System               |
| 14. Volume Down         |                               |

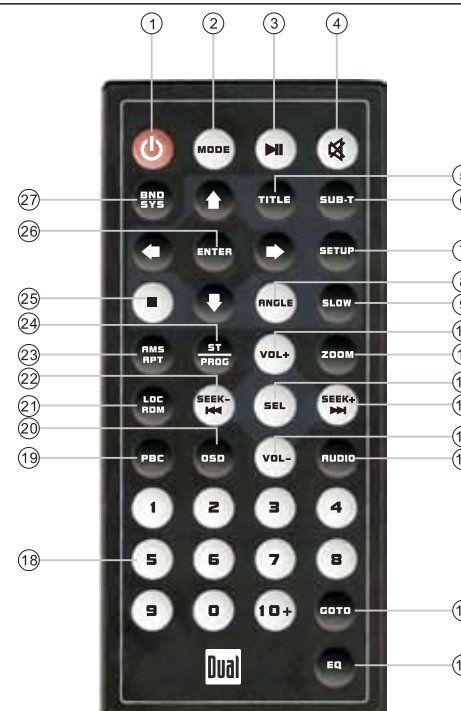

## Audio Setup

From any mode, press "SEL" until AUDIO SETUP is displayed. Press "◀" or "▶" to select desired parameter and adjust the level by pressing "VOL+" or "VOL-".

AUDIO SETUP	
BASS	+2
TREBLE	+2
BALANCE	0
FADER	0
EQ	FLAT
LOUD	OFF
SUB	OFF

## Video Setup

From video playback mode, press "SEL" until VIDEO SETUP is displayed. Press "◀" or "▶" to select desired parameter and adjust the level by pressing "VOL+" or "VOL-".

VIDEO SETUP	
BRIGHTNE	33
CONTRAST	33
SHARPNESS	2
COLOR	30
HUE	30

## System Setup

From any mode, press "SEL" until SYSTEM SETUP is displayed. Press "◀" or "▶" to select desired parameter and adjust the level by pressing "VOL+" or "VOL-". To rest the unit to the default settings, press "◀" or "▶" to select "RESTORE" and press "VOL+" or "VOL-" to confirm.

SYSTEM SETUP	
DISP	ON
CLOCK	00:00
LOC	OFF/ON
ST	ON/OFF
AREA	SA
DEFAULT	RESTORE

## Limited One Year Warranty

This warranty gives you specific legal rights. You may also have other rights which vary from state to state.

Dual Electronics Corp. warrants this product to the original purchaser to be free from defects in material and workmanship for a period of one year from the date of the original purchase.

Dual Electronics Corp. agrees, at our option, during the warranty period, to repair any defect in material or workmanship or to furnish an equal new, renewed or comparable product (whichever is deemed necessary) in exchange without charges, subject to verification of the defect or malfunction and proof of the date of purchase. Subsequent replacement products are warranted for the balance of the original warranty period.

**Who is covered?** This warranty is extended to the original retail purchaser for products purchased from an authorized Dual dealer.

**What is covered?** This warranty covers all defects in material and workmanship in this product. The following are not covered: software, installation/removal costs, damage resulting from accident, misuse, abuse, neglect, product modification, improper installation, incorrect line voltage, unauthorized repair or failure to follow instructions supplied with the product, or damage occurring during return shipment of the product. Specific license conditions and copyright notices for the software can be found via [www.dualav.com](http://www.dualav.com).

#### What to do?

- Before you call for service, check the troubleshooting guide in your owner's manual. A slight adjustment of any custom controls may save you a service call.
- If you require service during the warranty period, you must carefully pack the product (preferably in the original package) and ship it by prepaid transportation with a copy of the original receipt from the retailer to an authorized service center.

3. Please describe your problem in writing and include your name, a return UPS shipping address (P.O. Box not acceptable), and a daytime phone number with your shipment.

4. For more information and for the location of the nearest authorized service center please contact us by one of the following methods:

- Call us toll-free at 1-866-382-5476
- E-mail us at [cs@dualav.com](mailto:cs@dualav.com)

**Exclusion of Certain Damages:** This warranty is exclusive and in lieu of any and all other warranties, expressed or implied, including without limitation the implied warranties of merchantability and fitness for a particular purpose and any obligation, liability, right, claim or remedy in contract or tort, whether or not arising from the company's negligence, actual or imputed. No person or representative is authorized to assume for the company any other liability in connection with the sale of this product. In no event shall the company be liable for indirect, incidental or consequential damages.