

3
SERIES

ORLANDO CM127

4 X 30 WATTS POWER

BLAUPUNKT



Cassette Receiver with CD Changer Control

Autoradio à cassette et contr le de changeur CD

Receptor con Cassette y Control Cambiador de CD

Rádio-Cassete com Contr le para Cambiador CD

● BLAUPUNKT.

Bosch Group

FCC Warning

The equipment has been tested and found to comply with the limits for a Class B device, pursuant to Part 15 of the FCC Rules. These limits are designed to provide reasonable protection against harmful interference in a residential installation. This equipment generates, uses, and can radiate radio frequency energy, and, if not installed and used in accordance with instructions, may cause harmful interference with radio communications. However, there is no guarantee that radio interference will not occur in particular installation. If this equipment does cause harmful interference to radio or television reception, which can be determined by turning the equipment off and on, the user is encouraged to contact the dealer or an experienced Radio/TV technician for help.

You are cautioned that any changes or modifications not expressly approved in this manual could void your authority to operate this equipment.

Owner's Record

The model and warranty numbers are located on the top of the unit. Record the warranty (serial) number in the space provided below. Refer to these numbers whenever you call upon your Blaupunkt dealer regarding this product.

Warranty Number _____

Attach Sales Receipt Here

Table of Contents

English

FCC Warning	2
Owner's Record	2
Features	4
Precautions	4
Detachable Face	5
Electrical Connections and Installation	6
Installation	8
Maintenance	10
Specifications	11
Location of Controls	12
Instructions—General Operation	12
Audio Operation	13
Radio Operation	14
Cassette Tape Player Operation	15
CD Changer Control	16
Troubleshooting Guide	17

Français

Avertissement de la FCC	20
Archive du Propriétaire	20
Caractéristiques	21
Précautions à Prendre	21
Face Avant Amovible	22
Raccordements Électriques et Installation	23
Installation	25
Entretien	27
Spécifications	28
Emplacements des Commandes	29
Mode d'Emploi/Fonctionnement Général	29
Fonctionnement de la Audio	31
Fonctionnement de la Radio	31
Fonctionnement du Lecteur de Cassette	32
Commande du Changeur	33
Guide de Dépannage	35

Español

Advertencias FCC	36
Registro del Propietario	36
Características	37
Precauciones	37
Panel Frontal Desmontable (Carátula)	38
Conexiones Eléctricas e Instalación	39
Instalación	40
Mantenimiento	43
Especificaciones	44
Ubicación de los Controles	45
Instrucciones de Funcionamiento	45
Funcionamiento de Audio	46
Funcionamiento de la Radio	47
Funcionamiento de Reproductor de Cassette	48
Control de Cambiador	49
Guía para la Solución de Problemas	50

Portuguese

Aviso da FCC	51
Registro do Proprietário	51
Características	52
Precauções	52
Painel Removível	53
Conexões Eléctricas e Instalação	54
Instalação	56
Manutenção	58
Especificações	59
Posição dos Controles	60
Instruções-Funcionamento Geral	60
Funcionamento do Audio	61
Funcionamento do Rádio	62
Funcionamento do Toca-Fitas	63
Controle de Cambiador	64
Guia para Solução de Problemas	66

Features

Congratulations on your purchase of this Blaupunkt Cassette Receiver. Its Codem III-US FM/AM Tuner and Autoreverse Cassette Tape Player mechanism provide the ultimate in radio sound reproduction. Its high-power amplifier and 4-Channel preamp output provide you with tremendous system configuration flexibility. Its ability to control the Blaupunkt CDC-A05 and CDC-A071 CD Changers lets you easily incorporate CD sound into your car's sound system.

- Codem III-US Tuner Features:
 - Multipath Management
 - ASU Electrical Impulse Noise Reduction
 - Superior AM Frequency Response
 - 15 FM/5 AM Presets, Including 5 FM & 5 AM Travel Store Presets
 - Station Scan
 - Local/Distant Seek & Manual Tuning
- Cassette Tape Player Features
 - Auto-Reverse Cassette Mechanism
 - True Fast-Forward/Rewind
 - Hard Permalloy Tape Head
 - Radio Monitor with Radio Preset Access
 - Dolby B Noise Reduction
- CD Changer Control Features
 - Controls CDC-A071 Changer or CDC-A05 Changer
 - Disc Select & Track Up/Down
 - Audible Cue/Review
 - Pause/Play
 - Disc/Track Scans, Repeat and Mix
 - Last Position Memory
- Audio Features:
 - 30 Watts x 4 Channel Integrated Amplifier
 - Dual-Level Fader
 - Over 3 Volts of Distortion-Free Preamp Output
 - 4-Channel, Low Impedance (100 Ω) Preamplifier
 - 2-Channel RCA Preamp Output Harness Included
 - Bass, Treble, Balance, Fader Controls
 - Adjustable Maximum Turn-On Volume
 - Loudness Button
 - Mute Button
- Other Features:
 - Partially Detachable Face
 - Green Illumination
 - Display Priority Control
 - Temporary Display Change Control
 - Clock/Ignition-Off Clock Recall
 - 180 x 50 x 155 mm (7 x 2 x 6 1/8 in.) DIN/ISO Chassis
 - Detachable Wire Harness
 - Snap-In DIN Sleeve & Mounting Hardware
 - Side-Bracket Compatible

Your unit's detachable front faceplate makes the unit useless to would-be thieves.

Designed, Engineered and Manufactured by Blaupunkt

Traffic Safety and Precautions

- Do not adjust your unit in difficult driving conditions that demand your full attention.
- As the driver of a motor vehicle, it is your responsibility to pay attention to the traffic situation at all times. Never use your unit in a way that could distract you.
- Always make sure that you are still able to hear any warning signals coming from outside of the vehicle, such as police or fire engine sirens, so that you can react accordingly.
- If your vehicle was parked in direct sunlight resulting in a considerable rise in temperature inside the vehicle, allow the unit to cool off before operating your unit.
- You are cautioned that any changes or modifications not expressly approved in this manual could void your warranty.

Detachable Face

Detaching & Attaching the Face:

The face of this unit can be detached and taken with you to prevent it from being stolen.

Detaching the Face:

Press the REL (Release) Button and detach the face by gently pulling it off as illustrated.

Note: Do not pull it straight out from the chassis. Be sure not to drop the face when detaching it from the chassis.

Attaching the Face:

Apply the right hand side of the face to the chassis by sliding (part B) of the face to (part A) at the front of the chassis. Gently push the left side of the face against the front of the chassis until it snaps into place.

Note: Make sure that the face is inserted right side up. Do not press against the display window. Do not press hard against the face when attaching it to the chassis, it may be easily attached with gentle pressure. Do not expose the face to direct sunlight, heat sources such as hot air ducts or leave it in a humid place. Never leave it on the dash board of a vehicle parked in direct sunlight, where there may be a considerable rise in temperature inside the vehicle.

Affixing Faceplate For Retail Display:

The faceplate can be affixed to the unit's chassis, which is desirable for a retail display, for example.

To affix the faceplate:

Insert the black bolt into the hole at the left front of the top of the radio. See* below.

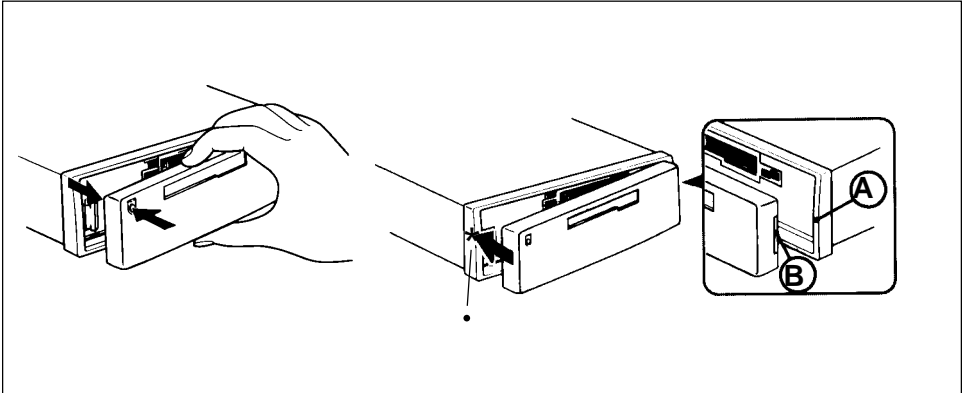

Electrical Connections and Installation

@/<?#&*>@!To avoid the aggravation of costly mistakes and serious damage that could make you feel this way, please carefully read all of the instructions before you begin. Carefully follow all instructions. You'll be glad you did!

GENERAL RECOMMENDATIONS

- If you're not confident that you can install the unit correctly, have it installed by a qualified Blaupunkt installation technician.
- Use this unit only with negative ground 12 Volt (11-16 Volt) direct current (DC).
- Be sure to detach the faceplate before you start to connect or install the unit.
- Don't assume that a seemingly matching wire harness in the vehicle has leads that match the leads of the unit's wire harness.
- We recommend making and testing all electrical connections before installing the unit. Connect the leads (wires) according to instructions and diagram below.

IF YOU ARE INSTALLING A COMPATIBLE BLAUPUNKT CD CHANGER

- For speaker connection, use the speaker wire harness section that comes with the receiver.
- For other connections, use the wire harness sections that come with the CD Changer, not the receiver.
- Note that some of the CD Changer's wire harness leads have different colors:
 - In place of yellow lead, use red lead that has yellow BATT. clip for constant power.
 - In place of black lead, use brown lead for ground.
- If both a changer and an external amplifier are to be connected, connect the changer's blue lead, not the blue/white lead, to the amplifier's trigger switch.

The changer harness also has gray, blue/white, and orange leads that are non-functional with this receiver.

ELECTRICAL CONNECTION INSTRUCTIONS

1. Disconnect the vehicle battery's negative terminal before making connections.
2. Connect the speakers and/or external amplifiers (if you have any) following the guidelines in the SPEAKER CONNECTION section below.
3. Connect the blue (trigger output) lead to an amplifier's trigger input terminal and/or antenna motor trigger input terminal (if you have either or both of these items). The combined total amperage required for triggering the antenna motor and/or amplifier must not exceed 300 mA. DO NOT connect the blue lead to the antenna's and/or amplifier's power supply input.
4. Connect the black (power ground) lead to a grounded metal part on the vehicle. We recommend grounding all audio system black ground leads (head unit, external amplifier, etc.) to a common grounding point, preferably a non-painted surface under the instrument panel.
5. Connect the yellow (constant power) input lead to a source of constant battery power, preferably a terminal to an appropriate slot in the fuse box.
6. Connect the red (turn-on power) input lead only after the other leads are connected. Be sure to connect the red lead to a positive (+) 12 Volt power terminal that is energized only when the ignition key is set to the on position or accessory position.
7. Cover the ends of any unused leads with electrical tape. This will prevent them from touching the vehicle or each other and causing a short-circuit and damage to the radio or vehicle.
8. Reconnect the vehicle's battery.
9. Verify that no fuses have blown.
10. Plug the harness into the unit.
11. Attach the faceplate and test the unit.

Once the connections have been successfully made, you can begin to mount the unit.

SPEAKER CONNECTIONS

he unit's Dual-Level Fader allows you to fade between the front and the rear channels using either the front and/or rear speaker leads and/or the rear preamp outputs, providing you tremendous flexibility in configuring your speaker arrangement:

- You can connect a speaker (regular, co-axial or tri-axial speakers or component speaker system, all hereafter referred to simply as "speaker") to each of the units' four pairs of speaker leads.

- You can connect the 2 RCA preamp outputs to multiple external amplifiers and power multiple speakers or speaker systems through the amplifiers. (Blaupunkt amplifiers and speakers available separately). To add front preamp output, purchase Blaupunkt part 8 634 494 218, which is included in the CDC-A05 and CDC-A071 changer's harnesses.
- You can use a either or both of these two methods.

Connecting the Speaker Leads

To prevent short circuits or serious damage to the unit and/or speakers:

- Connect the speaker leads only as indicated in the wiring diagram. Disconnect the vehicle battery's negative terminal before making connections.
- Only use speakers that have impedance ratings of 4 ohms or higher and have power-handling capabilities greater than the unit's stated power level.
- The unit's internal amplifier is designed to handle a 4-ohm load on each pair of speaker leads.
- DON'T connect two speakers to a single pair of speaker leads ("in parallel") unless both speakers each have at least 8 ohms impedance.
- DON'T connect the left and right speaker leads to each other or to the same speakers.
- DON'T connect the front and rear speaker leads to each other or to the same speakers.
- DON'T connect the negative speaker leads to each other.
- DON'T connect the positive speaker leads to each other.
- DON'T connect any active speakers (with built-in amplifiers) to the speaker leads unless their owner's manuals specifically state that this is O.K.
- Cover the ends of any unused leads with electrical tape. This will prevent them from touching the vehicle or each other and causing a short-circuit and damage to the receiver or vehicle.

Connecting the Pre-Amp Outputs to External Amplifier(s)

To prevent short circuits or serious damage to the receiver, amplifier, and/or speakers:

- Follow the amplifier's instructions on how to connect the unit's preamp outputs to the amplifier(s) and connect the speaker(s) directly to the amplifier.

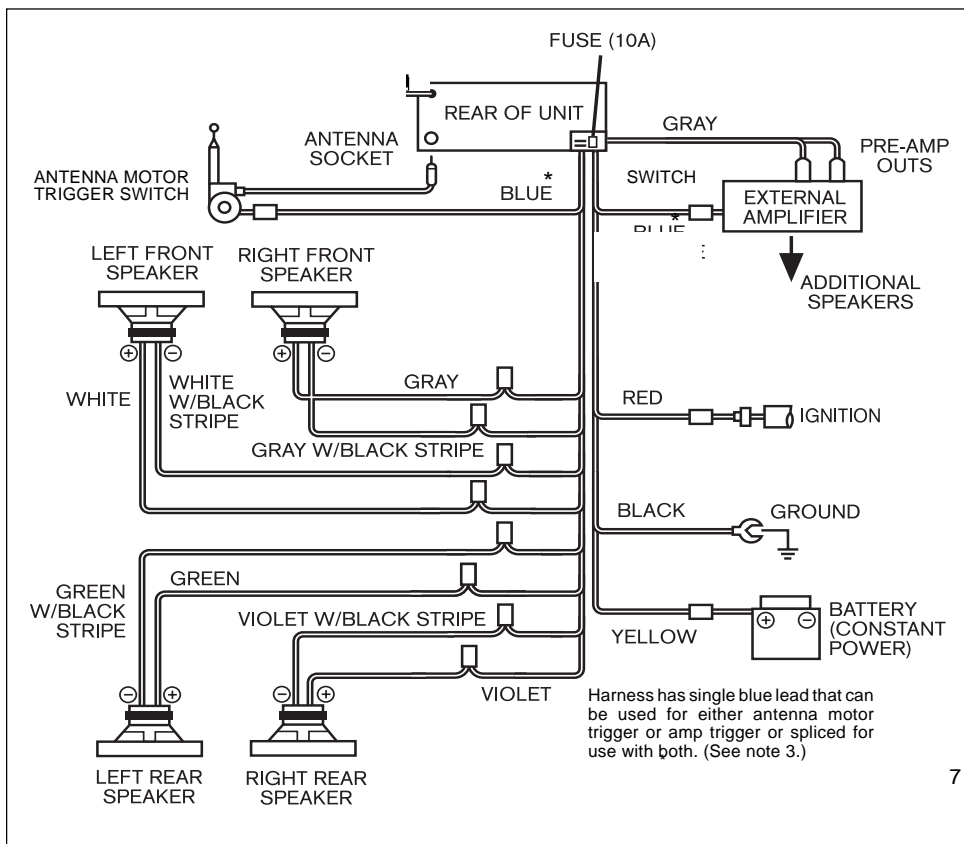

Installation

Recommendations

- Carefully choose the mounting location so that the unit won't interfere with normal driving.
- Avoid mounting locations where the unit would be subject to high temperatures, such as from direct sunlight or hot air from the heater, or where it would subject to dust, dirt or excessive vibration.
- The illustration below shows a typical installation, however, you may need to adjust the installation, depending on the unit. If you have questions or need additional installation hardware, consult your Blaupunkt dealer.
- Make sure the unit is firmly anchored (preferably at both front and back) and does not vibrate

Mounting Hardware

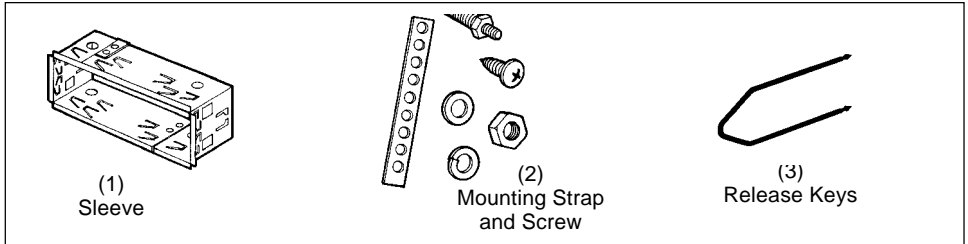

Mounting The Unit in Most Dashboards

- 1 Install the Sleeve (1) in the dashboard.
- 2 Select and bend the appropriate tabs to hold the sleeve firmly in place.
- 3 A. Attach the Mounting Strap (2) to the underside of the dashboard, using screw.
B. Attach the back of the unit to the mounting strap using the support stem bolt and hardware.

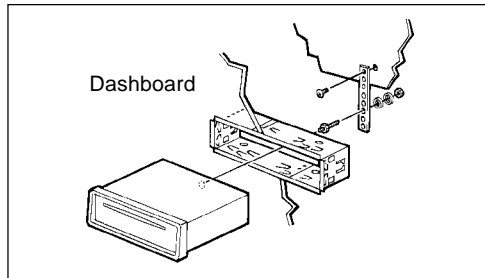
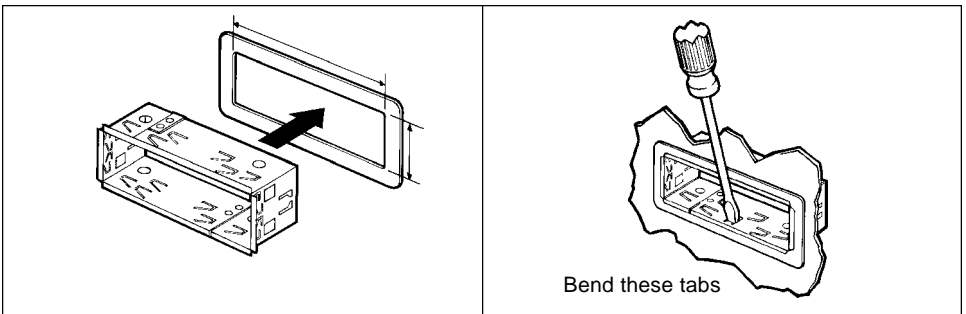

Mounting the Unit in a Japanese Car

You may have difficulty mounting this unit in some Japanese cars that have ISO mounting features (side-bracket mounting systems). In this case, consult your Blaupunkt dealer.

- 1 Run a blade along the slits on the back of the front trim ring, unscrew the two side screws, and separate it from the unit. Save the trim ring and related hardware in case you ever want to install the unit in another vehicle.
- 2 Use the vehicle's own mounting hardware to attach the unit.

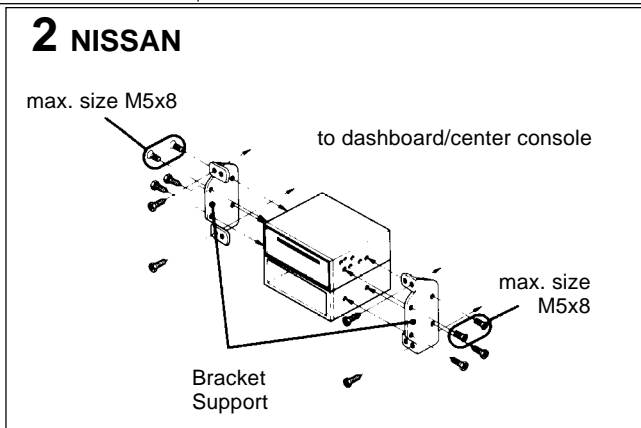
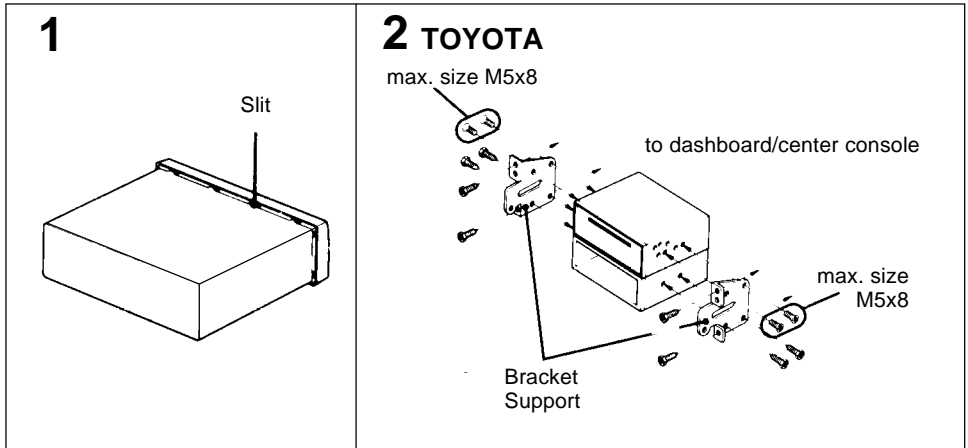

Maintenance

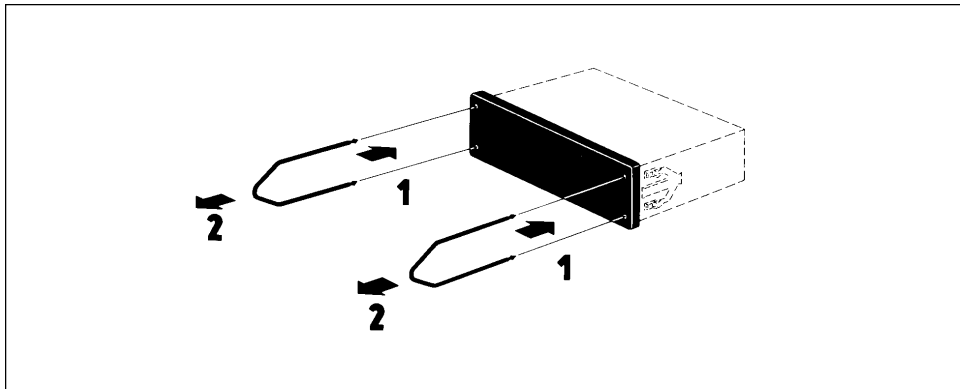

Removing the Unit

Use the Release Keys as shown below. Keep them in a safe place in case you need them in the future.

Fuse Replacement

When replacing the fuse, be sure to use one with the correct amperage, which will be stated on the fuse case. Never use a fuse that has a stated amperage exceeding the one supplied for this unit, as this could cause malfunction and serious damage to the unit.

Specifications

Audio Power Specifications

Power Output and Total Harmonic Distortion: 13 watts per channel minimum continuous average output into 4 ohms, 4 channels driven, from 30-15,000 Hz with no more than 1% total harmonic distortion.

Other Specifications

Tuner

FM

Tuning Range:	87.5 - 107.9 MHz
Intermediate Frequency:	10.7 MHz
FM Mono Sensitivity:	13 dBf
Seek lo sensitivity:	51 dBf
Seek sensitivity	31 dBf
Selectivity:	80 dB at 400kHz
Signal-to-Noise Ratio:	65 dB (stereo), 70 dB (mono)
Harmonic distortion at 1 kHz:	0.7% (stereo), 0.5% (mono)
Separation:	30 dB
Frequency Response:	30-15,000 Hz \pm 3 dB

AM

Tuning Range:	530 - 1,710 kHz
Seek lo sensitivity	50 dB μ V
Seek sensitivity:	25 dB μ V
Intermediate Frequency:	450 kHz
Signal-to-Noise Ratio:	50 dB
Frequency Response:	30-5,000 Hz \pm 3dB

Audio

Speaker Impedance:	4-8 ohms
Maximum Amp Power:	4 X 30 Watts (at 4 ohms)
RMS Power:	4 X 13 Watts (at 4 ohms) <1% THD
Bass Control:	\pm 10 dB @ 100 Hz
Treble Control:	\pm 10 dB @ 10 kHz
Loud:	+ 8 dB @ 60 Hz & + 2 dB @ 8 kHz
Preamp Output:	4-Channel, Low-Impedance (100 Ω) Preamplifier Over 3 Volts of Distortion-Free Preamp Output

Cassette

Signal-to-Noise Ratio:	55 dB
with Dolby B Noise Reduction:	65 dB
Tape Wow and Flutter:	0.10% dB
Tape Frequency Response:	30-18,000 Hz \pm 3 dB

General

Dimensions (w/o projecting parts/controls):	180 x 52 x 155 mm, 7 x 3 x 6 ¹ / ₈ in.
Mass:	Approx. 1.4 kg (3.0 lb.)
Power Requirement (neg. grnd.):	12 V DC car battery (11-16 V DC allowable)
Operating Temperature:	15°F to 120°F, -10°C to 50°C
Supplied Accessories:	<ul style="list-style-type: none">• Unit• Faceplate• Wire Harness, including 2-Channel RCA Preamp Output Harness• DIN Sleeve• Mounting Hardware• Owner's Manual in English, French, Spanish and Portuguese
Optional Accessories:	<ul style="list-style-type: none">• 4-Channel Preamp Output Harness (Part No. 8634494218)• CDC-A05 or CDC-A071 CD Changers

Design and specifications subject to change without notice.

Location of Controls

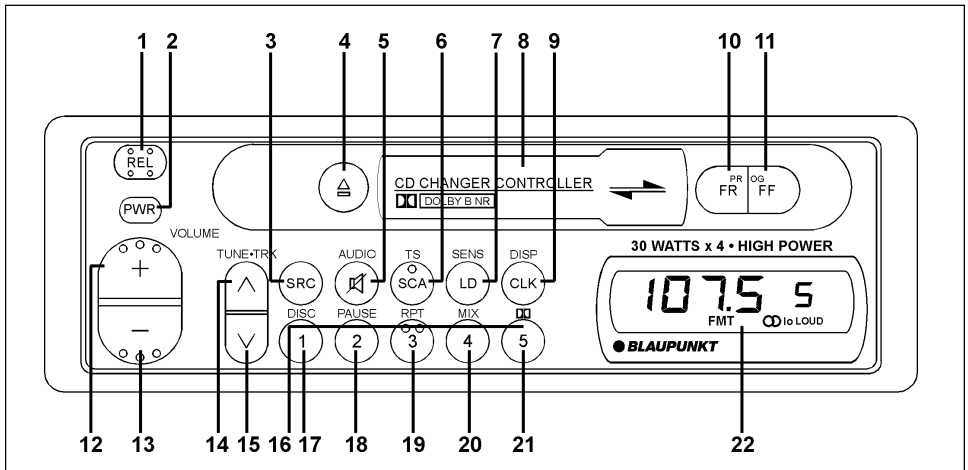

- | | |
|--|---|
| <ol style="list-style-type: none"> 1. REL (Release) Button 2. PWR (Power) Button 3. Source (and Radio Band) Select 4. Cassette Eject 5. Mute/ Audio Button/ Clock Adjust:00 6. SCA (Scan) TS (Travel Store) 7. LD (Loudness)/ SENS (Tuning Sensitivity) 8. Cassette Insertion Slot 9. CLK/Display Change 10/11. Tape Program Change (reverse) 10. Fast Rewind 11. Fast Forward 12. + Button
Volume +
Bass +
Treble + 13. - Button
Volume -
Bass -
Treble - | <ol style="list-style-type: none"> Balance Right Fade to Rear 14. ^ Button
Seek and Manual Tuning
CD Track Up
Audible CD Cue
Clock Hours 15. v Button
Seek and Manual Tuning
CD Track Down
Audible CD Review
Clock Minutes 16. FM/AM Presets 17. Disc Select 18. CD Pause 19. CD Repeat 20. CD Mix 21. Dolby B Noise Reduction 22. Display |
|--|---|

Instructions — General Operation

See Traffic Safety & Precautions on page 4.

“Press” means a momentary press of less than 1/2 second. All presses requiring more than 1/2 second are followed by beep.

“Time Out” When additional button presses are anticipated to complete a procedure, the unit will automatically exit the procedure after 4 seconds of inactivity.

Ignition-Off Clock Recall

Any button press while ignition off displays time for about 8 seconds.

Ignition-On

Unit lights up and clock is displayed.

Release for Detachable Faceplate

Push REL to detach face. Already-inserted cassette remains in unit. Current settings and source mode are stored. If power was not switched off before face removed, unit will automatically power-on when face is reattached.

Power (PWR) On/Off

When ignition on, press PWR or insert a disc to turn unit on. Last-used source becomes active, unless unit is turned on by inserting tape, in which case tape player becomes active.

Power Off

Press PWR to turn unit off. Unit stores current settings for source, station or track, etc. Antenna/amplifier trigger wire shuts off voltage. (If faceplate still attached, display switches to clock.)

Setting the Clock

Turn the unit on. Press the CLK Button for four seconds until the clock starts blinking. (The display will change after two seconds. Ignore this and continue to hold for two more seconds.) Once the clock starts blinking, Press the \wedge to set the hour, and press the \vee Button to set the minutes. (To change the minute indicator to the nearest hour (:00), you can press the MUTE Button. Press the CLK Button again to activate the clock.

Changing the Information Displayed

The display priority choices are clock or functional information (radio frequency, "TAPE 1 or 2", and Track Number/Disc Number for changer.

- To change the display priority, press the CLK Button for two seconds. The display priority changes. The display priority choices are clock or radio frequency/"TAPE"/Track No. and Disc No.
- To change the display temporarily, press and release the CLK Button to access the desired information. After *four* seconds, the display changes back to the priority information.

Source (SRC)

Use SRC to select source - AMT, FM1, FM2, FMT Cassete (if already inserted), and/or CD Changer (if connected).

Audio Operation

Volume Control Buttons (+/-)

Press +and - to increase/decrease volume from 0 to 63, in increments of 1.25 dB/step. Volume control is accessible from all modes except Bass, Treble, Balance and Fade modes.

Adjustable Maximum Turn-On Volume

First adjust the volume to the (maximum) volume level desired when the unit is turned on. Press and hold the PWR Button for more than two seconds. The unit turns off and the turn-on volume level is memorized. When the unit is turned on, the volume will be at the memorized level, even if the unit was turned off while the volume was at a higher level. However, if the volume is turned off when the volume level is lower than the stored Turn-On volume level, the volume will be at the lower level when the unit is turned back on.

Mute

Press Mute to temporarily reduce volume by 20 dB. "MUTE" appears. Mute is terminated by pressing any button.

Bass, Treble, Balance and Fade

Press Mute/AUDIO for more than 1/2 second to access Bass. Subsequent presses access Treble, Balance and Fade modes.

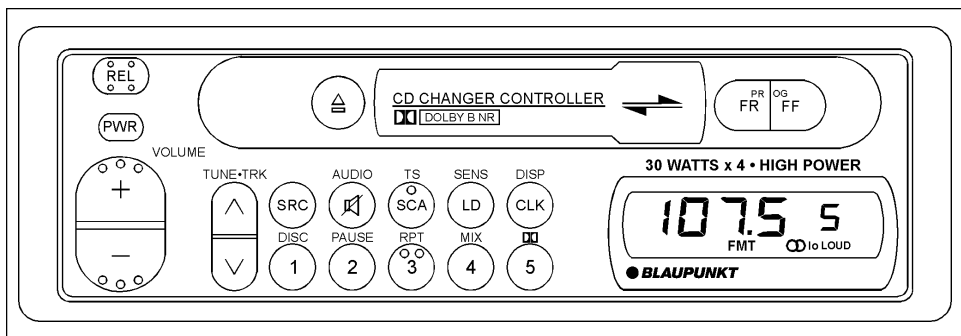

- Bass - Adjust from +7 to -7 at 2 dB/step using + to increase bass, - to decrease.
- Treble - Adjust from +7 to -7 at 2 dB/step using + to increase treble, - to decrease.
- Balance - Adjust balance from 9 (all the way left) using + to -9 (all the way right) using -.
- Fader - Adjust fader from 9 (sound only from the front) using + to -9 (sound only from the rear) using -.

Loudness (LD)

Press LD to increase sound of low and high frequencies. LOUD icon appears. To cancel, press LD again.

Radio Operation

Last Station Memory

Each FM bank and AM band has its own last station memory which holds last-tuned frequency for that band or bank irrespective of whether that frequency is stored into a preset.

Selecting Bands

Press SRC as needed to access FM1, FM2, FM3/FMT, AM/AMT banks.

Seek Tuning

Press \wedge or \vee to seek next receivable frequency. Tuning stops at frequency that fulfills sensitivity requirements predetermined by sensitivity set through SENS/LD button.

Tuning Sensitivity (SENS)

Press SENS/LD for more than 2 seconds to switch between local (lo) and distant search sensitivity. When "lo" is absent from the display, search sensitivity setting is distant.

Radio Reception Hints

- When listening to weak or distant AM stations, adjusting the Treble to minimum (-7) will reduce noise and improve sound.
- In general, set SENS to distant tuning if in rural areas or where stations tend to be weak and distant, and to local tuning when in metropolitan areas or areas where stations tend to be strong and local.

Stereo Symbol

Stereo symbol turns on if a stereo station with an incoming signal of at least 20 dB μ V is received. The unit gradually switches between mono to stereo automatically.

Manual Tuning

Press \wedge or \vee for more than 1/2 second and frequency will go one channel/step in direction pressed. Press and hold causes continuous manual tuning. Unit returns to seek tuning mode after 4 seconds or after storing a station on a preset.

Preset Station Storage

After tuning desired frequency on desired band, press and hold a Preset Button for more than 2

seconds to store current frequency. Audio is muted during storage, preset number appears, and beep acknowledges storage.

Preset Station Selection

Press desired Preset Button.

Travel Store

This feature allows you to automatically store stations onto all 5 preset buttons and is especially useful when traveling outside your normal listening area. In any FM Bank, press SCA/TS for 2 seconds to activate FM Travel Store. (In AM Bank, press it for 2 seconds to activate AM Travel Store.) TS appears. Beginning at the bottom of the band, TS stores five relatively strong stations, one on each of the five preset buttons, and returns to preset 1. Pressing any tuning-related button during Travel Store process cancels search operation.

Station Scan Tuning

Press SCA. Frequency blinks (along with preset number if appropriate) during scanning. Unit stops at receivable stations for 4 seconds. Unit continuously scans until user stops scan by pressing SCA, another tuning button or SRC.

Cassette Tape Player Operation

Tape Playback:

- Insert cassette into Cassette Door. (Note: Make sure that the side of the cassette exposed is facing right and that all slack has been removed from the tape prior to insertion.)
- If ignition switch is already in "on" or accessory position, insertion of cassette will turn unit on. If unit already turned on, cassette insertion will override other audio source, such as radio. "LOAD" appears for 2 seconds. Cassette play will begin, and the display will indicate which tape program is in use, "1" or "2".
- The tape will continue to play until ejected, SRC button pressed, or unit turned off.

Ejecting The Tape

Press the eject button completely towards the face of the unit. The tape will eject. If unit is turned on, EJ will appear in the display for 2 seconds and the last-heard radio station will play.

Tape Program Change

- Automatic Change (Autoreverse): When the end of the tape is reached, the unit will automatically reverse direction and play the other side of the tape.
- Manual Change: To manually reverse tape direction, press both PROG (program) Buttons (FR & FF) at the same time.
- The change in direction and in tape program will be confirmed in the display ("1" or "2").

Fast Winding

- To Fast-Rewind the tape, press the FR Button. Tape rewinds and ◀ blinks in the display.
- To Fast-Forward the tape, press the FF Button. Tape fast-forwards and ▶ blinks in the display.
- To stop fast-winding, press the other fast winding button, FR or FF.

Radio Monitor

During tape winding, the radio will play the most-recently heard radio frequency. All frequencies stored on the current bank of preset stations are accessible during fast winding.

Dolby B Noise Reduction

Press Dolby button when playing tapes recorded with the Dolby B noise reduction system to eliminate hissing noise. The Dolby symbol appears in the display. To cancel, press again. Note: Dolby on/off not active in Fast-Winding mode (Preset 5 is instead).

Dolby noise reduction manufactured under license from Dolby Laboratories Licensing Corporation. "Dolby" and the double-D symbol are trademarks of Dolby Laboratories Licensing Corporation.

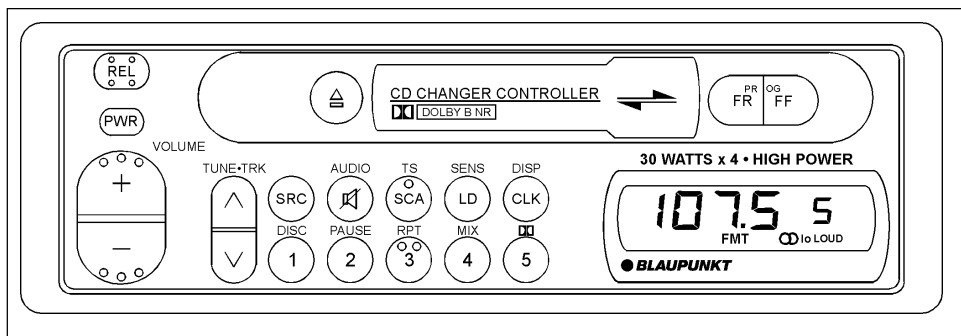

Changer Control (When optional changer is connected.)

Your receiver is ready to control a Blaupunkt CD changer with the Disc Management System, such as the CDC-A05 or CDC-A071 changers. See your Blaupunkt dealer for more information.

Activating Changer

Press SRC as many times as necessary to access Changer Mode, which is indicated in display by Track Number/Disc Number display.

Display Options

See page 13 for display options. In changer mode, the first press of DISP Button during temporary display change accesses elapsed play time display for four seconds.

Disc Select

Press DISC Button to select next disc. (When disc 10 is in use, pressing DISC Button selects disc 1.) Press and hold causes the unit to advance to advance every half second to the next disc.

Track Up/Down

Press V and ^ to select tracks. Track No. and Disc No. appear. Pressing V will restart current track if more than 1 second of track has been played. If less than 1 second has been played, unit goes to beginning of previous track. Pressing ^ in last track will select next disc.

Track Cue and Review

Press and hold ^ for audible cue. Press and hold V for audible review. Display shows elapsed play time. **Cue and Review not available in mix modes.**

Track Repeat

To play current track repeatedly, press RPT as needed until "rPT" appears. If track manually advanced, "rPT" remains active for new track.

Disc Repeat

To play current disc repeatedly, press RPT as needed until "rPTd" appears. Once all tracks on disc are played, disc is repeated. **Press of DISC will return to start of same disc.**

To cancel repeat features, press RPT as needed until "PLAY" indicator appears.

Track Mix

Press MIX as needed until "rdM" appears. This also cancels repeat or scan feature, if previously active. A track will not be played a second time (during the current playback session of a disc of 24 or fewer discs) until all tracks have been played. Once all tracks have been played, next disc is selected. **Cue and Review not available in mix modes.**

Disc Mix

Press MIX as needed until "rdMd" appears. "rdMd" randomly selects the disc after randomly playing all the tracks on the current disc. **Pressing Disc Button during "rdMd" mode returns unit to regular play. Cue and Review not available in mix modes.**

To cancel mix features, press MIX Button as needed until "PLAY" indicator appears.

Pause

To pause, press PAUSE. To resume playback, press again or press other playback button. Pause ends scan modes and suspends other playback modes.

Track Scan

Press SCA to start Track Scan. Track Number blinks during scanning operation. Unit stops at each track for 10 seconds. After scanning all tracks on disc, unit advances to next disc. Unit continuously scans until user stops scan by pressing SCA, another playback control or SRC. Track Scan deactivates any previously-active MIX or RPT modes.

Disc Scan

Press and hold SCA for more than 2 seconds to start Disc Scan. Disc Numbers blink during scanning operation. Unit stops at first track on each disc for 10 seconds. Unit continuously scans until user stops scan by pressing SCA, another playback control or SRC. Disc Scan deactivates any previously-active MIX or RPT modes.

Changer Reset

In unlikely case of CD changer trouble, reset CD changer by turning unit's power and/or ignition off, and then power on unit. (See TROUBLESHOOTING below.)

Troubleshooting Guide

The following check will assist in the correction of most problems which you may encounter with your unit. Before going through the check list below, refer back to the connection and operating procedures.

General

Trouble	Cause/Solution
No sound.	<ul style="list-style-type: none">Adjust the volume with the + button.With a two-speaker system set the fader control to the center position.

Radio reception

Trouble	Cause/Solution*
Preset stations are not receivable.	<ul style="list-style-type: none">The broadcast is too weak.
Automatic tuning is not possible.	<ul style="list-style-type: none">The broadcast is too weak. → Use manual tuning.
Travel Store feature does not complete storing of six stations.	<ul style="list-style-type: none">Not enough broadcast frequencies are receivable.

* Also make sure that antenna is connected, extended and dry inside.

CD Changer operation

Trouble	Cause/Solution
CD play does not start.	<ul style="list-style-type: none">Dusty or defective disc.The ambient temperature is more than 50°C (120°F).
The disc cannot be loaded or is automatically ejected.	<ul style="list-style-type: none">The disc is inserted with the printed side downwards.
The sound skips due to vibration.	<ul style="list-style-type: none">The changer is installed at an angle of more than 20°.The changer is not installed on the sturdy part of a car.Dusty or defective disc.

Error Displays

Display	Cause	Solution
"CD Err"	A disc problem such as an upside down or dirty disc, or a CD-ROM (computer) disc.	Insert the disc correctly. Clean the disc.
"No Disc"	No magazine or disc in changer	Take out the magazine and insert the discs.

If the above mentioned solutions do not help to improve the situation, consult your nearest Blaupunkt dealer or if in the United States call 1-800-266-2528.



Bosch Group

**German Headquarters:
Blaupunkt-Werke GmbH
Postfach 77 77 77
D-31132 Hildesheim
Germany**

**Robert Bosch Corporation
Sales Group — Blaupunkt Division
2800 South 25th Avenue, Broadview, Illinois 60153
1-800-950-BLAU**

**Robert Bosch, SA., DE, C. V.
Dr. Lucio 270
Cols. Doctores, Mexico 06720**

**Made in Malaysia
Fabrique en Malasie
Hecho en Malasia
Fabricado en Malaysia**

Copyright 1997 by the Robert Bosch Corporation

**No portion of this work may be reproduced in any form without
the written consent of the Robert Bosch Corporation.**