

711-M28 MARINE TRAVELER® TOILET OWNER'S MANUAL

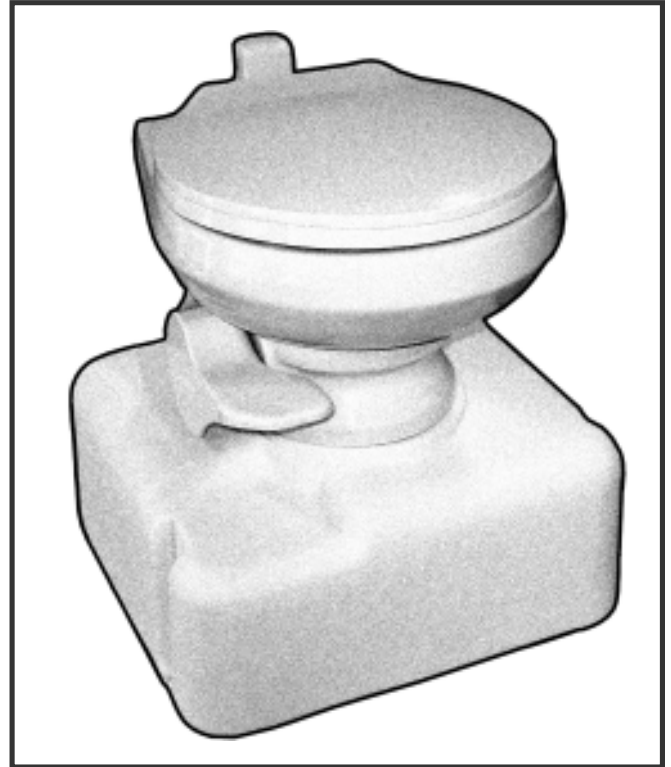

Dometic Corporation
13128 State Rt 226, PO Box 38, Big Prairie, Ohio 44611-0038 U.S.A.
SeaLand Product Hotline 1-800-321-9886
(8:00 a.m. - 5:00 p.m. ET)

TABLE OF CONTENTS

Specifications	2
Recommendations	2
Installation Instructions	2 - 4
Operating Instructions	4
Maintenance	4 - 5
Preparing for Summer Use	5
Model Identification	5
Spare Parts	5
Customer Service	5
Parts List	6
Troubleshooting Guide	7
Warranty	8

SPECIFICATIONS

Product Name: 711-M28 Marine Traveler Toilet

Shipping Information:

Carton Sizes:

Toilet	21" x 18-1/2" x 13-1/2" (533mm x 470mm x 343mm)
Tank	19-1/4" x 17-1/2" x 11-1/2" (489mm x 445mm x 292mm)
Weight	Approx. 49 lbs. (22Kg)

System:

Average water consumption per flush	1 Qt. (.95L)
Minimum water consumption per flush	1 Pt. (.47L)
Holding tank capacity	9.5 Gal. (36L)
Fresh water supply pressure	5-80 PSI
Water inlet size	1/2" NPT
Holding tank discharge fitting	1-1/2" NPT
Vent fitting	5/8" Barb
Unit Weight	41 Lbs. (19Kg)

Dimensions:

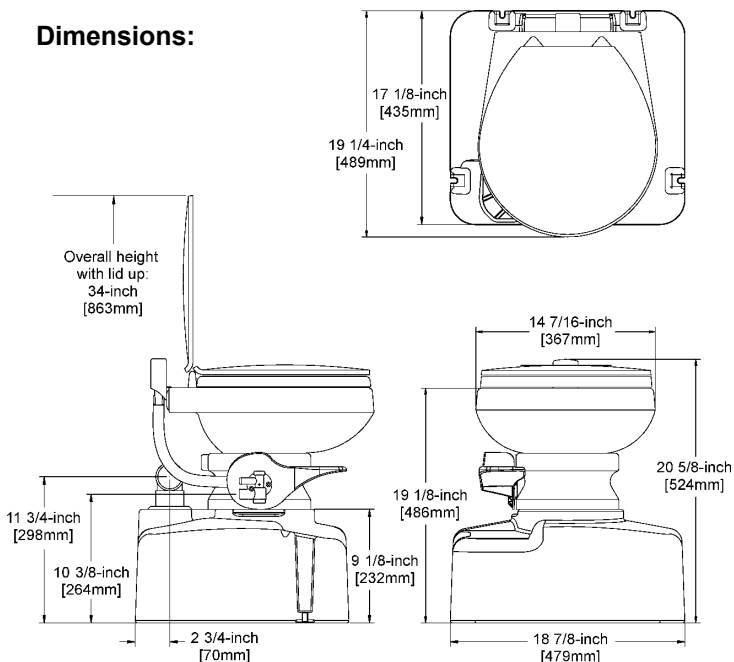

RECOMMENDATIONS

1. Read the "Operating Instructions" section of the manual carefully.
2. Make sure all guests understand the operation of the Traveler toilet.
3. Carry a few spare parts for the maintenance purposes. SeaLand has developed several repair kits that will save you both time and expense should a problem occur. See "Customer Service" section of this manual.
4. Use only SeaLand brand® Tissue and Secure® liquid or SeaLand® brand Holding Tank Deodorants to maintain a trouble-free system.
5. Do not use chlorine or caustic chemicals, such as laundry bleach or drain opening types, in the system. These products damage the seals in toilets.
6. Do not flush foreign objects through the toilet.
7. Do not allow small problems to go unsolved. As soon as a problem is detected, correct it.

INSTALLATION INSTRUCTIONS

Tank:

1. Select position in bathroom where unit can operate properly. Allow room for using the flush lever and clearance for raising the seat and lid.
2. Position the tank 3/4" (19mm) away from the wall. Mark four holes at mounts on tank base. After holes are marked, remove tank, and drill pilot holes. Slide tank back into position. Secure the tank with four #14 x 2" long pan head screws and washers on all tank mounts.

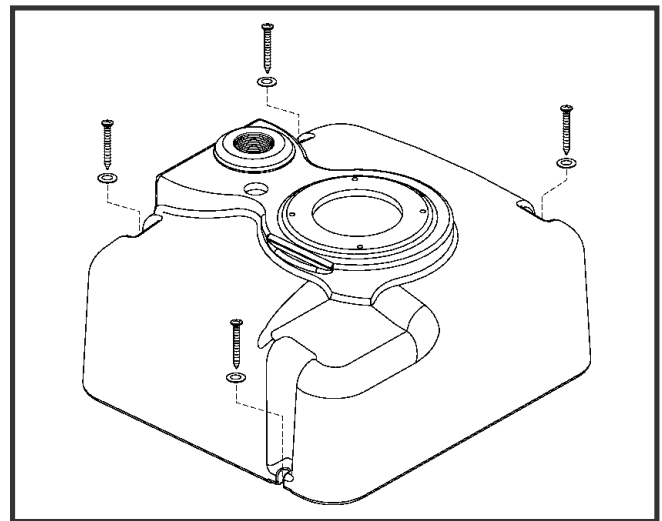

3. Run 5/8" (16mm) I.D. hose to vent fitting and secure with hose clamps.

Install thru-hull vent fitting:

(not supplied with unit – SeaLand part number 346368)

4. Drill hole through the hull, well above water line and directly above Traveler toilet. Hole location is determined by routing and length of hose.

INSTALLATION INSTRUCTIONS (cont'd)

5. Apply waterproof caulk around underside of thru-hull vent fitting.
6. Install thru-hull vent fitting and secure snugly with nut. Wipe off excess caulk with damp cloth.
7. Attach remaining end of vent hose to thru-hull fitting with hose clamp.

Dockside Discharge Fitting: (not supplied by SeaLand)

8. Drill hole in deck directly above Traveler toilet. Hole location is determined by routing space and length of hose.
9. Screw 1-1/2" FPT x 1-1/2" hose barb into bottom of deck fitting.

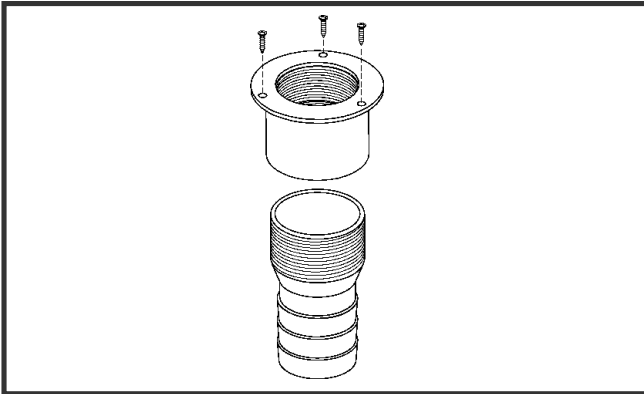

10. Apply waterproof caulk around deck hole and install deck fitting into 2-1/4" (57mm) hole with screws. Wipe off excess caulk with a damp cloth.
11. Install 1-1/2" MPT x HUB adapter into discharge fitting on holding tank. If necessary, PVC cement elbow and hose adapter or hose adapter only into 1-1/2" (38mm) adapter. Secure 1-1/2" (38mm) hose to adapter with hose clamp.

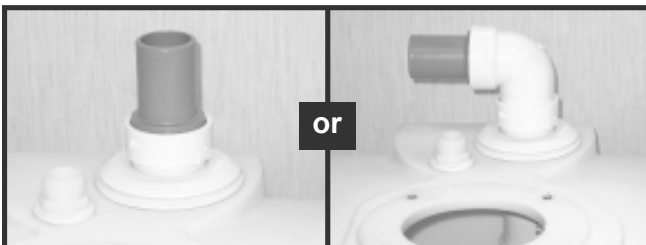

12. Route hose from tank to deck fitting and secure with hose clamp.

Note: The holding tank on the 711-M28 is designed to withstand discharge by a properly operating discharge pump.

Toilet Installation:

13. Push button on back of flush pedal, then pull flush pedal cover away from pedal to expose water valve. Remove plastic pedestal cover from toilet base.

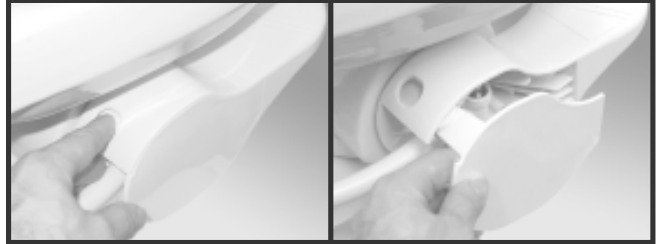

14. Install the (4) 1/4-20 x 1-3/4" long studs in inserts on the tank top.

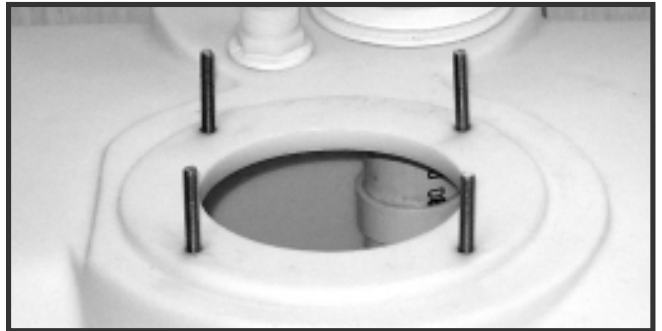

15. Place floor flange seal on studs, aligning the studs with bumps on seat. Note: "THIS SIDE UP" should face upwards.



16. Place toilet on studs and secure with four washers and four nuts.

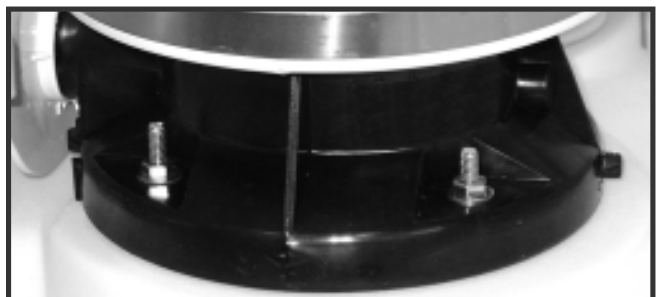

INSTALLATION INSTRUCTIONS (cont'd)

Water line:

17. Locate water valve at rear of flush lever.
18. Attach water supply pipe or hose from water system to inlet fitting on back of water valve.

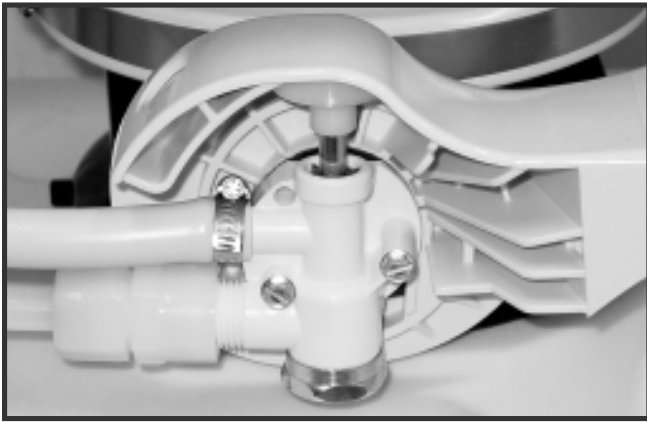

Pedestal cover:

19. Slide back side of pedestal cover around rear of toilet base and snap in groove. Close front half of pedestal cover and snap in groove.

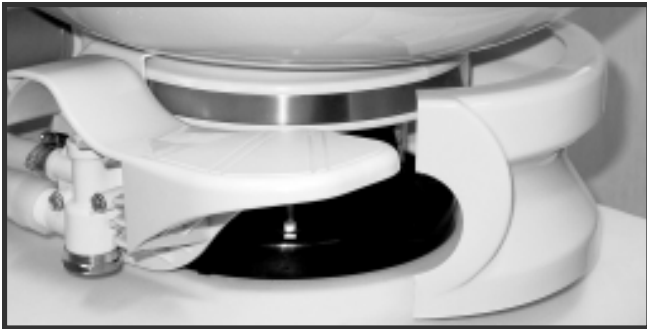

Flush pedal cover:

20. Put flush pedal cover back in place.

Seat and lid:

21. Remove seat and lid from package. Secure to china bowl using instructions from mounting pack.

OPERATING INSTRUCTIONS

To properly use the Traveler® toilet, follow these simple instructions:

1. A good biodegradable tissue such as SeaLand® brand is recommended.
2. To add water to the toilet before using, lift or raise the flush pedal.
3. To flush toilet, push pedal all the way down until sewage leaves the toilet bowl. Water flow pressures vary at different locations and therefore, holding the flush lever down 4-8 seconds may be required. We recommend 2-4 GPM (8-15 Lpm) for proper rim and bowl wash.
4. Release flush pedal by allowing it to snap back, which permits positive sealing around the flush ball.
5. A small amount of water should remain in the bowl.

Note: Holding the flush pedal down longer than necessary results in excessive water usage.

CAUTION: Do not dispose of sanitary napkins or other non-dissolving items in the toilet.

MAINTENANCE

CLEANING

The Traveler toilet should be cleaned regularly for maximum sanitation and operational efficiency.

Clean the toilet bowl with a mild bathroom cleaner, such as SeaLand's Brilliance™ thick liquid toilet bowl cleanser. Do not use chlorine or alcohol-based caustic chemicals such as drain opening types, as they will damage the seals.

If an odor is apparent from the toilet:

1. Clean out system by flushing several gallons of fresh water through with one cup of dry laundry soap.
2. Add odor control deodorant in amount specified for your holding tank capacity after cleaning and every few days during use.

WINTERIZING

At the end of each season, the Traveler toilet should be winterized for storage by either draining or using potable water safe antifreeze in the system.

To drain:

1. Thoroughly flush system with fresh water.
2. Empty holding tank.
3. Shut off water supply to toilet. Remove inlet waterline.
4. Press flush lever until all water is drained from toilet.

MAINTENANCE (cont'd)

To use antifreeze:

1. Thoroughly flush system with fresh water.
2. Empty holding tank.
3. Drain potable water tank.
4. Add freshwater antifreeze and water mixture through toilet and into the waste holding tank. Each installation is different, so amounts may vary. User discretion is required to assure adequate protection.
5. Empty holding tank.

Note: Use nontoxic antifreeze designated for potable water systems (see boat owner's manual).

CAUTION: Never use automotive-type antifreeze in freshwater systems.

PREPARING FOR SUMMER USE

To prepare the Traveler toilet for summer use, turn on water supply and check system for leaks. Flush toilet, check for leaks and repair as necessary. Your Traveler toilet is now ready for use.

MODEL IDENTIFICATION

The model identification label is located on the inside of the flush pedal cover.

DOMETIC CORPORATION

P.O. BOX 38, 13128 STATE RT 226 (800) 321-9886
BIG PRAIRIE, OH 44611 USA

MODEL NO. **000**

SERIAL NUMBER

000000

SPARE PARTS

Your 711-M28 Traveler toilet is designed for years of dependable trouble free service. However, during the life of the product certain parts may require replacement. The following is a list of parts kits which may be required for maintenance purposes.

Part Number	Description
318162	Ball, Shaft & Cartridge Kit
316140	Seal Kit
314349	Water Valve Kit
316906	Vacuum Breaker Kit

CUSTOMER SERVICE

SeaLand has a strong, worldwide network to assist in servicing and maintaining your Traveler toilet if parts or service are required. Before calling, please have the following information available. Your cooperation in having this information ready is appreciated and allows our Customer Service Department to better meet your needs. When you call, we will direct you to the nearest parts distributor.

1. Toilet Model Number
2. Serial Number
3. Part Number, Description and Quantity (See Parts List.)

When you have gathered all the required information, call us at one of the following telephone numbers from 8:00 a.m. to 5:00 p.m. (Eastern Time) Monday through Friday, or email us.

**Telephone: 1-800-321-9886 USA and Canada
330-496-3211 International**

**Fax: 330-496-3097 USA and Canada
330-496-3220 International**

Email: sealand@dometicus.com

MASTER SANITATION DISTRIBUTORS – NORTH AMERICA

U.S.A. – North Central
(IL, IN, KY, MI, OH)

Midwest Marine Supply
24300 Jefferson Ave.
St. Clair Shores, MI 48080
Tel: 810-778-8950
800-860-1540

E-mail: mikekennedy@voyager.net

U.S.A. – Northeast
(CT, DE, DC, MA, MD, ME, NH, NJ, NY, PA,
RI, VA, VT, WV)

Northeast Marine Sanitation
69 Florida Street
Farmingdale, NY 11735
Tel: 631-752-7606
800-352-4323

E-mail: northeast
@northeast sanitation.com

U.S.A. – Northwest
(AK, ID, MT, OR, WA, WY)

Marine Sanitation, Inc.
1900 N. Northlake Way, Suite 121
Seattle, WA 98103
Tel: 206-633-1110
800-624-9111

E-mail: marinesan@minespring.com

U.S.A. – South Central
(AR, KS, LA, MO, MS, NM, OK, TX)

AER Supply
P.O. Box 349
2301 Nasa Road #1
Seabrook, TX 77586
Tel: 281-474-3276
800-767-7606

E-mail: rsmiller@aersupply.com

U.S.A. – Southeast
(AL, FL, GA, NC, PR, SC, TN, VI)

Environmental Marine
111 S.W. 23rd Street, Suite A
Fort Lauderdale, FL 33315
Tel: 954-522-2626
800-522-2656

E-mail: info@environmentalmarine.com

U.S.A. – Southwest
(AZ, CO, NV, UT, CA-south)

Ardemco Marine Specialties
778 West 17th Street
Costa Mesa, CA 92627
Tel: 949-722-7672
800-253-0115

E-mail: ardemco@earthlink.net

U.S.A. – Upper Midwest
(IA, MN, NE, ND, WI, SD)

PowerHouse Marine
518 Logan
La Crosse, WI 54603
Tel: 608-784-9580
888-752-4539

E-mail: tuckski@rconnect.com

U.S.A. – Northern California

Fox Marine
2250 Zanker Road, Unit D
San Jose, CA 95131
Tel: 408-451-9055
800-826-2873

E-mail: foxmarco@pacbell.net

Canada – East

Eastern Marine Systems, Inc.
12-A Leslie Street
Toronto, Ontario M4M 3H7
Tel: 416-465-1668
888-764-1111

E-mail: info@eastmar.com

Canada – West

Western Marine Company
1494 Powell Street
Vancouver, BC V5L 5B5
Tel: 604-253-7721
800-663-0600

E-mail: sales@westernmarine.com

TROUBLESHOOTING GUIDE

Problem	Possible Cause	Service Instructions
1. Water will not stay in bowl.	<ul style="list-style-type: none"> a. Loose clamp. b. Improper seal around flush ball due to dirt or debris on underside of Teflon ball seal. c. Worn or damaged seal. d. Worn or damaged flush ball. 	<ul style="list-style-type: none"> a. Tighten clamp ring adjusting nut. b. Inspect flush ball and underside of Teflon® seal for foreign objects. c. Replace seal. d. Replace flush ball.
2. Plastic flush ball will not close completely.	<ul style="list-style-type: none"> a. Clamp ring is overtightened, causing too much tension on seal and flush ball. b. Weak or defective spring cartridge. 	<ul style="list-style-type: none"> a. Loosen clamp ring. b. Check spring tension by letting up on flush lever suddenly. If lever does not snap back, replace spring cartridge.
3. Water does not shut off in toilet (toilet overflows).	<ul style="list-style-type: none"> a. Dirt lodged in water valve seal. b. Cam strap is bent down, holding water valve open. c. Worn or defective water valve. d. Worn or defective spring cartridge. 	<ul style="list-style-type: none"> a. Disassemble and clean water valve. b. Bend front of cam strap up about 1/16" (1.6mm). c. Replace valve assembly. d. Replace spring cartridge.
4. Water does not enter toilet bowl properly.	<ul style="list-style-type: none"> a. Low water pressure. b. Water valve clogged. 	<ul style="list-style-type: none"> a. Check incoming water pressure. b. Remove and clean filter screen located on inlet of water valve.
5. Water leaking from water valve.	<ul style="list-style-type: none"> a. Loose connection. b. Worn or defective water valve. c. Water line connection not seated properly. d. Stripped threads. e. Seal worn or missing. f. Valve body cracked. 	<ul style="list-style-type: none"> a. Tighten bottom cap, inlet fitting and outlet hose clamp. b. Replace water valve. c. Correct. d. Replace water valve. e. Replace water valve. f. Replace water valve.
6. Water leaking from rear of toilet bowl.	<ul style="list-style-type: none"> a. Loose hose connection. b. Loose vacuum breaker. c. Worn or defective vacuum breaker. d. Cracked or defective toilet bowl. 	<ul style="list-style-type: none"> a. Tighten hose connections. b. Tighten vacuum breaker-to-bowl connection. c. Replace vacuum breaker assembly. d. Replace toilet bowl.

PARTS LIST

711-M28 TRAVELER®		ITEM	PART NO.	DESCRIPTION
	1	340591	Seat Assembly, Bone	
	2	310781	China Bowl, Bone	
	3	310048	Half Clamp Kit, Bone	
	4	316140	Teflon® & Rubber Seal Kit	
	5	310891	Base Kit, Bone	
	6	310109	Pedestal Cover Kit, Bone	
	7	310681	Flush Ball, Shaft & Cartridge Kit (includes item 10)	
	8	341549	Floor Flange Seal	
	9	314349	Water Valve Kit	
	10	310683	Spring Cartridge Kit	
	11	340177	Water Supply Hose	
	12	316906	Vacuum Breaker Kit	
	13	310782	Vacuum Breaker Cover Kit	
	14	341161	90° Ell, 1½" Hub	
	15	341425	Adapter, 1½" Hub x MPT	
	16	310532	Diptube Assembly	
	17	310534	Toilet Mounting Kit	
	18	310085	Tank Kit, Bone (includes items 16 & 21)	
	19	342798	Mounting Spindle (optional)	
	20	342704	Screw, #14 x 2" Pan Phil. Head SS	
	21	314362	Vent Fitting Kit	
	22	341513	Hose Adapter Fitting	
	23	310786	Flush Pedal, Bone (includes item 10)	

MANUFACTURER'S ONE-YEAR LIMITED WARRANTY

SeaLand warrants, to the original purchaser only, that this product, if used for personal, family or household purposes, is free from defects in material and workmanship for a period of one year from the date of purchase.

If this SeaLand product is placed in commercial or business use, it will be warranted, to the original purchaser only, to be free of defects in material and workmanship for a period of ninety (90) days from the date of purchase.

SeaLand reserves the right to replace or repair any part of this product that proves, upon inspection by SeaLand, to be defective in material or workmanship. All labor and transportation costs or charges incidental to warranty service are to be borne by the purchaser-user.

EXCLUSIONS

IN NO EVENT SHALL **SEALAND** BE LIABLE FOR INCIDENTAL OR CONSEQUENTIAL DAMAGES, FOR DAMAGES RESULTING FROM IMPROPER INSTALLATION, OR FOR DAMAGES CAUSED BY NEGLIGENCE, ABUSE, ALTERATION OR USE OF UNAUTHORIZED COMPONENTS. ALL IMPLIED WARRANTIES, INCLUDING ANY IMPLIED WARRANTY OF MERCHANTABILITY OR FITNESS FOR ANY PARTICULAR PURPOSE, ARE LIMITED TO A PERIOD OF ONE YEAR FROM DATE OF PURCHASE.

IMPLIED WARRANTIES

No person is authorized to change, add to, or create any warranty or obligation other than that set forth herein.

Implied warranties, including those of merchantability and fitness for a particular purpose, are limited to one (1) year from the date of purchase for products used for personal, family or household purposes, and ninety (90) days from the date of purchase for products placed in commercial or business use.

OTHER RIGHTS

Some states do not allow limitations on the duration of an implied warranty and some states do not allow exclusions or limitations regarding incidental or consequential damages; so, the above limitations may not apply to you. This warranty gives you specific legal rights, and you may have other rights which vary from state to state.

To obtain warranty service, first contact your local dealer from whom you purchased this product.



The first choice in marine and RV sanitation.

Dometic Corporation
13128 State Rt 226, P.O. Box 38, Big Prairie, OH 44611-0038 USA
SeaLand Product Customer Service
1-800-321-9886
330-496-3211 (8:00 a.m.-5:00 p.m. ET)
Fax: 330-496-3097