

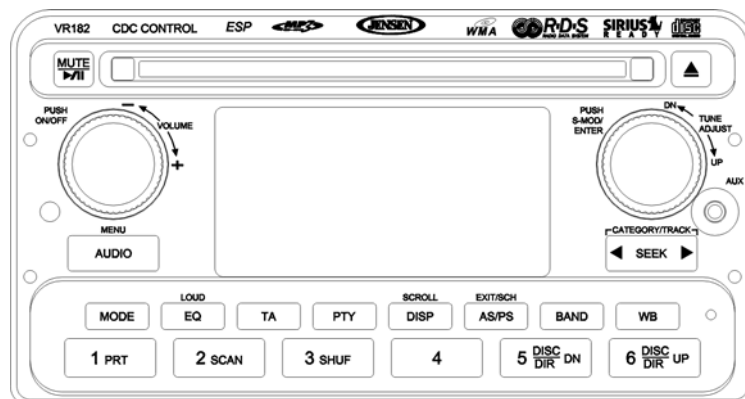

VR182

MOBILE AUDIO SYSTEM

Installation and Operation Manual





SAFETY INFORMATION

When Driving

Keep the volume level low enough to be aware of the road and traffic conditions.

Protect from Water

Do not expose the product to water, as this can cause electrical shorts, fire or other damage.

Protect from High Temperatures

Exposure to direct sunlight for an extended period of time can produce very high temperatures inside your vehicle. Give the interior a chance to cool down before starting playback.

Do not mount radio within close proximity of engine compartment.

Use the Proper Power Supply

This product is designed to operate with a 12 volt DC negative ground battery system.

Protect the Disc Mechanism

Avoid inserting any foreign objects into the disc slot. Misuse may cause malfunction or permanent damage due to the precise mechanism of this unit.

CAUTION:

THIS MOBILE CD PLAYER IS A CLASS I LASER PRODUCT. THIS UNIT USES A VISIBLE/ INVISIBLE LASER BEAM WHICH COULD CAUSE HAZARDOUS RADIATION IF EXPOSED DIRECTLY. BE SURE TO OPERATE THE MOBILE CD PLAYER AS INSTRUCTED.

USE OF CONTROLS OR ADJUSTMENTS OR PERFORMANCE OR PROCEDURES OTHER THAN THOSE SPECIFIED HEREIN MAY RESULT IN HAZARDOUS RADIATION EXPOSURE.

DO NOT OPEN COVERS AND DO NOT REPAIR BY YOURSELF. PLEASE REFER SERVICING TO A QUALIFIED TECHNICIAN.

WARNING:

- TO REDUCE THE RISK OF FIRE OR ELECTRIC SHOCK, DO NOT EXPOSE THIS EQUIPMENT TO WATER.
- TO REDUCE THE RISK OF FIRE OR ELECTRIC SHOCK AND INTERFERENCE, USE ONLY THE RECOMMENDED ACCESSORIES.
- THIS DEVICE IS INTENDED FOR CONTINUOUS OPERATION.

DISC NOTES

Depending on the recording status, conditions of the disc, and the equipment used for recording, some CD-Rs/CD-RWs may not play on this unit. For more reliable playback, please adhere to the following recommendations:

- Use CD-RWs with speed 1x to 4x and write with speed 1x to 2x.
- Use CD-Rs with speed 1x to 8x and write with speed 1x to 2x.
- Do not play a CD-RW which has been written more than 5 times.

Compatible Disc Types

Table 1: General Disc Information

Disc Type	Logo	Diameter/ Playable Sides	Playback Time
Audio CD		12 cm single side	74 minutes

NOTE: CD-R and CD-RW discs will not play unless the recording session is closed and the CD is finalized.

Disc Maintenance

- A dirty or defective disc may cause sound dropouts while playing. Before playing, wipe the disc using a clean cloth, working from the center hole towards the outside edge. Never use benzene, thinners, cleaning fluids, anti-static liquids or any other solvent.

<p>Insert label side up.</p>	<p>Do not bend.</p>	<p>Never touch the under side of the disc.</p>	<p>Wipe clean from the center to the edge.</p>
-------------------------------------	----------------------------	---	---

- Be sure to use only round CDs for this unit and do not use any special shape CDs. Use of special shape CDs may cause the unit to malfunction.
- Do not stick paper or tape on the disc. Do not use CDs with labels or stickers attached or that have sticky residue from removed stickers.
- Do not expose discs to direct sunlight or heat sources such as hot air-ducts, or leave them in a vehicle parked in direct sunlight where there can be a considerable rise in temperature inside the vehicle.

NOTE: A disc may become scratched (although not enough to make it unusable) depending on how you handle it and other conditions in the usage environment. These scratches are not an indication of a problem with the player.

INSTALLATION

Before You Begin

- Disconnect Battery**
Before you begin, always disconnect the battery negative terminal.
- Remove Transport Screws and discard.**

Important Notes

- Before final installation, test the wiring connections to make sure the unit is connected properly and the system works.
- Use only the parts included with the unit to ensure proper installation. The use of unauthorized parts can cause malfunctions.
- Consult with your nearest dealer if installation requires the drilling of holes or other modifications to your vehicle.
- Install the unit where it does not interfere with driving and cannot injure passengers if there is a sudden or emergency stop.
- If the installation angle exceeds 30° from horizontal, the unit might not give optimum performance.
- Avoid installing the unit where it will be subject to high temperatures from direct sunlight, hot air, or from a heater, or where it would be subject to excessive dust, dirt or vibration.

DIN Front Mount

This unit can be installed in a dashboard with an opening of the following dimensions:

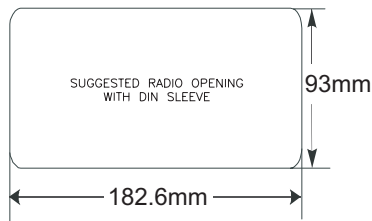

1. Slide the mounting sleeve off of the chassis if it has not already been removed. If it is locked into position, use the removal keys (supplied) to disengage it. Insert the keys through the holes in the front panel as far as they will go, and then slide the sleeve off the back of the unit.

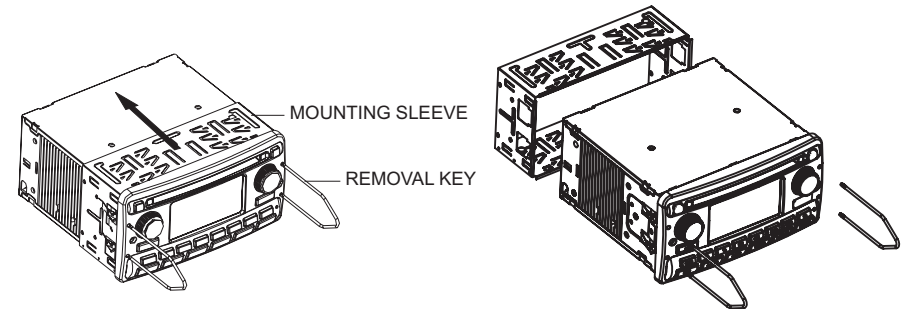

2. Check the dashboard opening size by sliding the mounting sleeve into it. If the opening is not large enough, carefully cut or file as necessary until the sleeve easily slides into the opening. Do not force the sleeve into the opening or cause it to bend or bow. Check that there will be sufficient space behind the dashboard for the radio chassis.
3. Locate the series of bend tabs along the top, bottom and sides of the mounting sleeve. With the sleeve fully inserted into the dashboard opening, bend as many of the tabs outward as necessary to firmly secure the sleeve to the dashboard.

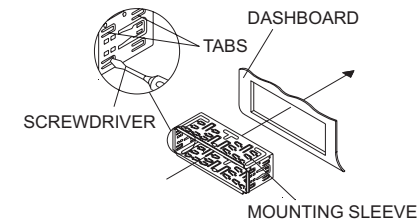

4. Place the radio in front of the dashboard opening so the wiring can be brought through the mounting sleeve.
5. Follow the wiring diagram carefully and make certain all connections are secure and insulated with crimp connectors or electrical tape to ensure proper operation.
6. After completing the wiring connections, reconnect battery and turn the unit on to confirm operation (vehicle ignition switch must be on). If the unit does not operate, recheck all wiring until the problem is corrected. Once proper operation is achieved, turn the ignition switch off and proceed with final mounting of the chassis.
7. Carefully slide the radio into the mounting sleeve making sure it is right-side-up until it is fully seated and the spring clips lock it into place.
8. Test radio operation by referring to the operating instructions for the unit.

Ford Vehicle Mount

1. Remove the mounting sleeve (see step 1 of "DIN Front Mount" on page 4). The mounting sleeve is not used in this application.
2. Use the supplied mounting screw and the rear installation bracket to secure the unit in place.

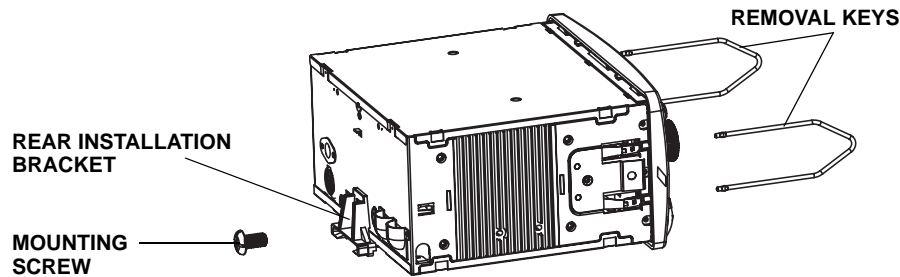

3. Place the radio in front of the dashboard opening so the wiring can be brought through the mounting sleeve.
4. Follow the wiring diagram carefully and make certain all connections are secure and insulated with crimp connectors or electrical tape to ensure proper operation.
5. After completing the wiring connections, reconnect battery and turn the unit on to confirm operation (vehicle ignition switch must be on). If the unit does not operate, recheck all wiring until the problem is corrected. Once proper operation is achieved, turn the ignition switch off.
6. Carefully slide the radio onto the guide rail inside the vehicle dash until it is fully seated and the spring clips lock into place.
7. Test radio operation by referring to the operation section for the unit.

Removing the Unit

To remove the radio after installation:

1. Make sure the ignition is turned off, and then disconnect the cable from the vehicle's battery negative (-) terminal.
2. Insert the removal keys straight into the holes on the front of the unit, as far as they will go.
3. Pull the radio straight out.

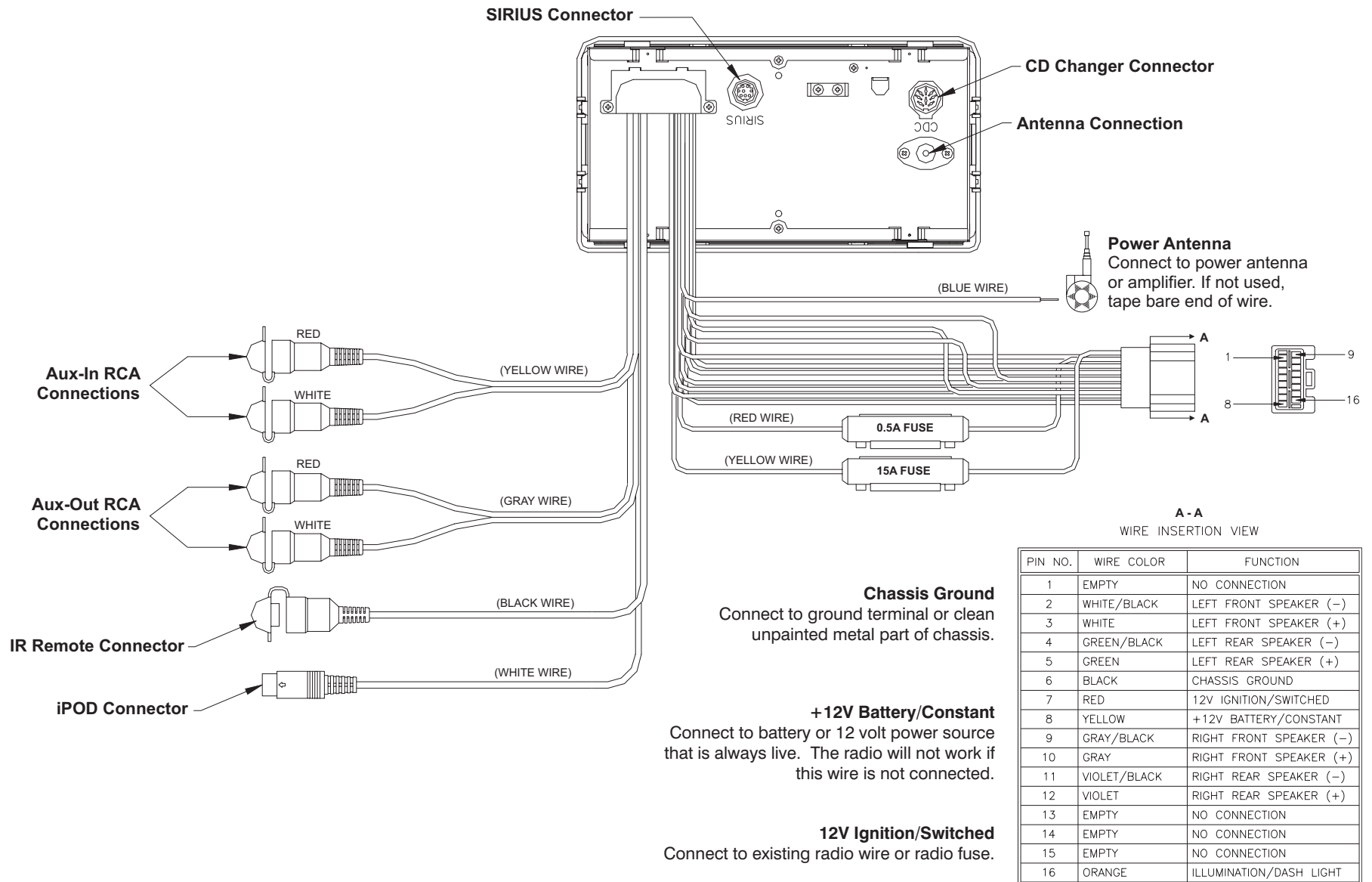
WIRING

BASIC OPERATION

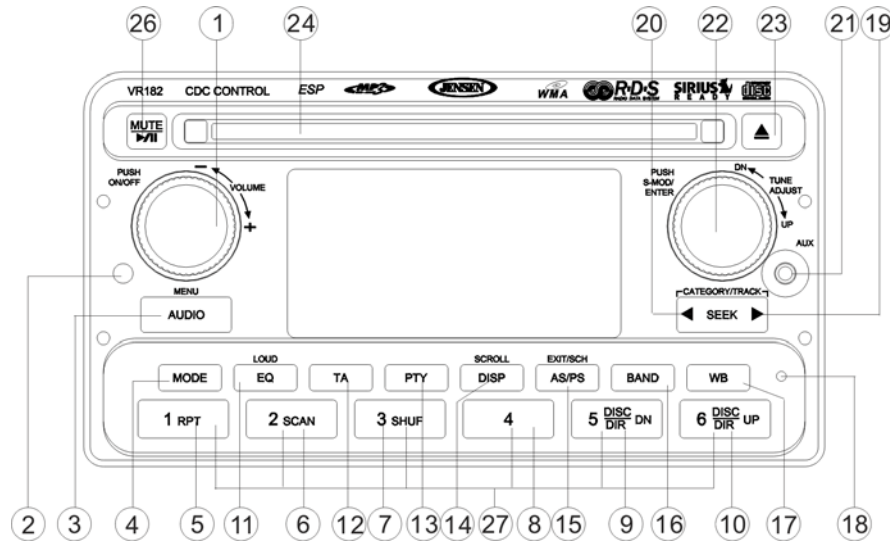

Power On/Off

Press any button (except the eject ▲ button (23)) to turn the unit ON. Press the **VOLUME/ON/OFF** button (1) to turn the unit OFF.

Volume Control

To increase the volume, rotate the volume control (1) clockwise.

To decrease the volume, rotate the volume control counter clockwise.

Mute

Press the **MUTE** button (26) on the control panel to mute the audio output. "Mute" will appear on the LCD display. Press **MUTE** again to restore the audio output to the previous level.

Mode

Press the **MODE** button (4) on the control panel to select a different mode of operation, as indicated on the display panel. Available modes include TUNER, CD, SIRIUS, IPOD, CDC and AUX IN (optional Auxiliary Input).

NOTE: CDC, IPOD, or SIRIUS mode will be skipped if the module is not installed.

Adjusting the Clock (DISP)

The current time is displayed in the lower right hand corner of the LCD display.

To adjust the clock:

1. Press the **DISP** button (14) until the hour flashes on the LCD.

2. Rotate the **VOLUME** control (1) within 5 seconds to adjust the hours.
3. Press the **DISP** button again and the minutes will flash.
4. Rotate the **VOLUME** control within 5 seconds to adjust the minutes.
5. Press **DISP** again to exit time set mode. After 5 seconds, time set mode will exit automatically.

NOTE: If the time mode is set to "12 HOUR" in the setup menu, continue turning the VOLUME control to change between AM (A) and PM (P).

NOTE: If "P-CLOCK ON" is selected in the setup menu, the clock will be displayed in the center of the LCD in large characters when the unit is turned off while the ACC is on.

Reset

Use a ball point pin or thin metal object to press the **RESET** button (18). The unit will return to the factory default settings. The reset button should be activated for the following reasons:

- initial installation of the unit when all wiring is completed
- function buttons do not operate
- error symbol on the display

To recover factory default settings, *press and hold* the **MODE** button (4) for more than 3 seconds. The LCD will display "EEP-INIT" and all settings will return to the original factory values.

Audio Menu

Press the **AUDIO/MENU** button (3) on the control panel to access the Audio Menu. You can navigate through the Audio Menu items by pressing the **AUDIO/MENU** button repeatedly. Once the desired menu item appears on the display, adjust that option by turning the **VOLUME** control (1) within 5 seconds. The unit will automatically exit the Audio Menu after five seconds of inactivity. The following menu items can be adjusted.

Bass Level

Use the volume control to adjust the Bass level range from "-6" to "+6".

Treble Level

Use the volume control to adjust the Treble level range from "-6" to "+6".

Balance

Use the volume control to adjust the Balance between the left and right speakers from "12L" (full left) to "12R" (full right).

Fader

Use the volume control to adjust the Fader between the rear and front speakers from "12R" (full rear) to "12F" (full front).

Volume Level

Use the volume control to adjust the Volume level from 0 to 46.

System Menu

1. Press and hold the **MENU/AUDIO** button (3) for more than 3 seconds to enter the system menu.
2. Rotate the **VOLUME** control (1) to highlight the desired item.
3. Press the **VOLUME** button (1) to select the highlighted item.
4. Rotate the **VOLUME** control to select a value.
5. Press the **VOLUME** button to return to menu selection mode.

The following feature functions can be adjusted:

- **BEEP (ON/OFF)**: Turn the audible beep ON/OFF (heard when functions/buttons are selected).
- **P-VOLUME (00 – 46)**: Select an automatic turn-on volume.
- **AREA (EURO/USA)**
- **P-CLOCK (ON/OFF)**: Choose “ON” to display the clock in large format when the radio is turned off while ACC is on.
- **CLOCK (12/24 HOUR)**
- **CONTRAST (-6 – +6)**
- **BRIGHTNESS (0 – 7)**
- **AUTO IPOD (ON/OFF)**: Choose “ON” to automatically switch to iPod mode when an iPod is connected.

Default values: BEEP ON, P-VOLUME 12, USA, CLOCK ON, 12 HOUR, CONTRAST 0, BRIGHTNESS 4, AUTO IPOD ON.

Equalizer

Press the **EQ/LOUD** button (11) to turn the equalization function on/off.

Auxiliary Input

To access an auxiliary device:

1. Connect the portable audio player to the AUX in on the front panel (21) or to the AUX IN cables on the back of the radio.
2. Press the **MODE** button to select Aux In mode.
3. Press **MODE** again to cancel Aux In mode and return to the previous mode.

NOTE: The front AUX input overrides the rear Auxiliary Input.

Scroll

When in Sirius Satellite Radio or iPod mode, press the **SCROLL** button (14) to view the entire program information.

Remote Sensor

Point the remote control handset (sold separately) at the remote sensor IR (2) and press the function keys on the handset to control the system.

TUNER OPERATION

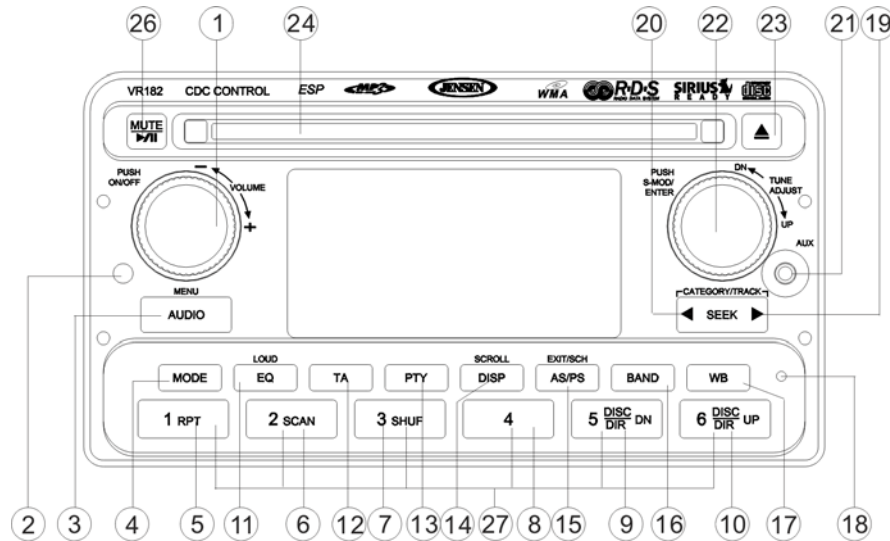

Select a Band

Press the **BAND** button (16) on the control panel to change between two FM bands and one AM band. In Sirius Satellite Radio, WB, CD, CDC, AUX IN or IPOD mode, press the **BAND** button to automatically switch to radio mode.

Tuning

Rotate the **TUNE ADJUST** knob (22) clockwise or counter-clockwise to tune up or down in one step increments. Press the **SEEK >** (19) or **SEEK <** button (20) to seek the next strong station. *Press and hold a **SEEK** button (19/20) to seek the stations up/down step by step.*

Preset Stations

Six numbered preset buttons store and recall stations for each band (FM1, FM2, AM).

Store a Station

Tune radio to desired station. *Press and hold* a preset button (27) for three seconds. A beep tone will confirm the stored station and the preset number will appear in the display.

Recall a Station

Select a band (if needed). Press a preset button (27) to select the corresponding stored station.

Automatic Store / Preset Scan (AS/PS)

Automatic Store

Select a band (if needed). *Press and hold* the **AS/PS** (15) button for more than three seconds to automatically select six strong stations and store them in the current band. New stations

replace any stations already stored in that band. After stations have been stored, the radio will enter Preset Scan and preview each stored station.

Preset Scan

Select a band (if needed). Press **AS/PS** (15) to scan stations stored in the current band. The unit will pause for ten seconds at each preset station. Press **AS/PS** again to stop scanning when the desired station is reached.

Weather Band Selection

In any mode, press the **WB** button (17) to access the weather band (NOAA seven frequency broadcast). In weather band mode, the tuner will automatically seek the active weather band automatically and stop.

Rotate the **TUNE ADJUST** knob (22) clockwise or counter-clockwise to choose a channel from CH1 – CH7. You can also press the six preset buttons (27) to select CH1 – CH6 directly.

Press the **SEEK </>** buttons (20/19) to seek the stations down/up.

Press the **BAND** (16) or **MODE** (4) button to exit weather band mode.

NOTE: The weather band channel frequency is fixed in preset memory and cannot be changed.

RDBS Operation

While in FM Radio mode, press the **TA** button (12) to start search of a Traffic Announcement in your area. If no TA information is being broadcast, the radio will display “NO TA” and return to the previously tuned station.

In any mode, press the **TA** button to access Traffic Announcement mode. If a TA is being broadcast, playback of the current mode will be interrupted and the radio will switch to the FM station issuing the TA. Press the **TA** button again to exit TA mode.

In FM radio mode, press the **PTY** button (13) to list the following search options: ANY / News / Information / Sports / Talk / Rock / Classic Rock / Adult Hits / Soft Rock / Top 40 / Country / Oldies / Soft / Nostalgia / Jazz / Classical / Rhythm and Blues / Soft R&B / Language / Religious Music / Religious Talk / Personality / Public / College / Weather / Emergency Test / Emergency.

Use the **TUNE ADJUST** knob (22) to select an item from the list, then press **SEEK </>** (20/19) to search the corresponding program. “PTY SEARCH” will be displayed in the upper right corner of the LCD. If a corresponding program is found, the unit will play the program. If there is no corresponding program, “PTY NOT FOUND” will be displayed on the LCD.

Stereo (ST)

The unit will automatically pick up an FM stereo signal, when available. When in stereo mode, the “ST” icon appears in the display. When no stereo signal is available, the unit will automatically revert to mono operation, and no icon will be displayed.

CD/MP3/WMA OPERATION

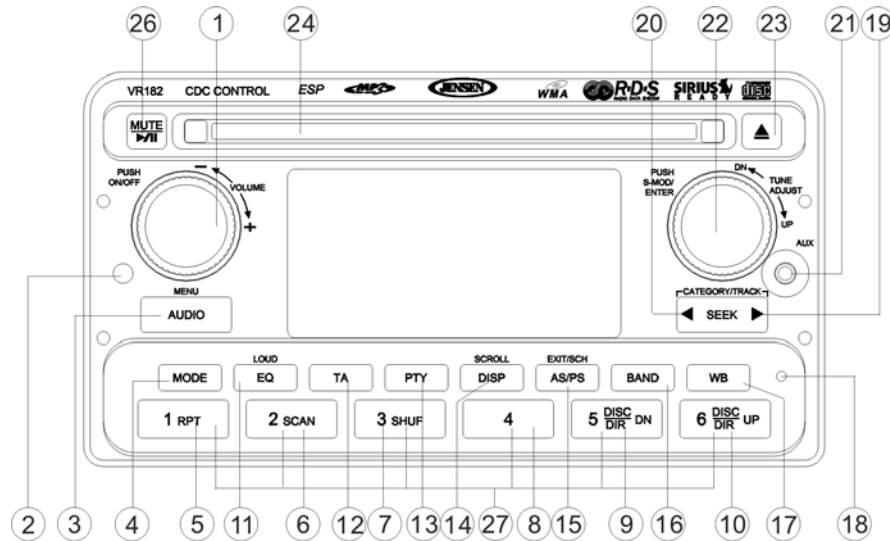

Inserting and Ejecting a Disc

Insert a disc, label-side up, into the disc slot (24) with the unit turned on. The unit will automatically draw the disc in and play the first track on the disc.

Press the eject ▲ button (23) to stop disc play and eject the disc. The unit does not have to be turned on to eject the disc.

Controlling Disc Playback

Selecting Tracks

Press the **SEEK >** (19) or **SEEK <** button (20) to advance to the next track on the CD. The selected track number will appear on the display. *Press and hold* the **SEEK >** (19) or **SEEK <** button (20) to fast forward or fast reverse through the disc. CD play starts when the button is released.

For an MP3/WMA disc, press the **DISC/DIR UP** or **DN** button (10/9) to skip to the following/previous folder.

Play/Pause Disc Playback

Press the **>||** button (26) to suspend disc play. Press the **>||** button again to resume disc Play.

Previewing Tracks

Press the **SCAN** button (6) on the control panel to play the first 10 seconds of each track sequentially. Press **SCAN** again to stop Intro Scan and resume normal play at the current track.

Repeat Play

Press the **RPT** button (5) during disc play to repeat play the current track. Press **RPT** again to stop repeat play.

Random Play

Press the **SHUF** button (7) on the control panel during disc play to play all tracks on a CD in random, shuffled order. "SHUFFLE" will display in the upper right corner. Press **SHUF** again to stop random play.

Selecting MP3/WMA Tracks

The **AS/PS** button (15) functions as the Digital Audio Mode selection button during MP3/WMA operation.

Direct Track Search

1. Press the **AS/PS** button (15) once to search for a track name directly. The current track number will be displayed: "DIRECT 002".
2. Rotate the **VOLUME** control (1) to change the track number.
3. Press the **ENTER** button (22) to search the track.

Directory/File Name Search

1. Press the **AS/PS** (15) button two times to search for a Directory or File Name.
2. Use the **VOLUME** control (1) to input numbers 0 – 9 and characters A – Z.
3. Press the **AUDIO** button (3) to confirm entry of each character.
4. Press the **ENTER** button (22) to start the title search. The unit will search files and directories containing the specified characters.

SIRIUS RADIO OPERATION

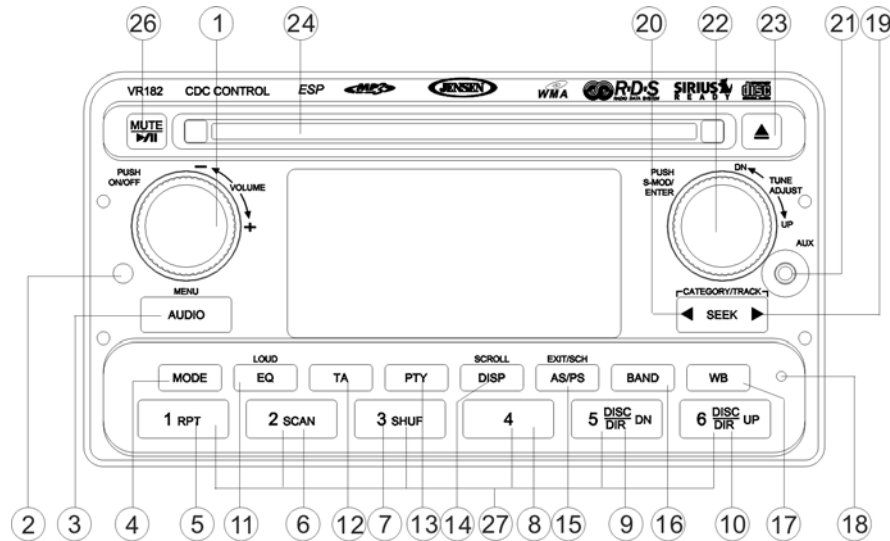

Switching to SIRIUS Mode

Press the **MODE** button (4) to change the mode to Sirius Satellite Radio mode.

Activating Sirius Satellite Radio

In Sirius mode, *press and hold* the **S-MOD** button (22) to select DIRECT mode. The LCD will display "DIRECT ___" upon entry. Use the **TUNE ADJUST UP/DN** knob (22) to select "0" and then press the **ENTER** button (22) to input the number. Continue for remaining digits. Enter "000" to display the 12 digit Sirius ID.

Selecting a Band

In Sirius mode, press the **BAND** button (16) to access the Sirius user-preset channel groups in the following order: SIR1, SIR2, SIR3.

Tuning a Channel

Rotate the **TUNE ADJUST UP/DN** knob (22) clockwise to tune up or counter-clockwise to tune down the available Sirius channels. The channel information display can be changed to emphasize either Artist or Song Title by pressing the **DISP** button (14). *Press and hold* the **DISP** button to scroll.

Selecting a Category

Press the **CATEGORY </>** buttons (20/19) to view available categories. Each category title and associated channels will be displayed in increments. While in the category mode, the individual channels within a category may be accessed by rotating the **TUNE ADJUST UP/DN** knob (22). Once a highlighted channel has been selected, press the **ENTER** button (22) to

tune to that channel. While viewing a category list, press the **DISP** button to change display information between Channel Name, Artist, or Song Title.

Storing Preset Channels

The preset buttons (27) can be used to store 6 channels per band (SIR1, SIR2 and SIR3), allowing convenient access to your favorite channels.

Programming Channels

1. Select the channel you want to store in memory.
2. *Press and hold* a preset button (27) until the corresponding preset button number appears.
3. Repeat steps 1 and 2 to program additional channels.

Recalling a Preset Channel

Press one of the six preset buttons (27) within a selected band to tune a preset channel directly.

Channel Preset Scan

Press the **AS/PS** button (15) to preview each stored preset channel in SIR1, SIR2 and SIR3 for 10 seconds.

Press the **AS/PS** button again to stop scanning and play the current channel.

Direct Tune Mode

1. *Press and hold* the **S-MOD** button (22) to switch to Direct Tune/Skip Channel mode. After accessing Direct mode, "DIRECT ___" appears on the display.
2. Use the **TUNE ADJUST UP/DN** knob (22) to select a number for the hundreds digit position.
3. Press the **ENTER** button (22) to confirm entry of the hundreds digit. The tens digit will flash on/off.
4. Use the **TUNE ADJUST UP/DN** knob to select a number for the tens digit position.
5. Press the **ENTER** button again to confirm entry of the tens digit. The ones digit will flash on/off.
6. Use the **TUNE ADJUST UP/DN** knob to select a number for the ones digit position.
7. Press the **ENTER** button to tune to the selected channel.

Skip Channel Mode

1. *Press and hold* the **S-MOD** button (22) to switch to Direct Tune/Skip Channel mode.
2. While the display is showing "DIRECT ___", press the **S-MOD** button to access Skip Channel mode.
3. Use the **TUNE ADJUST UP/DN** knob (22) to select the channel to be skipped.
4. *Press and hold* the **ENTER** button (22) to skip or release the current channel. (If the channel was previously skipped, the "SKIP" icon will be displayed.)
5. Press the **S-MOD** button (22) to return to normal mode. The unit will automatically return to normal mode after several seconds of inactivity.

IPOD OPERATION

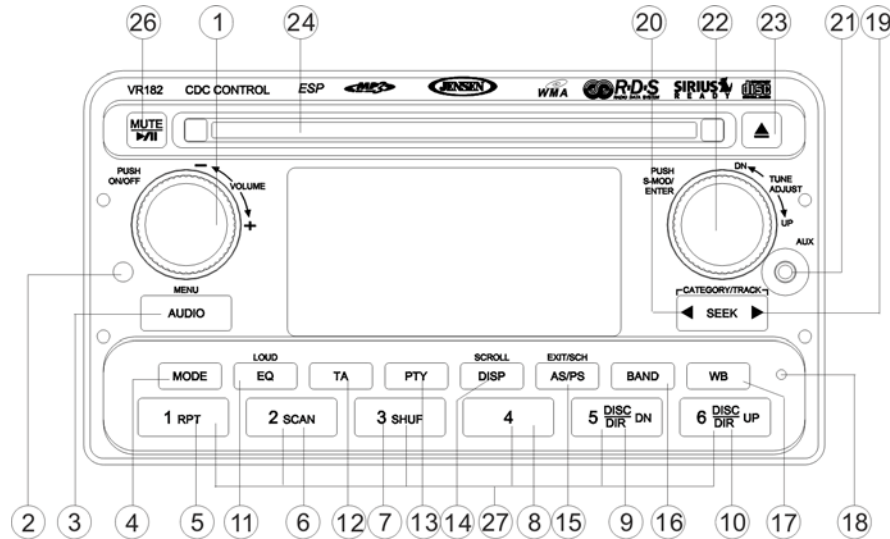

If AUTO IPOD "ON" is selected in the system menu, your iPod will play automatically when connected to the unit. "IPOD" will appear in the upper left corner of the display.

If AUTO IPOD "OFF" is selected in the system menu, your iPod will not play automatically when connected. In this case, press the **MODE** button (4) to change to IPOD mode.

If you press the **BAND**, **WB** or **MODE** button during iPod playback, the iPod will resume playback when you return to IPOD mode.

Selecting a Playlist

1. When an iPod is playing, press the **ENTER** button (22) to display the playlists on the LCD.
2. Rotate the **TUNE ADJUST UP/DN** button (22) to change the playlist between Artist / Album /Genre /Song / Composer.
3. Press **ENTER** to confirm the selected playlist.

Press the **EXIT (AS/PS)** button (15) to exit or back out of the current menu.

Controlling Playback

Pausing Playback

During playback, press the **>||** button (26) to pause the iPod player. "Pause" will appear on the LCD. Press **>||** again to resume playback.

Repeat Play

During playback, press the **RPT** button (5) to repeat the current song. "Repeat" will appear on the LCD. Press **RPT** again to stop repeat playback.

Random Play

During playback, press the **SHUF** button (7) to play all songs in the current category in random order. Random play will begin once the current song has finished playing. "Shuffle" will appear on the LCD. Press **SHUF** again to stop random playback.

Selecting Tracks

During playback, press the **SEEK </>** button (20/19) to play the previous or next track in the current category. Press the **SEEK <** button (20) once to play the song from the start position or press **SEEK <** twice to play the previous track.

Press and hold the **SEEK </>** button (20/19) to fast reverse/forward the song. iPod playback will continue when the button is released.

CD CHANGER OPERATION

After an optional CD changer has been installed and properly connected, press the reset button (11) to initialize the installation. Refer to the owner's manual included with the CD changer for instructions on installing, loading and using the CD magazine.

Switching to CDC Mode

Press the **MODE** button (4) until "CDC" appears on the LCD display. Playback begins with the first CD that the CD changer detects.

Controlling Disc Playback

Pausing Playback

Press the **>/||** button (26) to pause the CD player. Press **>/||** again to resume playback.

Selecting Tracks

Press the **SEEK <** (19) or **SEEK >** button (20) to move to the following or previous track. The track number appears on the LCD display.

Press and hold the **SEEK <** or **SEEK >** button to fast reverse or fast forward. Disc play starts when you release the button.

Previewing Tracks

Press the **SCAN** button (6) to play the first ten seconds of each track on the current disc. *Press and hold* the **SCAN** button to play first ten seconds of the first track on each disc in the CD magazine.

Press **SCAN** again to stop intro scan and listen to the current track.

Repeat Play

Press the **RPT** button (5) to continuously repeat the same track.

Press and hold the **RPT** button to continuously repeat all tracks on the current disc.

Press **RPT** again to stop repeat playback.

Random Play

Press the **SHUF** button (7) to play all tracks on the current disc in random order.

Press and hold the **SHUF** button to select a random disc and play the selected disc in random order. Press **SHUF** again to cancel the random playback.

Selecting a Disc

Press the **DISC DN** (9) or **DISC UP** button (10) to select the previous disc or next disc.

REMOTE CONTROLLERS

Steering Wheel Remote (SOLD SEPARATELY)

Installing the Steering Wheel Remote

Use the mounting bracket to attach the remote control to the steering wheel:

1. Use the screwdriver to remove the two screws on the bottom of the mounting cabinet and remove the cabinet.
2. Unfold the binding, then let the binding surround the pole of the steering wheel tightly. Adhere the soft-hook side to the hair curler side. The mounting base and the binding are fixed to the steering wheel.
3. Use the two screws to fix the mounting cabinet to the mounting base.

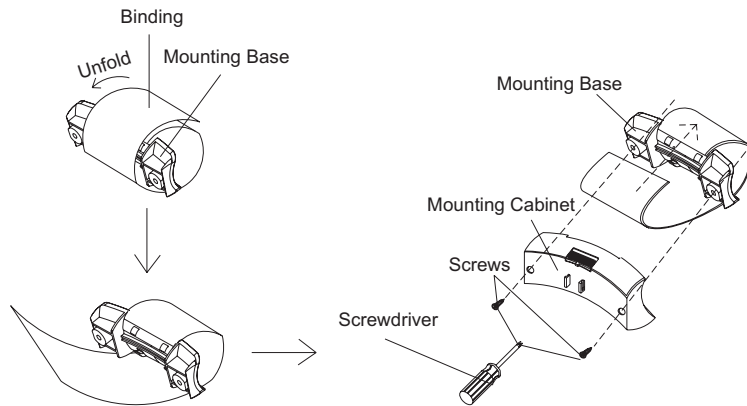

4. Fix the remote control to the mounting cabinet. Aim the outshoot on the mounting cabinet to the groove on the side of the remote control.

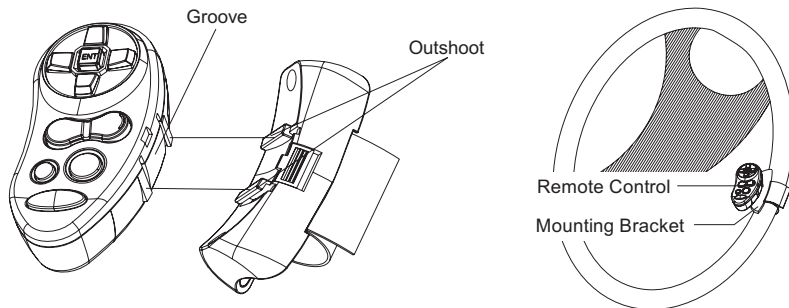

5. If the main unit is placed on the right side of the steering wheel, to operate the unit conveniently, you can install the remote control on the right pole of the steering wheel, then you can use the right hand to press the keys on the remote control to control the main unit.

Inserting the Battery

1. To open the battery compartment cover, push the cover marked "OPEN" on the back of the remote control.
2. Insert the new battery (CR2025 3V) into the battery compartment. Make sure the positive and negative terminals of the battery are oriented as indicated.
3. Close the cover.

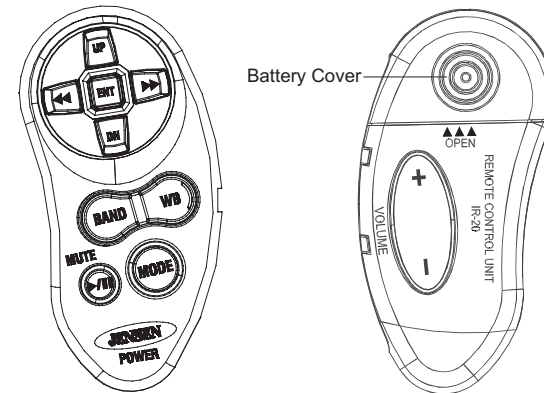

Key Functions

- **TUN +/-**: Changes frequency/channel by one step in AM/FM/SAT modes.
- **SEEK +/-**: Seeks to next strongest station in AM/FM modes. Skips to next/previous preset station in SAT mode.
- **PTY / PS**: Cycles though a list of RDS program types in FM radio mode (seek +/- is pressed to search the band for the selected program type). Scans all stored presets in SAT or radio mode (any button press during PS will stop the scan).
- **WB**: Directly access to weatherband.
- **MODE**: Cycles through all available play modes (Radio, CDP, CDC, SAT, iPod, Aux).

NOTE: If CDC, SAT or iPod hardware is not connected, the corresponding mode will be skipped in the sequence.

- **POWER**: Powers on/off.
- **MUTE (Play/Pause)**: Mutes audio in all modes. Pauses/resumes CD play in CDP/CDC modes.
- **BAND**: Sequences bands/preset-banks (AM1, AM2, FM1, FM2, FM3) in Radio mode. Sequences preset banks (SAT1, SAT2, SAT3) in satellite mode.
- **VOLUME +/-**: Adjusts volume level.

Credit Card Remote (SOLD SEPARATELY)

- **POWER:** Powers on/off.
- **MOD:** Cycles through all available play modes (Radio, CDP, CDC, SAT, iPod, Aux).
- **VOL:** Adjusts volume level.
- **AUD (MENU):** Accesses Audio and System Menu.
- **ENT (S-MOD):** Enter key.
- **TUNE/CH +/-:** Changes frequency/channel by one step in AM/FM/SAT modes.
- **MUTE:** Mutes audio in all modes.
- **WB:** Directly accesses to weatherband.
- **BAND:** Sequences bands/preset-banks (FM1, FM2, AM) in Radio mode. Sequences preset banks (SAT1, SAT2, SAT3) in satellite mode.
- **AS/PS (EXIT/SCH):** Scans all stored presets in SAT or radio mode (any button press during PS will stop the scan).
- **DISP (SCROLL):** Sets clock. Scrolls ID3 information.
- **DN/DISC/UP:** Moves to next/previous disc in CDC mode.
- **EQ (LOUD):** Turns on/selects preset Equalizer functions.
- **PTY:** Cycles through a list of RDS program types in FM radio mode (seek +/- is pressed to search the band for the selected program type). Scans all stored presets in SAT mode (any button press during PS will stop the scan).
- **TA:** Enters Traffic Announcement mode.
- **CATEGORY </>:** Changes category in SIRIUS/iPod mode.

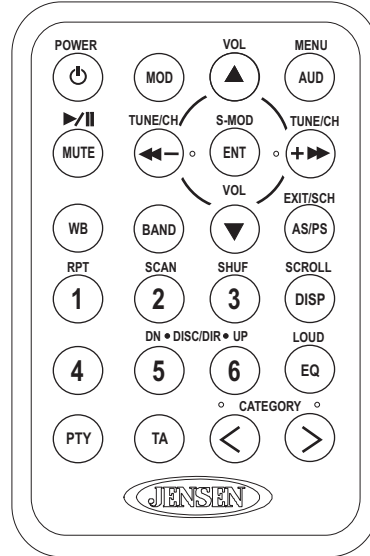

CARE AND MAINTENANCE

- Keep the product dry. If it does get wet, wipe it dry immediately. Liquids might contain minerals that can corrode the electronic circuits.
- Keep the product away from dust and dirt, which can cause premature wear of parts.
- Handle the product gently and carefully. Dropping it can damage circuit boards and cases, and can cause the product to work improperly.
- Wipe the product with a dampened cloth occasionally to keep it looking new. Do not use harsh chemicals, cleaning solvents, or strong detergents to clean the product.
- Use and store the product only in normal temperature environments. High temperature can shorten the life of electronic devices, damage batteries, and distort or melt plastic parts.

Ignition

The most common source of noise in reception is the ignition system. This is normally due to the fact that radio is placed relatively close to the ignition system (engine). This type of noise can be easily detected because it will vary in intensity of pitch with the speed of the engine.

Usually, the ignition noise can be suppressed considerably by using a radio suppression type high voltage ignition wire and suppressor resistor in the ignition system. (Most vehicles employ this wire and resistor but it may be necessary to check them for correct operation.) Another method of suppression is the use of additional noise suppressors. These can be obtained from most CB/A radio or electronic supply shops.

Interference

Radio reception in a moving environment (automobile) is very different from reception in a stationary (home). It is very important to understand the difference.

AM reception will deteriorate when passing through a tunnel or when passing under high voltage lines. Also, noise can be picked up from passing automobiles. Although AM is subject to environmental noise, it has the ability to be received at great distance. This is due to the fact that broadcasting signals follow the curvature of the earth and are reflected back by the upper atmosphere.

TROUBLESHOOTING

Symptom	Cause	Solution
No power	The vehicle's ignition is not on	If the power supply is properly connected to the vehicle accessory terminal, switch the ignition key to "ACC".
	The fuse is blown	Replace the fuse.
Disc cannot be loaded or ejected	Presence of CD disc inside the player	Remove the disc in the player and insert the new one.
	Inserting the disc in reverse direction	Insert the compact disc with the label facing upward.
	Compact disc is extremely dirty or disc is defective	Clean the disc or try to play a new one.
	Temperature inside the vehicle is too high	Wait until the ambient temperature returns to normal.
	Condensation	Leave the player off for an hour or so, then try again.
No sound	Volume is too low	Adjust volume to audible level.
	Wiring is not properly connected.	Check wiring connections.
The operation keys do not work	Control panel not properly installed	Reinstall control panel.
	The built-in microcomputer is not operating properly due to noise	Press the RESET button.
Sound skips	The installation angle is more than 30 degrees.	Adjust the installation angle to less than 30 degrees.
	The disc is dirty or defective.	Clean the disc and try to play again or use new disc.
Cannot tune to radio station, auto-seek does not work	The antenna cable is not connected.	Insert the antenna cable firmly.
	The signals are too weak.	Select a station manually.

SPECIFICATIONS

CD

Signal to Noise Ratio ≥ 60 dB
 Channel Separation : More than 50 dB
 Frequency Response : 40Hz - 18 kHz

FM Radio

Frequency Coverage (USA) 87.5 to 107.9 MHz
 Frequency Coverage (Europe) 87.5 to 108 MHz
 Intermediate Frequency 10.7 MHz
 Sensitivity (S/N=30dB) 4 μ V
 Image Rejection >45 dB
 Stereo Separation >25dB

AM/MW

Frequency Range (USA) 530-1710KHz
 Frequency Range (Europe) 522-1620KHz
 Intermediate Frequency 450KHz
 Sensitivity (S/N=20dB) 36 dB

General

Operating Voltage DC 12 Volts
 Grounding System Negative Ground
 Speaker Impedance 4-8 ohms per channel
 Tone Controls:
 Bass (at 100 Hz) : ± 10 dB
 Treble (at 10 kHz) : ± 10 dB
 Power Output 40W x 4
 Current Drain 15 Ampere (max.)
 Dimensions 80 (W) x 183 (D) x 100 (H)



AUDIOVOX SPECIALIZED APPLICATIONS, LLC

ASA Electronics Corporation

www.asaelectronics.com

© 2007 ASA Electronics Corporation

v.021907