

2-9501



*Cordless Telephone  
User's Guide*



*We bring good things to life.*

## FCC REGISTRATION INFORMATION

Your GE telephone equipment is registered with the Federal Communications Commission and is in compliance with parts 15 and 68, FCC Rules and Regulations.

### 1 Notification to the Local Telephone Company

On the bottom of this equipment is a label indicating, among other information, the FCC Registration number and Ringer Equivalence Number (REN) for the equipment. You must, upon request, provide this information to your telephone company.

The REN is useful in determining the number of devices you may connect to your telephone line and still have all of these devices ring when your telephone number is called. In most (but not all) areas, the sum of the RENs of all devices connected to one line should not exceed 5. To be certain of the number of devices you may connect to your line as determined by the REN, you should contact your local telephone company.

#### Notes

- This equipment may not be used on coin service provided by the telephone company.
- Party lines are subject to state tariffs, and therefore, you may not be able to use your own telephone equipment if you are on a party line. Check with your local telephone company.
- Notice must be given to the telephone company upon permanent disconnection of your telephone from your line.

### 2 Rights of the Telephone Company

Should your equipment cause trouble on your line which may harm the telephone network, the telephone company shall, where practicable, notify you that temporary discontinuance of service may be required. Where prior notice is not practicable and the circumstances warrant such action, the telephone company may temporarily discontinue service immediately. In case of such temporary discontinuance, the telephone company must: (1) promptly notify you of such temporary discontinuance; (2) afford you the opportunity to correct the situation; and (3) inform you of your right to bring a complaint to the Commission pursuant to procedures set forth in Subpart E of Part 68, FCC Rules and Regulations.

The telephone company may make changes in its communications facilities, equipment, operations or procedures where such action is required in the operation of its business and not inconsistent with FCC Rules and Regulations. If these changes are expected to affect the use or performance of your telephone equipment, the telephone company must give you adequate notice, in writing, to allow you to maintain uninterrupted service.

## INTERFERENCE INFORMATION

This device complies with Part 15 of the FCC Rules. Operation is subject to the following two conditions: (1) This device may not cause harmful interference; and (2) This device must accept any interference received, including interference that may cause undesired operation.

This equipment has been tested and found to comply with the limits for a Class B digital device, pursuant to Part 15 of the FCC Rules. These limits are designed to provide reasonable protection against harmful interference in a residential installation.

This equipment generates, uses, and can radiate radio frequency energy and, if not installed and used in accordance with the instructions, may cause harmful interference to radio communications. However, there is no guarantee that interference will not occur in a particular installation.

If this equipment does cause harmful interference to radio or television reception, which can be determined by turning the equipment off and on, the user is encouraged to try to correct the interference by one or more of the following measures:

- Reorient or relocate the receiving antenna (that is, the antenna for radio or television that is "receiving" the interference).
- Reorient or relocate and increase the separation between the telecommunications equipment and receiving antenna.
- Connect the telecommunications equipment into an outlet on a circuit different from that to which the receiving antenna is connected.
- Consult the dealer or an experienced radio/TV technician for help.

If these measures do not eliminate the interference, please consult your dealer or an experienced radio/television technician for additional suggestions. Also, the Federal Communications Commission has prepared a helpful booklet, "How To Identify and Resolve Radio/TV Interference Problems." This booklet is available from the U.S. Government Printing Office, Washington, D.C. 20402. Please specify stock number 004-000-00345-4 when ordering copies.

## HEARING AID COMPATIBILITY

This telephone system meets FCC standards for Hearing Aid Compatibility.

|  |
|--|
| FCC NUMBER IS LOCATED ON THE CABINET BOTTOM<br>REN NUMBER IS LOCATED ON THE CABINET BOTTOM |
|--|

# INTRODUCTION



Your GE cordless phone is designed to give you flexibility in use, and high quality performance. To get the most from your new phone, we suggest that you take a few minutes right now to read through this instruction manual.

## TABLE OF CONTENTS

|                                   |   |                                   |    |
|-----------------------------------|---|-----------------------------------|----|
| GETTING STARTED .....             | 2 | AUTOMATIC STANDBY .....           | 7  |
| CORDLESS TELEPHONE                |   | REDIAL BUTTON .....               | 7  |
| CHARACTERISTICS .....             | 2 | FLASH BUTTON .....                | 7  |
| MODULAR JACK REQUIREMENTS .....   | 2 | HANDSET SOUNDS .....              | 7  |
| INSTALLATION AND SETUP .....      | 3 | TEMPORARY TONE .....              | 8  |
| CHARGING THE HANDSET'S            |   | GENERAL PRODUCT CARE .....        | 9  |
| BATTERY PACK .....                | 5 | SERVICE .....                     | 9  |
| CORDLESS PHONE OPERATION          |   | HANDSET BATTERY INFORMATION ..... | 10 |
| AND FEATURES .....                | 6 | BATTERY SAFETY PRECAUTIONS .....  | 10 |
| SETTING THE VOLUME SWITCH .....   | 6 | CHANGING THE BATTERY .....        | 11 |
| MAKING AND RECEIVING CALLS .....  | 6 | TROUBLESHOOTING GUIDE .....       | 12 |
| MAKING A CALL .....               | 6 | ACCESSORY ORDER FORM .....        | 13 |
| RECEIVING A CALL WITH HANDSET IN  |   | ACCESSORY ORDER FORM .....        | 14 |
| THE BASE .....                    | 6 | INDEX .....                       | 15 |
| RECEIVING A CALL WITH HANDSET OUT |   | LIMITED WARRANTY .....            | 16 |
| OF THE BASE .....                 | 6 |                                   |    |

**NOTE:** Illustrations contained within this User's Guide are for representation only. Your unit may differ slightly.

**WARNING: TO PREVENT FIRE OR ELECTRICAL SHOCK HAZARD, DO NOT EXPOSE THIS PRODUCT TO RAIN OR MOISTURE.**

|  |   |  |
|--|---|--|
|   | <b>CAUTION</b><br>RISK OF ELECTRIC SHOCK<br>DO NOT OPEN   |   |
| THE LIGHTNING FLASH AND ARROW HEAD WITHIN THE TRIANGLE IS A WARNING SIGN ALERTING YOU OF "DANGEROUS VOLTAGE" INSIDE THE PRODUCT. | CAUTION: TO REDUCE THE RISK OF ELECTRIC SHOCK, DO NOT REMOVE COVER (OR BACK). NO USER-SERVICEABLE PARTS INSIDE. REFER SERVICE TO QUALIFIED SERVICE PERSONNEL. | THE EXCLAMATION POINT WITHIN THE TRIANGLE IS A WARNING SIGN ALERTING YOU OF IMPORTANT INSTRUCTIONS ACCOMPANYING THE PRODUCT. |
| SEE MARKING ON BOTTOM / BACK OF PRODUCT  |   |  |

## GETTING STARTED

---

Make sure your package includes the items shown here.



Antenna

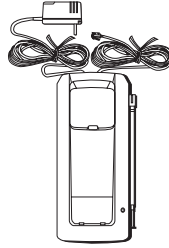

Base with telephone line cord  
and AC power adapter attached



Handset

## CORDLESS TELEPHONE CHARACTERISTICS

- A cordless telephone is dependent upon the availability of AC power. Any interruption of electrical power at your location would prevent your placing or receiving calls. Therefore, a cordless telephone *should not* be installed as the only phone in your home.
- The cordless handset's range away from the base depends upon many factors. In some areas, installing the base on the second floor will provide greater range than the ground floor installation. Reception can be adversely affected by such things as aluminum siding, appliances (refrigerators, stove, etc.) insulation foil backing, heating ducts and other metal construction which acts to shield radio signals. Atmospheric conditions also play an important role in the performance of your cordless telephone.
- Always keep the base antenna fully extended.
- Above all, keep within the range of the base.

## MODULAR JACK REQUIREMENTS

You need an RJ11 type modular jack, which is the most common type of phone jack and might look like the one pictured here. If you don't have a modular jack, call your local phone company to find out how to get one installed.

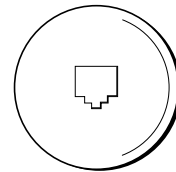

## INSTALLATION AND SETUP

1. Insert the handset antenna and screw into place.

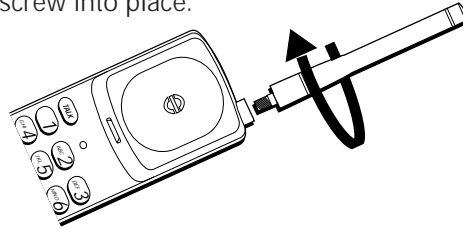

2. Set the TONE/ PULSE switch to PULSE if you have rotary service or TONE if you have touch-tone service. If you don't know which type of service you have, check with your phone company.

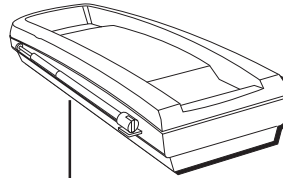

**TONE/ PULSE switch**

3. Plug the telephone line cord into the modular wall jack.
  - For the wall mount, slip the mounting holes (on the back of the base unit) over the wall plate posts and slide the base down until the unit is firmly in place. (Wall plate not provided.)

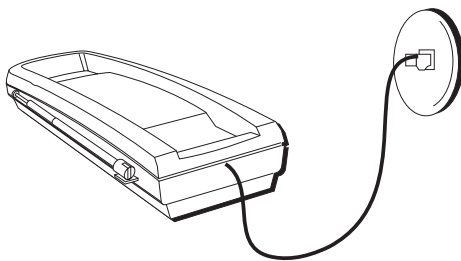

**Desk mount**

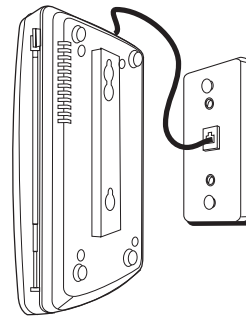

**Wall mount**

4. Plug the AC power supply cord into an electrical outlet which cannot be switched off. *Do not use* an outlet that can be turned on and off by a wall switch.

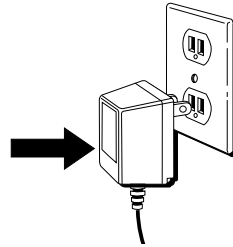

5. Raise and fully extend the antenna on the base, and then place the handset in the base to charge the battery for 12 or more hours.

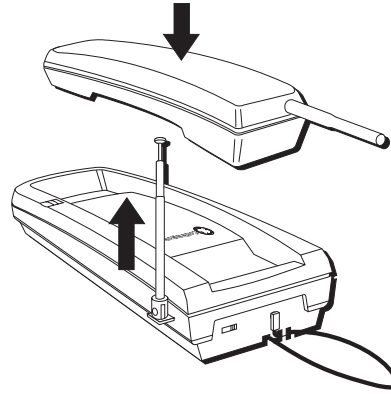

**NOTE:** Whenever a power interruption occurs or the batteries are replaced, the handset must be returned to the base to reset the security code.

## **CHARGING THE HANDSET'S BATTERY PACK**

Your cordless telephone is automatically charged when the handset is placed in the base cradle. To maintain adequate power, you need to charge the battery pack every few days by returning the handset to the base.

**NOTE:** Although you can leave the handset out of the base for extended periods, you will need to return it to the base periodically to keep the battery recharged.

**TIP:** Periodically clean the charging contacts on the handset and base with a soft cloth or a pencil eraser.

## **CORDLESS PHONE OPERATION AND FEATURES**

Using a cordless phone is pretty much the same as using a corded phone except that you have to press the TALK button after you pick up the handset before you can talk.

### **SETTING THE VOLUME SWITCH**

The VOL HI/LO controls the volume of the handset's earpiece when you're talking on the phone.

### **MAKING AND RECEIVING CALLS**

#### **MAKING A CALL**

The two things you need to know to make a call are:

1. Press the TALK button before you dial.
2. Press TALK or place the handset in the base to hang up.

#### **RECEIVING A CALL WITH HANDSET IN THE BASE**

1. When the phone rings lift the handset. The Phone-in-Use light will be ON and you can talk (Auto Answer Feature).
2. If you press the TALK button by accident within 2-3 seconds of lifting the handset out of the base, the phone will ignore your command. (After 2-3 seconds you will disconnect the line).
3. If the call is first answered on an extension phone and you wait 10 seconds after the last ring to lift the cordless handset, you will have to press the TALK button to talk.

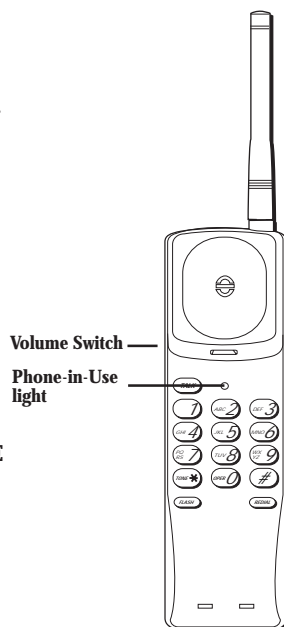

#### **RECEIVING A CALL WITH HANDSET OUT OF THE BASE**

To answer a call, you must press the TALK button before you can talk.

**NOTE:** The Phone-in-Use light comes on whenever the phone is on.



## **AUTOMATIC STANDBY**

You can leave the phone ON and place the handset in the base. It will automatically hang up.

When you pick up the handset the phone will be ON.

## **REDIAL BUTTON**

Press the REDIAL button to redial the last number you called. If you get a busy signal, and want to keep dialing the number, just press REDIAL again (you don't have to turn the phone off and back on).

## **FLASH BUTTON**

Use the FLASH button to activate customer calling services such as call waiting or call transfer, which are available through your local phone company.

- Do not use the TALK button to try to access calling services because you will hang up the phone.
- Do not use the FLASH button to hang up the phone.

## **HANDSET SOUNDS**

| <i>Sound</i>               | <i>Meaning</i>       |
|----------------------------|----------------------|
| A short beep with phone ON | Charge batteries     |
| A long tone with phone ON  | Out of range warning |

## TEMPORARY TONE

This feature enables pulse (rotary) service phone users to access touch-tone services — offered by banks, credit card companies, etc. — by pressing the tone button to temporarily make the phone touch-tone compatible.

To get information about your bank account, for example, you would:

1. Call the bank's information line.
2. Press the TONE ( \* ) button after your call is answered.
3. Follow the voice menu instructions to get the information. When you hang up, the phone goes back to pulse (rotary) service.

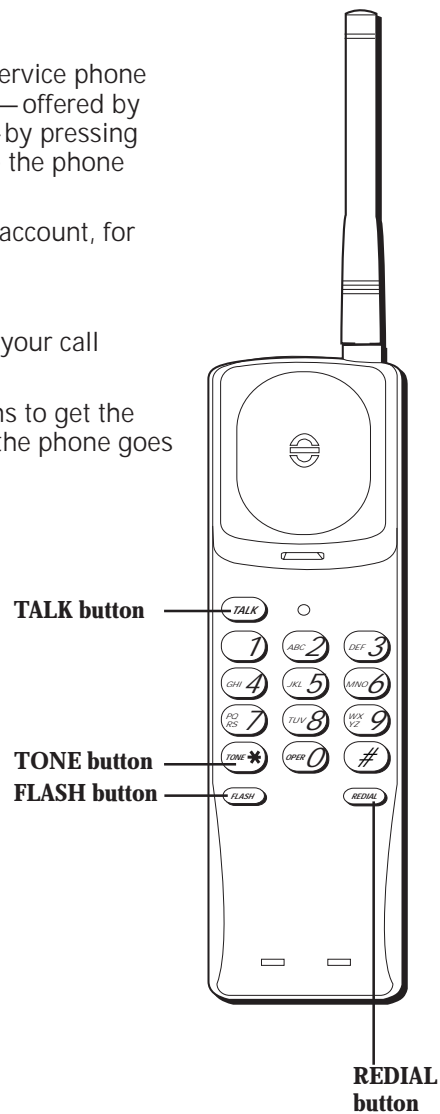

## **GENERAL PRODUCT CARE**

---

Follow these guidelines to keep your phone working well:

- Avoid putting the phone near heating appliances and devices that generate electrical noise (for example, motors or fluorescent lamps).
- DO NOT expose to direct sunlight or moisture.
- Avoid dropping the handset, and/or other rough treatment to the phone.
- Clean the phone with a soft cloth.
- Never use a strong cleaning agent or abrasive powder because this will damage the finish.
- Retain the original packaging in case you need to ship the phone at a later date.
- Periodically clean charge contacts on handset and base with a soft cloth.

## **SERVICE**

---

The FCC requires this product to be serviced only by the manufacturer or its authorized service agents. In accordance with FCC requirements, changes or modifications not expressly approved by Thomson Consumer Electronics could void the user's authority to operate this product. For instructions on how to obtain service, refer to the warranty included in this Guide.

Attach your sales receipt to the booklet for future reference or jot down the date this product was purchased or received as a gift. This information will be valuable if service should be required during the warranty period.

Purchase date \_\_\_\_\_ Name of store \_\_\_\_\_

## **HANDSET BATTERY INFORMATION**

---

### **BATTERY SAFETY PRECAUTIONS**

- Don't disassemble, mutilate, puncture, wet, or dispose of battery in fire. Like other batteries of this type, if it is burned or punctured, it could release toxic materials which can cause injury.
- Keep batteries out of the reach of children.



**NOTE:** The RBRC seal on the battery used in your Thomson Consumer Electronics product indicates that we are participating in a program to collect and recycle Nickel Cadmium batteries throughout the United States. Please call 1-800-8-BATTERY for information or contact your local recycling center.

## CHANGING THE BATTERY

Make sure the phone is *OFF* when you replace the battery.

1. Slide open the battery compartment door.
2. Remove the retaining strap that holds the battery in place.

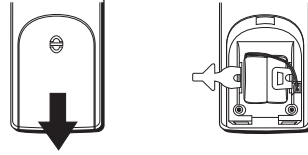

3. Pull out the battery pack, and then remove the battery plug.
4. Replace and plug in the new battery pack (use catalog #BT-28).

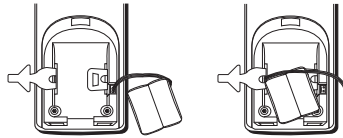

5. Replace the plastic tab.
6. Replace battery door.

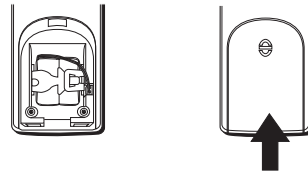

7. Return handset to the base unit for 12 hours before using the handset so that the battery is adequately charged.

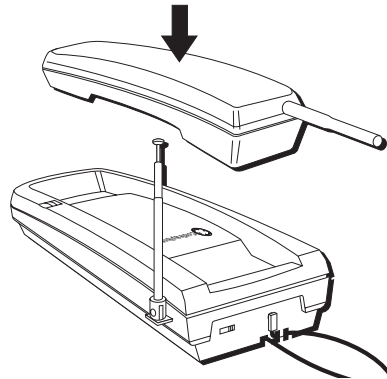

## TROUBLESHOOTING GUIDE

---

| <i>Problem</i>                                    | <i>Solution</i>   |
|---|---|
| No dial tone                                      | <ul style="list-style-type: none"><li>• Check installation:<ul style="list-style-type: none"><li>— Is the base power cord connected to a working outlet?</li><li>— Is the Phone-in-Use light on?</li><li>— Is the telephone line cord connected to the base unit and the wall jack?</li></ul></li><li>• Connect another phone to the same jack. The problem might be your wiring or local service.</li><li>• Is the handset out of range of the base?</li><li>• Make sure the battery is properly charged.</li><li>• Is the battery pack installed correctly?</li><li>• Did the handset beep when you pressed the TALK button? Did the Phone-in-Use light come on? You may need to charge the battery.</li><li>• Reset the security code by placing the handset in the base for about 20 seconds.</li></ul> |
| Dial tone is OK, but can't dial out               | <ul style="list-style-type: none"><li>• Make sure the TONE/PULSE switch on the base is correctly set.</li></ul>   |
| Handset does not ring                             | <ul style="list-style-type: none"><li>• You may have too many extension phones on your line. Try unplugging some phones.</li></ul>  |
| You experience static, noise or fading in and out | <ul style="list-style-type: none"><li>• Move closer to the base (the handset might be out of range).</li><li>• Does the the base need to be relocated? Make sure the base is not plugged into an outlet with another household appliance.</li><li>• Charge the battery.</li></ul>   |
| Unit beeps  | <ul style="list-style-type: none"><li>• Place the handset in the base for 20 seconds. If it still beeps, charge the battery for 12 hours.</li><li>• Clean the charging contacts on the handset and base with a soft cloth or an eraser.</li><li>• See solutions for "No dial tone."</li><li>• Replace the battery.</li></ul>  |

----- CUSTOMER: CUT ALONG DOTTED LINE. ✂ -----

## ACCESSORY ORDER FORM

| DESCRIPTION                 | CATALOG NUMBER | PRICE*  | QUANTITY | TOTAL |
|-----------------------------|----------------|---------|----------|-------|
| Replacement handset battery | BT-28          | \$14.95 |          |       |
| Rubber Antenna              | 5-2412         | \$9.95  |          |       |

**For credit card purchases**

Your complete charge card number, its expiration date and your signature are necessary to process all charge card orders.

Copy your complete account number from your **VISA** card.

|                      |                      |                      |                      |                      |                      |                      |                      |                      |                      |                      |                      |                      |                      |                      |                      |                      |                      |                      |                      |
|----------------------|----------------------|----------------------|----------------------|----------------------|----------------------|----------------------|----------------------|----------------------|----------------------|----------------------|----------------------|----------------------|----------------------|----------------------|----------------------|----------------------|----------------------|----------------------|----------------------|
| <input type="text"/> | <input type="text"/> | <input type="text"/> | <input type="text"/> | <input type="text"/> | <input type="text"/> | <input type="text"/> | <input type="text"/> | <input type="text"/> | <input type="text"/> | <input type="text"/> | <input type="text"/> | <input type="text"/> | <input type="text"/> | <input type="text"/> | <input type="text"/> | <input type="text"/> | <input type="text"/> | <input type="text"/> | <input type="text"/> |
|----------------------|----------------------|----------------------|----------------------|----------------------|----------------------|----------------------|----------------------|----------------------|----------------------|----------------------|----------------------|----------------------|----------------------|----------------------|----------------------|----------------------|----------------------|----------------------|----------------------|

My card expires:

|                      |                      |                      |                      |
|----------------------|----------------------|----------------------|----------------------|
| <input type="text"/> | <input type="text"/> | <input type="text"/> | <input type="text"/> |
|----------------------|----------------------|----------------------|----------------------|

Copy your complete account number from your **MasterCard**.

|                      |                      |                      |                      |                      |                      |                      |                      |                      |                      |                      |                      |                      |                      |                      |                      |                      |                      |                      |                      |
|----------------------|----------------------|----------------------|----------------------|----------------------|----------------------|----------------------|----------------------|----------------------|----------------------|----------------------|----------------------|----------------------|----------------------|----------------------|----------------------|----------------------|----------------------|----------------------|----------------------|
| <input type="text"/> | <input type="text"/> | <input type="text"/> | <input type="text"/> | <input type="text"/> | <input type="text"/> | <input type="text"/> | <input type="text"/> | <input type="text"/> | <input type="text"/> | <input type="text"/> | <input type="text"/> | <input type="text"/> | <input type="text"/> | <input type="text"/> | <input type="text"/> | <input type="text"/> | <input type="text"/> | <input type="text"/> | <input type="text"/> |
|----------------------|----------------------|----------------------|----------------------|----------------------|----------------------|----------------------|----------------------|----------------------|----------------------|----------------------|----------------------|----------------------|----------------------|----------------------|----------------------|----------------------|----------------------|----------------------|----------------------|

Copy the number above your name on the **MasterCard**

|                      |                      |                      |                      |
|----------------------|----------------------|----------------------|----------------------|
| <input type="text"/> | <input type="text"/> | <input type="text"/> | <input type="text"/> |
|----------------------|----------------------|----------------------|----------------------|

My card expires:

|                      |                      |                      |                      |
|----------------------|----------------------|----------------------|----------------------|
| <input type="text"/> | <input type="text"/> | <input type="text"/> | <input type="text"/> |
|----------------------|----------------------|----------------------|----------------------|

\*Prices are subject to change without notice.

Total Merchandise.....\$ \_\_\_\_\_

Sales Tax.....\$ \_\_\_\_\_

We are required by law to collect the appropriate sales tax for each individual state, county, and locality to which the merchandise is being sent.

Shipping, Handling, and Insurance.....\$ **\$5.00**

Use **VISA** or MasterCard preferably. Money order or check must be in U.S. currency only. No COD or Cash.

All accessories are subject to availability. Where applicable, we will ship a superseding model.

Total Amount Enclosed.....\$ \_\_\_\_\_

Mail order form and money order or check (in U.S. currency) made payable to Thomson Consumer Electronics, Inc. to:

**Consumer Electronics**

**Mail Order Department**

**P.O. Box 8419**

**Ronks, PA 17573-8419**

This is your return label. Please print clearly.

To:

Name \_\_\_\_\_

Address \_\_\_\_\_ Apt. \_\_\_\_\_

City \_\_\_\_\_ State \_\_\_\_\_ ZIP \_\_\_\_\_

Authorized Signature \_\_\_\_\_

**Please make sure that this form has been filled out completely.**

## **ACCESSORY ORDER FORM**

---

To fulfill your communicating needs and enhance your lifestyle, a wide range of GE extension phones, main phones, cordless phones and answering systems is available.

Just stop by your nearest retailer and ask to see the wide range of GE telephone products.

All are carefully engineered to offer you high quality and dependability, modern easy-to-use features, and elegant styling at an affordable price.

Should you wish to purchase, insist on the GE brand for all your communicating needs.





## INDEX

---

### *A*

Accessory Order Form 13, 14  
Automatic Standby 7

### *B*

Battery, Changing 11  
Battery Safety 10  
Buttons  
    FLASH 7  
    PHONE ON/OFF 6  
    REDIAL 7  
    TONE 8

### *C*

Charging Handset Battery 5  
Cordless Phone Operation  
    and Features 6

### *F*

FLASH Button 7

### *G*

General Product Care 9  
Getting Started 2

### *H*

Handset Battery Information 10  
Handset Sounds 7

### *I*

Installation 3

### *M*

Making Calls 6  
Modular Jack 2

### *P*

PHONE Button 6  
PHONE ON/OFF 6  
Phone-in-Use light 6  
Product Care 9

### *R*

Receiving Calls 6  
REDIAL 7  
RINGER Switch 6

### *S*

Service 9

### *T*

Temporary Tone Feature 8  
TONE Button 8  
Troubleshooting Guide 12

## LIMITED WARRANTY

---

*What your warranty covers:*

- Any defect in materials or workmanship.

*For how long after your purchase:*

- One year.  
(The warranty period for rental units begins with the first rental or 45 days from date of shipment to the rental firm, whichever comes first.)

*What we will do:*

- Provide you with a new or, at our option, a refurbished unit.
- The exchange unit is under warranty for the remainder of the original product's warranty period.

*How to make a warranty claim:*

- Properly pack your unit. Include any cables, etc., which were originally provided with the product. We recommend using the original carton and packing materials.
- Include in the package evidence of purchase date such as the bill of sale. Also print your name and address and a description of the defect. Send standard UPS or its equivalent to:

*Thomson Consumer Electronics, Inc.  
Product Exchange Center  
32B Spur Drive  
El Paso, Texas 79906*

- Pay any charges billed to you by the Exchange Center for service not covered by the warranty.
- Insure your shipment in case of loss or damage. Thomson accepts no liability in case of damage or loss.
- A new or refurbished unit will be shipped to you prepaid freight.

*What your warranty does not cover:*

- Customer instruction. (Your Owner's Manual provides information regarding operating instructions and user controls. For additional information, ask your dealer.)
- Installation and set-up service adjustments.
- Batteries.
- Damage from misuse or neglect.
- Products which have been modified or incorporated into other products.
- Products purchased or serviced outside the USA.
- Acts of God, such as but not limited to lightning damage.

*Product Registration:*

- Please complete and mail the Product Registration Card packed with your unit. It will make it easier to contact you should it ever be necessary. The return of the card is not required for warranty coverage.

*How state law relates to this warranty:*

- This warranty gives you specific legal rights, and you may have other rights which vary from state to state.

*If you purchased your product outside the USA:*

- This warranty does not apply. Contact your dealer for warranty information.

Model 2-9501  
20805120 (Rev. 1)  
97-25  
Printed in Philippines

 **THOMSON CONSUMER ELECTRONICS**

© 1997 Thomson Consumer Electronics, Inc.  
P.O. BOX 1976, Indianapolis, IN 46206  
Trademark(s) ® Registered  
Marca(s) ® Registras