

BEKO

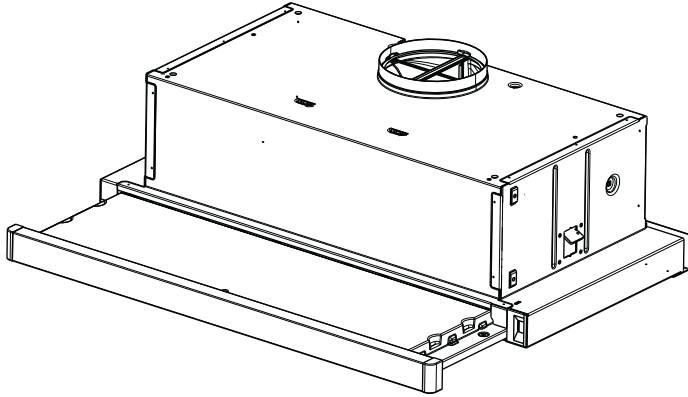

Instructions Manual

CTB 6407 - CTB 9407

INDEX

RECOMMENDATIONS AND SUGGESTIONS	3
CHARACTERISTICS	4
INSTALLATION.....	5
USE	7
MAINTENANCE	8

RECOMMENDATIONS AND SUGGESTIONS

⚠ The Instructions for Use apply to several versions of this appliance. Accordingly, you may find descriptions of individual features that do not apply to your specific appliance.

INSTALLATION

- The manufacturer will not be held liable for any damages resulting from incorrect or improper installation.
- The minimum safety distance between the cooker top and the extractor hood is 650 mm (some models can be installed at a lower height, please refer to the paragraphs on working dimensions and installation).
- Check that the mains voltage corresponds to that indicated on the rating plate fixed to the inside of the hood.
- For Class I appliances, check that the domestic power supply guarantees adequate earthing.
Connect the extractor to the exhaust flue through a pipe of minimum diameter 120 mm. The route of the flue must be as short as possible.
- Do not connect the extractor hood to exhaust ducts carrying combustion fumes (boilers, fireplaces, etc.).
- If the extractor is used in conjunction with non-electrical appliances (e.g. gas burning appliances), a sufficient degree of aeration must be guaranteed in the room in order to prevent the backflow of exhaust gas. The kitchen must have an opening communicating directly with the open air in order to guarantee the entry of clean air. When the cooker hood is used in conjunction with appliances supplied with energy other than electric, the negative pressure in the room must not exceed 0,04 mbar to prevent fumes being drawn back into the room by the cooker hood.
- In the event of damage to the power cable, it must be replaced by the manufacturer or by the technical service department, in order to prevent any risks.

USE

- The extractor hood has been designed exclusively for domestic use to eliminate kitchen smells.
- Never use the hood for purposes other than for which it has been designed.
- Never leave high naked flames under the hood when it is in operation.
- Adjust the flame intensity to direct it onto the bottom of the pan only, making sure that it does not engulf the sides.
- Deep fat fryers must be continuously monitored during use: overheated oil can burst into flames.
- Do not flambè under the range hood; risk of fire
- This appliance is not intended for use by persons (including children) with reduced physical, sensory or mental capabilities, or lack of experience and knowledge, unless they have been given supervision or instruction concerning use of the appliance by a person responsible for their safety.
- Children should be supervised to ensure that they do not play with the appliance.
- "CAUTION: Accessible parts may become hot when used with cooking appliances."

MAINTENANCE

- Switch off or unplug the appliance from the mains supply before carrying out any maintenance work.
- Clean and/or replace the Filters after the specified time period (Fire hazard).
- Clean the hood using a damp cloth and a neutral liquid detergent.

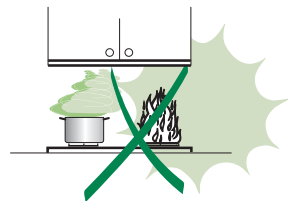
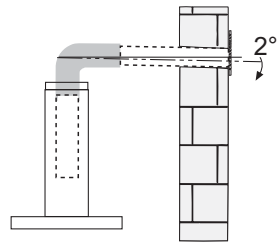
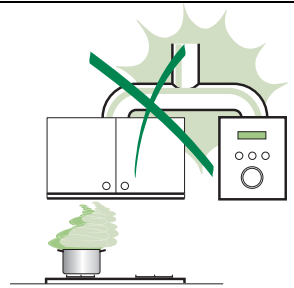

The symbol  on the product or on its packaging indicates that this product may not be treated as household waste. Instead it shall be handed over to the applicable collection point for the recycling of electrical and electronic equipment. By ensuring this product is disposed of correctly, you will help prevent potential negative consequences for the environment and human health, which could otherwise be caused by inappropriate waste handling of this product. For more detailed information about recycling of this product, please contact your local city office, your household waste disposal service or the shop where you purchased the product.

CHARACTERISTICS

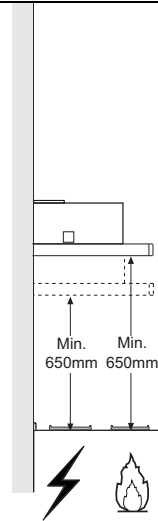
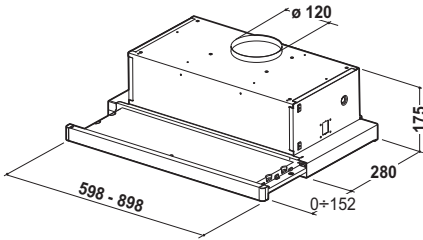

Components

Ref.	Q.ty	Product Components
1	1	Hood Body, complete with: Controls, Light, Blower, Filters
8	1	Directional Air Outlet grille
20	1	Closing element

Ref.	Q.ty	Installation Components
12a	4	Screws 4,2 x 44,4
12e	2	Screws 2,9 x 9,5

Q.ty	Documentation
1	Instruction Manual

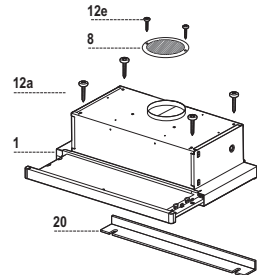

INSTALLATION

Drilling the Support surface and Fitting the Hood

SCREW FITTING

- The hood support surface must be 135 mm above the bottom surface of the wall units.
- Drill the support with a $\varnothing 4,5$ mm drill bit, using the drilling template provided.
- Cut a hole $\varnothing 125$ mm in size on the support surface, using the drilling template provided.
- Fix using the 4 screws **12a** (4,2 x 44,4) provided.

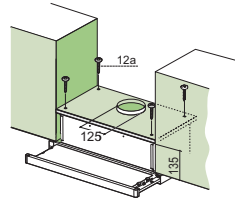

CLOSING ELEMENT

- The space between the edge of the hood and the rear wall can be closed by applying the element **20** provided, using the screws supplied for this purpose.

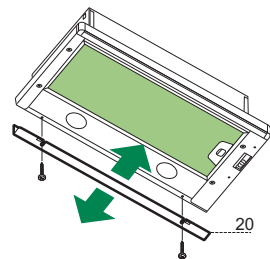

Connections

DUCTED VERSION AIR EXHAUST SYSTEM

When installing the ducted version, connect the hood to the chimney using either a flexible or rigid pipe $\varnothing 120$ mm, the choice of which is left to the installer.

- Fix the pipe in position using sufficient pipe clamps (not supplied).
- Remove any activated charcoal filters.

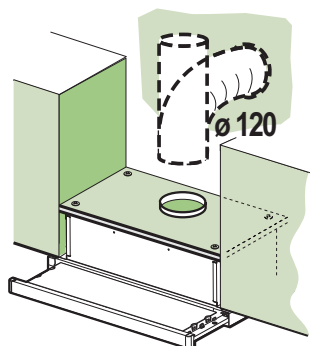

RECIRCULATION VERSION AIR OUTLET

- Cut a hole $\varnothing 125$ mm in any shelf that may be positioned over the hood.
- Connect the flange to the outlet on the shelf over the hood using a flexible or rigid pipe $\varnothing 120$ mm.
- Fix the pipe in position using sufficient pipe clamps (not supplied).
- Fix the directional grille **8** on the recirculation air outlet using the 2 screws **12e** (2,9 x 9,5) provided.
- Ensure that the activated charcoal filters have been inserted.

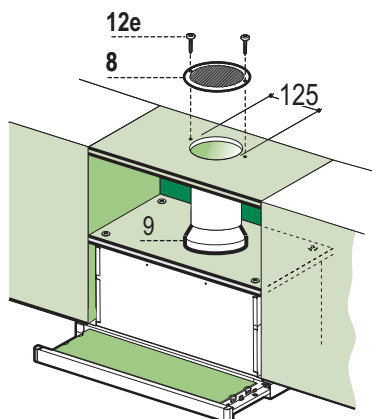

ELECTRICAL CONNECTION

- Connect the hood to the mains through a two-pole switch having a contact gap of at least 3 mm.
- When opening the sliding carriage for the first time after installing the hood, pull it out briskly until it clicks.

Control panel

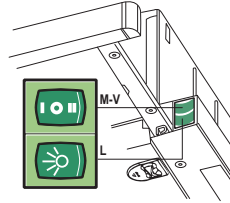
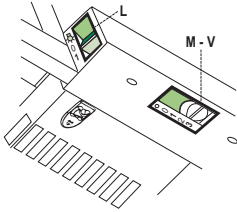

L	Light	Switches the lighting system on and off.	L	Light	Switches the lighting system on and off.
M	Motor	Switches the extractor motor on and off.	M	Motor	Switches the extractor motor on and off.
V	Speed	Sets the operating speed of the extractor:	V	Speed	Sets the operating speed of the extractor:
		<ol style="list-style-type: none"> 1. Low speed, used for a continuous and silent air change in the presence of light cooking vapour. 2. Medium speed, suitable for most operating conditions given the optimum treated air flow/noise level ratio. 3. Maximum speed, used for eliminating the highest cooking vapour emission, including long periods. 			<ol style="list-style-type: none"> 1. Low speed, used for a continuous and silent air change in the presence of light cooking vapour. 2. Medium speed, suitable for most operating conditions given the optimum treated air flow/noise level ratio.

MAINTENANCE

Grease filters

CLEANING METAL CASSETTE GREASE FILTERS

- The filters must be cleaned every 2 months, or more frequently in case of particularly heavy use of the hood. Filters can be washed in a dishwasher.
- Pull out the sliding suction panel.
- Remove the filters one by one, after having disconnected the relative fastening elements.
- Wash the filters, taking care not to bend them. Let them get dry before refitting them. (The colour of the filter surface may change throughout the time but this has no influence to the filter efficiency).
- When refitting the filters, make sure that the handle is visible on the outside.
- Close the sliding suction panel.

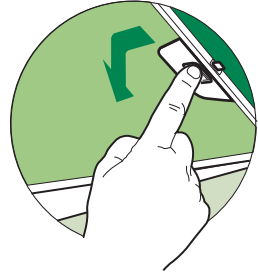

Charcoal filter (Recycling version)

REPLACING CHARCOAL FILTERS

Warning: Turn the lights off and wait until the lamps cool down before you change the odour filter.

- These filters are not washable and cannot be regenerated, and must be replaced approximately every four months or more frequently by particularly heavy use.
- Pull out the sliding suction panel.
- Remove the grease filters.
- Remove the saturated carbon filter by releasing the fixing hooks
- Fit the new filter by hooking it into its seating.
- Replace the grease filters.
- Close the sliding suction panel.

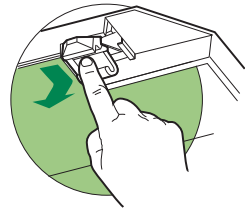

Lighting

LIGHT REPLACEMENT

28 W incandescent light.

- Remove the metal grease filters.
- Unscrew the bulbs and replace them with new ones having the same characteristics.
- Replace the metal grease filters.

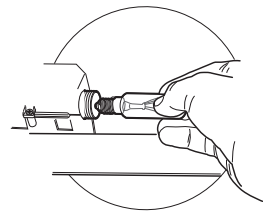



Beko Manufacturers Guarantee

Congratulations on purchasing a quality Beko product. Beko automatically provide you with a 2 year Manufacturers Guarantee, covering parts and labour for servicing within the geographical limits of Australia and New Zealand.

General Terms and Conditions

For Australian Consumers

This guarantee is an extra benefit and does not affect your legal rights. Our goods come with guarantees that cannot be excluded under the Australian Consumer Law. You are entitled to a replacement or refund for a major failure and for compensation for any other reasonably foreseeable loss or damage. You are also entitled to have the goods repaired or replaced if the goods fail to be of acceptable quality and the failure does not amount to a major failure.

For New Zealand Consumers

This guarantee is an extra benefit and does not affect your legal rights. Nothing in this guarantee purports to modify or exclude the conditions, guarantees and undertakings, and other legal rights, under the New Zealand Consumer Guarantees Act and other laws, except in those circumstances contemplated by section 43(2) of the New Zealand Consumer Guarantees Act.

Beko Guarantee

The Beko Manufacturers' Guarantee provides additional protection for your **Beko Product, and it identifies a preferred approach to resolving product claims** which will allow for a quick and simple process for all parties, subject to our terms and conditions below.

To enable us to assist you in the most expedient way please contact us by phoning the Toll free number (relative to your country of residence) as listed below. Please ensure you refer to your user manual and in particular the section headed "**Recommended Solutions for the problems**" before phoning.

The commencement date of this guarantee starts on the day of purchase and proof of purchase must be supplied to the Beko Service Centre prior to commencement of any guarantee work.

Terms and Conditions

Beko Australia and New Zealand Pty Ltd guarantees to the original purchaser to repair, or at its option replace, without charge to the owner for any part which is not of 'acceptable quality' within two years of date of purchase.

"No Lemon Guarantee" * if the product fails more than 2 times during the Guarantee period due to the same type failure caused by the same part, we will automatically replace the product with an equivalent product free of charge.

Food Spoilage*

If your product is a fridge or freezer, we will reimburse you for food which due to a valid fault as per our guarantee is spoilt; reimburse you as per the **benefits below:**

Up to 200 Litre	\$100.00
>200 Litre - 400 Litre	\$200.00
>400 Litre - 600 Litre	\$300.00
>600 litre	\$350.00

* Subject to a valid claim under the terms and conditions of this Guarantee

To be eligible for this Guarantee the product must be purchased from an Authorised Reseller in Australia or New Zealand.

What is not covered under this Guarantee

1. Any service calls in which the problem is found not to be caused or related to any defect in the Product. In this instance, the cost of the service call will be charged to you. Examples (but not limited too) of no product fault listed below:
 - a. Correcting the installation, e.g. levelling of product, adjustment of drain crossed or kinked hoses, leakage of hoses if **incorrectly fitted, removal of transit bolts (front loading washers)**, noises due to water hammer and/or power supplies.
 - b. Replacing fuses or correcting house power wiring or house plumbing issues.
 - c. Failure due to incorrect set up or requiring instructions normally covered in user manual.
 - d. Blocked pumps, removal of foreign objects/substances from the washing machine, e.g. socks, bra wires, dirt etc.
 - e. Normal noise or vibration
 - f. Infestation of pests, insects or vermin

2. This Guarantee does not cover damage caused by:
- a. Misuse or abuse of the Beko Product
 - b. Accidental damage of any kind
 - c. Rust and Corrosion where the product is located within a corrosive environment
 - d. Discolouration of burners or trivets on gas cooktops or chrome surrounds
 - e. Incorrect operation or not following the operation instructions as stated in the user manual.
 - f. Improper installation
 - g. Failure to clean or improper cleaning
 - h. Use of incorrect non – compliant electrical or gas connections
 - i. External sources including but not limited to electrical interference, power surges or voltage fluctuations.
 - j. Any loss caused by civil commotion
 - k. Any loss caused from extreme events of nature including but not limited to, flood, cyclone, severe storm and earthquake
 - l. Use of non genuine/authorised parts
 - m. Any repair or other work carried out on the Beko product other than by an Authorised Beko Service Personnel.
3. This Guarantee does not cover costs associated with replacing and servicing of consumable parts. E.g. lamps & bulbs, filters

This Guarantee has been designed for Products used in normal domestic environment. Our products are not designed for commercial use. Any commercial use may affect this Product's Guarantee.

Service under this Manufacturer's Guarantee is provided by the Beko Australia and New Zealand Authorised Repairer.

The Guarantee is provided by Beko Australia and New Zealand Pty Ltd (ABN: 49 152 055 162) of 55 Blanck Street, Ormeau, QLD Australia 4208, P O Box 354 Ormeau QLD Australia 4208.

In Australia if you need assistance.... Toll Free 1300 282 356

Email: Beko.care@Beko.com

In New Zealand if you need assistance.... Toll Free 0800 69 2356

Email: Beko.care@Beko.com

CE