

# ONKYO®

## Super Audio CD & DVD Audio/Video Changer

# DV-CP802

## Instruction Manual

Thank you for purchasing an Onkyo DVD Changer. Read this manual carefully before using your new DVD Changer. A good understanding of its features and operation will allow you to achieve optimum performance and enjoyment.

Keep this manual for future reference.

## Contents

Important Safety Instructions ..... 3

Precautions ..... 4

Introduction ..... 6

Getting to Know the DV-CP802 .... 11

Before Using the DV-CP802..... 16

Connecting the DV-CP802 ..... 17

Turning On the DV-CP802 & First  
Time Setup ..... 21

Basic Playback ..... 23

Advanced Playback..... 35

Configuring the DV-CP802..... 46

Troubleshooting ..... 60

Specifications..... 62



# Contents

---

---

<b>Precautions</b> .....	<b>4</b>	<b>Advanced Playback</b> .....	<b>35</b>
<b>Introduction</b> .....	<b>6</b>	Time Search .....	35
Supplied Accessories.....	6	Repeat Playback .....	35
DV-CP802 Features.....	6	A–B Repeat Playback .....	36
Disc Notes.....	7	Random Playback .....	37
Terminology .....	9	Memory Playback.....	38
<b>Getting to Know the DV-CP802</b> .....	<b>11</b>	Selecting Camera Angles.....	40
Front Panel .....	11	Selecting Languages & Audio Formats ...	41
Display .....	12	Selecting Subtitles .....	41
Rear Panel .....	13	Using Progressive Scanning .....	41
Remote Controller.....	14	Using Last Memory .....	42
<b>Before Using the DV-CP802</b> .....	<b>16</b>	Displaying Information.....	42
Installing the Remote’s Batteries .....	16	Turning Off the Video Circuits .....	45
Using the Remote Controller.....	16	<b>Configuring the DV-CP802</b> .....	<b>46</b>
<b>Connecting the DV-CP802</b> .....	<b>17</b>	Using the Onscreen Setup Menus .....	48
Before Making Any Connections.....	17	Picture Menu .....	48
AV Cables & Connectors .....	17	Audio Menu .....	50
Connecting Your TV or Projector .....	18	Language Menu .....	56
Connecting an AV Receiver .....	19	Display Menu.....	57
Connecting a Stereo Amp.....	20	Operation Menu.....	57
Connecting Components with <b>RI</b> .....	20	Initial Setup Menu.....	59
<b>Turning On the DV-CP802 &amp;</b>		Selecting Other Languages.....	59
<b>First Time Setup</b> .....	<b>21</b>	Language Code List .....	59
Turning On the DV-CP802.....	21	<b>Troubleshooting</b> .....	<b>60</b>
First Time Setup.....	21	<b>Specifications</b> .....	<b>62</b>
<b>Basic Playback</b> .....	<b>23</b>		
Loading Discs .....	23		
Loading Discs During Playback .....	24		
Selecting Discs .....	24		
Starting, Pausing & Stopping Playback ..	25		
Navigating Disc Menus .....	26		
Selecting Titles & Chapters by Number ..	27		
Using the Disc Navigator .....	28		
Memory Playback in the Disc Navigator .	29		
Selecting Tracks by Number.....	30		
Fast Forward & Reverse .....	31		
Frame-by-Frame Playback.....	31		
Slow-motion Playback.....	32		
Adjusting the Display Brightness .....	32		
Using JPEG CDs .....	33		
Using Chain Mode .....	34		

## WARNING:

TO REDUCE THE RISK OF FIRE OR ELECTRIC SHOCK, DO NOT EXPOSE THIS APPARATUS TO RAIN OR MOISTURE.

## CAUTION:

TO REDUCE THE RISK OF ELECTRIC SHOCK, DO NOT REMOVE COVER (OR BACK). NO USER-SERVICEABLE PARTS INSIDE. REFER SERVICING TO QUALIFIED SERVICE PERSONNEL.



**WARNING**  
RISK OF ELECTRIC SHOCK  
DO NOT OPEN

**AVIS**  
RISQUE DE CHOC ELECTRIQUE  
NE PAS OUVRIR



The lightning flash with arrowhead symbol, within an equilateral triangle, is intended to alert the user to the presence of uninsulated "dangerous voltage" within the product's enclosure that may be of sufficient magnitude to constitute a risk of electric shock to persons.



The exclamation point within an equilateral triangle is intended to alert the user to the presence of important operating and maintenance (servicing) instructions in the literature accompanying the appliance.

## Important Safety Instructions

1. Read these instructions.
2. Keep these instructions.
3. Heed all warnings.
4. Follow all instructions.
5. Do not use this apparatus near water.
6. Clean only with dry cloth.
7. Do not block any ventilation openings. Install in accordance with the manufacturer's instructions.
8. Do not install near any heat sources such as radiators, heat registers, stoves, or other apparatus (including amplifiers) that produce heat.
9. Do not defeat the safety purpose of the polarized or grounding-type plug. A polarized plug has two blades with one wider than the other. A grounding type plug has two blades and a third grounding prong. The wide blade or the third prong are provided for your safety. If the provided plug does not fit into your outlet, consult an electrician for replacement of the obsolete outlet.
10. Protect the power cord from being walked on or pinched particularly at plugs, convenience receptacles, and the point where they exit from the apparatus.
11. Only use attachments/accessories specified by the manufacturer.
12. Use only with the cart, stand, tripod, bracket, or table specified by the manufacturer, or sold with the apparatus. When a cart is used, use caution when moving the cart/apparatus combination to avoid injury from tip-over.  

PORTABLE CART WARNING  
S3125A
13. Unplug this apparatus during lightning storms or when unused for long periods of time.
14. Refer all servicing to qualified service personnel. Servicing is required when the apparatus has been damaged in any way, such as power-supply cord or plug is damaged, liquid has been spilled or objects have fallen into the apparatus, the apparatus has been exposed to rain or moisture, does not operate normally, or has been dropped.
15. Damage Requiring Service  
Unplug the apparatus from the wall outlet and refer servicing to qualified service personnel under the following conditions:
  - A. When the power-supply cord or plug is damaged,
  - B. If liquid has been spilled, or objects have fallen into the apparatus,
  - C. If the apparatus has been exposed to rain or water,
  - D. If the apparatus does not operate normally by following the operating instructions. Adjust only those controls that are covered by the operating instructions as an improper adjustment of other controls may result in damage and will often require extensive work by a qualified technician to restore the apparatus to its normal operation,
  - E. If the apparatus has been dropped or damaged in any way, and
  - F. When the apparatus exhibits a distinct change in performance this indicates a need for service.
16. Object and Liquid Entry  
Never push objects of any kind into the apparatus through openings as they may touch dangerous voltage points or short-out parts that could result in a fire or electric shock.  
The apparatus shall not be exposed to dripping or splashing and no objects filled with liquids, such as vases shall be placed on the apparatus.  
Don't put candles or other burning objects on top of this unit.
17. Batteries  
Always consider the environmental issues and follow local regulations when disposing of batteries.
18. If you install the apparatus in a built-in installation, such as a bookcase or rack, ensure that there is adequate ventilation.  
Leave 20 cm (8") of free space at the top and sides and 10 cm (4") at the rear. The rear edge of the shelf or board above the apparatus shall be set 10 cm (4") away from the rear panel or wall, creating a flue-like gap for warm air to escape.

# Precautions

---

## **DANGER:**

VISIBLE AND INVISIBLE LASER RADIATION WHEN OPEN AND INTERLOCK FAILED OR DEFEATED. DO NOT STARE INTO BEAM.

## **CAUTION:**

THIS PRODUCT UTILIZES A LASER. USE OF CONTROLS OR ADJUSTMENTS OR PERFORMANCE OF PROCEDURES OTHER THAN THOSE SPECIFIED HEREIN MAY RESULT IN HAZARDOUS RADIATION EXPOSURE.

This unit contains a semiconductor laser system and is classified as a "CLASS 1 LASER PRODUCT." So, to use this model properly, read this Instruction Manual carefully. In case of any trouble, please contact the store where you purchased the unit. To prevent exposure to the laser beam, do not try to open the enclosure.

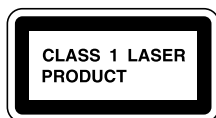

In some cases, this label is located on the rear panel. It indicates that:

1. This unit is a CLASS 1 LASER PRODUCT and employs a laser inside the cabinet.
2. To prevent the laser from being exposed, do not remove the cover. Refer servicing to qualified personnel.

## **For U.S. model**

The laser is covered by a housing which prevents exposure during operation or maintenance. However, this product is classified as a Laser Product by CDRH (Center for Devices and Radiological Health) which is a department of the Food and Drug Administration.

According to their regulations 21 CFR section 1002.30, all manufacturers who sell Laser Products must maintain records of written communications between the manufacturer, dealers and customers concerning radiation safety. If you have any complaints about instructions or explanations affecting the use of this product, please feel free to write to the address on the back page of this manual. When you write us, please include the model number and serial number of your unit.

In compliance with Federal Regulations, the certification, identification and the period of manufacture are indicated on the rear panel.

## **FCC INFORMATION FOR USER**

### **CAUTION:**

The user changes or modifications not expressly approved by the party responsible for compliance could void the user's authority to operate the equipment.

### **NOTE:**

This equipment has been tested and found to comply with the limits for a Class B digital device, pursuant to Part 15 of the FCC Rules. These limits are designed to provide reasonable protection against harmful interference in a residential installation. This equipment generates, uses and can radiate radio frequency energy and, if not installed and used in accordance with the instructions, may cause harmful interference to radio communications. However, there is no guarantee that interference will not occur in a particular installation. If this equipment does cause harmful interference to radio or television reception, which can be determined by turning the equipment off and on, the user is encouraged to try to correct the interference by one or more of the following measures:

- Reorient or relocate the receiving antenna.
- Increase the separation between the equipment and receiver.
- Connect the equipment into an outlet on a circuit different from that to which the receiver is connected.
- Consult the dealer or an experienced radio/TV technician for help.

## **For Canadian model**

For models having a power cord with a polarized plug:

**CAUTION:** TO PREVENT ELECTRIC SHOCK, MATCH WIDE BLADE OF PLUG TO WIDE SLOT, FULLY INSERT.

**NOTE:** This Class B digital apparatus complies with Canadian ICES-003.

## **Modèle canadien**

Sur les modèles dont la fiche est polarisée:

**ATTENTION:** POUR ÉVITER LES CHOCS ÉLECTRIQUES, INTRODUIRE LA LAME LA PLUS LARGE DE LA FICHE DANS LA BORNE CORRESPONDANTE DE LA PRISE ET POUSSER JUSQU'AU FOND.

**REMARQUE:** CET APPAREIL NUMÉRIQUE DE LA CLASSE B EST CONFORME À LA NORME NMB-003 DU CANADA.

### 1. Region Numbers

The DVD standard uses region numbers to control how discs can be played around the world, the world being divided into six regions. This unit will only play DVD discs that match its region number, which can be found on its rear panel (e.g., .

### 2. About this Manual

This manual explains how to use all of this unit's functions. Although the DVD standard offers many special features, not all discs use them all, so depending on the disc being played, this unit may not respond to certain functions. See the disc's sleeve notes for supported features.

When you attempt to use a DVD feature that is not available, this logo may appear onscreen, indicating that the feature is not supported by the current disc or this unit.



### 3. Warranty

If you need to use the warranty, please provide the serial number printed on this unit's rear panel.

### 4. Recording Copyright

Unless it's for personal use only, recording copyrighted material is illegal without the permission of the copyright holder.

### 5. Power

#### WARNING

BEFORE PLUGGING IN THE UNIT FOR THE FIRST TIME, READ THE FOLLOWING SECTION CAREFULLY.

AC outlet voltages vary from country to country. Make sure that the voltage in your area meets the voltage requirements printed on this unit's rear panel (e.g., AC 120 V, 60 Hz).

### 6. Never Touch this Unit with Wet Hands

Never handle this unit or its power cord while your hands are wet or damp. If water or any other liquid gets inside this unit, have it checked by your Onkyo dealer.

### 7. Installing this Unit

- Install this unit in a well-ventilated location. Ensure that there's adequate ventilation all around this unit, especially if it's installed in an audio rack. If the ventilation is inadequate, the unit may overheat, leading to malfunction.
- Do not expose this unit to direct sunlight or heat sources, because its internal temperature may rise, shortening the life of the optical pickup.
- Avoid damp and dusty places, and places subject to vibrations from loudspeakers. Never put the unit on top of, or directly above a loudspeaker.
- Install this unit horizontally. Never use it on its side or on a sloping surface, because it may cause a malfunction.
- If you install this unit near a TV, radio, or VCR, the picture and sound quality may be affected. If this occurs, move this unit away from the TV, radio, or VCR.

### 8. Care

Occasionally, you should dust this unit all over with a soft cloth. For stubborn stains, use a soft cloth dampened with a weak solution of mild detergent and water. Dry the unit immediately afterwards with a clean cloth. Do not use abrasive cloths, thinners, alcohol, or other chemical solvents, because they may damage the finish or remove the panel lettering.

### 9. Handling Notes

- If you need to transport this unit, use the original packaging to pack it how it was when you originally bought it.
- Do not use volatile liquids, such as insect sprays, near this unit. Do not leave rubber or plastic items on this unit for a long time, because they may leave marks on the case.
- This unit's top and rear panels may get warm after prolonged use. This is normal.
- When you've finished using this unit, remove all discs and turn off the power.
- If you do not use this unit for a long time, it may not work properly the next time you turn it on, so be sure to use it occasionally.

### 10. To Obtain a Clear Picture

This unit is a high-tech, precision device. If the lens on the optical pickup, or the disc drive mechanism becomes dirty or worn, the picture quality may be affected. To maintain the best picture quality, we recommend regular inspection and maintenance (cleaning or worn part replacement) every 1,000 hours of use depending on the operating environment. Contact your Onkyo dealer for details.

### 11. Moisture Condensation

**Moisture condensation may damage this unit.**

**Read the following carefully:**

- When you take a glass containing a cold drink outside on a summer's day, drops of water, called condensation, form on the outside of the glass. Similarly, moisture may condense on the lens of the optical pickup, one of the most important parts inside this unit.
- Moisture condensation can occur in the following situations:
    - The unit is moved from a cold place to a warm place.
    - A heater is turned on, or cold air from an air conditioner is hitting the unit.
    - In the summer, when this unit is moved from an air conditioned room to a hot and humid place.
    - The unit is used in a humid place.
  - Do not use this unit when there's the possibility of moisture condensation occurring. Doing so may damage your discs and certain parts inside this unit. If condensation does occur, remove all discs and leave this unit turned on for two to three hours. By this time, the unit will have warmed up and any condensation will have evaporated. To reduce the risk of condensation, keep this unit connected to a wall outlet.

# Introduction

## Supplied Accessories

Make sure you have the following accessories:

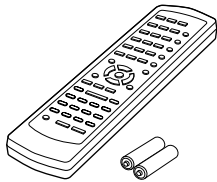

**RC-542DV remote controller & two AA-size batteries**

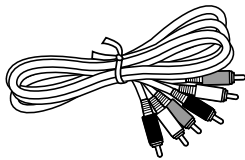

**AV connecting cable (5 ft.)**



**S-Video connecting cable (5 ft.)**

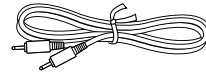

**RI cable (2.6 ft.)**

This cable is used to connect the DVD player to other **RI**-compatible Onkyo components for **RI** (Remote Interactive) control.

To use **RI**, in addition to an **RI** connection, you must make an analog audio connection (RCA) between the DVD player and your Onkyo AV receiver.

## DV-CP802 Features

### Highlights

- Dolby<sup>\*1</sup> Digital and DTS<sup>\*2</sup>
- DVD-Video, DVD-Audio, and SACD universal player
- Progressive scanning
- Holds up to six discs
- Chain mode for successive disc playback
- VCD, CD, and MP3 playback
- JPEG picture display and slideshow
- CD-R, CD-RW (VCD, CD, MP3, JPEG)
- DVD-R, DVD-RW (DVD-Video, DVD-VR)
- VLSC—Vector Linear Shaping Circuitry<sup>\*3</sup>

### Video

- Advanced 108 MHz/12-bit video D/A converter
- Component video output
- S-Video and composite video outputs

### Audio

- Audiophile-class performance
- Direct Digital Path
- 192 kHz/24-bit D/A converter
- 5.1-channel analog audio output
- Coaxial digital output
- Optical digital output

### Others

- Search options include, title, chapter (DVD-Video), group (DVD-Audio), track (DVD-Audio, SACD, CD, VCD) and time
- Frame-by-frame playback
- Slow-motion playback
- Fast forward and reverse
- Last Memory function allows you to resume playback from a specific point on a DVD or VCD, even if that disc has been removed from the DV-CP802
- Repeat playback options include, title, chapter (DVD-Video), track (DVD-Audio, SACD, CD, VCD, MP3, JPEG), folder (MP3, JPEG), and All Disc and 1 Disc (all disc formats)
- Random playback options include, title (DVD-Video), group (DVD-Audio), folder (MP3, JPEG), and All Disc and 1 Disc (all disc formats)
- Supports 4:3 and 16:9 aspect ratio TVs
- Multiple camera angle support
- Parental Lock function
- Screen Saver function
- Load discs without stopping playback
- Dynamic Range Control setting
- Adjustable display brightness

\* In catalogs and on packaging, the letter added to the end of the product name indicates the color of the DV-CP802. Specifications and operation are the same regardless of color.

\*1. Manufactured under license from Dolby Laboratories. Dolby, Pro Logic, and the double-D symbol are registered trademarks of Dolby Laboratories.

\*2. DTS and DTS Digital Surround are trademarks of Digital Theater Systems, Inc.

\*3. VLSC is a trademark of Onkyo Corporation.

## Disc Notes

### Supported Discs

The DV-CP802 supports the following discs.

Disc	Logo	Format or file type
DVD-Video		DVD-Video
DVD-Audio		DVD-Audio
SACD		Super Audio CD (single layer, dual layer, hybrid)
DVD-R		DVD-Video
DVD-RW		DVD-Video, DVD-VR
VCD		Video CD (Version 1.1 and 2.0)
CD		Audio CD (PCM and DTS)
CD-R		Video CD, audio CD, MP3, JPEG
CD-RW		Video CD, audio CD, MP3, JPEG
JPEG CD		JPEG

- The DV-CP802 will play only Region 1 NTSC DVD-Video discs.
- Some audio CDs feature copy protection that doesn't conform to the official CD standard. Since these are nonstandard discs, they may not play properly on the DV-CP802.
- The DV-CP802 supports CD-R and CD-RW discs recorded in Video CD format, audio CD format, or ISO9660 Level 2 format with MP3 and JPEG files. It also supports DVD-R and DVD-RW discs recorded in DVD-Video or DVD-Audio format. However, some CD-R/RW and DVD-R/RW discs may not work properly for any of the following reasons: incomplete disc finalization, disc burner characteristics, disc characteristics, the disc is damaged or dirty. See the manual supplied with your disc burner for more information. Condensation or dirt on the optical pickup lens can also affect playback.
- The DV-CP802 cannot play DVD-VR discs recorded with *Copy Once* permission.
- The DV-CP802 does not support disc types not listed.
- The DV-CP802 supports 8 cm and 12 cm discs.
- Don't use discs with an unusual shape, such as those shown below, because you may damage the DV-CP802.



- Don't use discs that have residue from adhesive tape, rental discs with peeling labels, or discs with custom-made labels or stickers. Doing so may damage the DV-CP802 and you may not be able to remove the disc properly.

### DVD Region Numbers









The DV-CP802 supports only Region 1 DVD-Video discs bearing this logo.



If you attempt to play a disc intended for another region, a message saying that the disc cannot be played appears. Discs marked *ALL* will play in any DVD player.

### Function Support

The following icons are used throughout this manual to indicate which discs can be used with each function.

Icon	Disc type	Icon	Disc type
	DVD-Video		Video CD
	DVD-Audio		Audio CD
	Super Audio CD		MP3
	DVD-VR		JPEG

### Unsupported DVD Features

The DVD standard offers many special features, including multiple soundtracks, subtitles, camera angles, and so on. However, not all discs use all of these features. When you attempt to use a feature that is not used by the current disc, for example, you press the remote controller's [AUDIO] button while playing a disc with only one soundtrack, this icon will appear onscreen, indicating that the feature is not supported by the current disc.



Similarly, if a disc uses features that are not supported by the DV-CP802, for example, special interactive menu functions, this icon will appear onscreen, indicating that the feature is not supported by the DV-CP802.



### Video CDs

The DV-CP802 supports Version 1.1 and Version 2.0 of the Video CD standard. Version 2.0 supports PBC (Playback Control).

- **Video CD (Version 1.1)**  
On the DV-CP802, the contents of Video CDs that conform to Version 1.1 of the Video CD standard are handled as tracks.
- **Video CD with PBC (Version 2.0)**  
In addition to the functions supported by Version 1.1, Version 2.0 offers playback control via interactive menus and search functions. Note that the DV-CP802 doesn't support all PBC functions.

### Disc Content Organization

#### ■ DVD-Video

DVD-Video discs typically contain one or more titles, which may be subdivided into chapters.

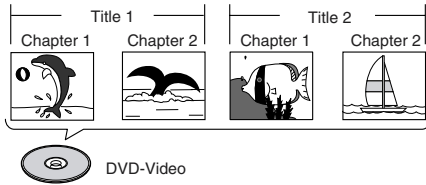

#### ■ DVD-Audio

DVD-Audio discs contain groups and tracks.

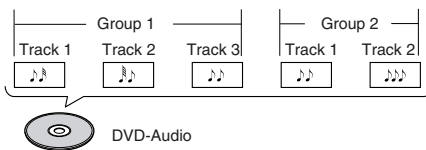

#### ■ SACD

SACDs have two separate areas for storing audio tracks—one for multichannel audio, the other for 2-channel stereo audio. In addition, hybrid SACDs have an extra layer for playback in standard CD players. You can specify how the DV-CP802 plays SACDs on page 55.

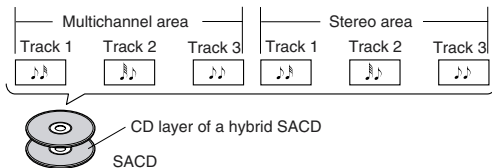

#### ■ VCD

VCDs contain tracks.

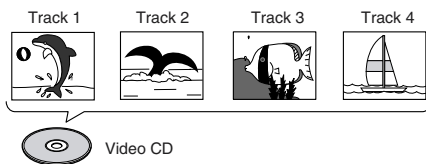

#### ■ CD

CDs contain tracks.

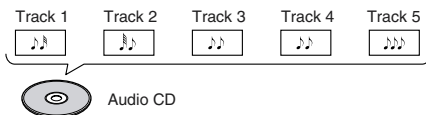

#### ■ MP3

MP3 discs contain MP3 tracks organized into folders.

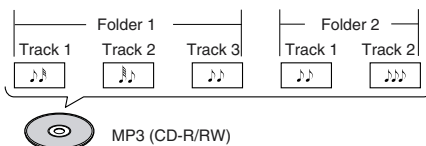

#### ■ JPEG

JPEG discs contain pictures organized into folders. The DV-CP802 handles JPEG files as tracks.

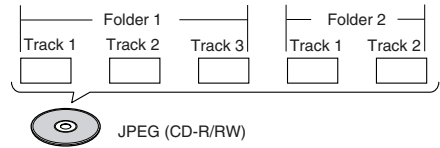

### MP3 & JPEG Compatibility

- The DV-CP802 can play/display MP3 and JPEG files recorded on CD-R and CD-RW discs.
- Discs must be in ISO9660 Level 2 format (folders can be up to eight levels deep).
- Discs must be finalized.
- The DV-CP802 can only recognize the first session on multisession discs.
- You can determine the order in which the DV-CP802 plays/displays your MP3 songs and JPEG pictures by prefixing file and folder names with a three-digit number. For example 001.Root, 002.Folder, and so on, and 001.Track.mp3, 002.Track.mp3, and so on.
- Only the first eight characters of folder and track names (excluding the filename extension) are displayed.
- The folder numbered “001” appears as “ROOT” in the Disc Navigator.
- The DV-CP802 supports up to 999 folders and up to 672 files per folder.
- If you try to play an incompatible file, the message “This format cannot be played” appears on the display.

#### ■ MP3

- MP3 files must be MPEG1 Audio Layer 3 format, 44.1 or 48 kHz, fixed bit-rate.
- MP3 files must have a “.mp3” or “.MP3” filename extension.
- Variable bit-rates (VBR) from 64 kbps to 384 kbps are supported. (Playing times may display incorrectly with VBR.)

#### ■ JPEG

- JPEG files must have a “.jpg” or “.jpeg” filename extension (either uppercase or lowercase is OK).
- Baseline JPEG files are supported. Progressive JPEG files are not.
- Only JPEG files with the following brightness/color difference ratios are supported: 4:4:4, 4:2:2, and 4:1:1.
- JPEG files must be less than 5 megabytes in size.



### Handling Discs

- Never touch the underside of a disc. Always hold discs by the edge, as shown.

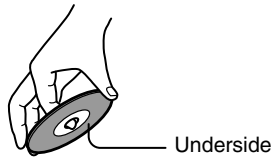

- Never attach adhesive tape or sticky labels to discs.



### Cleaning Discs

- For best results, keep your discs clean. Fingerprints and dust can affect the sound or picture quality and should be removed as follows. Using a clean soft cloth, wipe from the center outwards, as shown. Never wipe in a circular direction.



- To remove stubborn dust or dirt, wipe the disc with a damp soft cloth, and then dry it with a dry cloth.
- Never use solvent-based cleaning fluids, such as thinner or benzene, commercially available cleaners, or antistatic sprays intended for vinyl records, because they may damage the disc.

### Storing Discs

- Don't store discs in places subject to direct sunlight, or near heat sources.
- Don't store discs in places subject to moisture or dust, such as in a bathroom or near a humidifier.
- Always store discs in their cases and vertically. Stacking, or putting objects on unprotected discs may cause warping, scratches, or other damage.

### Copyright

It is forbidden by law to copy, broadcast, show, broadcast on cable, play in public, or rent copyrighted material without permission.

DVD-Video discs are copy-protected, and any recordings made from these discs will be distorted.

This product incorporates copyright protection technology that is protected by U.S. patents and other intellectual property rights. Use of this copyright protection technology must be authorized by Macrovision, and is intended for home and other limited viewing uses only unless otherwise authorized by Macrovision. Reverse engineering or disassembly is prohibited.

### Terminology

■ **CD-R (compact disc recordable):** A type of CD that can be recorded only once. Can be used for VCD, CD, MP3, or JPEG.

■ **CD-RW (compact disc rewritable):** A type of CD that can be recorded over and over again. Can be used for VCD, CD, MP3, or JPEG.

■ **Chapter:** Titles on DVD-Video discs can be subdivided into chapters.

■ **Component video:** A video connection format that separates the luminance (Y) and color difference signals (PR, PB), providing better picture quality than S-Video.

■ **Composite video:** A video connection format that combines the luminance and color signals together.

■ **Direct Digital Path:** Unique Onkyo technology that uses dedicated shielded cables to connect the digital audio outputs, protecting the digital output signals against the possibility of noise and interference.

■ **Dolby Digital:** Once known as AC-3, this is the designated surround sound format for DVD-Video, HDTV, and select digital broadcasts (cable, satellite, over-the-air). A Dolby Digital bitstream may contain mono, stereo, Dolby Surround, or 5.1-channel audio information.

■ **Dolby Pro Logic:** The decoders used in home theater equipment to decode Dolby Surround material. *See* Dolby Surround.

■ **Dolby Surround:** The original Dolby surround-sound format uses matrix encoding to deliver four channels (left, right, center, and surround) over two audio channels. Can be used with VHS video, analog TV, and other analog stereo systems. The movie theater version is known as *Dolby Stereo*.

■ **Downmixing:** The process of mixing multiple audio channels into fewer channels. For example, a 5.1-channel surround mix can be downmixed into two channels for reproduction on stereo systems.

■ **Downsampling:** The process of reducing the sampling rate of digital audio.

■ **DTS (Digital Theater Systems):** Like Dolby Digital, the DTS surround-sound format offers up to 5.1-channels of information, but uses less compression for a more faithful sound.

■ **DVD-Audio:** The DVD format for storing up to six (5.1) channels of 24-bit/96 kHz digital audio or two channels of 24-bit/192 kHz digital audio.

■ **DVD-R (DVD recordable):** A type of DVD disc that can be recorded only once. Can be used for DVD-Video or DVD-Audio.

- **DVD-RW (DVD rewritable):** A type of DVD disc that can be recorded over and over again. Can be used for DVD-Video or DVD-Audio.
- **DVD-Video:** The format for storing MPEG2 video on DVD, with interactive menus, multiple soundtracks, subtitles, camera angles, and so on.
- **Field:** In interlaced scanning, a field is a single scan of the screen. There are two fields per frame. *See* Interlaced Scanning *and* Progressive Scanning.
- **Frame:** An individual TV picture is called a frame. With the NTSC color system there are 30 frames per second.
- **Interlaced scanning:** TV pictures are made by scanning the screen in horizontal lines from top to bottom. With Interlaced scanning, two scans (*fields*) are used to make each picture (*frame*). *Contrast with* Progressive scanning.
- **JPEG (Joint Photographic Experts Group):** The acronym commonly used to refer to the compressed file format used to store digital images.
- **LFE (low-frequency effects):** The surround-sound channel used for low-frequency effects.
- **Linear PCM:** The uncompressed digital audio format used for audio CDs. PCM stands for *Pulse Code Modulation*.
- **MP3 (MPEG 1 Audio Layer 3):** Popular compressed file format for storing digital music.
- **MPEG1 (Moving Picture Experts Group 1):** The compressed digital video format used for VCDs.
- **MPEG2 (Moving Picture Experts Group 2):** The compressed digital video format used for DVDs, offering better picture quality than MPEG1.
- **NTSC:** The color TV system used in the United States, Japan, Taiwan, and Korea.
- **PAL:** The color TV system used in most of Europe, the United Kingdom, Australia, Brazil, and China.
- **PBC (Playback Control):** Version 2.0 of the VCD standard supports interactive menus and search functions.
- **Progressive scanning:** TV pictures are made by scanning the screen in horizontal lines from top to bottom. With progressive scanning, each picture (*frame*) is made by scanning the entire screen in one go, resulting in a clearer and stabler picture. *Contrast with* Interlaced scanning.
- **S-Video:** A video connection format that separates the luminance (Y) and color (C) signals, providing better picture quality than composite video.
- **SACD (Super Audio CD):** SACD uses Direct Stream Digital (DSD) technology for audio performance superior to that of standard CDs. It also supports multi-channel audio, and hybrid discs can be played in standard CD players.
- **Title:** The contents of DVD-Video discs are organized into titles.
- **VCD (Video CD):** The format for storing MPEG1 video on CD.
- **VLSC (Vector Linear Shaping Circuitry):** Unique Onkyo circuitry that reduces pulse noise in analog audio signals converted from digital sources.

# Getting to Know the DV-CP802

## Front Panel

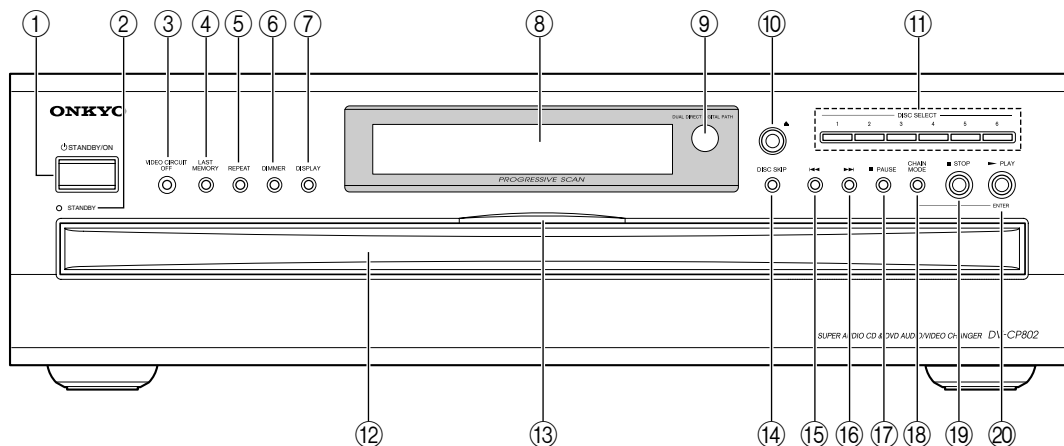

For detailed information, refer to the pages in parenthesis.

### ① **STANDBY/ON button (21)**

This button is used to set the DV-CP802 to On or Standby.

Don't turn on the power until you've completed and double checked all of your connections (page 17).

### ② **STANDBY indicator (21)**

This indicator lights up when the DV-CP802 is in Standby mode.

### ③ **VIDEO CIRCUIT OFF button & indicator (45)**

This button is used to turn off all of the internal video circuitry, eliminating the possibility of interference when playing audio-only discs. The button lights up when the video circuitry is turned off.

### ④ **LAST MEMORY button (42)**

This button is used with the Last Memory function.

### ⑤ **REPEAT button (35)**

This button is used with the Repeat function.

### ⑥ **DIMMER button (32)**

This button is used to adjust the display brightness.

### ⑦ **DISPLAY button (42)**

This button is used to display information about the current disc, title, chapter, or track, including the elapsed time, remaining time, total time, and so on.

### ⑧ **Display**

See "Display" on page 12 for more information.

### ⑨ **Remote control sensor (16)**

This sensor receives control signals from the remote controller.

### ⑩ **Open/Close [▲] button (23)**

This button is used to open and close the disc tray.

### ⑪ **DISC SELECT 1–6 buttons (24)**

These buttons are used to select discs. Playback starts automatically when discs are selected with these buttons

### ⑫ **Disc tray (23)**

The disc tray has six bays for loading up to six discs.

### ⑬ **Disc tray light**

This light illuminates the disc tray. It comes on when the DV-CP802 is turned on, and is brighter while the disc tray is open.

### ⑭ **DISC SKIP button (23, 24)**

This button is used to select the disc bays (i.e., rotate the disc tray) when loading or removing discs, and to select discs for playback.

### ⑮ **Previous [◀◀] button (27, 30)**

This button is used to select the previous chapter or track. During playback it selects the beginning of the current chapter or track.

### ⑯ **Next [▶▶] button (27, 30)**

This button is used to select the next chapter or track.

### ⑰ **PAUSE [■] button (25)**

This button is used to pause playback.

### ⑱ **CHAIN MODE button (34)**

This button is used with the Chain mode function.

### ⑲ **STOP [■] button (25)**

This button is used to stop playback.

### ⑳ **PLAY/ENTER [▶] button (25)**

This button is used to start playback and to cancel fast forward and fast reverse. It's also used to start Chain mode playback.

Display

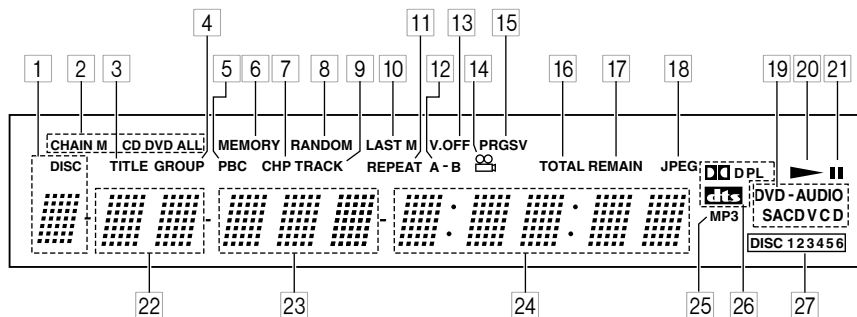





For detailed information, refer to the pages in parenthesis.

- 1 **DISC indicator (24)**  
The number of the currently selected disc appears here.
- 2 **CHAIN M, CD, DVD & ALL indicators (34)**  
Short for CHAIN MODE, the CHAIN M indicator appears when the Chain mode function is on. The CD, DVD, and ALL indicators show the type of Chain mode selected.
- 3 **TITLE indicator**  
This indicator appears while title numbers are being displayed. While stopped, the total number of titles on the current DVD-Video disc is displayed here. During playback, the number of the current title is displayed.
- 4 **GROUP indicator**  
This indicator appears while group numbers are being displayed. While stopped, the total number of groups on the current DVD-Audio disc are displayed. During playback, the number of the current group is displayed.
- 5 **PBC indicator**  
This indicator appears if the VCD currently playing supports PBC (Playback Control).
- 6 **MEMORY indicator**  
This indicator appears when using the Memory function.
- 7 **CHP indicator**  
This indicator appears while the number of the current chapter is being displayed.
- 8 **RANDOM indicator (37)**  
This indicator appears when using the Random function.
- 9 **TRACK indicator**  
This indicator appears while track numbers are being displayed. While stopped, the total number of tracks on the current VCD, CD, or MP3 disc are displayed.

- 10 **LAST M indicator (42)**  
This indicator appears when using the Last Memory function.
- 11 **REPEAT indicator (35)**  
This indicator appears when using the Repeat function.
- 12 **A-B indicators (36)**  
These indicators appear when using the A-B Repeat function.
- 13 **V. OFF indicator (45)**  
This indicator appears while the video circuits are turned off.
- 14 **Camera angle indicator (40)**  
This indicator appears if the DVD-Video disc being played features multiple camera angles.
- 15 **PRGSV indicator (41)**  
This indicator appears when progressive scanning is on.
- 16 **TOTAL indicator**  
This indicator appears while the total time is being displayed.
- 17 **REMAIN indicator**  
This indicator appears while the remaining time is being displayed.
- 18 **JPEG indicator**  
This indicator appears while a JPEG picture is being displayed.
- 19 **DVD-AUDIO & SACDVCD indicators**  
These indicators show the type of disc currently selected.  
**DVD:** DVD-Video  
**DVD-AUDIO:** DVD-Audio  
**SACD:** Super Audio CD  
**VCD:** Video CD  
**CD:** Audio CD, MP3, JPEG

- 20 **Play ► indicator (25)**  
This indicator is shown during playback.
- 21 **Pause ■■ indicator (25)**  
This indicator appears when playback is paused.
- 22 **Title & group number**  
Title and group numbers appear here.
- 23 **Chapter & track number**  
Chapter and track numbers appear here.
- 24 **Time display**  
Time information, such as total time, remaining time, and so on, is displayed here in hours, minutes, and seconds. Other messages are also displayed.
- 25 **MP3 indicator**  
This indicator appears while an MP3 track is being played.

- 26 **Dolby Digital (  D), Dolby Pro Logic (  PL) & DTS (  ) indicators**  
The Dolby Digital indicator (  D) appears when a Dolby Digital soundtrack is selected. The Dolby Pro Logic (  PL) indicator appears when the DV-CP802's Dolby Pro Logic decoder is on. The DTS indicator appears when a DTS soundtrack is selected.
- 27 **DISC indicators 1–6 (23)**  
These indicators show how many discs are loaded. When the disc tray is closed, all of the disc indicators appear until the DV-CP802 has checked each bay for the presence of a disc. If a bay is found to have no disc, the corresponding indicator disappears.

## Rear Panel

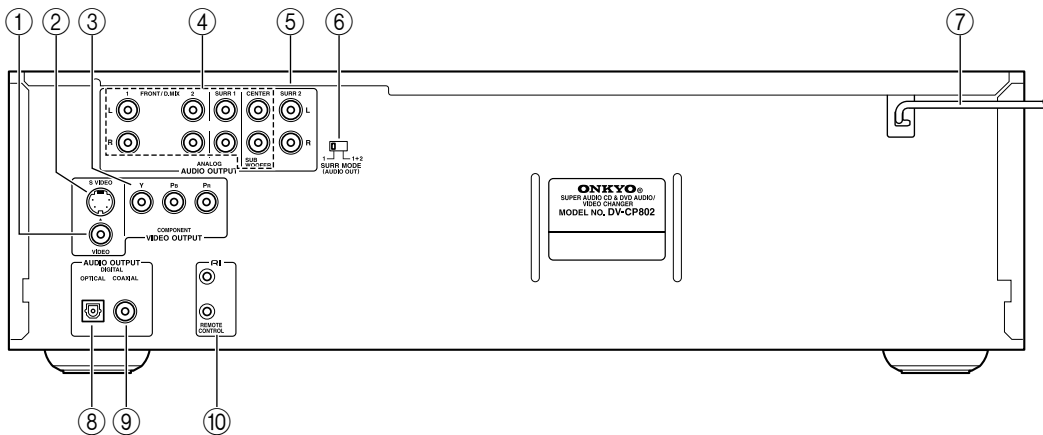

For detailed information, refer to the pages in parenthesis.

- ① **VIDEO OUTPUT (18)**  
This socket outputs composite video and can be connected to a composite video input on a TV or projector.
- ② **S VIDEO OUTPUT (18)**  
This socket outputs S-Video and can be connected to an S-Video input on a TV or projector.
- ③ **COMPONENT VIDEO OUTPUT (18)**  
These sockets output component video and can be connected to a component video input on a TV or projector.
- ④ **FRONT/D.MIX 1 & 2, SURR 1, CENTER & SUBWOOFER AUDIO OUTPUT (19)**  
These sockets output 5.1-channel analog audio and can be connected to a 5.1-channel analog audio input on an AV receiver, surround sound decoder

- (Dolby Pro Logic), or other component. The FRONT/D.MIX 1 & 2 outputs can be used as either front outputs or downmix outputs (see page 52).
- ⑤ **SURR 2 AUDIO OUTPUT (19)**  
These sockets output the same analog audio as the SURR1 outputs and can be connected to the analog surround back left and right inputs on a 7.1-channel AV receiver or other component. When using these sockets, the SURR MODE switch should be set to 1+2.
- ⑥ **SURR MODE (AUDIO OUT) switch (19)**  
This switch is used to set the surround output mode of the analog multichannel audio outputs. If you connect the SURR 2 outputs to a 7.1-channel AV receiver or amp, set this switch to 1+2. This reduces the output level by 3 dB. If you're not using the SURR 2 outputs, set it to 1.

## Getting to Know the DV-CP802—Continued

- ⑦ **Power cord (21)**  
Connect the power cord to a suitable wall outlet.
- ⑧ **OPTICAL DIGITAL AUDIO OUTPUT (20)**  
This optical digital audio output can be connected to an optical digital audio input on a hi-fi amp, AV receiver, or surround sound decoder (Dolby Digital, DTS). The Digital Out/Digital1 setting on page 50 is used to configure this output.
- ⑨ **COAXIAL DIGITAL AUDIO OUTPUT (20)**  
This coaxial digital audio output can be connected to a coaxial digital audio input on a hi-fi amp, AV receiver, or surround sound decoder (Dolby Digital, DTS). The Digital Out/Digital2 setting on page 51 is used to configure this output.

- ⑩ **RI REMOTE CONTROL (20)**  
These **RI** (Remote Interactive) connectors can be connected to the **RI** connectors on your other Onkyo AV components for interactive control. To use **RI** you must make an analog audio connection (RCA) between the DV-CP802 and your Onkyo AV receiver, even if they are connected digitally.

## Remote Controller

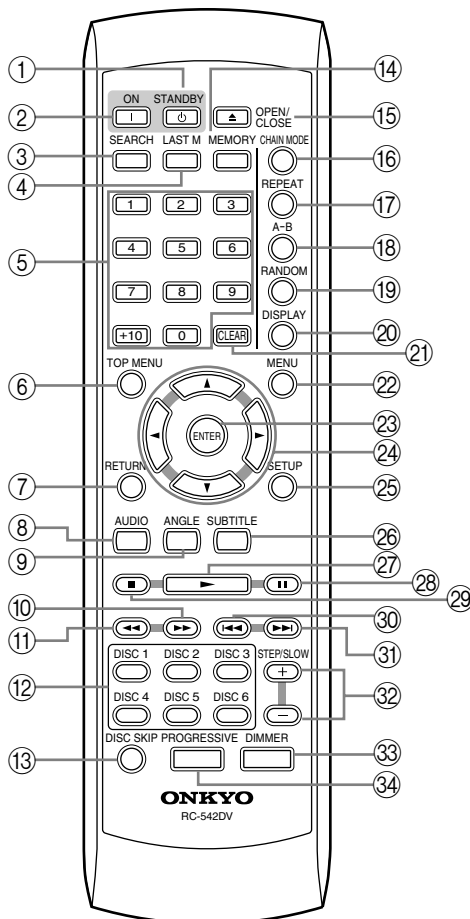

For detailed information, refer to the pages in parenthesis.

- ① **STANDBY button (21)**  
This button is used to set the DV-CP802 to Standby.
- ② **ON button (21)**  
This button is used to turn on the DV-CP802. Don't turn on the DV-CP802 until you've completed and double checked all of your connections (page 17).
- ③ **SEARCH button (27, 30, 35)**  
This button is used to search for titles, chapters, groups, tracks, and specific points in time.
- ④ **LAST M button (42)**  
This button is used with the Last Memory function.
- ⑤ **Number buttons (27, 30, 35)**  
These buttons are used to enter title, chapter, group, and track numbers and to enter times for locating specific points in time. To enter a single-digit number, simply press the corresponding button. To enter a double-digit number, enter the numbers in order from left-to-right (e.g., to enter 14, press [1] then [4]). The [+10] button is used to enter multiples of ten (i.e., 10, 20, 30, and so on). For example, to enter the number 25, press the [+10] button twice followed by the [5] button.
- ⑥ **TOP MENU button (26)**  
This button is used to select the top menu.
- ⑦ **RETURN button (48)**  
This button is used to return to the previously displayed onscreen setup menu.

- ⑧ **AUDIO button (41)**  
This button is used to select foreign language soundtracks and audio formats (e.g., Dolby Digital or DTS). It's also used to select the multichannel area, 2-channel area, or CD layer on SACDs.
- ⑨ **ANGLE button (40)**  
This button is used to select different camera angles.
- ⑩ **Fast Forward [▶▶] button (31)**  
This button is used to start fast forward.
- ⑪ **Fast Reverse [◀◀] button (31)**  
This button is used to start fast reverse.
- ⑫ **DISC 1–6 buttons (24)**  
These buttons are used to select discs. Playback starts automatically when discs are selected with these buttons.
- ⑬ **DISC SKIP button (23, 24)**  
This button is used to select the disc bays (i.e., rotate the disc tray) when loading or removing discs, and to select discs for playback.
- ⑭ **MEMORY button (29, 38)**  
This button is used with the Memory function.
- ⑮ **OPEN/CLOSE [▲] button (23)**  
This button is used to open and close the disc tray.
- ⑯ **CHAIN MODE button (34)**  
This button is used with the Chain mode function.
- ⑰ **REPEAT button (35)**  
This button is used to set the Repeat functions.
- ⑱ **A–B button (36)**  
This button is used to set the A–B Repeat function.
- ⑲ **RANDOM button (37)**  
This button is used with the Random function.
- ⑳ **DISPLAY button (42)**  
This button is used to display information about the current disc, title, chapter, group, or track, including the elapsed time, remaining time, total time, and so on.
- ㉑ **CLEAR button (27, 30, 39)**  
This button is used to cancel functions and to clear entered numbers.
- ㉒ **MENU button (26)**  
This button is used to show DVD menus.
- ㉓ **ENTER button (21)**  
This button is used to start playback of the selected title chapter, group, or track and to confirm settings.
- ㉔ **Arrow [▲], [▼], [◀], [▶] buttons (21)**  
These buttons are used to navigate onscreen menus.
- ㉕ **SETUP button (48)**  
This button is used to open and close the onscreen setup menus.
- ㉖ **SUBTITLE button (41)**  
This button is used to select subtitles.
- ㉗ **Play [▶] button (25)**  
This button is used to start playback.
- ㉘ **Pause [⏸] button (25)**  
This button is used to pause playback.
- ㉙ **Stop [■] button (25)**  
This button is used to stop playback.
- ㉚ **Previous [◀◀] button (27, 30)**  
This button is used to select the previous chapter or track. During playback it selects the beginning of the current chapter or track.
- ㉛ **Next [▶▶] button (27, 30)**  
This button is used to select the next chapter or track.
- ㉜ **STEP/SLOW [+] & [-] buttons (31)**  
These buttons are used for frame-by-frame playback and slow-motion playback.
- ㉝ **DIMMER button (32)**  
This button is used to adjust the display brightness.
- ㉞ **PROGRESSIVE button (41)**  
This button is used to turn on and off progressive scanning. Progressive scanning can't be turned on or off during playback.

# Before Using the DV-CP802

## Installing the Remote's Batteries

- 1 Open the battery compartment, as shown.

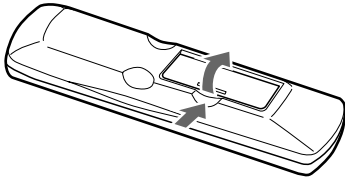

- 2 Insert the two supplied batteries (AA) in accordance with the polarity diagram inside the battery compartment.

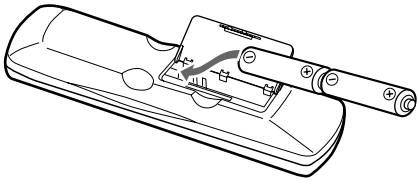

- 3 Close the battery compartment.

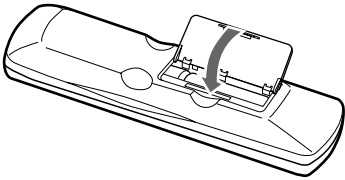

### Notes:

- The supplied batteries should last for about six months, although this will vary with usage.
- If the remote controller doesn't work reliably, try replacing both batteries.
- Don't mix new and old batteries, or different types of batteries.
- If you intend not to use the remote controller for a long time, remove the batteries to prevent possible leakage and corrosion.
- Flat batteries should be removed as soon as possible to prevent possible leakage and corrosion.

## Using the Remote Controller

To use the remote controller, point it at the DV-CP802's remote control sensor, as shown below.

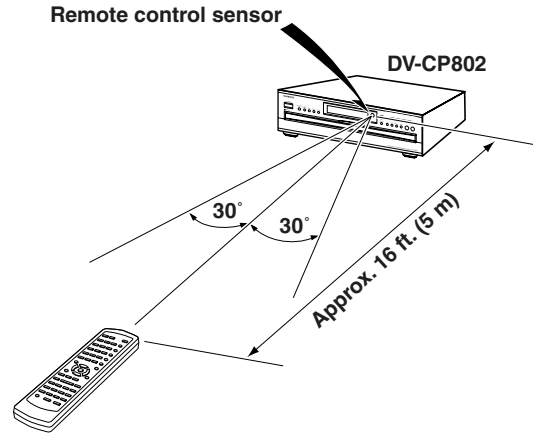

### Notes:

- The remote controller may not work reliably if the DV-CP802 is subjected to bright light, such as direct sunlight or inverter-type fluorescent lights. Keep this in mind when installing the DV-CP802.
- If another remote controller of the same type is used in the same room, or the DV-CP802 is installed close to equipment that uses infrared rays, the remote controller may not work reliably.
- Don't put anything, such as a book, on the remote controller, because the buttons may be pressed inadvertently, thereby draining the batteries.
- The remote controller may not work reliably if the DV-CP802 is installed in a rack behind colored glass doors. Keep this in mind when installing the DV-CP802.
- The remote controller will not work if there's an obstacle between it and the DV-CP802's remote control sensor.



# Connecting the DV-CP802

This chapter explains how to connect the DV-CP802 to your other AV components.

## Before Making Any Connections

- Read the manuals supplied with your AV components.
- Don't connect the power cord until you've completed all audio and video connections.

## Optical Digital Output

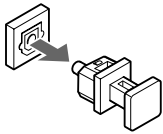

The DV-CP802's optical digital output socket has a dust cap for keeping out dust and dirt when it's not in use. Remove the cap before inserting an optical plug, and push the plug in all the way to make a good connection. Keep the dust cap in a safe place for future use.

## RCA AV Connection Color Coding

RCA-type AV connections are usually color coded: red, white, and yellow. Use red plugs to connect right-channel audio inputs and outputs (typically labeled "R"). Use white plugs to connect left-channel audio inputs and outputs (typically labeled "L"). And use yellow plugs to connect composite video inputs and outputs.



- Push each plug in all the way to make a good connection (loose connections can cause noise or malfunctions).
- To prevent interference, keep audio and video cables away from power cords and speaker cables.

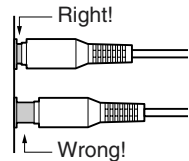

## AV Cables & Connectors

Video			
<b>Component video</b>			Component video separates the luminance (Y) and color difference signals (PR, PB), providing the best picture quality. (Some TV manufacturers label their component video inputs slightly differently.)
<b>S-Video</b>			S-Video provides better picture quality than composite video.
<b>Composite video</b>			Composite video can be found on virtually all TVs, VCRs, and other video equipment. Use only dedicated composite video cables.
Audio			
<b>Optical digital</b>			Optical digital audio connections can carry Dolby Digital or DTS multichannel digital audio (DVD-Video, DVD-Audio) or stereo digital audio (DVD-Video, DVD-Audio, SACD, VCD, CD, MP3).
<b>Coaxial digital</b>			Coaxial digital audio connections can carry Dolby Digital or DTS multichannel digital audio (DVD-Video, DVD-Audio) or stereo digital audio (DVD-Video, DVD-Audio, SACD, VCD, CD, MP3).
<b>Analog</b>			RCA analog audio connectors can be found on virtually all AV components.
<b>Multichannel analog audio cable (RCA)</b>			This cable carries multichannel analog audio and it's typically used to connect DVD players with individual 5.1/7.1-channel analog audio outputs. Several standard analog audio cables can be used instead of a multichannel cable.

## Connecting Your TV or Projector

This section explains how to connect the DV-CP802 to your TV or projector.

The TV handles the audio and video. If your TV has a Dolby Pro Logic decoder built-in, you'll be able to enjoy DVDs and videos that bear the Dolby Surround logo.

To enjoy Dolby Digital or DTS (5.1-channel surround), you'll need a suitable decoder (see page 19).

The DV-CP802 has three types of video output: component video, S-Video, and composite video. Component video offers the best picture quality, so if your TV supports it, use a commercially available component video cable to connect the DV-CP802's COMPONENT video output to the component video input on your TV. If your TV supports progressive scanning, you must use component video in order to take advantage of that feature.

See page 41 for more information on progressive scanning.

S-Video offers better picture quality than composite video, so if your TV supports it, use the supplied S-Video cable to connect the DV-CP802's S VIDEO output to an S-Video input on your TV. Failing that, use the supplied composite video cable to connect the DV-CP802's VIDEO output to a composite video input on your TV.

- 1** Turn off the DV-CP802 and your TV, and disconnect their power cords from the wall outlets.
- 2** Connect the DV-CP802 to your TV as shown.
- 3** When you've completed all connections, see "Turning On the DV-CP802" on page 21.

### Notes

- Before making any connections, turn off the DV-CP802 and your TV and disconnect their power cords from the wall outlets.
- Refer to the connection information supplied with your TV.
- Connect the DV-CP802's video outputs directly to your TV. Don't connect a VCR in between your DV-CP802 and TV. Doing so may result in picture distortion, because of the copy protection system used on DVD-Video discs.

**\* Only one connection required!**  
Choose component video, S-Video, or composite video.

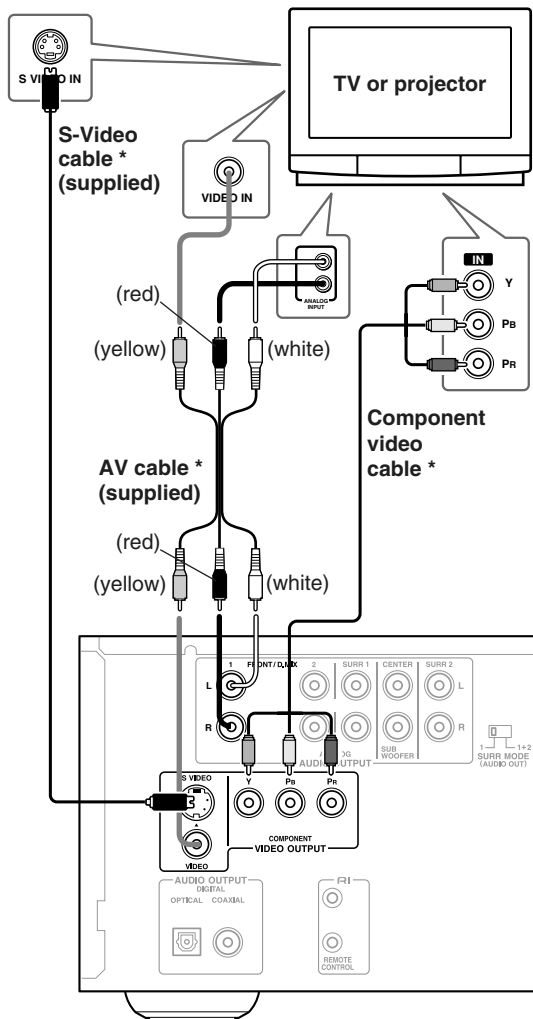

### Compatibility of this unit with progressive-scan and high-definition TVs.

This player is compatible with progressive video Macro Vision System Copy Guard.

CONSUMERS SHOULD NOTE THAT NOT ALL HIGH DEFINITION TELEVISION SETS ARE FULLY COMPATIBLE WITH THIS PRODUCT AND MAY CAUSE ARTIFACTS TO BE DISPLAYED IN THE PICTURE. IN CASE OF 525 PROGRESSIVE SCAN PICTURE PROBLEMS, IT IS RECOMMENDED THAT THE USER SWITCH THE CONNECTION TO THE "STANDARD DEFINITION" OUTPUT. IF THERE ARE QUESTIONS REGARDING OUR TV SET COMPATIBILITY WITH THIS MODEL 525p DVD PLAYER, PLEASE CONTACT OUR CUSTOMER SERVICE CENTER.

## Connecting an AV Receiver

This section shows how to connect the DV-CP802 to an AV receiver for Dolby Digital, DTS, DVD-Audio, and SACD playback.

### Digital Audio Connection (Dolby Digital & DTS)

To fully enjoy the Dolby Digital and DTS soundtracks available on most DVD-Video discs, you need to connect one of the DV-CP802's digital audio outputs (OPTICAL or COAXIAL) to a digital audio input on a Dolby Digital/DTS-compatible AV receiver. You can also enjoy Dolby Surround material, if your AV receiver supports Dolby Pro Logic.

Use an optical (or coaxial) digital audio cable to connect the DV-CP802's OPTICAL (or COAXIAL) DIGITAL AUDIO OUTPUT to an optical (or coaxial) digital audio input on your AV receiver, as shown.

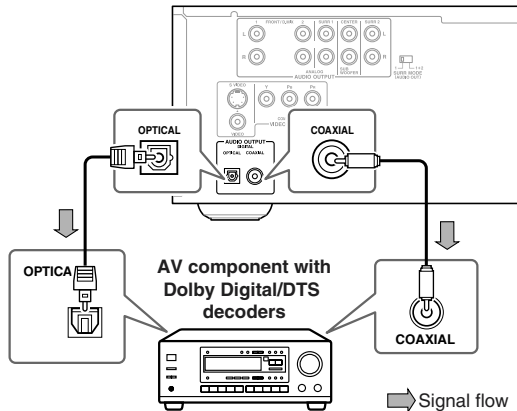

#### Notes:

- Make sure that the Dolby Digital Out setting is set to "Dolby Digital," and that the DTS Out setting is set to DTS (see page 50). Otherwise you won't get surround sound.
- The output formats for the OPTICAL and COAXIAL digital audio outputs can be set independently (see page 50).
- When playing a Dolby Digital or DTS soundtrack, be sure to select Dolby Digital or DTS decoding, respectively, on your AV receiver. On some receivers, the appropriate listening mode is selected automatically. Refer to your AV receiver's manual.
- You can experience Dolby Digital only with DVDs that bear the Dolby Digital logo. Likewise, you can experience DTS only with DVDs or CDs that bear the DTS logo.
- In addition to a digital connection, it's recommended that you also connect the FRONT/D.MIX 1 AUDIO OUTPUT to a spare analog audio input on your AV receiver. This will allow you to record audio to a cassette recorder or CD recorder. If your AV receiver supports Zone 2, you must make an analog audio connection in order to select the DV-CP802 as the input source for Zone 2.

### Analog Audio Connection (Dolby Digital, DTS, DVD-Audio & SACD)

To fully enjoy the multichannel audio of DVD-Audio and SACD, you need to connect the DV-CP802's 5.1-channel analog audio output to a multichannel analog audio input on an AV receiver. Dolby Digital and DTS soundtracks can also be fully enjoyed with this type of connection.

Use a multichannel analog audio cable (RCA) to connect the DV-CP802's FRONT/D.MIX 2, SURR 1, CENTER, and SUBWOOFER AUDIO OUTPUTS to a 5.1-channel analog audio input on your AV receiver. (You can use several separate RCA audio cables instead of a multi-channel cable.) Set the SURR MODE (AUDIO OUT) switch to 1.

If your AV receiver supports 7.1-channels and you're using back surround speakers, connect the DV-CP802's SURR 2 AUDIO OUTPUTS to the AV receiver's surround back left and right inputs as well, and set the SURR MODE (AUDIO OUT) switch to 1+2.

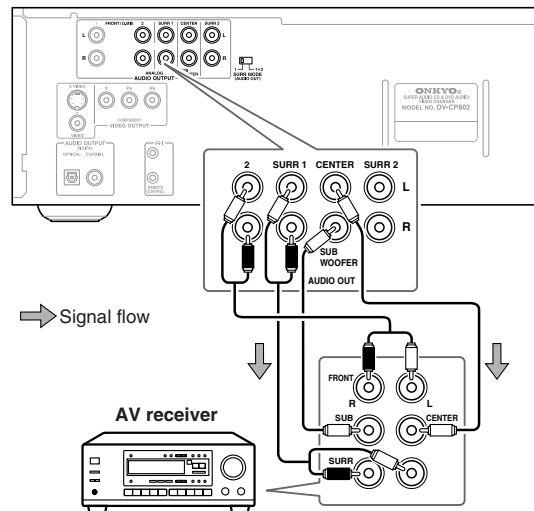

#### Notes:

- Refer to the hookup information supplied with your AV receiver.
- You can experience Dolby Digital only with DVDs that bear the Dolby Digital logo. Likewise, you can experience DTS only with DVDs or CDs that bear the DTS logo.
- DVD-Video discs may contain Dolby Digital and DTS soundtracks. The Dolby Digital soundtrack will be selected by default. To play the DTS soundtrack, use the movie's main menu and look under Language or Audio Setup. Alternatively, use the remote controller's [AUDIO] button (see page 41).
- See "Analog Audio Out" on page 52 for information on how the FRONT/D.MIX 1 and 2 sockets work.

### Connecting a Stereo Amp

This section explains how to connect the DV-CP802 to a stereo amp or receiver for sound quality better than that possible with most TV's built-in speakers. This is great for listening to your CDs and MP3s, and DVDs and VCDs will sound better too. You can also enjoy Dolby Surround, if your amp supports Dolby Pro Logic.

#### Analog Connection

Use an RCA audio cable to connect the DV-CP802's ANALOG AUDIO OUTPUT to a pair of analog audio inputs on your amp or receiver, as shown.

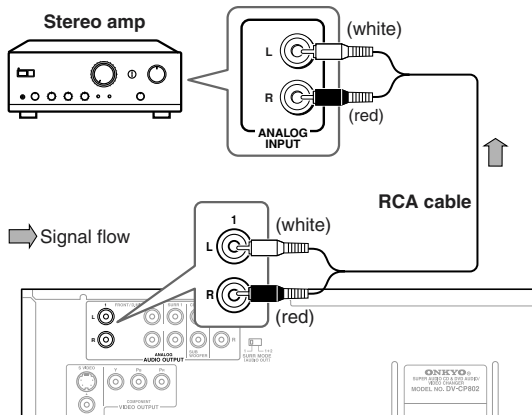

#### Notes:

- Set the Analog Audio Out setting to “2 Channel” (see page 22, 52).
- If your amp has a built-in Dolby Pro Logic decoder, to enjoy DVDs that bear the Dolby Surround logo, set the Analog Audio Out 2 Channel setting to “Lt/Rt” (see page 52).

#### Digital Connection

Use an optical (or coaxial) digital audio cable to connect the DV-CP802's OPTICAL (or COAXIAL) DIGITAL AUDIO OUTPUT to an optical (or coaxial) digital audio input on your amp or receiver, as shown.

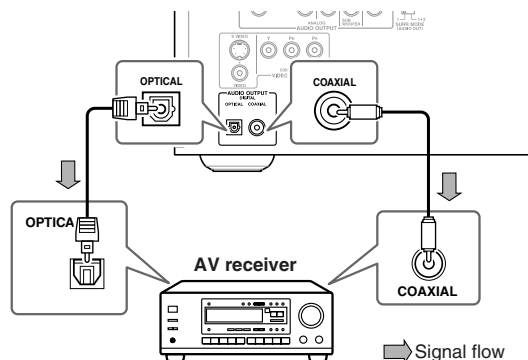

#### Notes:

- Be sure to set the Dolby Digital Out setting to “Dolby Digital>PCM,” and set the DTS Out setting to

“DTS>PCM” (see page 50). Otherwise an unpleasant digital noise may be heard, which may damage your equipment.

- The output formats for the OPTICAL and COAXIAL digital audio outputs can be set independently (see page 50).
- Never connect the DV-CP802 to the AC-3RF input on a Dolby Digital receiver. The AC-3RF format is not supported by the DV-CP802.

### Connecting Components with RI

With **RI** (Remote Interactive) you can control the DV-CP802 by using the remote controller supplied with your Onkyo **RI**-compatible AV receiver.

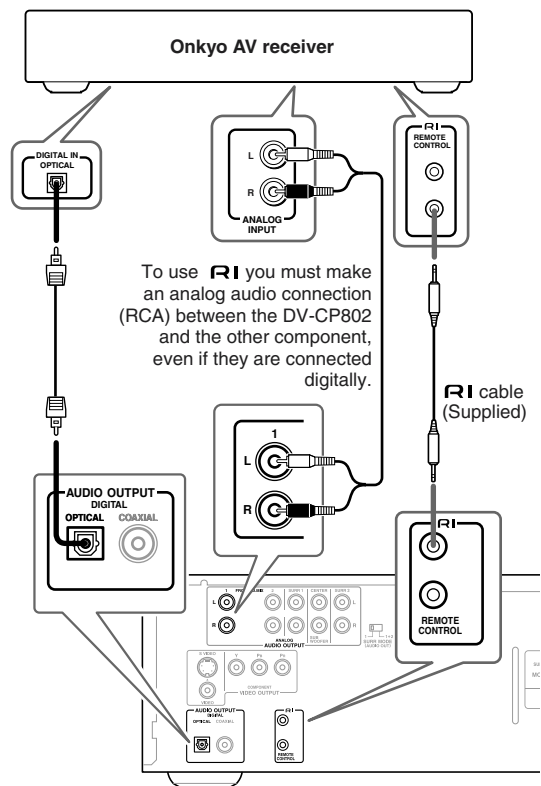

#### Notes:

- Push each plug in all the way to make a good connection.
- Use only **RI** cables for **RI** connections.
- **To use RI you must make an analog audio connection (RCA) between the DV-CP802 and Onkyo AV receiver, even if they are connected digitally.**
- The DV-CP802 has two **RI** sockets. You can connect either one to the Onkyo AV receiver. The other socket is for connecting additional **RI**-compatible components.
- Connect the DV-CP802's **RI** sockets to only Onkyo components. Connecting to other manufacturer's components may cause them to malfunction.

# Turning On the DV-CP802 & First Time Setup

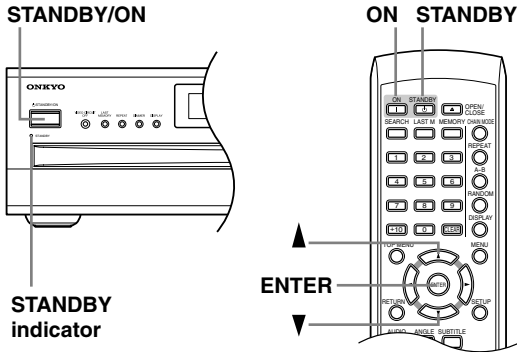

## First Time Setup

The very first time you turn on the DV-CP802, the Initial Setup menu appears onscreen.

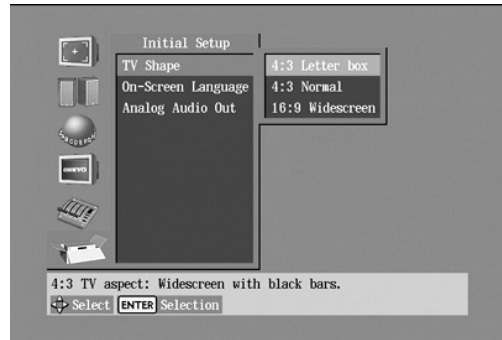

## Turning On the DV-CP802

Before connecting the power cord, connect all of your AV components (see pages 17 to 20).

Don't forget to turn on your TV or projector and select the video input to which the DV-CP802 is connected.

If you're using a hi-fi amp, AV receiver, or surround sound decoder for audio playback, turn that on as well and select the audio input to which the DV-CP802 is connected.

Here you need to make a few settings to get the DV-CP802 up and running. You can change these settings later (see page 46).

**1** **Connect the power cord to a suitable wall outlet.**  
The DV-CP802 enters Standby mode, and the STANDBY indicator comes on.

**2** **To turn on the DV-CP802, press the [STANDBY/ON] button (or the remote controller's [ON] button).**  
The DV-CP802 comes on, the display lights up, and the STANDBY indicator goes off.

To turn off the DV-CP802, press the [STANDBY/ON] button (or the remote controller's [STANDBY] button). The DV-CP802 enters Standby mode and the STANDBY indicator comes on.

**1**  
Remote controller



**Use the Up and Down [▲]/[▼] buttons to select a TV shape, and then press [ENTER].**

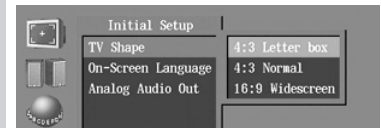

Select 4:3 Letter box or 4:3 Normal if you have a 4:3 TV. Select 16:9 Widescreen if you have a widescreen TV. See page 48 for more information.

The On-Screen Language menu appears.



**2**  
Remote controller



**Use the Up and Down [▲]/[▼] buttons to select a language, and then press [ENTER].**

See page 56 for more information on the language options.

The Analog Audio Out menu appears.

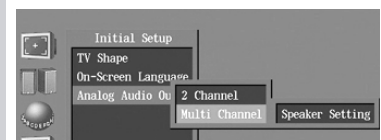

### 3

Remote controller



On the Analog Audio Out menu, use the Up and Down [▲]/[▼] buttons to select 2 Channel or Multi Channel (default), and then press [ENTER].

Choose 2 Channel if you're connecting the FRONT AUDIO OUTs to a stereo amp.

Choose Multi Channel if you're connecting the FRONT, SURR 1/SURR 2, CENTER, and SUBWOOFER AUDIO OUTs to a multichannel amp.

If you select 2 Channel, the setup is complete and the Initial Setup menu closes. If you select Multi Channel, continue with this procedure.

### 4

Remote controller



Press the [ENTER] button, use the Up and Down [▲]/[▼] buttons to select On or Off, and then press the [ENTER] button.

Choose Off if your multichannel amp has its own speaker setup function.

Choose On if your multichannel amp has no speaker setup function.

If you select Off, the following settings cannot be set and the Initial Setup menu closes. If you select On, the Speaker Setting menu appears.



Here you can specify the size of the speakers being fed from the FRONT, SURR 1/SURR 2, CENTER, and SUBWOOFER AUDIO OUTPUTs.

For speakers with a cone diameter larger than 6-1/2 inches (16 cm), specify **Large**. For those with a smaller diameter, specify **Small**. See page 52 for more information.

### 5

Remote controller



Press the [ENTER] button, use the Left and Right [◀]/[▶] buttons to set the Subwoofer setting, and then press [ENTER] again.

**Off:** Select if no subwoofer is being used.

**On (default):** Select if a subwoofer is being used.

### 6

Remote controller

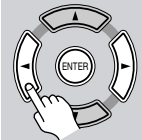

Use the Left and Right [◀]/[▶] buttons to set the Front Speaker setting, and then press the [ENTER] button.

**Large:** Select if the front speakers are large.

**Small (default):** Select if the front speakers are small.

Note that if the Subwoofer setting is set to Off, this setting is fixed at Large.

### 7

Remote controller



Use the Left and Right [◀]/[▶] buttons to set the Center Speaker setting, and then press the [ENTER] button.

**Large:** Select if the center speaker is large.

**Small (default):** Select if the center speaker is small.

**Off:** Select if no center speaker is being used.

Note that if the Front Speaker Size is set to Small, the Large option cannot be selected.

### 8

Remote controller

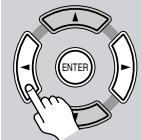

Use the Left and Right [◀]/[▶] buttons to set the Surround Speaker setting, and then press the [ENTER] button.

**Large:** Select if the surround speakers are large.

**Small (default):** Select if the surround speakers are small.

**Off:** Select if no surround speakers are being used.

The Initial Setup menu closes and the setup is complete.

The DV-CP802 is now ready for use. See page 23 for information on loading discs, and page 24 for information on selecting and playing discs.

#### Notes:

- You can change the language of the onscreen setup menus, and your preferred languages for DVD menus, foreign language soundtracks, and subtitles on the Language page of the onscreen setup menu (see page 56).
- When a DVD doesn't have menus, soundtracks, and subtitles in various languages, its default language is used.

# Basic Playback

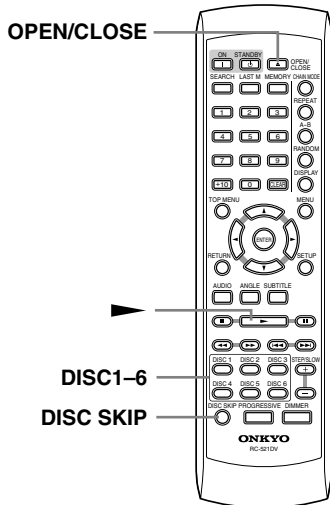
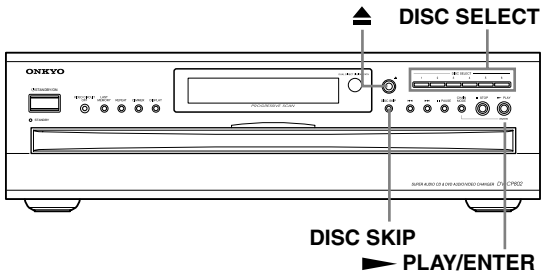

4

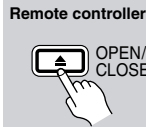

**When you've finished, press the OPEN/CLOSE [▲] button again.**

The disc tray closes.

See page 24 for information on selecting and playing discs.

**Tip:** If you press the Play [▶] button, the disc tray will close and playback of the disc in the right bay will start automatically. If there is no disc in that bay, the DV-CP802 will check the other bays and play the first disc it finds.

**Tip:** If you press one of the DISC SELECT 1–6 buttons, the disc tray will close and playback of the selected disc will start automatically.

## Notes:

- You can load up to six discs. You don't have to load all six discs every time.
- When the disc tray is closed, all of the disc indicators appear until the DV-CP802 has checked each bay for the presence of a disc. If a bay is found to have no disc, the corresponding indicator disappears.
- The disc tray can be opened and closed even while the DV-CP802 is in Standby mode, so you don't have to turn it on to remove your discs. (The disc tray will take slightly longer to open.)
- The DV-CP802 supports 8 cm and 12 cm discs. To avoid damaging your discs or the DV-CP802, always place discs in the center of the disc bays.
- Only load discs that are supported by the DV-CP802 (see page 7). Don't load cartridge-type discs.
- To avoid personal injury, keep your hands away from the disc tray as it closes.
- Always use the OPEN/CLOSE [▲] button to open and close the disc tray. Never push the disc tray, and don't touch it or obstruct it while it's opening or closing. Don't press down on the disc tray while it's open, and don't load anything other than supported discs. Doing so may damage your discs or the DV-CP802.

## Loading Discs



This section explains how to load discs.

1

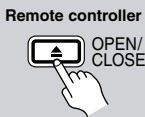

**Press the OPEN/CLOSE [▲] button.**

The disc tray opens and the six disc number indicators appear on the display.

2

**Place a disc, label side up, into each bay.**

3



**Press the [DISC SKIP] button to access the other disc bays.**

The disc tray turns counterclockwise two bays at a time.

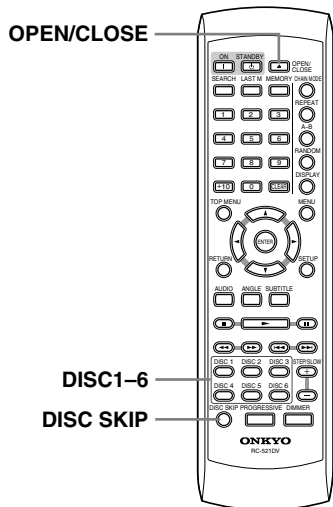
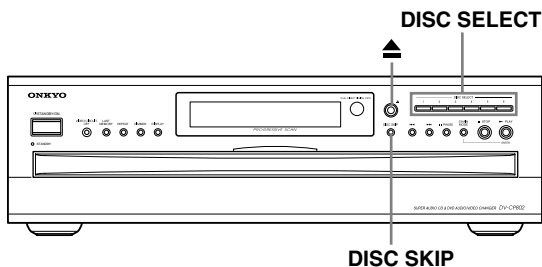

### Loading Discs During Playback



This section explains how to load and remove discs without stopping playback.

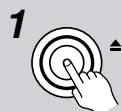

**1 Press the OPEN/CLOSE [▲] button.**

The disc tray opens.

Remote controller



The disc that's currently playing remains inside the DV-CP802 and its disc bay is empty and won't come to the front. To remove this disc you must stop playback before pressing the OPEN/CLOSE [▲] button.

**2**



**Load or remove discs as required, and press the [DISC SKIP] button to access the other disc bays.**

Remote controller



**3**



Remote controller



**When you've finished, press the OPEN/CLOSE [▲] button again.**

The disc tray closes.

Playback of the current disc continues uninterrupted until you either stop playback or select another disc.

**Tip:** If you press one of the DISC SELECT 1–6 buttons, the disc tray will close, playback of the current disc will stop, and playback of the newly selected disc will start automatically.

### Selecting Discs



The section explains how to select loaded discs.

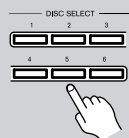

Remote controller

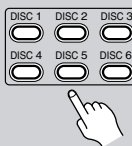

**Use the DISC SELECT 1–6 buttons to select loaded discs.**

On the remote controller these buttons are labelled [DISC 1], [DISC 2], and so on.

The disc indicator on the display shows the number of the current disc.

DVD-Video example is shown here.

Currently selected disc number

Chapter and track number

Type of disc currently selected

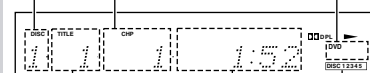

Title and group number

Time display (i.e., total time etc.)

Disc bay number, currently loaded

What happens next depends on the type of disc you selected, as follows:

**DVD-Video:** Typically a menu appears onscreen (see page 26).

**DVD-Audio:** Either playback starts automatically or a menu appears onscreen.

**VCD:** Playback starts automatically.

**DVD-VR/CD/SACD:** Playback starts automatically.

**MP3/JPEG:** The Disc Navigator appears onscreen and playback starts automatically (see page 28).

**JPEG-only CD:** With some JPEG CDs, picture thumbnails appear onscreen (see page 33).



## Basic Playback—Continued

### Notes:

- The type of disc currently selected is shown on the display: DVD, DVD-AUDIO, SACD, VCD, or CD (see page 12).
- You can select discs while the DV-CP802 is stopped or during playback.
- You can use the [DISC SKIP] button to skip the current disc and start the next disc. If disc #6 is the current disc, disc #1 will be selected next.

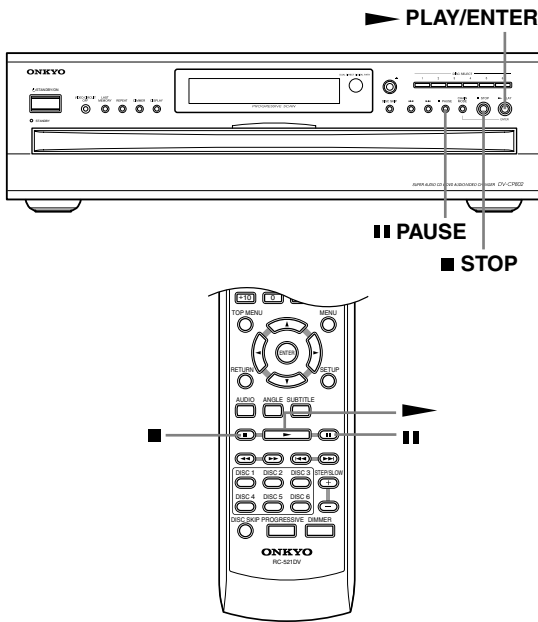

## Starting, Pausing & Stopping Playback

DVD-V DVD-A SACD DVD-VR VCD CD MP3 JPEG

This section explains how to start, pause, and stop playback.

### Start

▶ PLAY



ENTER

Remote controller

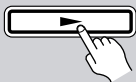

**To start playback, press the Play [▶] button.**

Playback starts and the Play ▶ indicator appears on the display.

If it's a DVD-Video disc, or a VCD with PBC (Playback Control), you may need to start playback from a menu (see page 26).

The front panel Play [▶] button performs play and enter functions. The remote controller has separate Play [▶] and [ENTER] buttons.

### Pause

▬ PAUSE



Remote controller



**To pause playback, press the Pause [▬] button.**

Playback pauses and the Pause ▬ indicator appears on the display.

To resume playback, press the Play [▶] button.

Playback resumes and the Pause ▬ indicator disappears.

### Stop

■ STOP



Remote controller



**To stop playback, press the Stop [■] button.**

Playback stops and the Play ▶ indicator disappears.

### Notes:

- During playback, you can select chapters or tracks by using the Next [▶▶] and Previous [◀◀] buttons. The first press of the Previous [◀◀] button selects the beginning of the current chapter.
- When you stop playback of a DVD disc or VCD, the DV-CP802 remembers the point at which playback was stopped and "Resume" appears onscreen for a few seconds. To resume playback from that point, press the Play [▶] button. To cancel the Resume function, press the Stop [■] button again. The Resume function is reset when another disc is selected.
- With the Last Memory function you can resume playback from a specific point even if another disc has been selected or the disc has been removed (see page 42).
- Do not move the DV-CP802 or subject it to vibration during playback. Doing so may damage your discs or the DV-CP802.
- You can improve the picture quality of paused playback with the Pause/Still setting (see page 57).
- Prolonged display of the same picture or menu may cause irreparable damage to your TV screen called *screen burn-in*. To prevent this, don't keep playback paused for too long and always press the Stop [■] button when you've finished playing a DVD-Video disc or VCD. The DV-CP802 features a screen saver to protect your TV from the effects of burn-in (see page 57).
- With some DVD-Video discs, you may experience picture noise that is not normally visible with regular TV broadcasts. This is usually because DVD-Video uses a lot of high-resolution video data. The amount of noise, if any, will depend on your particular TV and the problem can sometimes be alleviated by turning down your TV's sharpness control.

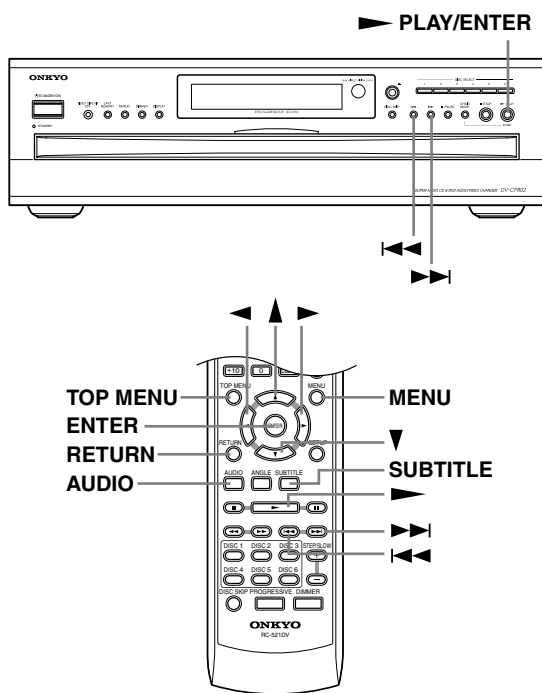

### Navigating Disc Menus

DVD-V DVD-A VCD

DVD-Video discs usually have an onscreen menu from which you can select titles, chapters, and other options, including foreign language soundtracks, subtitles, and audio formats (e.g., Dolby Digital or DTS). DVD-Audio discs sometimes have menus as well. VCDs that support PBC (Playback Control) may also have an onscreen menu (see page 7).

**1** **Load and select a DVD-Video, DVD-Audio, or VCD disc.**  
 See pages 23 and 24.  
 With DVD-Video discs, a menu usually appears automatically. If it doesn't, try pressing the [TOP MENU] button.  
 With some VCDs, you may have to press the Play [▶] button to display the menu.

**2** **Remote controller**

**Use the remote controller's arrow [▲], [▼], [◀], [▶] buttons to select items on the menu, and use the [ENTER] button to confirm your selection.**

If you select a playback option (e.g., subtitles), another menu of options will typically appear, in which case you use the remote controller's arrow buttons to select items and the [ENTER] button to confirm your choice.

With VCDs that support PBC, you have to enter a number to select a menu item, which you can do by using the remote controller's number buttons. If the VCD's menu has several pages, use the Next [▶▶] and Previous [◀◀] buttons to select them. During playback, you can display the menu by pressing the [RETURN] button.

- Notes:**
- Not all DVD-Video, DVD-Audio, and VCDs (PBC) have menus.
  - Menu operation varies from disc-to-disc. See the disc's sleeve notes for details.
  - On some DVD-Video discs, options such as foreign language soundtracks, subtitles, and audio formats appear on a separate menu called the *disc menu*, and titles and chapters appear on what's called the *title menu*. To display the disc menu, press the [MENU] button. If no menu appears, press the [TOP MENU] button.
  - With DVD-Video discs, foreign language soundtracks and audio formats can usually be selected during playback by using the remote controller's [AUDIO] button (see page 41). Similarly, subtitles can be selected by using the remote controller's [SUBTITLE] button (see page 41).
  - You must turn on PBC in order to use the menus on a VCD that supports PBC (see page 58).
  - If PBC is off (see page 58), or your VCD doesn't support it, you can use the Next [▶▶] and Previous [◀◀] buttons, or the remote controller's number buttons to select tracks on a VCD.
  - PBC menus can be hidden or displayed while playback is stopped by pressing the [TOP MENU] button.

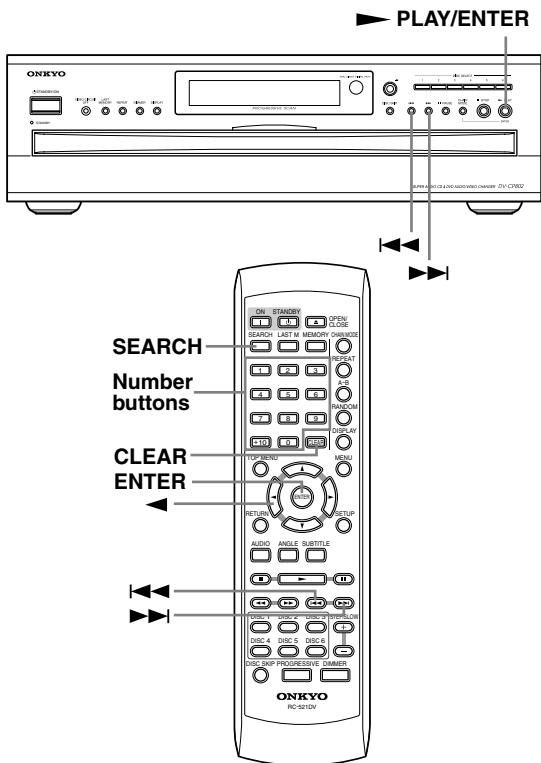

## Selecting Titles & Chapters by Number



This section explains how to select chapters and titles by number.

**1** Load and select a DVD-Video disc.  
See pages 23 and 24.

**2** Press the [SEARCH] button.  
The Disc Navigator Search window appears onscreen.

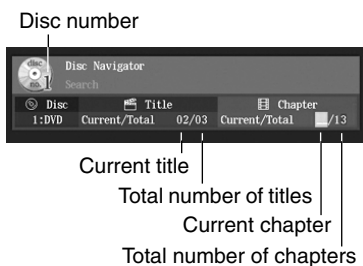

With some DVD-Video discs you can select only titles, and the Chapter Current/Total information is not displayed. Some discs won't allow you to select titles.

**3** Remote controller



If you want to select a title, press the Left [◀] button to move the cursor to the current title number.

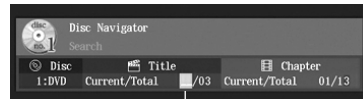

Entered title number appears here

**4** Remote controller

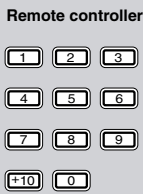

Use the number buttons to specify a chapter or title.

For example, to enter "2," press the [2] button.

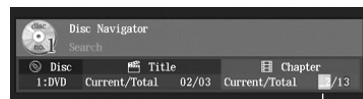

Entered chapter number appears here

For example, to enter "12," press the [1] button followed by the [2] button.

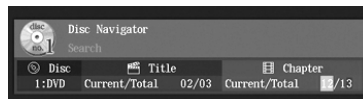

To clear a number, press the [CLEAR] button.

**5** Press the Play [▶] or [ENTER] button to start playback of the specified chapter or title.



Remote controller



During playback, you can select other chapters by using the Next [▶▶] and Previous [◀◀] buttons. The first press of the Previous [◀◀] button selects the beginning of the current chapter.

### Notes:

- During playback you can select chapters directly by using the number buttons.
- If the current DVD-Video disc contains only one title, you won't be able to select titles. Likewise, if it contains no chapters, you won't be able to select chapters.
- DVD-Video discs usually have menus for selecting titles and chapters (see page 26).
- With some discs you may not be able to select titles and chapters by number.



**5** ■ STOP

Remote controller



Remote controller



**Press the Stop [■] button to stop playback.**

**Notes:**

- If the selected JPEG file’s resolution is 640 x 480 pixels, a thumbnail-size preview will be shown. If the resolution exceeds 640 x 480, a preview will only be shown if the file contains thumbnail image data.
- You can use the Random function to play a random selection of MP3 and JPEG files (page 37).
- During random playback, the remote controller’s arrow [▲], [▼], [◀], [▶] buttons cannot be used with the Disc Navigator.
- You can use the Disc Navigator to create a playlist of MP3 and JPEG files for memory playback (see page 29).

## Memory Playback in the Disc Navigator

MP3 JPEG

You can compile a playlist of MP3/JPEG files and folders in the Disc Navigator as follows.

**1**

Remote controller

MEMORY



**With the Disc Navigator open, press the [MEMORY] button.**  
The playlist appears in place of the file information.

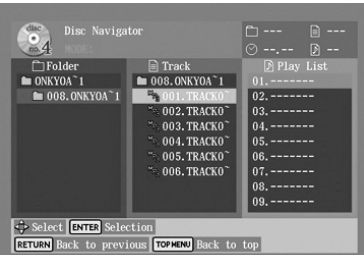

**2**

Remote controller

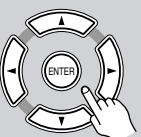

**To add a track to the playlist, use the arrow [▲], [▼], [◀], [▶] buttons to select it in the track column, and then press the [ENTER] button.**



To add an entire folder of files to the playlist, select the folder at the top of the Track list and press [ENTER]. The folder number followed by “ALL” appears in the playlist.

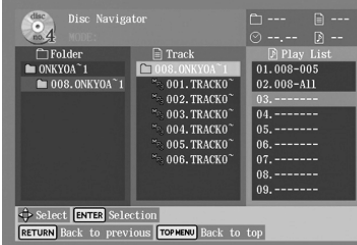

To open a folder in the Track list, press the [ENTER] button. To close a folder (i.e., move back up the directory tree), press the [RETURN] button. Alternatively, select the item at the top of the Track list and press the Play [▶] button.

**3**

▶ PLAY



ENTER

Remote controller



**To start the playlist, select any item in the Track list except the top folder and press the Play [▶] button.**  
To close the Disc Navigator Play List, press the [MEMORY] button.

**4** ■ STOP

Remote controller



Remote controller



**To stop the playlist, press the Stop [■] button.**

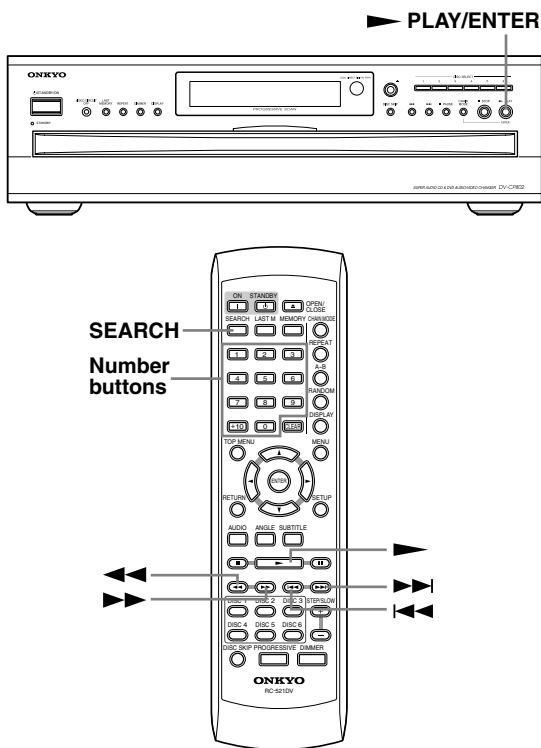

## Selecting Tracks by Number

DVD-A SACD VCD CD MP3

This section explains how to select tracks by number.

**1** Load and select a DVD-Audio, SACD, VCD, CD, or MP3 disc.  
See pages 23 and 24.

**2** During playback, press the [SEARCH] button.  
The Disc Navigator Search window appears onscreen, as shown.  
This is what appears for CDs.

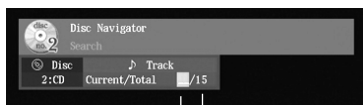

Total number of tracks  
Current track

### 3

Remote controller



Use the number buttons to enter a track number.

For example, to enter “5,” press the [5] button.

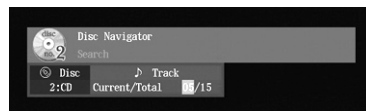

For example, to enter “11,” press the [1] button followed by the [1] button.

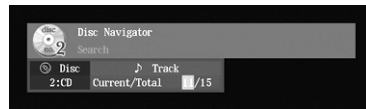

To clear a number, press the [CLEAR] button.

If you’re playing a DVD-Audio disc and want to select a track in another group, press the Left [◀] button to select the group number and enter the number of that group first.

### 4

▶ PLAY



ENTER

Remote controller

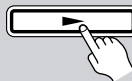

Press the Play [▶] button to start playback of the specified track.

During playback, you can select other tracks with the Next [▶▶] and Previous [◀◀] buttons. The first press of the Previous [◀◀] button selects the beginning of the current track.



#### Notes:

- You can select tracks directly at any time by using the number buttons (i.e., without pressing the [SEARCH] button).
- If PBC is on (see page 58), and the current VCD supports it, you may be able to select tracks from a menu (see page 26).
- With VCDs that support PBC, you can use the number buttons to select tracks from a menu.
- You can’t use the [SEARCH] button during random playback.

### Fast Forward & Reverse

DVD-V DVD-A SACD DVD-VR VCD CD MP3

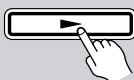
This section explains how to fast forward and reverse.

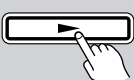
<p><b>Fast forward</b></p> <p>Remote controller</p> 	<p><b>During playback, press the Fast Forward [▶▶] button to start fast forward.</b></p> <p>Playback fast forwards and “Fast Forward1” appears onscreen.</p> <p>To change the fast-forward speed, press the Fast Forward [▶▶] button repeatedly to cycle through the speeds: Fast Forward1, Fast Forward2, and so on.</p>
<p>Remote controller</p> 	<p><b>To resume normal playback, press the Play [▶] button.</b></p>
<p><b>Fast reverse</b></p> <p>Remote controller</p> 	<p><b>During playback, press the Fast Reverse [◀◀] button to start fast reverse.</b></p> <p>Playback reverses and “Fast Reverse1” appears onscreen.</p> <p>To change the fast-reverse speed, press the Fast Reverse [◀◀] button repeatedly to cycle through the speeds: Fast Reverse1, Fast Reverse2, and so on.</p>
<p>Remote controller</p> 	<p><b>To resume normal playback, press the Play [▶] button.</b></p>

#### Notes:

- There are five fast forward and reverse speeds for DVD-Video and DVD-Audio, and three for SACD, VCD, CD, and MP3.
- No sound is output during fast forward or fast reverse of a DVD-Video disc, VCD, or DVD-VR disc.
- Sound is output intermittently during fast forward or reverse of DVD-Audio, SACD, CD, and MP3 discs.

### Frame-by-Frame Playback

DVD-V DVD-A DVD-VR VCD

With frame-by-frame playback you can view individual picture frames one at a time either forward or backward.

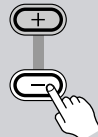
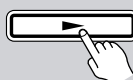
<p><b>Forward frame-by-frame</b></p> <p>Remote controller</p> <p>STEP/SLOW</p> 	<p><b>While paused, press the STEP/SLOW [+] button.</b></p> <p><b>Press the STEP/SLOW [+] button repeatedly to view subsequent frames.</b></p>
<p><b>Backward frame-by-frame</b></p> <p>Remote controller</p> <p>STEP/SLOW</p> 	<p><b>While paused, press the STEP/SLOW [-] button.</b></p> <p><b>Press the STEP/SLOW [-] button repeatedly to view previous frames.</b></p>
<p><b>Resume playback</b></p> <p>Remote controller</p> 	<p><b>To resume normal playback, press the Play [▶] button.</b></p>

#### Notes:

- Backward frame-by-frame playback does not work with VCDs and DVD-VR discs.
- You can improve the picture quality of frame-by-frame playback with the Pause/Still setting (see page 57).
- With some discs, the picture may shake when using backward frame-by-frame playback.
- No sound is output during frame-by-frame playback.
- Some DVD-Audio discs feature browsable pictures, which you can select with the STEP/SLOW [+] and [-] buttons.
- Prolonged display of the same picture or menu may cause irreparable damage to your TV screen called *screen burn-in*. To prevent this, don't display the same frame for too long. The DV-CP802 features a screen saver to protect your TV from the effects of burn-in (page 57).

## Basic Playback—Continued

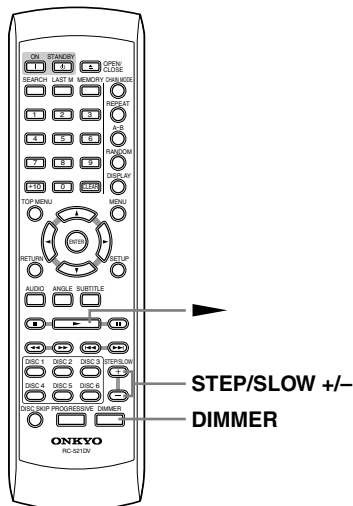
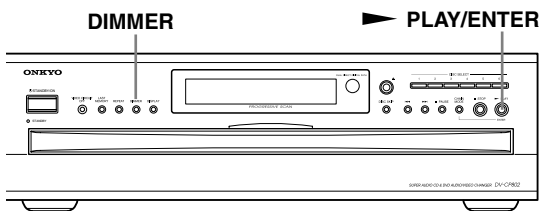

- Resume playback** To resume normal playback, press the Play [▶] button.

Remote controller

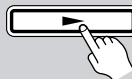

### Notes:

- There are four slow motion speeds for DVD-Video/ DVD-VR and three for VCD.
- Backward slow-motion playback does not work with VCDs and DVD-VR discs.
- No sound is output during slow-motion playback.

## Adjusting the Display Brightness

You can adjust the brightness of the display as follows.

- DIMMER** Press the [DIMMER] button repeatedly to cycle through the following options: dim, dimmer, disc tray light off, normal brightness.

Remote controller



## Slow-motion Playback

DVD-V VCD DVD-VR

With slow-motion playback you can watch a scene slowly either forward or backward.

- Forward slow motion** During playback, press the **STEP/SLOW [+]** button.

Remote controller



Forward slow-motion playback starts and “Slow1” appears onscreen. To change the slow-motion speed, press the STEP/SLOW [+] button repeatedly to cycle through the speeds: Slow1, Slow2, and so on.

- Backward slow motion** During playback, press the **STEP/SLOW [-]** button.

Remote controller

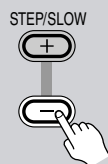

Backward slow-motion playback starts and “Slow Reverse1” appears onscreen.

To change the slow-motion speed, press the STEP/SLOW [-] button repeatedly to cycle through the speeds: Slow Reverse1, Slow Reverse2, and so on.

### Notes:

- When the display brightness on another Onkyo AV component that’s connected via **RI** is changed, the “disc tray light off” option might not work.
- Even with the “disc tray light off” option selected, the disc tray light will come on when the disc tray is opened.



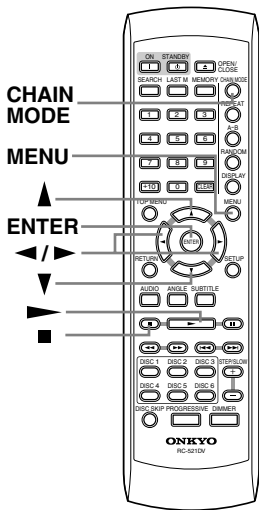
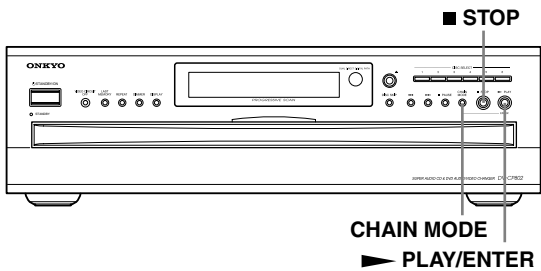

## Using JPEG CDs



The DV-CP802 supports JPEG CDs, so you can view your photos on TV either individually or as a slideshow.

1

### Load and select a JPEG CD.

Depending on the type of JPEG disc, either the first nine pictures appear in thumbnail-size or the Disc Navigator appears.

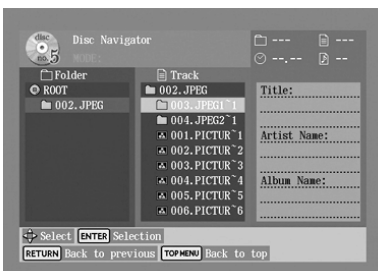

Initially, the Folder list shows all of the folders at the root level. Pressing the Play [▶] button at this point will start a slideshow of all images in all folders in hierarchical order.

The DV-CP802 numbers folders and files in hierarchical order.

2

Remote controller

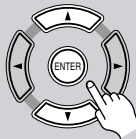

To open a folder, use the Up and Down [▲]/[▼] buttons to select it, and then press [ENTER].

The Track list shows the images and subfolders in the currently open folder.

3

Remote controller

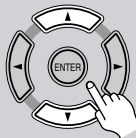

Use the Up and Down [▲]/[▼] buttons to select images and subfolders in the open folder.

A thumbnail-size preview and file size and creation date information for the currently selected image is displayed.

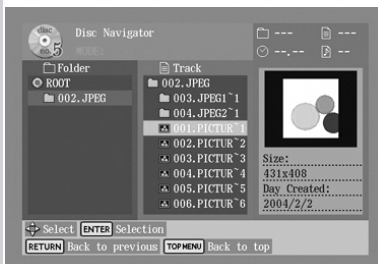

4



Remote controller

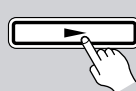

To start a slideshow, select an image in the Track list, and then press the Play [▶] or [ENTER] button.

Subsequent images in the same folder are displayed in order, with each image being displayed for five seconds. To display an image for longer, press the Pause [■] button. Press the Play [▶] button to resume.

To start a slideshow consisting of all of the images in a folder, select the folder in the Track list (not the folder at the top of the list), and then press the Play [▶] button.

5

You can use the following functions during the slideshow:

To display the next or previous image, use the Next [▶▶] or Previous [◀◀] button.

To flip a picture 180 degrees, use the Up and Down [▲]/[▼] buttons (not while zoomed in).

To rotate a picture counterclockwise or clockwise, use the Left and Right [◀]/[▶] buttons (not while zoomed in).

To zoom in or out, use the FF [▶▶] and FR [◀◀] buttons. While zoomed in, use the [◀]/[▶] and [▲]/[▼] buttons to move around the picture. The slideshow pauses while zoomed in. To cancel the zoom and resume the slideshow, press the Play [▶] button.

**6**

■ STOP



Remote controller



MENU



**To stop the slideshow, press the Stop [■] or [MENU] button.**  
Depending on the type of JPEG disc, either the first nine pictures appear in thumbnail-size or the Disc Navigator appears.  
The slideshow stops automatically when all pictures have been displayed.

**Notes:**

- If the folder containing the JPEG images also contains some MP3 tracks, the DV-CP802 will play those tracks while showing the slideshow.
- If the selected JPEG file's resolution is 640 x 480 pixels or less, a thumbnail-size preview is shown. If the resolution exceeds 640 x 480, a preview will only be shown if the file contains thumbnail data.
- You can use the Repeat function to display JPEG images repeatedly (see page 35).
- You can use the Random function to display JPEG images randomly (see page 37).

**Using Chain Mode**



In Chain mode you can play all discs sequentially.

**1**

CHAIN MODE



Remote controller



**Press the [CHAIN MODE] button repeatedly to select CD, DVD, or ALL.**  
The CHAIN M indicator flashes on the display.  
**CD:** All SACD, CD and MP3 discs are played sequentially.  
**DVD:** All DVD-Video, VCD, DVD-Audio, and DVD-VR discs are played sequentially.  
**ALL:** All discs are played sequentially.

---



**2**

▶ PLAY

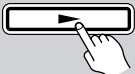

ENTER

Remote controller





**While the CHAIN M indicator is flashing, press the Play [▶] or [ENTER] button to start Chain mode playback.**  
Chain mode will be cancelled automatically if you do not start playback within five seconds of pressing the [CHAIN MODE] button.

**Notes:**

- In the DVD and All modes, VCD menus are ignored.
- With VCDs that support PBC, during chain mode playback, a menu may appear onscreen, stopping playback. To prevent this, turn off PBC (see page 58).
- JPEG files are skipped during Chain mode playback.
- In the DVD and All modes, DVD-Video menus are ignored and titles are played automatically. This may not work with some discs.
- The Repeat function cannot be used in Chain mode.
- The Random function only works with the CD setting, and only All Disc can be selected.

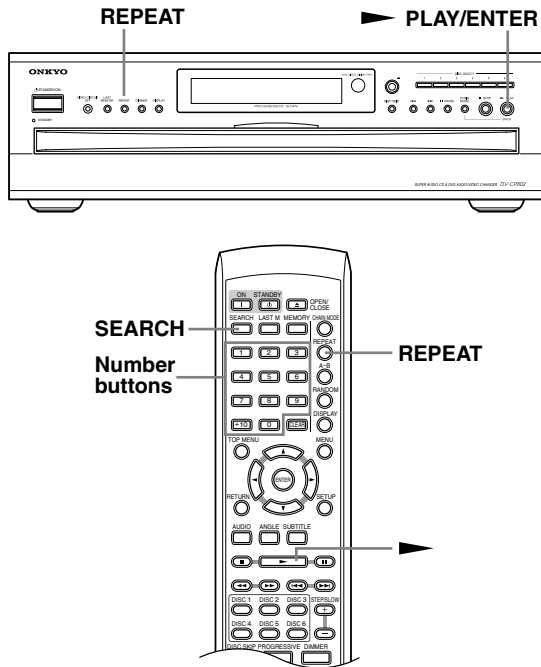
# Advanced Playback



**3** **▶ PLAY**  
**ENTER**  
**Remote controller**

**Press the Play [▶] button to start playback from the specified point.**

## Notes:

- The Time Search function works only within the currently playing title (DVD-Video and DVD-VR) or track (DVD-Audio, SACD, VCD, CD, MP3). For example, if the current title is one hour long and you enter the time 1 hour, 30 minutes, nothing will happen.
- In some cases, playback may start from a slightly different point to the one that you specify.
- Time Search may not work with some discs.
- You can't use the [SEARCH] button during random playback.
- Time search cannot be used when playing a VCD with PBC.

## Time Search

DVD-V DVD-A SACD DVD-VR VCD CD MP3

With the Time Search function you can locate specific points.

**1**  
**Remote controller**  
**SEARCH**

**Press the [SEARCH] button twice.**  
 The Disc Navigator Search window appears onscreen.

**2**  
**Remote controller**

**Use the number buttons to enter a time.**  
 For example, to enter 1 hour, 25 minutes, 30 seconds, press the [1], [2], [5], [3], and [0] buttons.

To enter 2 minutes, 15 seconds, press the [2], [1], and [5] buttons.

## Repeat Playback

DVD-V DVD-A SACD DVD-VR VCD CD MP3 JPEG

With the Repeat function you can play the current disc, title, chapter, group, track, or folder over-and-over again.

**1**  
**REPEAT**

**Remote controller**  
**REPEAT**

**Press the [REPEAT] button repeatedly to select a repeat option.**  
 The currently selected repeat option appears onscreen and "REPEAT" appears on the display.

The available options depend on the current disc type, as follows:

**DVD-Video, DVD-VR:** Chapter, Title, 1 Disc, All Disc, Repeat Off.

**DVD-Audio:** Track Repeat, Group Repeat, 1 Disc Repeat, All Disc Repeat, Repeat Off.

**SACD:** Track Repeat, 1 Disc Repeat, All Disc Repeat, Repeat Off.

**VCD:** Track, 1 Disc, All Disc, Repeat Off.

**CD:** Track, 1 Disc, All Disc.

**MP3/JPEG:** Track, Folder, 1 Disc, All Disc.

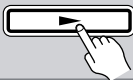
**2**  
Remote controller  

**Press the Play [▶] button to start repeat playback.**

**3**  
Remote controller  

**To cancel repeat playback, use the [REPEAT] button to select Off.**  
 If you're using the Repeat function with the Disc Navigator (MP3/JPEG), the Repeat function is off when the MODE: field is blank.

**Notes:**

- Repeat playback may not work with some DVDs.
- If you press the [REPEAT] button while the Memory function is on (see page 38), the playlist will play repeatedly.
- To use the Repeat function with a VCD that supports PBC, you must first turn off PBC (see page 58).
- You can't use the Repeat function in Chain mode.
- If you select another disc, repeat playback will be cancelled.

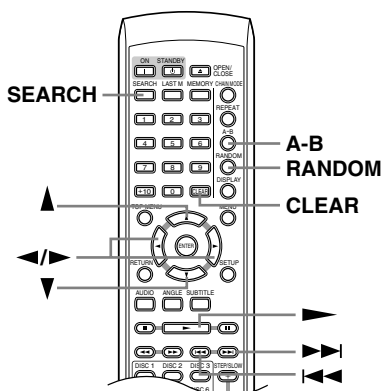
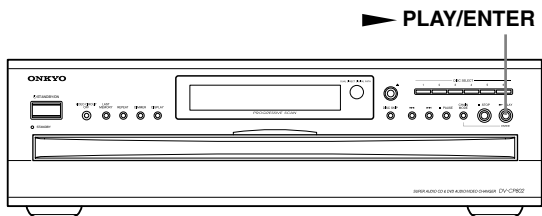

**A-B Repeat Playback**





With the A-B Repeat function you can play a specified section over-and-over again.

**1**  
Remote controller  

**During playback, press the [A-B] button to set the A point (i.e., the start of the section you want to repeat).**  
 "A—" appears onscreen.

**2**  
Remote controller  

**Press the [A-B] button again to set the B point (i.e., the end of the section you want to repeat).**  
 Playback repeats between the A and B points. "A-B" appears onscreen and "R\_AB" appears on the display.

**3**  
Remote controller  
  

**To cancel A-B Repeat, press the [CLEAR] button, or use the [A-B] button to select Off.**

**Notes:**

- The A-B Repeat function may not work with some DVD-Video discs, or VCDs that support PBC.
- In some cases, the A and B points may be at slightly different points to the ones that you specify.
- If you select a different camera angle during A-B repeat playback, the original camera angle will be selected when playback restarts from the A point.

## Random Playback

DVD-V DVD-A SACD VCD CD MP3 JPEG

With the Random function you can enjoy a random selection of discs, titles, chapters, groups, tracks, or folders.

### 1 Select a disc.

See page 24.

### 2

Remote controller

RANDOM



### Press the [RANDOM] button repeatedly to select a random option.

The currently selected random option appears onscreen and “RANDOM” appears on the display.

The available options depend on the current disc type, as follows:

**DVD-Video:** Title, 1 Disc, All Disc, Off.

**DVD-Audio:** Group Random, 1 Disc Random, All Disc Random, Random Off.

**SACD:** 1 Disc Random, All Disc Random, Random Off.

**VCD/CD:** 1 Disc, All Disc, Random Off.

**MP3/JPEG:** Folder, 1 Disc, All Disc (files in subfolders are not played).

With the “Title” option, chapters within the current title are played at random.

With the “1 Disc” option, all titles, chapters, groups, tracks, and folders on the current disc are played at random.

If you press the [RANDOM] button during playback, random playback begins after the current disc, title, chapter, group, track, or folder has finished.

### 3

▶ PLAY



ENTER

Remote controller

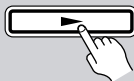

### Press the Play [▶] button to start random playback.

Random playback starts.

### 4

Remote controller

RANDOM



To cancel random playback, use the [RANDOM] button to select Off.

#### Notes:

- To select the next random disc, title, chapter, group, track, or folder during random playback, press the Next [▶▶] button.
- Random playback may not work with some DVD-Video and JPEG discs.
- To use the Random function with a VCD that supports PBC, you must first turn off PBC (see page 58).
- Random playback cannot be used with the Memory function.
- You can't use the [SEARCH] button during random playback.
- During random playback, the remote controller's arrow [▲], [▼], [◀], [▶] buttons cannot be used with the Disc Navigator.
- If you select another disc, random playback will be cancelled, except when the random option is set to “All Disc,” in which case playback continues.

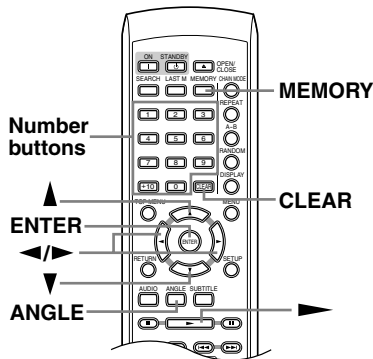

## Memory Playback

DVD-V DVD-A SACD VCD CD MP3 JPEG

With the Memory function you can create a playlist of titles, chapters, groups, tracks, or folders.

### 1

Remote controller

MEMORY



**Press the [MEMORY] button.**

The Memory Play Setup window appears onscreen and the MEMORY indicator appears on the display.



The top row (▶) is used to enter disc, title/group/folder, and chapter/track numbers. Items in the playlist are numbered sequentially.

Move the cursor to the left when you want to enter a title/group/folder number. Move it to the right to enter a chapter/track number. Move it to the far left when you want to enter a disc number. Make sure that the top row is selected before you enter a number.

### 2

Remote controller

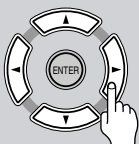

**Enter the disc, title/group/folder, and chapter/track numbers of the item you want to add to the list.**

Use the remote controller's Left and Right [◀]/[▶] buttons to select the parameters, and use the Up and Down [▲]/[▼] buttons to select numbers from 001 to 999.

The number of the current disc is already entered.

### 3

Remote controller



**Press the [ENTER] button.**

The new item is added to the list as #01.

In this example, All has been added to the list as item #01.

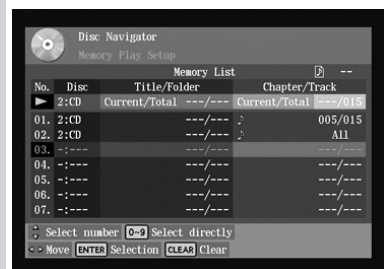

### 4

**Repeat steps 2 and 3 to add more items to the list.**

New items will be added to the list sequentially, #02, #03, and so on.

### 5

Remote controller

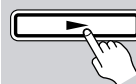

**To play the list, press the Play [▶] button.**

The Memory Play Setup window must be open when you press the Play [▶] button.

You can enter numbers directly by using the remote controller's number buttons.



To add all of the titles, groups, folders, chapters, or tracks on a disc, select the top row (▶), and then press the Down [▼] button.

To select all, while entering a number in the top row, press [0].

**6**

Remote controller



To stop playback, press the Stop  button.

### Inserting New Items into the Memory List

**1**

Remote controller





Press the [MEMORY] button.  
The Memory Play Setup window appears onscreen.

**2**

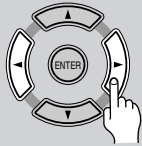
Remote controller





Use the Left or Right []/[] button to move the cursor from the top row.  
You must move the cursor away from the top row.

**3**

Remote controller



Use the Up and Down []/[] buttons to select the Memory List item before which you want to insert the new item.

**4**

Remote controller



Press the [ENTER] button to insert a new blank item.  
The cursor moves to the top row.

**5**

Enter the title/group/folder and chapter/track numbers of the item that you want to insert.

**6**

Remote controller



Press the [ENTER] button.  
The new item is inserted into the Memory List.

### Deleting Items from the Memory List

**1**

Remote controller





Press the [MEMORY] button.  
The Memory Play Setup window appears onscreen.

**2**

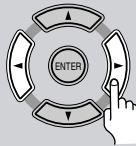
Remote controller





Use the Left or Right []/[] button to move the cursor from the top row.  
You must move the cursor away from the top row.

**3**

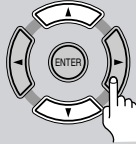
Remote controller



Use the Up and Down []/[] buttons to select the item that you want to delete.



**4**

Remote controller

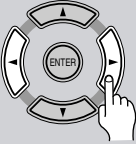

Press the [CLEAR] button to delete the item.  
The item is deleted and subsequent items move up the list.

## Changing Items in the Memory List

<p><b>1</b></p> <p>Remote controller</p> 	<p><b>Press the [MEMORY] button.</b> The Memory Play Setup window appears onscreen.</p>
<p><b>2</b></p> <p>Remote controller</p> 	<p><b>Use the Left or Right [◀]/[▶] button to move the cursor from the top row.</b> You must move the cursor away from the top row.</p>
<p><b>3</b></p> <p>Remote controller</p> 	<p><b>Use the Up and Down [▲]/[▼] buttons to select the item that you want to change.</b></p>
<p><b>4</b></p>	<p><b>Use the Left or Right [◀]/[▶] button to move the cursor to the top row.</b></p>
<p><b>5</b></p>	<p><b>Change the title/group/folder and chapter/track numbers as necessary.</b></p>
<p><b>6</b></p> <p>Remote controller</p> 	<p><b>Press the [ENTER] button to enter your changes.</b></p>



<p>Remote controller</p> 	<p><b>To close the Memory Play Setup window, press the [MEMORY] button.</b></p>
--	---

**Notes:**

- The playlist is deleted when the DV-CP802 is set to Standby.
- To use this function with a VCD that supports PBC, you must first turn off PBC (see page 58).
- With some discs you won't be able to make a playlist.

## Selecting Camera Angles



Some DVD-Video discs feature multiple camera angles that allows you to view scenes from different angles. If the disc currently playing features multiple camera angles, the camera  indicator appears on the display. Such discs usually have the multiple camera angle logo () printed on the sleeve.

<p>Remote controller</p> 	<p><b>Press the [ANGLE] button repeatedly to select the available camera angles.</b> The number of the currently selected camera angle appears onscreen. For example, on a disc with three camera angles, you'd see 1/3, 2/3, and 3/3.</p>
--	--

**Notes:**

- With some DVDs you may not be able to select different camera angles even though the camera  indicator is displayed.
- With some DVDs you can select camera angles from a menu.



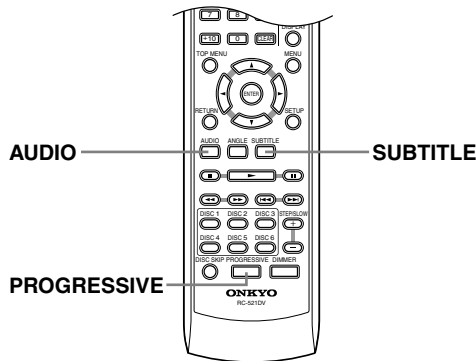

### Selecting Languages & Audio Formats



Some DVD-Video discs feature soundtracks in several languages and audio formats (e.g., Dolby Digital or DTS). Music DVD-Video discs and DVD-Audio discs sometimes feature soundtracks in several audio formats, such as PCM, Dolby Digital, or DTS. See the disc's sleeve notes for details.

Remote controller



**During playback, press the [AUDIO] button repeatedly to select the available soundtracks.**

The name of the selected soundtrack appears onscreen for several seconds.

With SACDs you can select Multichannel area, 2 channel area, or CD layer.

With VCDs you can select Stereo, Mono L (left), or Mono R (right).

#### Notes:

- With DVD-Video discs, when you stop playback and cancel the Resume function (see page 25), or select another disc, the soundtrack language will revert to your default language (see page 56), or the disc's default language.
- With some discs, selecting another soundtrack may cause the picture to skip momentarily.
- To listen to just the accompaniment on a karaoke CD, select the Mono L (left) or Mono R (right) channel. See the disc's sleeve notes for details.
- With some DVDs you must select soundtracks from a menu, and you may not be able to select other soundtracks during playback.

### Selecting Subtitles



Some DVD-Video discs feature subtitles in several languages. See the disc's sleeve notes for details.

Remote controller



**During playback, press the [SUBTITLE] button repeatedly to select the available subtitles.**

The name of the selected subtitle appears onscreen for several seconds.

To turn off subtitles, use the [SUBTITLE] button to select Off.

#### Notes:

- With DVD-Video discs, when you stop playback and cancel the Resume function (see page 25), or select another disc, the subtitle language will revert to your default subtitle language (see page 56), or the disc's default subtitle language.
- With some DVDs you must select subtitles from a menu, and you may not be able to select subtitles during playback.
- To check the current subtitle language, press the [SUBTITLE] button once. The current setting will appear onscreen for several seconds.

### Using Progressive Scanning

With progressive scanning you can enjoy better picture quality. To use progressive scanning, your TV or projector must support it and be connected to the DV-CP802's component video output (see page 18).

**1**

Remote controller



**Press the [PROGRESSIVE] button.**

Progressive scanning is enabled and the PRGSV indicator appears on the display.

**2**

Remote controller



**To turn off progressive scanning, press the [PROGRESSIVE] button again.**

The PRGSV indicator disappears.

#### Notes:

- If your TV or projector is connected to the DV-CP802's component video output and it doesn't support progressive scanning, you'll lose the picture if you turn progressive scanning on.
- When progressive scanning is turned on, nothing is output by the composite video and S-Video outputs.
- Progressive scanning cannot be turned on or off during playback. You must stop playback first.
- Progressive scanning cannot be turned on or off while the Disc Navigator is displayed.
- See also the Progressive Setting on page 50.

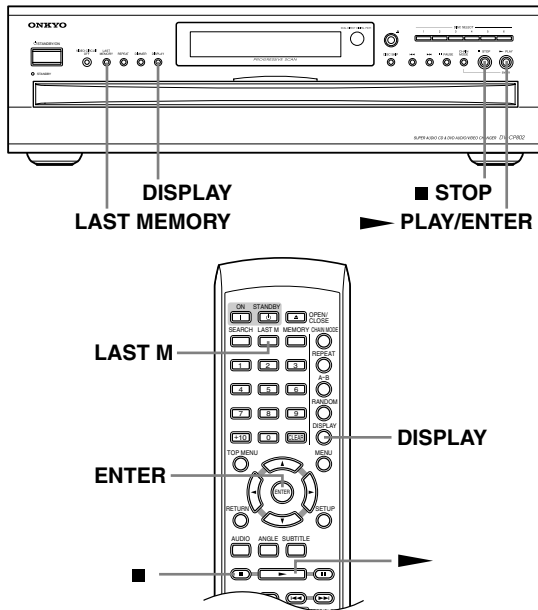

**3**

▶ PLAY

ENTER

Remote controller

To resume playback, select the disc and press the Play [▶] button.

The Last Memory dialog box appears, as shown.

**4**

Remote controller

To resume playback from the last memory point, select “Yes,” and then press [ENTER].

To start playback from the beginning, select “No,” and then press [ENTER].

To start playback from the beginning and delete the last memory point, select “Memory Clear,” and then press [ENTER].

## Using Last Memory

DVD-V VCD

With the Last Memory function you can resume playback from where you left off even if another disc has been selected or the disc has been removed. Last Memory also remembers the soundtrack and subtitle settings you were using.

**1**

LAST MEMORY

Remote controller

**During playback, press the [LAST M] button.**

The last memory point for the disc is stored, the LAST M indicator appears, and “Last Mem” appears on the display.

If the [LAST M] button is pressed again, the last memory point will be updated.

**2**

STOP

Remote controller

**To stop playback, press the Stop [■] button once or twice.**

At this point you may choose to play another disc, or to turn off the DV-CP802.

### Notes:

- The Last Memory function can store the last point for up to six DVD-Video discs. When you store the last point for a seventh disc, the first disc’s setting is lost.
- The Last Memory function can remember the last point for one VCD, but that will be lost when another disc is selected.
- The Last Memory function may not work properly with VCDs that support PBC.
- The Last Memory function will not work while a DVD menu is being displayed onscreen.
- The Last Memory function may not work with some DVD-Video discs.
- If you select another disc, or inadvertently turn off the DV-CP802 during playback, you can resume playback from the same point by selecting the disc again.

## Displaying Information

You can display various information about the current disc, title, chapter, group, or track onscreen and on the DV-CP802’s display.

**During playback, press the [DISPLAY] button repeatedly.**

The information displayed depends on the type of disc. See the following tables.



DISPLAY

Remote controller

DISPLAY

## Advanced Playback—Continued



### ■ DVD-Video

Condition	Onscreen	DV-CP802 Display
Normal	No display	Elapsed title time
1st press		Current/total title number, elapsed title time, remaining title time, total title time, selected soundtrack, selected subtitle, number of camera angles.
2nd press		Current/total chapter number, elapsed chapter time, remaining chapter time, total chapter time, bit rate.
3rd press	No display	Elapsed title time

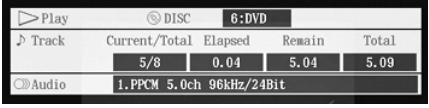
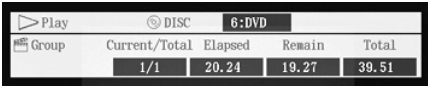
### ■ DVD-Audio

Condition	Onscreen	DV-CP802 Display
Normal	No display	Elapsed track time
1st press		Current/total track number, elapsed track time, remaining track time, total track time, selected soundtrack, selected subtitle, number of camera angles.
2nd press		Current/total group number, elapsed group time, remaining group time, total group time.
3rd press	No display	Elapsed track time

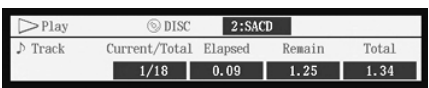
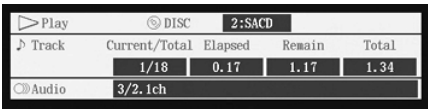
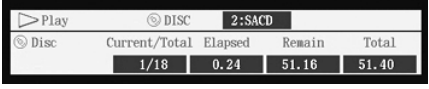

### ■ SACD

Condition	Onscreen	DV-CP802 Display
Normal	No display	Elapsed track time
1st press		Current/total track number, elapsed track time, remaining track time, total track time.
2nd press		As above plus number of audio channels.
3rd press		Current/total track number, elapsed disc time, remaining disc time, total disc time.
4th press		Title, artist name, album name.
5th press	No display	Elapsed track time

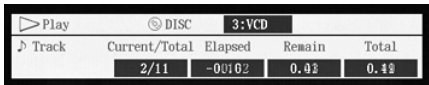

1. If the disc has no title, "No Title" appears.

## Advanced Playback—Continued

### ■ VCD & CD

Condition	Onscreen	DV-CP802 Display
Normal	No display	Elapsed track time
1st press		Current/total track number, elapsed track time, remaining track time, total track time.
2nd press		Current/total track number, elapsed disc time, remaining disc time, total disc time.
3rd press	Same as for 2nd press	Remaining disc time
4th press	No display	Elapsed track time

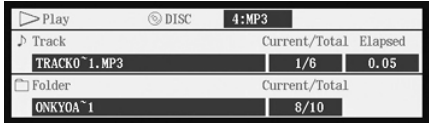
### ■ MP3

Condition	Onscreen	DV-CP802 Display
Normal		Disc Navigator <sup>1</sup>
1st press <sup>2</sup>		Current/total track number, elapsed track time, current/total folder number, file name, etc.
2nd press		Title, artist name, album name, year, genre, comment.
3rd press <sup>2</sup>	No display	File name
4th press		Disc Navigator

1. If the Disc Navigator is not shown, press the [MENU] button.

2. When another folder is selected, its name is displayed for three seconds.

#### Notes:

- For DVD-Video and DVD-Audio discs, when the soundtrack, subtitle, or camera angle is changed, the setting is displayed onscreen for 10 seconds. To cancel this display, press the [DISPLAY] button twice.
- When playback is started, paused, stopped, and so on, the status is displayed onscreen for five seconds.
- For DVD-VR discs, the bit rate is not displayed.
- No information is displayed when playing a VCD with PBC.

### Turning Off the Video Circuits

You can turn off all of the internal video circuitry, eliminating the possibility of interference for a pure-audio experience when playing audio-only discs.

**1**

VIDEO CIRCUIT  
OFF



**Press the DV-CP802's [VIDEO CIRCUIT OFF] button.**

The internal video circuitry is turned off, the [VIDEO CIRCUIT OFF] button indicator lights up, and the V.OFF indicator appears on the display.

**2**

**To turn the video circuitry back on, press the button again.**



The internal video circuitry is turned on, the [VIDEO CIRCUIT OFF] button indicator goes off, and the V.OFF indicator disappears from the display.

#### Notes:

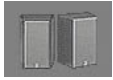

- When the video circuitry is turned off, none of the DV-CP802's video outputs work.
- With some discs you need start playback from a menu, in which case you should turn off the video circuitry after starting playback.
- Although intended for use with audio discs, this function can also be used to enjoy soundtracks and music on DVD-Video discs and VCDs.

# Configuring the DV-CP802

This chapter explains the various settings on the onscreen setup menus. Settings are arranged into six groups: *Picture*, *Audio*, *Language*, *Display*, *Operation*, and *Initial Setup*. The following table lists all of the settings, with a brief description and page number where you can find full details.

Menu	Setting	Description	Page #			
<b>Picture</b> 	TV Shape	Selects a picture format to match the aspect ratio of your TV.	48			
	Interlaced Setting	Picture adjustments for interlaced scanning.	49			
	Progressive Setting	Picture adjustments for progressive scanning.	50			
<b>Audio</b> 	Digital Out/ Digital1 (optical output) (optical)	Dolby Digital Out	Dolby Digital downmixing for the optical digital audio output.	50		
		DTS Out	DTS downmixing for the optical digital audio output.	50		
		MPEG Out	MPEG downmixing for the optical digital audio output.	50		
		Digital Out	Turns off the optical digital audio output.	51		
	Digital Out/ Digital2 (coaxial output) (coaxial)	Dolby Digital Out	Dolby Digital downmixing for the coaxial digital audio output.	51		
		DTS Out	DTS downmixing for the coaxial digital audio output.	51		
		MPEG Out	MPEG downmixing for the coaxial digital audio output.	51		
		Digital Out	Turns off the coaxial digital audio output.	51		
	Linear PCM Out		Determines whether 96 kHz digital audio is downsampled.	51		
	Analog Audio Out	2 Chan nel	Stereo, Lt/Rt	Determines how the FRONT/D.MIX AUDIO OUT sockets downmix multichannel audio.	52	
			Multi Chan nel	Dolby Pro Logic Setting		Determines how the built-in Dolby Pro Logic decoder works.
		Speaker Setting		On, Off		Specify which speakers are connected and their sizes, and enable (on) or disable (off) the Speaker Setting.
		Speaker Distance		On, Off		Specify the distance between each speaker and the listener, and enable (on) or disable (off) the Speaker Distance setting.
		Test Tone		Adjust individual speaker levels with the test tone.		
	AV Synchronization		Resynchronizes sound and picture.	54		
Dynamic Range Control (Dolby Digital Only)		Sets the Dynamic Range function.	54			
SACD Audio Setup		Determines how SACD multichannel, 2-channel, and CD tracks are played.	55			
CD Audio Setup		Configures the digital audio outputs for CD or DTS CD.	55			
<b>Language</b> 	On-Screen Language		Specify a language for the onscreen setup menus and messages.	56		
	Disc Menu Language		Specify your preferred language for disc menus.	56		
	Audio Language		Specify your preferred language for soundtracks.	56		
	Subtitle Language		Specify your preferred language for subtitles.	56		
<b>Display</b> 	On-Screen Display		Turns onscreen messages and indicators on and off.	57		
	On-Screen Display Color		Selects a color for onscreen setup menus and messages.	57		
	Background		Selects a background color for when playback is stopped.	57		
	Screen Saver		Sets the Screen Saver.	57		

## Configuring the DV-CP802—Continued

Menu	Setting	Description	Page #	
<b>Operation</b> 	Pause/Still	Selects Auto or Frame for paused and still pictures.	57	
	Parental Lock	Sets the Parental Lock function.	57	
	Title/Group Stop	Determines if playback stops at the end of the current title or group.	58	
	PBC	Turns PBC (Playback Control) for VCDs on and off.	58	
	Priority Contents	Determines what's played on DVD-Audio discs with DVD-Video content.	58	
	Auto power off	Sets the Auto power off function.	58	
<b>Initial Setup</b> 	TV Shape	This is the menu that appears automatically the very first time the DV-CP802 is turned on.	21	
	On-Screen Language			
	2 Channel			
	<table border="1"> <tr> <td>Analog Audio Out</td> <td>Multi Channel</td> <td>Speaker Setting</td> <td>On, Off</td> </tr> </table>			Analog Audio Out
Analog Audio Out	Multi Channel	Speaker Setting	On, Off	

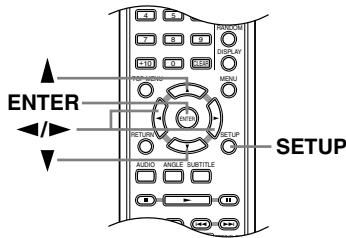

**6**  
Remote controller  
SETUP

**When you've finished, press the [SETUP] button again.**  
The onscreen setup menu closes.

## Using the Onscreen Setup Menus

This section explains how to use the onscreen setup menus.

<b>1</b>	<p><b>Turn on the DV-CP802 and your TV.</b></p> <p>On your TV, select the video input to which the DV-CP802 is connected.</p>
<b>2</b> Remote controller	<p><b>Press the [SETUP] button.</b></p> <p>The onscreen setup menu appears, as shown.</p>
<b>3</b> Remote controller	<p><b>Use the remote controller's arrow buttons to navigate the menus.</b></p> <p>Use the Left and Right [◀]/[▶] buttons to move left and right. Use the Up and Down [▲]/[▼] buttons to move up and down.</p>
<b>4</b> Remote controller	<p><b>When you've selected an item, press the [ENTER] button to see the available options.</b></p>
<b>5</b> Remote controller	<p><b>Use the arrow buttons to select the options, and press the [ENTER] button to confirm your selection.</b></p>

## Picture Menu

### TV Shape

With this setting you can select a picture format to match the aspect ratio of your TV.

#### 4:3 Letter box (default):

Choose this option if you have a 4:3 TV. When you watch widescreen movies, the entire picture will be visible, but there will be black bars at the top and bottom of the screen, as shown.



Widescreen movie on 4:3 TV with the "4:3 Letter box" setting

#### 4:3 Normal

Choose this option if you have a 4:3 TV and want to use the full height of the screen when watching widescreen movies. The picture will be cropped on both sides, as shown. This option will not work with discs that don't support pan and scan.



Widescreen movie on 4:3 TV with the "4:3 Normal" setting

#### 16:9 Widescreen

Choose this option if you have a 16:9 widescreen TV.

#### Notes:

- With some DVDs this setting may have no effect. See the disc's sleeve notes to see which picture format is used.



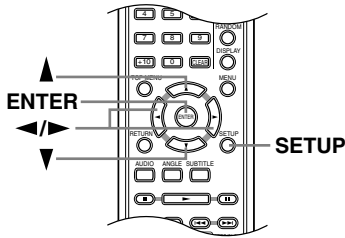

## Interlaced Setting

With this setting you can adjust various picture parameters for interlaced scanning. There are three setup memories (1, 2, 3) for storing your favorite settings. You could, for example, use one for daytime viewing (e.g., sun shining through window) and one for nighttime viewing (e.g., curtains drawn, lights down).

Parameter	Range	Description
Blacker than black	Off, On (default)	Makes black objects look even blacker.
Contrast	-7...0...+7	Adjusts the picture contrast.
Brightness	-7...0...+7	Adjusts the picture brightness.
Color	-7...0...+7	Adjusts the picture color.
Tint	-7...0...+7	Adjusts the picture tint.
Sharpness	-6...0...+6	Adjusts the picture sharpness.
S, Composite Video	Dark, Normal (default)	Adjusts the black level for the S-Video and composite video outputs.
Component Video	Dark (default), Light	Adjusts the black level for the component video outputs.
Gamma	-7...0...+7	Adjusts the brightness of darker colors.
Y/C Time Correction	-4, -2, 0, +2, +4	Corrects small shifts in color.
DNR (Digital Noise Reduction)	Off (default), 1, 2, 3	Reduces picture noise. <sup>1</sup>

1. The effect may not always be noticeable, and depending on the video source, the picture may look better with it set to Off.

### 1 Remote controller

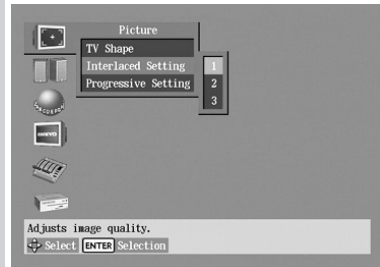
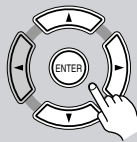

Select Interlaced Setting 1, 2, or 3, and then press the [ENTER] or Right [▶] button.

The parameters appear onscreen.

### 2 Remote controller

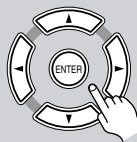

Use the Up and Down [▲]/[▼] buttons to select the parameters, press the [ENTER] button, and use the Left and Right [◀]/[▶] buttons to set them.

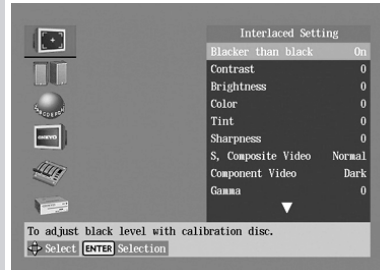

### 3 Remote controller



When you've finished, press the [ENTER] button.

The settings are stored.

Use the same procedure to set the other parameters, pressing the [ENTER] button when you've set each one.

Press the [SETUP] button to exit the onscreen setup menu.

### Notes:

- These settings are used only when the Progressive function is off.

## Progressive Setting

With this setting you can adjust various picture parameters for progressive scanning. There are three setup memories (1, 2, 3) for storing your favorite settings. You could, for example, use one for daytime viewing (e.g., sun shining through window) and one for nighttime viewing (e.g., curtains drawn, lights down).

Parameter	Range	Description
Contrast	-7...0...+7	Adjusts the picture contrast.
Brightness	-7...0...+7	Adjusts the picture brightness.
Color	-7...0...+7	Adjusts the picture color.
Tint	-7...0...+7	Adjusts the picture tint.
Sharpness	0...+7	Adjusts the picture sharpness.

**1**  
Remote controller

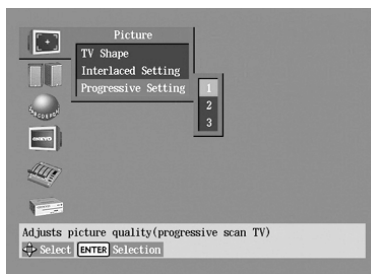
**Select Progressive Setting 1, 2, or 3, and then press the [ENTER] or Right [▶] button.**  
The parameters appear onscreen.

**2**  
Remote controller

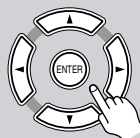

**Use the Up and Down [▲]/[▼] buttons to select the parameters, press the [ENTER] button, and use the Left and Right [◀]/[▶] buttons to set them.**

**3**  
Remote controller



**When you've finished, press the [ENTER] button.**  
The settings are stored.  
Use the same procedure to set the other parameters, pressing the [ENTER] button when you've set each one.  
Press the [SETUP] button to exit the onscreen setup menu.

### Notes:

- These settings are used only when the Progressive function is on.

## Audio Menu

### Digital Out/Digital1 (optical output)

With these settings you can determine how the DV-CP802 outputs digital audio from its OPTICAL DIGITAL AUDIO OUTPUT. The options you choose will depend on the type of component that you connect.

#### ■ Dolby Digital Out

With this setting you can configure the OPTICAL DIGITAL AUDIO OUTPUT to output Dolby Digital audio as it is or to downmix it into 2-channel PCM.

##### Dolby Digital (default)

Choose this option if you're connecting a component with a built-in Dolby Digital decoder.

##### Dolby Digital > PCM

Choose this option if you're connecting a stereo hi-fi amp with a digital input, an AV receiver with a built-in Dolby Pro Logic decoder, or an external D/A converter.

#### ■ DTS Out

With this setting you can configure the OPTICAL DIGITAL AUDIO OUTPUT to output DTS audio as it is or to downmix it into 2-channel PCM.

##### DTS (default)

Choose this option if you're connecting a component with a built-in DTS decoder.

##### DTS > PCM

Choose this option if you're connecting a stereo hi-fi amp with a digital input or an external D/A converter.

#### ■ MPEG Out

With this setting you can configure the OPTICAL DIGITAL AUDIO OUTPUT to output MPEG audio as it is or to downmix it into 2-channel PCM.

##### MPEG

Choose this option if you're connecting a component with a built-in MPEG decoder.

##### MPEG > PCM (default)

Choose this option if you're connecting a stereo hi-fi amp with a digital input or an external D/A converter.

### ■ Digital Out

With this setting you can turn the OPTICAL DIGITAL AUDIO OUTPUT on or off. Depending on how you connect the DV-CP802 to your other components, this can be useful in certain situations.

#### On (default)

OPTICAL DIGITAL AUDIO OUTPUT is on.

#### Off

OPTICAL DIGITAL AUDIO OUTPUT is off.

#### Notes:

- This setting has no effect on the analog audio outputs.

### **Digital Out/Digital2 (coaxial output)**

---

With these settings you can determine how the DV-CP802 outputs digital audio from its COAXIAL DIGITAL AUDIO OUTPUT. The options you choose will depend on the type of component that you connect.

### ■ Dolby Digital Out

With this setting you can configure the COAXIAL DIGITAL AUDIO OUTPUT to output Dolby Digital audio as it is or to downmix it into 2-channel PCM.

#### Dolby Digital (default)

Choose this option if you're connecting a component with a built-in Dolby Digital decoder.

#### Dolby Digital > PCM

Choose this option if you're connecting a stereo hi-fi amp with a digital input, an AV receiver with a built-in Dolby Pro Logic decoder, or an external D/A converter.

### ■ DTS Out

With this setting you can configure the COAXIAL DIGITAL AUDIO OUTPUT to output DTS audio as it is or to downmix it into 2-channel PCM.

#### DTS (default)

Choose this option if you're connecting a component with a built-in DTS decoder.

#### DTS > PCM

Choose this option if you're connecting a stereo hi-fi amp with a digital input or an external D/A converter.

#### Notes:

- When playing the DTS audio of a DTS CD, set the CD Audio Setup setting to DTS (see page 55).

### ■ MPEG Out

With this setting you can configure the COAXIAL DIGITAL AUDIO OUTPUT to output MPEG audio as it is or to downmix it into 2-channel PCM.

#### MPEG

Choose this option if you're connecting a component with a built-in MPEG decoder.

#### MPEG > PCM (default)

Choose this option if you're connecting a stereo hi-fi amp with a digital input or an external D/A converter.

### ■ Digital Out

With this setting you can turn the COAXIAL DIGITAL AUDIO OUTPUT on or off. Depending on how you connect the DV-CP802 to your other components, this can be useful in certain situations.

#### On (default)

COAXIAL DIGITAL AUDIO OUTPUT is on.

#### Off

COAXIAL DIGITAL AUDIO OUTPUT is off.

#### Notes:

- This setting has no effect on the analog audio outputs.

### **Linear PCM Out**

---

With this setting you can configure the DV-CP802 to output digital audio with a high sampling rate (e.g., 96 kHz) as it is or to downsample it to 48 kHz. This setting applies to the OPTICAL and COAXIAL DIGITAL AUDIO OUTPUT.

#### Down Sample On

Choose this option if the component connected to a DIGITAL AUDIO OUTPUT doesn't support high sampling rates.

#### Down Sample Off (default)

Choose this option if the connected component does support high sampling rates.

#### Notes:

- Some copy-protected DVD-Video discs may use 96 kHz digital audio only for A/D conversion to the analog audio outputs.
- With some discs, even if you select Down Sample Off, digital audio will be downsampled to 48 kHz regardless, and in some cases, digital audio may not be output by the DV-CP802's digital audio outputs.

## Analog Audio Out

With this setting you can configure the FRONT/D.MIX, SURR 1/SURR 2, CENTER, and SUBWOOFER AUDIO OUTPUTs for use with a 2-channel amp or a multichannel amp.

### ■ 2 Channel

Choose this option if you're connecting just the FRONT/D.MIX AUDIO OUTPUTs to a stereo amp. Multichannel audio will be downmixed into 2 channels and output by the FRONT/D.MIX AUDIO OUTPUTs.

### ■ Stereo Lt/Rt (Downmix)

To access this setting, select 2 Channel, and then press the [ENTER] or Right [▶] button.

With this setting you can determine how the FRONT/D.MIX AUDIO OUT sockets downmix multichannel audio sources.

#### Stereo (default)

Choose this option if you're connecting the FRONT/D.MIX AUDIO OUT sockets to a stereo amp or TV. Multichannel audio is downmixed into stereo.

#### Lt/Rt

Choose this option if you're connecting the FRONT/D.MIX AUDIO OUT sockets to an AV receiver, TV, or other component with a built-in Dolby Pro Logic decoder. Multichannel audio is downmixed into an Lt/Rt mix, which is a 2-channel mix containing front left, front right, center, and surround channel information.

### ■ Multi Channel (default)

Choose this option if you're connecting the FRONT/D.MIX, SURR 1/SURR 2, CENTER, and SUBWOOFER AUDIO OUTPUTs to a multichannel amp. The FRONT/D.MIX AUDIO OUTPUTs will output the front left and right channel audio. When Multi Channel is selected, you can also set the following settings:

- Dolby Pro Logic Setting
- Speaker Setting
- Speaker Distance
- Test Tone

### ■ Dolby Pro Logic Setting

This setting determines how the DV-CP802's built-in Dolby Pro Logic decoder works with 2-channel material.

#### Auto (default)

The Dolby Pro Logic decoder automatically detects and decodes only Dolby Surround material.

#### On

The Dolby Pro Logic decoder decodes Dolby Surround material and processes the following audio formats: 2-channel Dolby Digital on DVD-Video discs, 48 kHz (16-, 20-, and 24-bit) PCM audio on DVD-Video discs, and 2-channel audio on CDs.

#### Off

The Dolby Pro Logic decoder is off.

### Notes:

- In the Analog Audio Out, Speaker Setting, if Center Speaker or Surround Speaker is set to Off (page 21, 53), the Dolby Pro Logic decoder will not work even if you select Auto or On.

### ■ Speaker Setting, Speaker Distance

With these settings you can enable or disable the Speaker Setting and Speaker Distance settings.

#### On

The Speaker Setting and Speaker Distance settings are enabled. These settings are explained in the following sections.

#### Off

The Speaker Setting and Speaker Distance settings are disabled. Select this option if you connect the multichannel analog audio output to a multichannel analog audio input on an AV receiver that has its own speaker and distance settings.

Selecting Off is essentially the same as setting the Speaker Setting Front, Center, and Surround settings to Large, the Subwoofer setting to On, and the Speaker Distance settings to zero.

### ■ Test Tone

The test tone is used to adjust the level of each speaker (see page 54).

## Setting the Speaker Settings

1

Remote controller

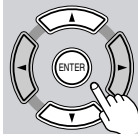

Use the Up and Down [▲]/[▼] buttons to select Speaker setting, press the [ENTER] button, use the Up and Down [▲]/[▼] buttons to select On, and then press the [ENTER] button.

When the Speaker Setting is set to Off, these settings cannot be selected.



2

Remote controller

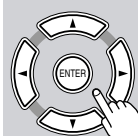

Use the Up and Down [▲]/[▼] buttons to select Subwoofer, press the [ENTER] button, use the Left and Right [◀]/[▶] buttons to select an option, and then press [ENTER] again.

**Off:** Select if no subwoofer is being used.

**On (default):** Select if a subwoofer is being used.

**3**

Remote controller

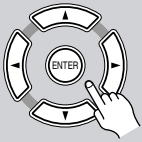

Use the Up and Down [▲]/[▼] buttons to select Front Speaker, press the [ENTER] button, use the Left and Right [◀]/[▶] buttons to select an option, and then press [ENTER] again.

When setting the Speaker Setting, for speakers with a cone diameter larger than 6-1/2 inches (16 cm), specify *Large*. For those with a smaller diameter, specify *Small*. If you're using THX-certified speakers, specify *Small* for all speakers.

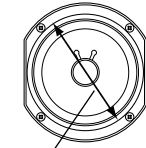

Cone diameter

**Large:** Select if the front speakers are large.

**Small (default):** Select if the front speakers are small.

Note that if the Subwoofer setting is set to Off, this setting is fixed at Large.

**4**

Remote controller

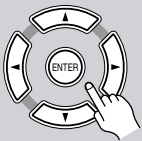

Use the Up and Down [▲]/[▼] buttons to select Center Speaker, press the [ENTER] button, use the Left and Right [◀]/[▶] buttons to select an option, and then press [ENTER] again.

**Large:** Select if the center speaker is large.

**Small (default):** Select if the center speaker is small.

**Off:** Select if no center speaker is being used.

Note that if the Front Speaker setting is set to Small, the Large option cannot be selected. And if the Subwoofer setting is set to Off, only the Large and Off options can be selected.

**5**

Remote controller



Use the Up and Down [▲]/[▼] buttons to select Surround Speaker, press the [ENTER] button, use the Left and Right [◀]/[▶] buttons to select an option, and then press [ENTER] again.

**Large:** Select if the surround speakers are large.

**Small (default):** Select if the surround speakers are small.

**Off:** Select if no surround speakers are being used.

If the Subwoofer setting is set to Off, only the Large and Off options can be selected.

**6**

Remote controller



When you've finished, press the [SETUP] button to exit setup, or press the Left [◀] button repeatedly to go back to the main setup menu.

**Setting the Speaker Distances**

**1**

Remote controller



Use the Up and Down [▲]/[▼] buttons to select Speaker Distance, press the [ENTER] button, use the Up and Down [▲]/[▼] buttons to select On, and then press [ENTER] again.

When the Speaker Distance is set to Off, these settings cannot be selected.

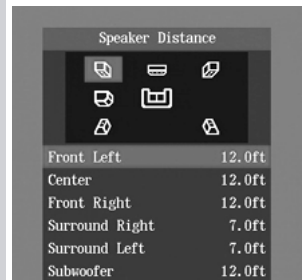

**2**

Remote controller

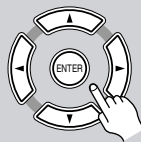

Use the Up and Down [▲]/[▼] buttons to select a speaker, press the [ENTER] button, use the Left and Right [◀]/[▶] buttons to specify the distance from that speaker to the listening position, and then press [ENTER] again.

Repeat for each speaker.

Speaker distances can be specified in steps of 1.0 ft.

Speaker	Range	Default
Front Left	1.0–30.0 ft.	12 ft.
Center		
Front Right		
Surround Right	1.0–30.0 ft.	7.0 ft.
Surround Left		
Subwoofer		

**Notes:**

- If the distance between the furthest and nearest speakers is greater than 20 feet, corrected values suitable for home theater use will be set automatically.

## Configuring the DV-CP802—Continued

**3**

Remote controller

SETUP



When you've finished, press the [SETUP] button to exit setup, or press the Left [◀] button repeatedly to go back to the main setup menu.

**3**

Remote controller

SETUP



When you've finished, press the [SETUP] button to exit setup, or press the Left [◀] button repeatedly to go back to the main setup menu.

### Note:

- The Speaker Distance settings have no effect on SACD (multichannel area and 2-channel area) and 196 kHz/176.4 kHz DVD-Audio.

## Setting Levels With the Test Tone

**1**

Remote controller



Use the Up and Down [▲]/[▼] buttons to select Test Tone, and then press the [ENTER] button.

The Test Tone settings appear onscreen.



**2**

Remote controller



Use the Up and Down [▲]/[▼] buttons to select a speaker, press the [ENTER] button, use the Left and Right [◀]/[▶] buttons to adjust the level, and then press [ENTER] again.

Repeat for each speaker.

A test tone is output by each speaker as it is selected.

Speaker levels can be adjusted in 1 dB steps.

Speaker	Range	Default
Front Left	-12 dB to 0 dB	0 dB
Center		
Front Right		
Surround Right		
Surround Left		
Subwoofer		

You cannot set the level of speakers that are set to Off.

## AV Synchronization

When using progressive scanning you may find that the picture and sound are out of sync. With this setting you can delay the audio to correct this. There are three setup memories (1, 2, 3) for storing settings for up to three components. Memories 2 and 3 are already set at 50 ms, which is a good starting point when compensating for the video delay caused by a typical projector with a built-in scaler.

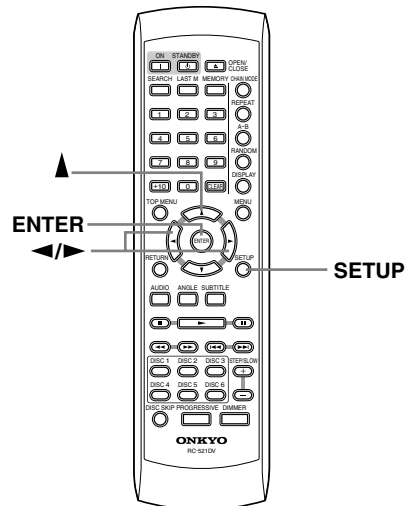

## Selecting the AV Synchronization

**1**

Remote controller

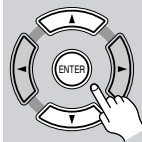

Use the Up and Down [▲]/[▼] buttons to select setup 1, 2, or 3, and then press the [ENTER] or Right [▶] button.

The parameters appear onscreen.

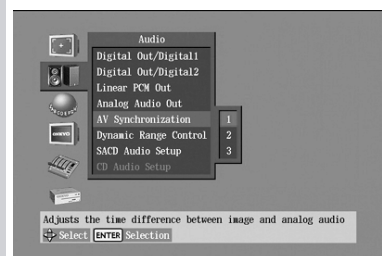

## 2

Remote controller

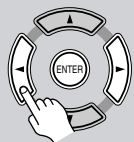

Use the Left and Right [◀]/[▶] buttons to set the delay time.

Memory	Range	Default
1	0–100 ms	0 ms
2		50 ms
3		50 ms

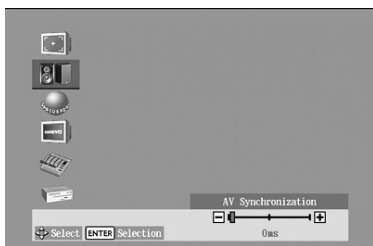

## 3

Remote controller

SETUP



When you've finished, press the [SETUP] button.

The settings are stored.

### Notes:

- This setting affects only the analog multichannel output. To delay audio from the other outputs, use the delay settings (i.e., the speaker distance settings) on the connected AV receiver.
- The AV Synchronization setting has no effect on SACD (multichannel area and 2-channel area) and 196 kHz/176.4 kHz DVD-Audio.

## Dynamic Range Control (Dolby Digital Only)

DVD-V DVD-A

With the Dynamic Range Control you can reduce the dynamic range of Dolby Digital material so that you can still hear quiet parts even when listening at low volume levels—ideal for watching movies late at night when you don't want to disturb anyone.

### Off (default)

The full dynamic range is preserved.

### On

The dynamic range is reduced.

### Notes:

- The impact of the Dynamic Range Control depends on the Dolby Digital material that you are playing and with some material there will be little or no effect.
- This setting automatically reverts to Off when the DV-CP802 is turned on.

## SACD Audio Setup

SACD

SACDs have two separate areas for storing audio—one for multichannel audio, the other for 2-channel stereo audio. In addition, hybrid SACDs have an extra layer for playback in standard CD players. With this setting you can determine how SACDs are played by the DV-CP802.

### 2 ch Area

The 2-channel stereo audio is played.

### Multi ch Area (default)

The multichannel audio is played.

### CD Area

The CD layer of hybrid SACDs is played.

### Notes:

- If Multi ch Area is selected, and an SACD that contains no multichannel area is loaded, the 2-channel area will be played.

## CD Audio Setup

CD

This setting configures the digital audio outputs for use with normal CDs or DTS CDs.

### PCM (default)

Choose this option when playing normal audio CDs.

### DTS

Choose this option when playing DTS CDs.

### Notes:

- This setting can be set only when the DTS Out setting for Digital Out/Digital 1 or 2 is set to "DTS->PCM."

### Language Menu

#### On-Screen Language

---

With this setting you can select a language for the onscreen setup menus and messages.

- English (default):** English
- Français:** French
- Español:** Spanish
- Deutsch:** German
- Italiano:** Italian
- 日本語:** Japanese

#### Disc Menu Language

---



With this setting you can specify your preferred language for DVD menus. When you play a disc with menus available in several languages, your preferred language will be selected automatically.

- English (default):**
- French:**
- Spanish:**
- German:**
- Italian:**
- Japanese:**
- Others:**

See “Selecting Other Languages” on page 59.

#### Notes:

- Not all DVDs have menus in multiple languages.
- Even if a DVD has menus in multiple languages, this setting may not always work.
- If a DVD has only one menu language, that will be used.
- With some DVDs you can select languages from a menu.

#### Audio Language

---



With this setting you can specify your preferred language for soundtracks. When you play a DVD with multiple language soundtracks, your preferred language will be selected automatically.

- English (default):**
- French:**
- Spanish:**
- German:**
- Italian:**
- Japanese:**
- Others:**

See “Selecting Other Languages” on page 59.

#### Notes:

- Not all DVDs have soundtracks in multiple languages.
- Even if a DVD has soundtracks in multiple languages, this setting may not always work.
- If a DVD has only one soundtrack, that will be used.
- With some DVDs you can select languages from a menu.

#### Subtitle Language

---



With this setting you can specify your preferred language for subtitles. When you play a DVD with multiple language subtitles, your preferred language will be selected automatically.

- English:**
- French:**
- Spanish:**
- German:**
- Italian:**
- Japanese:**
- No Subtitle (default):**

No subtitles will be displayed. This option is useful with DVDs that always display subtitles.

#### Others:

See “Selecting Other Languages” on page 59.

#### Notes:

- Not all DVDs have subtitles.
- Even if a DVD has subtitles in multiple languages, this setting may not always work.
- If a DVD has only one subtitle language, that will be used.
- With some DVDs you can select subtitles from a menu.



### Display Menu

#### On-Screen Display

With this setting you can turn on or off onscreen messages, such as “Play,” “Stop,” and “Resume.”

**Off:** Onscreen messages off.

**On (default):** Onscreen messages on.

#### On-Screen Display Color

With this setting you can set the color and theme for the Disc Navigator.

**Sapphire (default):**

**Pearl:**

**Amethyst:**

**Garnet:**

#### Background

With this setting you can select the color of the background that’s displayed while playback is stopped.

**Blue:**

**Gray:**

**Graphic (default):**

The theme picture specified for the On-Screen Display Color setting is used.

#### Screen Saver

With the screen saver you can protect your TV against screen burn-in, which can occur when the same picture is displayed for a long time.

**Off:** Screen saver off.

**On (default):** Screen saver on.

When the screen saver is set to On, and DVD-Video or VCD playback is paused or stopped for 15 minutes, the screen saver automatically displays a moving image.

Once the screen saver has been activated, you can cancel it by pressing either the Play [▶] or Pause [■] button.

#### Notes:

- The screen saver also works with DVD-Audio, SACD, CD, MP3, and JPEG discs. In this case, if you leave playback paused for five minutes, the screen saver will activate.

### Operation Menu

#### Pause/Still

DVD-V

The Pause/Still setting determines how still pictures are displayed when playback is paused and when frame-by-frame playback is used.

**Auto (default)**

A frame or field is displayed depending on the disc.

**Frame**

A frame is displayed.

TV pictures are made up of fields, and there are two fields per picture (*frame*). In general, the Frame option will provide the best picture quality, although in some cases the picture may appear slightly blurred. Since a field has only half as much information, the picture quality will be lower when a field is displayed, but it won’t be blurred.

#### Parental Lock

DVD-V

With the Parental Lock function you can block access to scenes that DVD authors have flagged as being unsuitable for children.

1

Remote controller



**Select Parental Lock→On, and then press the [ENTER] button.**

The Security Code box appears onscreen.



2

Remote controller



**Use the number buttons to enter a 4-digit security code, and then press [ENTER].**

The Level box appears onscreen.

### 3

Remote controller

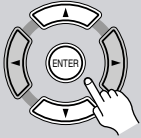

**Use the Up and Down [▲]/[▼] buttons to specify the parental lock level from 1 through 8, and then press [ENTER].**

The parental lock is now set.

The parental lock levels conform to U.S. movie ratings as follows:

- Level 7: NC-17
- Level 6: R
- Level 4: PG13
- Level 3: PG
- Level 1: G

### 4

Remote controller

SETUP



**When you've finished, press the [SETUP] button.**

The settings are stored.

#### Notes:

- When entering the security code, you can use the [CLEAR] button to delete numbers.
- This setting can be changed only when playback is stopped.
- Once this setting has been turned on and a security code set, if you want to turn off parental lock, or change the parental lock level, you'll be prompted to enter the security code.
- Not all discs use parental lock. See the disc's sleeve notes for details.
- Discs with parental lock may cut certain scenes, replace certain scenes with children-friendly scenes, or prevent playback of the entire disc.
- If you forget the security code, instead of entering the numbers, press the STOP [■] button four times.
- When using a disc that supports parental control, depending on the DV-CP802's operating status, sometimes you may not be able to remove the disc simply by pressing the [OPEN/CLOSE] button. In this case, close the disc tray, use the [DISC SKIP] button to select another disc bay, open the tray again, and then remove the disc.

### Title/Group Stop



With this setting you can determine whether or not playback stops when the title or group that's currently playing ends.

#### Off (default)

Playback continues when the title or group ends.

#### On

Playback stops when the title or group ends.

### PBC



This setting is used to enable or disable PBC (Playback Control) for VCDs.

#### Off

PBC disabled.

#### On (default)

PBC enabled.

#### Notes:

- PBC functionality depends on the disc. See the disc's sleeve notes for details.
- Some VCDs may not use all of the PBC functions supported by the DV-CP802.

### Priority Contents



This setting determines what's played when a DVD-Audio disc also contains DVD-Video material.

#### DVD-AUDIO (default)

The DVD-Audio material is played.

#### DVD-VIDEO

The DVD-Video material is played.

### Auto power off

The Auto power off function automatically turns off the DV-CP802 after 20 minutes of inactivity.

#### Off (default)

Auto power off function off.

#### On

Auto power off function on.



## Configuring the DV-CP802—Continued

### Initial Setup Menu

This menu appears automatically the very first time you turn on the DV-CP802. See “First Time Setup” on page 21 for more information.

### Selecting Other Languages

This section explains how to select other languages for disc menus, audio, and subtitles.

<b>1</b>	Remote controller		<p><b>Select “Others” from the Disc Menu Language, Audio Language, or Subtitle Language menu, and then press [ENTER].</b></p> <p>The language code boxes appear.</p>
<b>2</b>	Remote controller		<p><b>Use the remote controller’s Left and Right [◀/▶] buttons to select the code boxes.</b></p> <p><b>Use the Up and Down [▲]/[▼] buttons to enter a language code.</b></p> <p>See the adjacent table for language codes.</p>
<b>3</b>	Remote controller		<p><b>When you’ve finished, press the [ENTER] button.</b></p>

### Language Code List

Use this list when specifying other languages.

Language	Code	Language	Code
Japanese	JA	Kirghiz	KY
English	EN	Latin	LA
French	FR	Lingala	LN
German	DE	Laothian	LO
Italian	IT	Lithuanian	LT
Spanish	ES	Latvian	LV
Chinese	ZH	Malagasy	MG
Dutch	NL	Maori	MI
Portuguese	PT	Macedonian	MK
Swedish	SV	Malayalam	ML
Russian	RU	Mongolian	MN
Korean	KO	Moldavian	MO
Greek	EL	Marathi	MR
Afar	AA	Malay	MS
Abkhazian	AB	Maltese	MT
Afrikaans	AF	Burmese	MY
Amharic	AM	Nauru	NA
Arabic	AR	Nepali	NE
Assamese	AS	Norwegian	NO

Language	Code
Aymara	AY
Azerbaijani	AZ
Bashkir	BA
Byelorussian	BE
Bulgarian	BG
Bihari	BH
Bislama	BI
Bengali	BN
Tibetan	BO
Breton	BR
Catalan	CA
Corsican	CO
Czech	CS
Welsh	CY
Danish	DA
Bhutani	DZ
Esperanto	EO
Estonian	ET
Basque	EU
Persian	FA
Finnish	FI
Fiji	FJ
Faroese	FO
Frisian	FY
Irish	GA
Scots-Gaelic	GD
Galician	GL
Guarani	GN
Gujarati	GU
Hausa	HA
Hindi	HI
Croatian	HR
Hungarian	HU
Armenian	HY
Interlingua	IA
Interlingue	IE
Inupiak	IK
Indonesian	IN
Icelandic	IS
Hebrew	IW
Yiddish	JI
Javanese	JW
Georgian	KA
Kazakh	KK
Greenlandic	KL
Cambodian	KM
Kannada	KN
Kashmiri	KS
Kurdish	KU

Language	Code
Occitan	OC
Oromo	OM
Oriya	OR
Panjabi	PA
Polish	PL
Pashto, Pushto	PS
Quechua	QU
Rhaeto-Romance	RM
Kirundi	RN
Romanian	RO
Kinyarwanda	RW
Sanskrit	SA
Sindhi	SD
Sangho	SG
Serbo-Croatian	SH
Sinhalese	SI
Slovak	SK
Slovenian	SL
Samoan	SM
Shona	SN
Somali	SO
Albanian	SQ
Serbian	SR
Siswati	SS
Sesotho	ST
Sundanese	SU
Swahili	SW
Tamil	TA
Telugu	TE
Tajik	TG
Thai	TH
Tigrinya	TI
Turkmen	TK
Tagalog	TL
Setswana	TN
Tonga	TO
Turkish	TR
Tsonga	TS
Tatar	TT
Twi	TW
Ukrainian	UK
Urdu	UR
Uzbek	UZ
Vietnamese	VI
Volapük	VO
Wolof	WO
Xhosa	XH
Yoruba	YO
Zulu	ZU

# Troubleshooting

Symptom	Possible cause	Remedy
<b>Can't turn on the DV-CP802?</b>	The power cord is not connected.	Connect the power cord to a suitable wall outlet (page 21).
	External interference is affecting the DV-CP802's digital circuitry.	Turn off the DV-CP802, wait five seconds, then try turning it on again. If that fails, disconnect the power cord from the wall outlet, wait five seconds, reconnect it, then try turning it on again.
<b>The DV-CP802 turns itself off when it's not being used?</b>	The Auto power off function will turn the DV-CP802 off automatically after 20 minutes of inactivity.	The Auto power off function can be turned on or off as required (page 58).
<b>No picture?</b>	The wrong input source is selected on your TV.	On your TV, select the input to which the DV-CP802 is connected (page 18).
	The video cable is not connected properly.	Check the video cable and correct as necessary (page 18).
<b>No sound?</b>	The wrong input source is selected on your hi-fi amp or AV receiver.	On your hi-fi amp or AV receiver, select the input to which the DV-CP802 is connected (page 20).
	The audio cables are not connected properly.	Check the audio cables and correct as necessary (page 20).
	Your hi-fi amp or AV receiver is turned off.	Turn on your hi-fi amp or AV receiver.
	The Digital Out settings are incorrect.	Check the Digital Out/Digital1 and Digital2 settings and correct as necessary (page 50).
<b>The picture distorts occasionally?</b>	The disc is dirty.	Remove the disc and clean it (page 9).
	You're using the Fast Forward or Fast Reverse function.	A little picture distortion may occur when using these functions. This is normal.
<b>Picture instability or noise?</b>	The DV-CP802 is connected to your TV via a VCR or other video equipment whose copy protection system is affecting the picture.	Connect the DV-CP802 directly to your TV (page 18).
<b>Can't start playback?</b>	No discs loaded.	Load some discs (page 23).
	The selected disc cannot be played because it's incompatible.	Load only compatible discs (page 7).
	The disc is upside down.	Load the disc the correct way up (page 23).
	The disc is not centered in the disc bay.	Place the disc in the center of the disc bay (page 23).
	The disc is dirty.	Remove the disc and clean it (page 9).
	The selected disc has parental lock and the Parental Lock function is on.	Turn off the Parental Lock function (page 57).
<b>Can't watch the DVD-Video material on a DVD-Audio disc?</b>	The Priority Contents setting is set to DVD-AUDIO.	Set the Priority Contents setting to DVD-VIDEO (page 58).
<b>Can't play the multichannel area of a hybrid SACD?</b>	The SACD Audio Setup setting is not set to Multi ch Area.	Set the SACD Audio Setup setting to Multi ch Area (page 55).
<b>Can't play an MP3 or JPEG disc?</b>	The disc is not ISO 9660 Level 2 format.	Use only ISO 9660 Level 2 format discs (page 8).
	The disc has not been finalized.	Finalize the disc (page 8).

## Troubleshooting—Continued

Symptom	Possible cause	Remedy
Can't select MP3 files?	MP3 files without a “.mp3” or “.MP3” filename extension are not recognized.	Use the correct filename extension (page 8).
	The MP3 disc is a multisession disc.	Only files in the first session of a multisession disc can be played (page 8).
Can't view JPEG files?	JPEG files without a “.jpg” or “.JPG” or “.JPEG” filename extension are not recognized.	Use the correct filename extension (page 8).
	Only Baseline JPEG files are supported. Progressive JPEG files are not.	Use Baseline JPEG files (page 8).
	Only JPEG files with the following brightness/color difference ratios are supported: 4:4:4, 4:2:2, and 4:1:1.	Use JPEG files with the supported ratio (page 8).
	The JPEG file is too big.	Use JPEG files that are less than 5 MB (page 8).
The message “NO PLAY” appears on the display?	The disc is dirty.	Remove the disc and clean it (page 9).
Buttons on the DV-CP802 and remote controller don't work?	Power supply voltage fluctuations and other anomalies, such as static electricity, can interfere with normal operation.	Turn off the DV-CP802, wait five seconds, then turn it on again. If that doesn't resolve the issue, disconnect the power cord from the wall outlet, wait five seconds, reconnect it, then try again.
Buttons on the DV-CP802 work OK but those on the remote controller don't?	There are no batteries in the remote controller.	Install new batteries (page 16).
	The batteries are flat.	Replace with new batteries (page 16).
	The batteries are installed incorrectly.	Check the batteries and correct as necessary (page 16).
	You're not pointing the remote controller at the DV-CP802's remote sensor.	Point the remote controller at the DV-CP802's remote sensor (page 16).
	You're too far away from the DV-CP802.	Use the remote controller closer to the DV-CP802 (page 16). The remote controller has a range of approximately 16 ft. (5 meters).
	A strong light source is interfering with the DV-CP802's remote sensor.	Make sure that the DV-CP802 is not subjected to direct sunshine or inverter-type fluorescent lights. Relocate if necessary.
	If the DV-CP802 is installed in a cabinet with colored glass doors, the remote controller may not work reliably when the doors are closed.	Open the doors, or use a cabinet without colored glass.

### ■ Abnormal Behavior

The DV-CP802 contains a microcomputer for signal processing and control functions. In very rare situations, severe interference, noise from an external source, or static electricity may cause it to lockup. In the unlikely even that this should happen, unplug the power cord from the wall outlet, wait at least five seconds, and then plug it back in again. Alternatively, press and hold the STOP  button until “Reset” appears on the display (about 10 seconds).

### ■ Restoring the Default Settings

To reset the DV-CP802 to its factory defaults, turn it on and, while holding down the STOP  button, press the [STANDBY/ON] button. “Initialize” appears on the display. When the reset is complete, “Complete” is displayed, and the DV-CP802 enters Standby mode.

# Specifications

<b>Signal System</b>		NTSC
<b>Composite Video Output/Impedance</b>		1.0 V (p-p)/75 $\Omega$ negative sync, RCA/phono
<b>S-Video Output/Impedance</b>		Y: 0.7 V (p-p)/75 $\Omega$ negative sync, 4-pin mini DIN C: 0.286 V (p-p)/75 $\Omega$
<b>Component Video Output/Impedance</b>		Y: 1.0 V(p-p)/75 $\Omega$ PB/PR: 0.7 V (p-p)/75 $\Omega$ RCA/phono
<b>Frequency Response</b>	<b>DVD-Audio</b>	4 Hz–50 kHz (192 kHz)
	<b>DVD Linear Sound</b>	4 Hz–44 kHz (96 kHz)
		4 Hz–22 kHz (48 kHz)
	<b>Audio CD</b>	4 Hz–20 kHz (44.1 kHz)
<b>S/N ratio</b>		110 dB
<b>Audio Dynamic Range</b>		98 dB
<b>THD (Total Harmonic Distortion)</b>		0.005 % (1 kHz)
<b>Wow and Flutter</b>		Below threshold of measurability
<b>Audio Output (Digital/Optical)</b>		–22.5 dBm
<b>Audio Output/Impedance (Digital/Coaxial)</b>		0.5 V p-p/75 $\Omega$
<b>Audio Output/Impedance (Analog)</b>		2.0 V (rms)/600 $\Omega$
<b>Power Supply</b>		AC 120 V, 60 Hz
<b>Power Consumption</b>		21 W
<b>Standby Power Consumption</b>		0.6 W
<b>Dimensions (W x H x D)</b>		435 x 131 x 432 mm 17-1/8 x 5-3/16 x 17 inches
<b>Weight</b>		7.3 kg 16.1 lbs.
<b>Operation Condition Temperature</b>		5–35°C (4–95°F)
<b>Disc Compatibility</b>		DVD-VIDEO, DVD-AUDIO, CD, CD-R, CD-RW, SACD, MP3, DVD-R, DVD-RW, JPEG, VCD Disc that have not been property finalized may only be partially playable or not playable at all.

Specifications and features subject to change without notice.



## **ONKYO CORPORATION**

Sales & Product Planning Div. : 2-1, Nisshin-cho, Neyagawa-shi, OSAKA 572-8540, JAPAN  
Tel: 072-831-8023 Fax: 072-831-8124

### **ONKYO U.S.A. CORPORATION**

18 Park Way, Upper Saddle River, N.J. 07458, U.S.A.  
Tel: 201-785-2600 Fax: 201-785-2650 <http://www.onkyousa.com>

### **ONKYO EUROPE ELECTRONICS GmbH**

Liegnitzerstrasse 6, 82194 Groebenzell, GERMANY  
Tel: +49-8142-4401-0 Fax: +49-8142-4401-555 <http://www.onkyo.net>

### **ONKYO CHINA LIMITED**

Units 2102-2107, Metroplaza Tower I, 223 Hing Fong Road, Kwai Chung,  
N.T., HONG KONG Tel: 852-2429-3118 Fax: 852-2428-9039



I0404-1

SN 29343715

(C) Copyright 2004 ONKYO CORPORATION Japan. All rights reserved.



\* 2 9 3 4 3 7 1 5 \*



POST OFFICE  
WILL NOT  
DELIVER  
WITHOUT  
PROPER POSTAGE

# REGISTRATION DEPARTMENT

**ONKYO USA CORPORATION**

**18 PARK WAY  
UPPER SADDLE RIVER, NJ 07458 USA**

# ONKYO® Product REGISTRATION CARD

**Thank you** for purchasing our product. In order to protect your investment and to ensure that you receive information on new products, future updates or new releases, please register your product. You have two ways to do it.

**- Quick and Easy -**

Please visit our web site for your on-line registration at

<http://www.onkyousa.com>

Or please fill out this registration card and return it to us. Please remember to keep your receipt of your purchase for warranty and the other part of this card for future reference.

First Name Middle Initial Last Name

Address Apt/Suite

City State Zip

E-mail Address Phone Number

Age: 18 - 24 25 - 31 32 - 40 41- 60 61 + Male Female

Name and location of the Dealer you purchased the product from?

Date of Purchase Model Serial Number

Would you like to receive a product catalog every new model year?

Yes  No

How did you learn about Onkyo Products?

Advertisement  Review  Salesman  Friend  Other

Do you own other Onkyo Products? If yes, what is the model number

Yes  No

What other brands of stereo products or multi media products have you owned before?

What factors influenced your purchase decision?

Features  Sound  Quality  Design  Price  Recommendation

What other Audio/Video/multi media Equipment are you looking to purchase in the future?

When do you plan to purchase your next audio or multi media product?

3 Months  6 Months  9 Months  12 Months  24 Months

Other Comments/Suggestions about this product

## ONKYO USA CORPORATION

18 Park Way  
Upper Saddle River, NJ 07458 USA

Phone: 201-785-2600

Fax : 201-785-2650

<http://www.onkyousa.com>

## ***We offer Product Support/Customer Service 7 days per week***

In order to better assist you with your purchase, Onkyo has extended its customer service hours to a seven-day schedule. For questions, assistance, or comments Please call or e-mail us at :

**Phone: 1-800-229-1687**

**E-mail: Onkyo@onkyousa.com**

For information concerning product features and hookups, please include your name and daytime phone number along with the model number you are inquiring about for a response from a product specialist.

### Hours of Operation:

Mon – Fri 9:00am – 8pm (Eastern Standard Time)

Sat – Sun 10:00am – 4pm (Eastern Standard Time)

### **OBTAINING WARRANTY SERVICE:**

To obtain warranty service, take or ship your Onkyo product to an Onkyo authorized service center, together with a note describing your complaint and your copy of the dated purchase receipt. If you choose to ship your Onkyo product to an Onkyo authorized service center, all shipping arrangement must be made by you and all shipping charges and insurance must be fully prepaid. Any Onkyo product shipped in its entirety must be shipped in its original carton. Onkyo will pay all return shipping charges for Onkyo products that have been serviced under this warranty.

### **LIMITATIONS:**

Onkyo makes this warranty subject to the following limitations:

1. This Warranty is valid only within the territory of the United States of America. To be covered by this warranty the Onkyo product concerned must have been originally purchased and the person seeking warranty service must reside in one of the states of the United States of America or in the District of Columbia.
2. ONKYO SHALL HAVE NO LIABILITY WHATSOEVER FOR INCIDENTAL OR CONSEQUENTIAL DAMAGES. THE RESPONSIBILITY OF ONKYO UNDER THIS WARRANTY SHALL BE LIMITED TO THE REPAIR OF DEFECTIVE ONKYO PRODUCTS BY ONKYO OR ITS AUTHORIZED SERVICE CENTERS.
3. This warranty is valid only with respect to repairs effected by Onkyo or an Onkyo authorized service center.
4. ALL WARRANTIES OTHER THAN THE EXPRESS WARRANTY HEREIN CONTAINED INCLUDING BUT NOT LIMITED TO ANY IMPLIED WARRANTY OF MERCHANTABILITY OR FITNESS FOR A PARTICULAR PURPOSE ARE LIMITED IN DURATION TO THE APPLICABLE WARRANTY PERIOD SET FORTH ABOVE.

Some states do not allow limitations on how long an implied warranty lasts and some states do not allow the exclusion or limitation of incidental or consequential damages, so the above limitations or exclusion may not apply to you. This warranty gives you specific legal rights and you may also have other rights that vary from state to state.

Model \_\_\_\_\_

Serial No. \_\_\_\_\_

Customer's Name \_\_\_\_\_

Dealer's Name \_\_\_\_\_

Date of Purchase \_\_\_\_\_

### **ONKYO USA CORPORATION**

18 Park Way  
Upper Saddle River, NJ 07458 USA

Phone: 201-785-2600

Fax : 201-785-2650

<http://www.onkyousa.com>

SN. 29365090

## Onkyo USA Limited Warranty

**PLEASE RETAIN YOUR ORIGINAL BILL OF SALE. YOU WILL NEED TO PRESENT IT SHOULD YOU REQUIRE SERVICE UNDER THIS WARRANTY.**

Onkyo USA Corporation ( hereinafter referred to as Onkyo ) hereby warrants all Onkyo products sold by Onkyo or Onkyo authorized dealers in accordance with the following terms and conditions:

### WARRANTY PERIOD:

Receivers and Amplifiers	2 years Parts & labor
Tuners, Equalizers & Processors	2 years Parts & labor
Cassette Decks & Mini Discs	1 year Parts & labor
CD, DVD Players & Turntables	1 year Parts & labor
Multimedia Products	1 year Parts & labor
Mini Systems	1 year Parts & labor

### SCOPE OF WARRANTY:

From the date of original purchase and for the respective periods specified above, Onkyo agrees to repair at its sole expense, all Onkyo products purchased directly from Onkyo or an Onkyo Authorized Dealer, which are defective in material and/or workmanship.

### EXCLUSIONS:

This Warranty does not apply with respect to the following:

1. Defects or damage caused by accident, fire, flood, lightning or other acts of nature.
2. Defects or damage caused by abuse, misuse, negligence or failure to observe the instructions contained in the manual furnished at the time of original purchase.
3. Damage caused during shipment or handling.
4. Products purchased from anyone other than Onkyo or an Onkyo Authorized Dealer. If you are uncertain as to whether a dealer is authorized, please contact Onkyo's Customer Service Department or check the Dealer and Service Locator at our web site: <http://www.Onkyousa.com>
5. Products that have had their serial numbers altered or removed.
6. Products purchased in 'AS IS' condition.
7. Products that have been altered or repaired by anyone other than Onkyo or an Onkyo authorized service center in a manner that has affected their performance, stability or reliability.
8. Accessories attached to or to be used with Onkyo products, such as antennas, cables, etc.
9. Packing materials, batteries, antennas & cosmetic items.
10. Parts which have prescribed useful lives dependent upon the degree of their use, such as stylus, cassette heads, idler wheels, etc.
11. Installation & removal of Onkyo products.
12. Maintenance, cleaning or periodic check-ups.
13. Adjustments or alteration required for compatibility with conditions pertaining to foreign countries.
14. Products used continuously or for commercial applications. Onkyo products are intended for consumers' use and are not designed for continuous or commercial use. In the event that the products concerned have been used commercially or continuously, the warranty period is limited to 90 days from the date of purchase.

## NOTE

If returning this unit for any reason, please be sure to follow this "Packing Instructions".

Unit must be returned with all accessories such as remote controller, connecting cable, owner's manual, etc. Properly store them in the plastic accessory bag and place inside the carton box.

Please be sure the AC power cable is placed tightly wrapped behind the unit.

Reason for return

Does not work

Cosmetic defect

Detail of explanation

Please tape this sheet on the top of unit when you returning the unit to store.

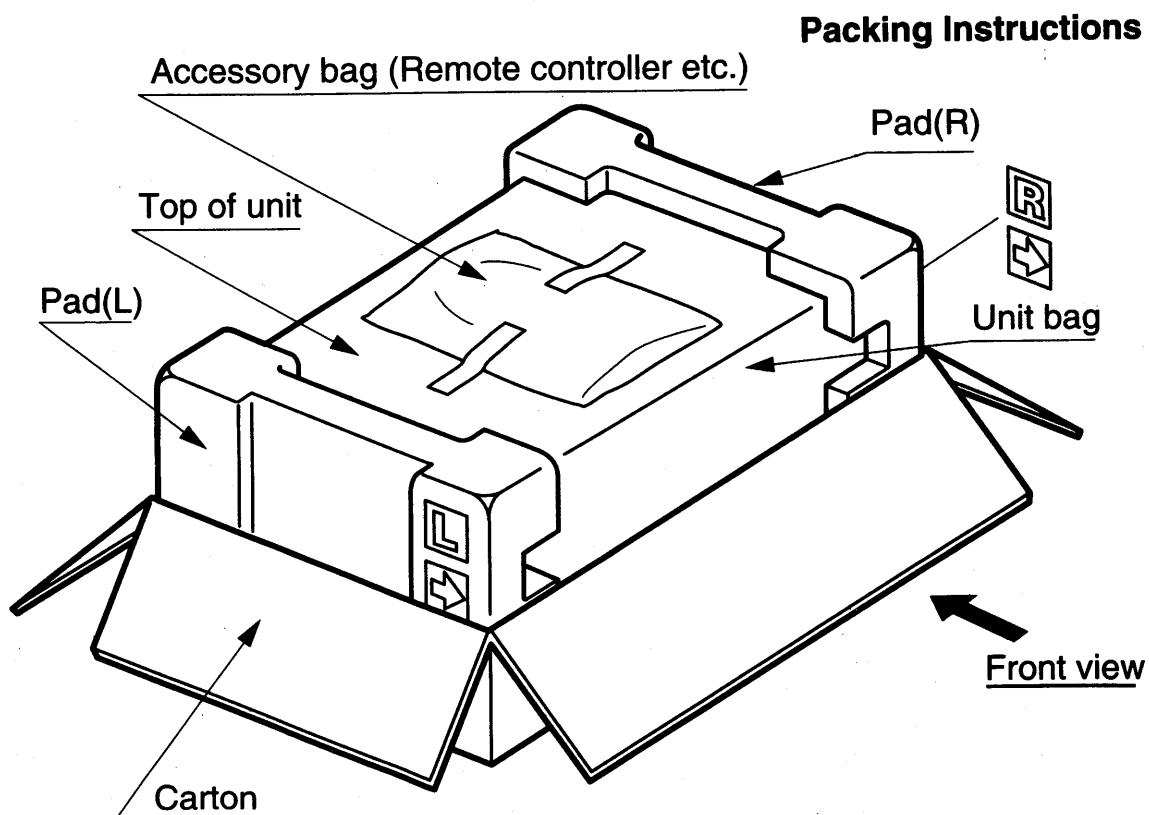

Please save this carton for future use

SN29355299  
107960