

**AFE325 Product Manual**

---

Purpose of this manual: To provide detailed installation and operation instructions; to give insights into how the machine works; to list possible causes for problems; and to suggest procedures for specific types of service.

The refrigeration system is either air or water cooled, and it uses R-134a as a refrigerant. The control system uses thermostat as a bin control and a water pressure switch as the water safety control.

The AFE325 is an ice maker that makes and stores flaked ice.

**Table of Contents**

- Specifications: . . . . . Page 2
- To The Installer: . . . . . Page 3
- For The Plumber . . . . . Page 4
- For The Electrician . . . . . Page 5
- Final Check List & Initial Start Up . . . . . Page 6
- User Operation . . . . . Page 7
- Component Location: Control Box . . . . . Page 8
- Refrigeration System Operation . . . . . Page 9
- Water System Operation: . . . . . Page 10
- Mechanical Operation . . . . . Page 11
- Sanitation and Cleaning . . . . . Page 12
- Maintenance And Cleaning . . . . . Page 13
- Maintenance: Air Cooled Condenser . . . . . Page 14
- Maintenance: Component Inspection . . . . . Page 15
- Service Diagnosis . . . . . Page 16
- Removal and Replacement . . . . . Page 18
- Water Seal & Bottom Bearing Replacement: . . . . . Page 19
- Refrigeration System . . . . . Page 20
- Gear Reducer Removal . . . . . Page 21
- Gear Reducer Rebuild . . . . . Page 22

***A Parts List and Wiring Diagram are located in the center of this manual, printed on yellow paper.***

# AFE325

## Specifications:

The finish for this machine is either painted enamel or stainless steel. No panel kit is available to convert an enamel machine to stainless steel.

Scotsman ice machines, like the AFE325, are designed to be installed indoors, in a controlled environment. The minimum and maximum operating conditions are:

- Minimum Air Temperature: 50°F.
- Maximum Air Temperature: 100°F.
- Minimum Water Temperature: 40°F.
- Maximum Water Temperature: 100°F.
- 60 Hz Voltage may vary between 104 and 126 volts.
- Water Pressure may vary between 20 and 80 psi.

Operating the machine outside these conditions constitutes misuse and voids the warranty.

Scotsman Ice Systems are designed and manufactured with the highest regard for safety and performance. They meet or exceed the standards of UL, NSF and CSA.

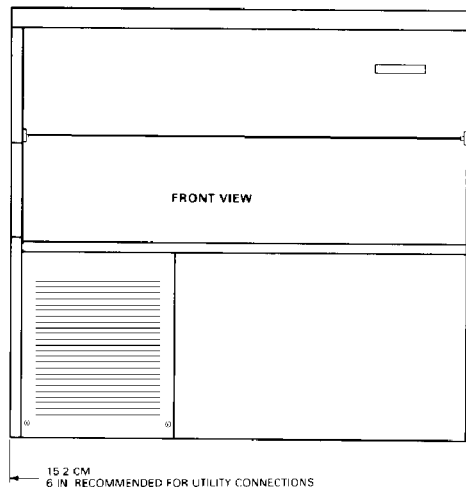

Scotsman assumes no liability or responsibility of any kind for products manufactured by Scotsman that have been altered in any way, including the use of parts and/or other components not specifically approved by Scotsman.

Scotsman reserves the right to make design changes and/or improvements at any time. Specifications and designs are subject to change without notice.

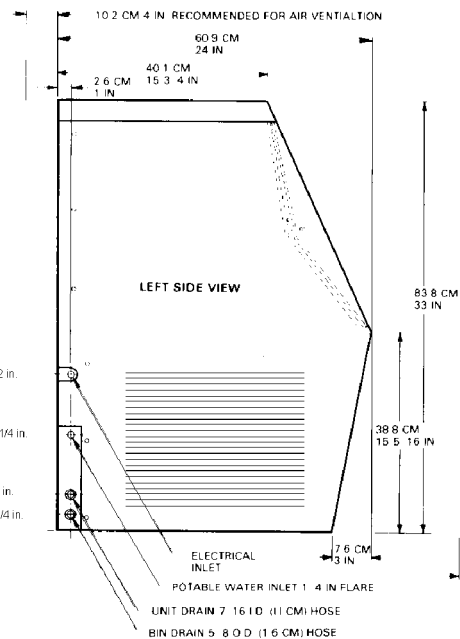
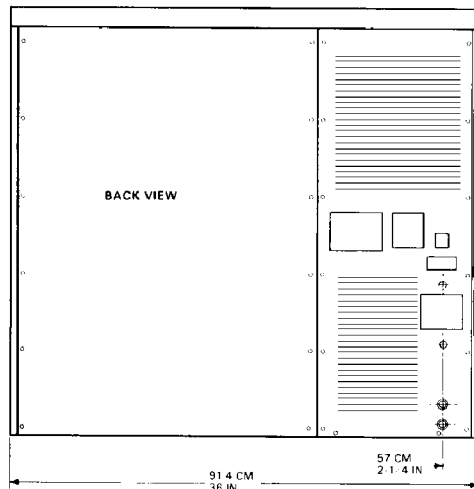

Model	Dimensions H' x W" x D"	Basic Electrical	Condenser Type	Min. Circ. Ampacity	Max. Fuse Size	Refrigerant Charge (R-134a)
AFE325AE-1A	33 x 36 1/16 x 24	115/60/1	Air Cooled	10.7	15	11 oz.
AFE325AE-6A	33 x 36 1/16 x 24	230/50/1	Air Cooled	5.4	15	11 oz.

**To The Installer:**

A professional installation of any product is critical to the long term satisfaction of the user. The AFE325 is designed to be installed indoors, near a drain. Determine the location from the anticipated use and any options planned for.

This air cooled machine blows air out the back and left sides of the cabinet. Do not install the machine where the air flow might be blocked.

The machine will require electrical power, water and a drain. Follow all local codes. Rough in the utilities before placing the machine into position (see For The Electrician and For The Plumber).

After uncrating, install the legs or optional casters. If the building's drain is a floor drain near the machine, the cabinet can be placed on the floor and sealed around the edges.

Place the cabinet in the place where it will be operating. Note that the electrical and water connections need to be made.

Level the unit front to back and left to right.

**Water Quality:**

The quality of the water supplied to the machine will directly affect the purity of the ice and the reliability of the machine. While the condition of the water supplied to a building is normally out of the control of the user, water can be treated at the point of use.

There are two major types of water impurities: suspended solids (those that are carried along with the water and may be filtered out) and dissolved solids (those that are part of the water and have to be treated). A water filter is always a good idea, but does require regular maintenance to change the cartridge. In some water conditions, water treatment may be required. Generally this means a polyphosphate feeder of some kind. Water softeners are not recommended for the AFE325.

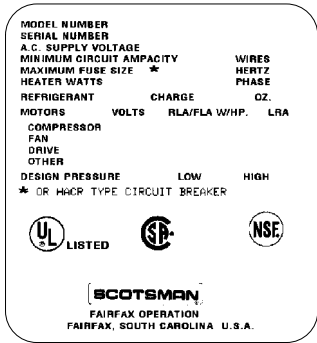

**Nameplate Is Located On The Back Panel.**

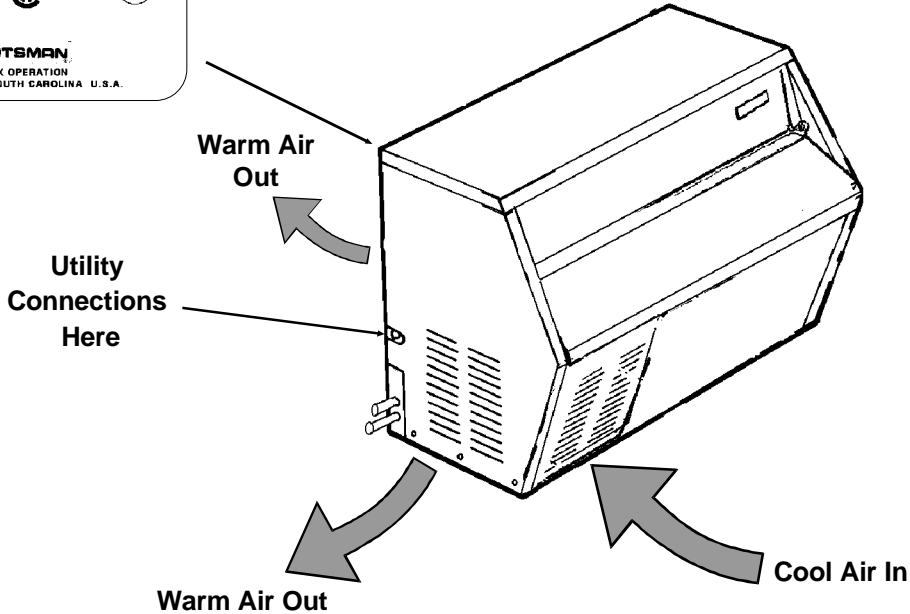

# AFE325

## For The Plumber

---

**Drains:** The ice maker requires a gravity drain for the reservoir overflow and bin drain. The pitch on the drain tubes must be at least 1/4 inch fall per foot of horizontal run. On long horizontal runs, a vent at the back of the cabinet will improve draining, and is recommended.

### Water supply:

Connect cold, potable water to the machine. A hand valve near the location is recommended. A water filter is also a good idea.

Follow all local codes.

There are two drains and one water inlet connection to make.

The drains are: a copper bin drain tube; and a rubber reservoir overflow tube.

The water inlet connection is a 3/8" male flare.

Route a drain line to the reservoir overflow drain hose. Route a separate drain to the bin drain tube.

Route the inlet water line to the fitting on the corner post.

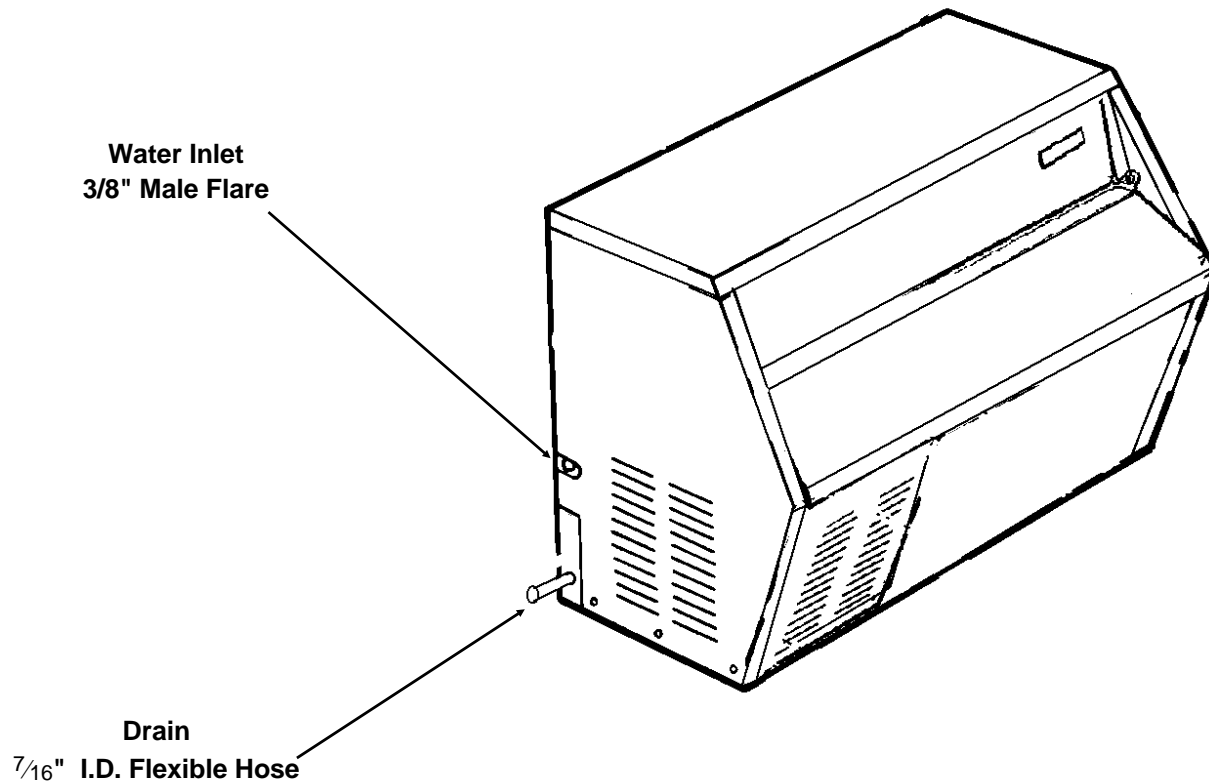

# For The Electrician

Electrical connections:

**Follow All Local, State & National Codes**

Check the nameplate for voltage and current requirements. An electrical cord is not supplied. Connect the AFE325 to a separate electrical circuit. Wiring to the machine must conform to all codes. A licensed electrician may be required in some situations. The electrical connection is made in the control box inside the machine.

**This unit must be grounded.**

Route the electrical power cord thru the corner post to the control box inside the cabinet.

To make the electrical connection, remove the following parts:

- Top panel
- Bin door
- Rubber moulding
- Left moulding cover
- Left track
- Upper front panel
- Upper baffle
- Left side panel
- Front louvered panel
- Control box cover

If the machine will be started up later, after making the electrical connections, replace all panels.

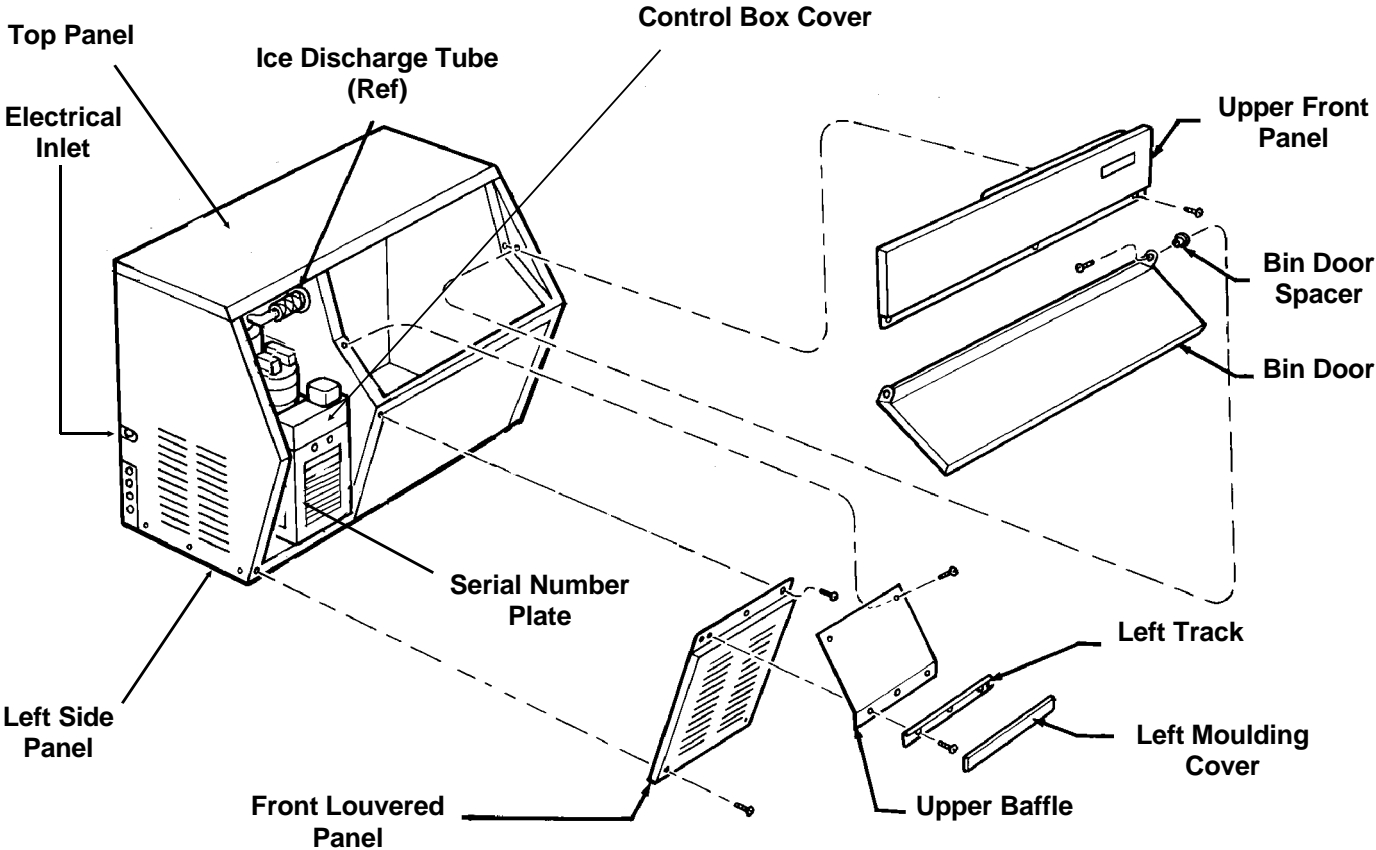

# AFE325

## Final Check List & Initial Start Up

---

1. Is the machine located indoors where the temperature limitations are not exceeded?
2. Is there at least 6" clearance on the left side and the back of the cabinet for adequate air flow?
3. Is the water supply adequate, and has a shut off valve been installed?
4. Is the cabinet level?
5. Have all of the electrical and drain connections been made?

**Note: For High Altitude Installations an Altitude Adjustment May Be Required:  
(11-0354-01, 20 Ranco brand bin thermostats only)**

Adjustment	Altitude (ft. above seal level)	Amount of adjustment from factory setting
Range Screw CW	2,000	35 <sup>o</sup>
	4,000	90 <sup>o</sup>
	6,000	145 <sup>o</sup>
	8,000	190 <sup>o</sup>

### Initial Start Up

1. Remove the following parts:
  - Top panel
  - Bin door
  - Rubber molding
  - Left molding cover
  - Left track
  - Upper front panel
  - Upper baffle
  - Left side panel
  - Front louvered panel
  - Control box cover
  - the top panel.
2. Open the water shut off valve.
3. Watch the water fill the reservoir. Check that it flows in and fills the reservoir near to the mark molded into the side of the reservoir. Check that the float shuts off the water flow when the tank is full. Check for leaks. Tighten hose clamps as needed.
4. Plug the unit in or switch on the electrical power.
5. Switch the master switch to ON.
6. Let the machine operate, listen for any unusual noises. If needed, reposition tubing & panels to eliminate vibration.

After the unit has been operating for about 10 minutes, there should be enough ice in the bin to test the bin thermostat.
7. Pick up some ice and hold it up against the bottom of the ice thermostat tube.
8. After a short time the bin thermostat should switch the machine off.
9. Pour water into the bin and check that the drain does not leak but drains the water rapidly.
10. Replace all panels.
11. Explain to the user the maintenance requirements and operation of the machine.
12. Fill out the Warranty Registration and Customer Evaluation form. Mail it to Scotsman.
13. Leave the service manual with the owner/user and explain who should be called if service is needed.

## User Operation

---

The AFE325 is an automatic ice flaked machine. All it requires is cool air, clean water, a drain, and an adequate supply of electrical power.

The user must regularly sanitize and clean the machine.

### Component Location & Function

**Evaporator.** This is a vertical cylinder full of water and refrigerated. Also in the cylinder is a slowly rotating auger. The auger forces the ice up the evaporator walls and compresses it at the top. The resulting flaked ice then falls by gravity into the ice storage bin.

**Water Reservoir.** The water reservoir contains the inlet float valve and the water level sensor. The float valve controls the flow of water into the reservoir.

**Water Pressure Cut Out Switch:** The purpose of this switch is to stop the ice maker if the water supply fails.

**Condenser.** The AFE325 uses an air cooled condenser. It blows air out, away from the fan motor. The heat removed from the water is exhausted from the condenser.

**Compressor.** The refrigeration system compressor provides the force to move the refrigerant around the system.

**Auger Drive.** The auger drive is a direct drive gear reducer.

# AFE325

## Component Location: Control Box

---

**Auger Delay Pressure Control:** This pressure switch, connected to the low side of the refrigeration system, controls the auger drive motor.

**On-Off switch:** This toggle switch shuts off the machine. It is not a complete disconnect.

**Bin Thermostat:** This thermostat turns the machine on and off in response to changes in temperature of the capillary tube. It opens at 35<sup>0</sup> F. and closes at 45<sup>0</sup> F. The capillary tube is mounted on the inside of the ice chute.

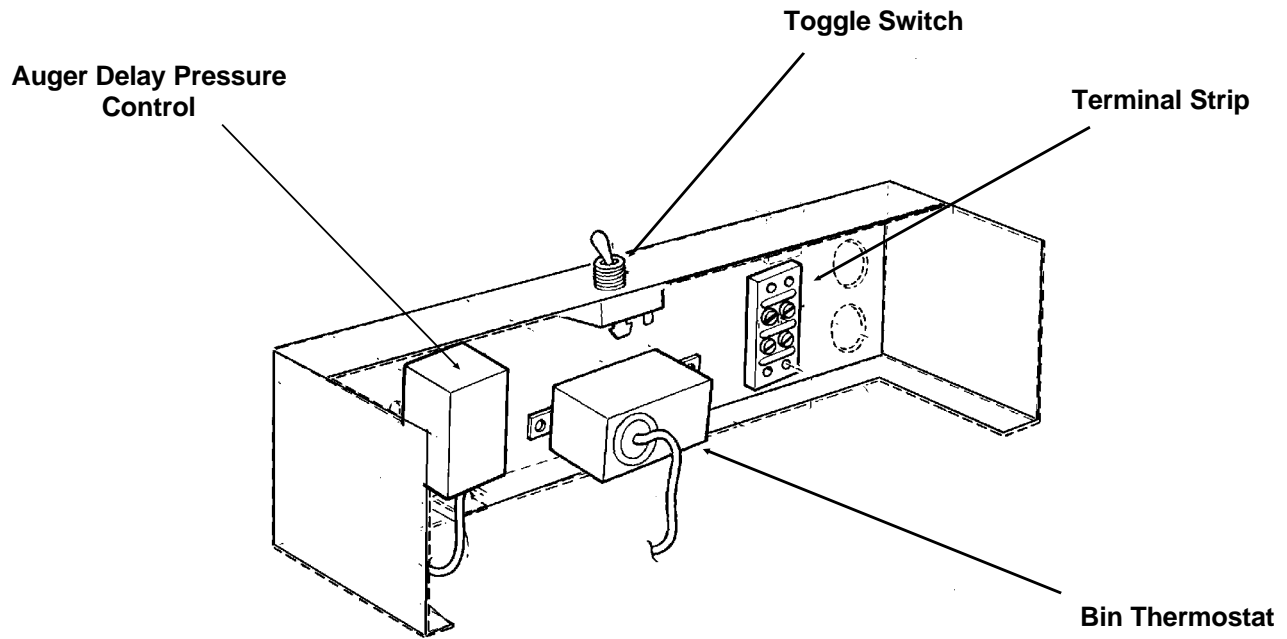

**Control Box**



# Refrigeration System Operation

The AFE325 uses a forced draft air cooled condenser, capillary tube and hermetic compressor. The system uses R-134a as a refrigerant. High pressure, high temperature refrigerant is forced thru the condenser where it loses enough heat to condense. The high pressure liquid refrigerant then passes thru the capillary tube which causes a pressure drop in the evaporator. As the high pressure liquid refrigerant moves into the evaporator's area of low pressure, the warm water and low pressure cause the refrigerant to evaporate and absorb heat from the metal walls of the evaporator. After the refrigerant has flowed thru the evaporator it goes back to the compressor thru the suction line as a low pressure vapor. At the compressor the cycle is repeated. The AFE325 uses a low side pressure control as a safety, it will shut the system down if the suction pressure is too low for reliable operation.

### System Characteristics:

**Note:** *This ice machine has a sealed refrigeration system. Tap into the system ONLY when it's absolutely necessary. After tapping in, recovery, repair, evacuation and recharging, the piercing valve must be removed and the system re-sealed.*

Typical Low Side Pressure\*: 7 - 10 PSIG

Typical Discharge Side Pressure\*: 130 - 165 PSIG

Typical Auger Drive Motor Amps (60 Hz): 2.8 - 3.1

Auger Drive Output RPM (60 Hz): 9.6

System Refrigerant Charge: 11 Ounces of R-134a

\* Pressures depend upon air and water temperatures. Numbers listed are for 70°F. air/50°F. water and 90°F. air/70°F. water.

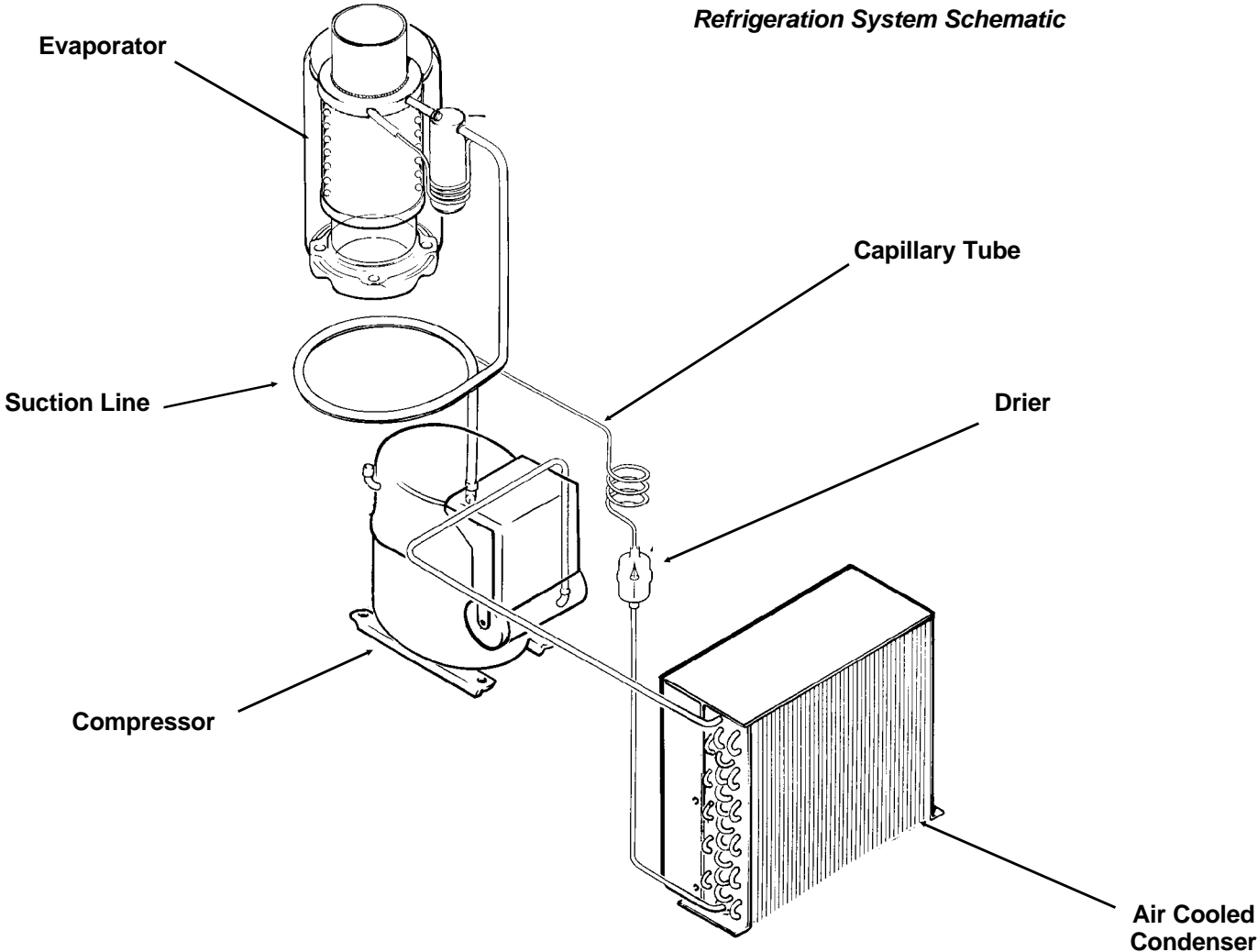

# AFE325

## Water System Operation:

The water system consists of a float valve and reservoir. The water level in the reservoir tank is the same level as that inside the evaporator. Building water supply flows to the float valve and the float valve opens to add water to the reservoir as water flows out to the evaporator.

Inside the evaporator there is a water seal. This seal is the type that has a rotating half and a stationary half. The area where the two seals touch are smooth flat surfaces. When the auger is installed in the evaporator, it forces the rotating half of the seal against the stationary half. The stationary half is spring-loaded and provides a firm pressure against the auger portion of the seal.

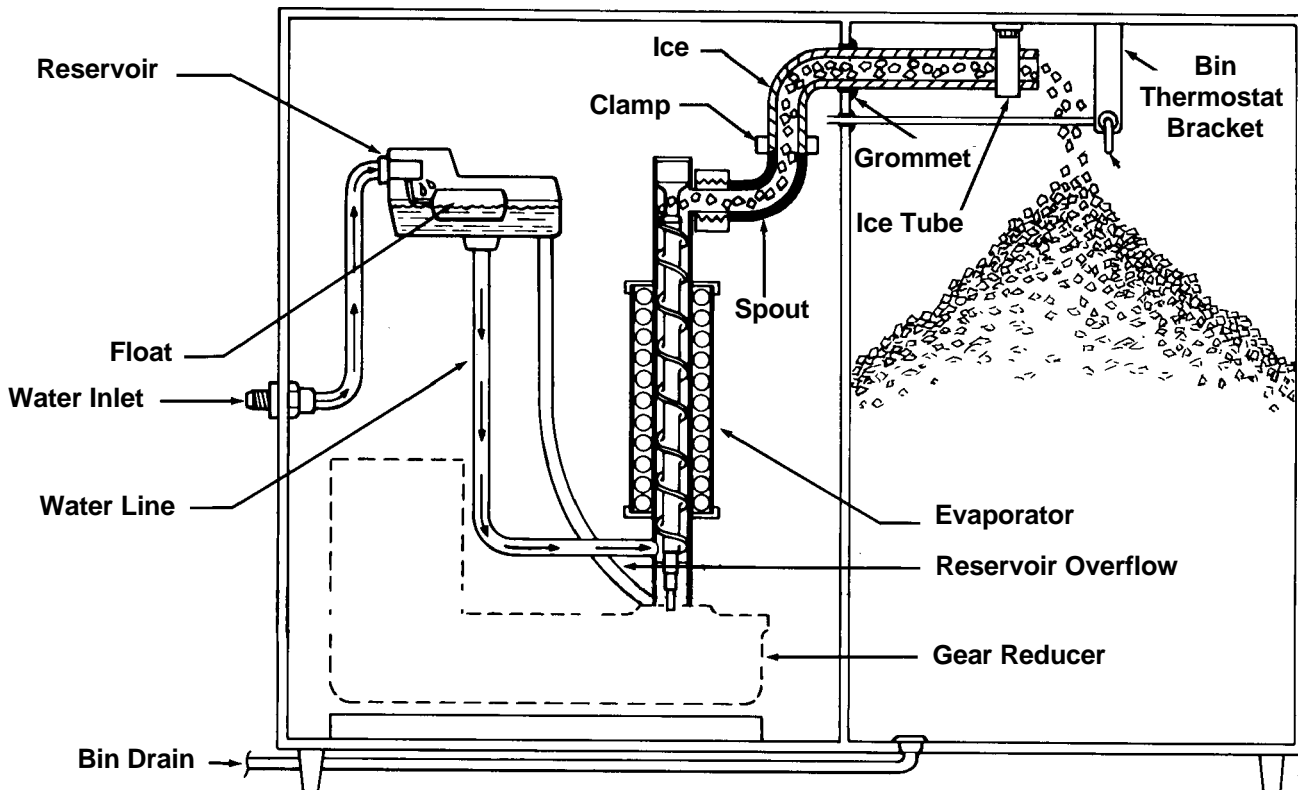

*Water System Schematic*

## Mechanical Operation

---

### ELECTRICAL SEQUENCE

There are two circuits in the AFE325: one is a series circuit with several switches connected in series to the compressor. The other is a parallel branch of the series circuit, controlling the gear drive motor.

- The series circuit begins at the terminal strip in the control box. From there, the line side power is connected to the Master Switch.
- When the master switch is closed, the power is then connected to the Spout Switch. This switch, located on the top of the ice chute, is closed unless the ice chute has overflowed with ice, it is a manual reset.
- The line side power is also connected, in a parallel circuit, to terminal 1 of the Auger Delay pressure control. This pressure control, connected to the low side of the refrigeration system, is designed as a by-pass circuit to the auger drive motor whenever the low side refrigerant pressure is at its normal ice making range. At start up, the contacts between terminals 1 and 2 are open. The line side power does not pass any further through the auger delay pressure control, until the compressor starts, and the low side pressure drops.
- The next control the power is connected to is the Low Water Pressure Control. This switch is designed to open should the water pressure to the machine drop too low.
- The next control is the Bin Thermostat. It is closed when there is no ice on the portion of the control inside the ice bin. It is open when there is ice on the portion of the control inside the ice bin. Closing of the bin thermostat begins the process of making ice, because the line side power now goes to the compressor, gearmotor, and if air cooled, the fan motor.
- Power is initially connected to the gearmotor through contacts 3 and 2 of the auger delay pressure control. This causes the auger motor to start and run. At the same time, if the centrifugal switch on top of the gearmotor closes (meaning the motor is at full speed) the compressor is connected to the neutral side of the power supply, and the compressor begins to run.

- As the compressor runs, the low side or suction pressure begins to fall, when it reaches a preset point, the contacts within it move, opening 3 and 2, then closing 1 and 2. The power for the gearmotor is then connected to a point in the series circuit ahead of the low pressure control, the low water pressure control and the bin thermostat, so that if any of these open, the gearmotor will continue to run, pushing ice out of the evaporator.

The refrigeration system uses a hermetic compressor (specifically designed for R-134a), forced draft air cooled condenser, capillary tube and vertical flaked ice evaporator. Inside the evaporator is a slowly rotating auger. The auger is supported by bearings at each end, and there is a face-type water seal above the bottom bearing. The auger is driven by a 1/10 HP direct drive gear reducer. The auger drive motor has a speed operated switch on it that will keep the compressor from operating if the auger motor is not turning at full speed.

Water flows from the building supply to the reservoir. Water from the reservoir is used to make ice.

The bin and reservoir overflow have separate drains.

# AFE325

## Sanitation and Cleaning

### Maintenance:

The water and ice making systems will need to be periodically sanitized and de-mineralized. The air cooled condenser will also need to be kept clean. Detailed instructions are provided on page 14.

Schedule the sanitation, cleaning and de-mineralization on a regular basis to keep the ice clean and the machine operating efficiently

### Water System:

The water system requires periodic sanitation and de-mineralization.

### Schedule & Responsibility:

A Scotsman Ice System represents a sizable investment of time and money in any company's business. In order to receive the best return for that investment, it MUST receive periodic maintenance.

It is the USER'S RESPONSIBILITY to see that the unit is properly maintained. The following is a list of recommended maintenance that will help keep the machine running with a minimum of problems.

Maintenance and Cleaning should be scheduled at a minimum of twice per year.

### ICEMAKING SYSTEM: In place cleaning

1. Check and clean any water treatment devices, if any are installed.
2. Remove screws and remove the top and front panels.
3. Move the ON - OFF switch to OFF.
4. Open the door to the ice storage bin, and remove the ice.
5. Remove the cover to the water reservoir and block the float up.
6. Drain the water reservoir and freezer assembly.
7. Prepare the cleaning solution: Mix 4 ounces of Scotsman Ice Machine Cleaner with 1 1/2 quarts of hot water. The water should be between 90-115°F.

8. Slowly pour the cleaning solution into the water reservoir until it is full. Wait 15 minutes, then switch the master switch to ON.

9. As the ice maker begins to use water from the reservoir, continue to add more cleaning solution to maintain a full reservoir.

10. After all of the cleaning solution has been added to the reservoir, and the reservoir is nearly empty, switch the master switch to OFF.

11. After draining the reservoir, as in step 6, wash and rinse the water reservoir.

12. Go thru steps 13 - 18 to sanitize the ice machine water system.

13. Mix two gallons of sanitizer solution. Use an approved sanitizer.

A possible sanitizer solution may be obtained by mixing two gallons of warm (90-115°F.) potable water with 1 ounce of household bleach.

14. Slowly pout the sanitizer solution into the water reservoir until it is full, then switch the master switch to ON.

15. As the ice machine uses water from the reservoir, continue to add sanitizing solution to keep the reservoir full.

16. After 1/2 of the sanitizer solution has been added to the reservoir, and the reservoir is nearly empty, switch the master switch OFF.

17. Drain the reservoir and thoroughly wash the interior of the reservoir and cover with sanitizer solution.

18. Remove the block from the float in the water reservoir.

19. Switch the master switch to ON.

20. Continue ice making for at least 15 minutes, to flush out any cleaning solution. Switch the master switch OFF.

**DO NOT USE any ice produced from the cleaning solution. Be sure no ice remains in the bin.**

21. Remove all ice from the storage bin.

22. Add warm water to the ice storage bin and thoroughly wash and rinse all surfaces within the bin.

23. Sanitize the bin interior by thoroughly washing all interior surfaces of the bin with the balance of the sanitizer solution.

24. Switch the master switch ON.

25. Replace the top and the front panels.

**Scotsman Ice Machine Cleaner contains acids. These compounds may cause burns.**

If swallowed, DO NOT induce vomiting. Give large amounts of water or milk. Call Physician immediately. In case of external contact, flush with water.

**KEEP OUT OF THE REACH OF CHILDREN.**

**⚠ WARNING**

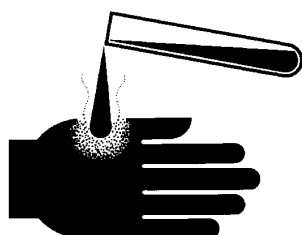

## Maintenance and Cleaning

In some areas, the water supply to the ice maker will contain a high concentration of minerals, and that will result in an evaporator and auger becoming coated with these minerals, requiring a more frequent removal than twice per year. If in doubt about the condition of the evaporator and auger, the auger can be removed so the parts can be inspected.

Note: Water filters can filter out suspended solids, but not dissolved solids. "Soft" water may not be the complete answer. Check with a water treatment specialist regarding water treatment.

**For more information on removal of these parts, see REMOVAL AND REPLACEMENT.**

### To Inspect The Top Bearing:

1. Disconnect electrical power and shut off the water.

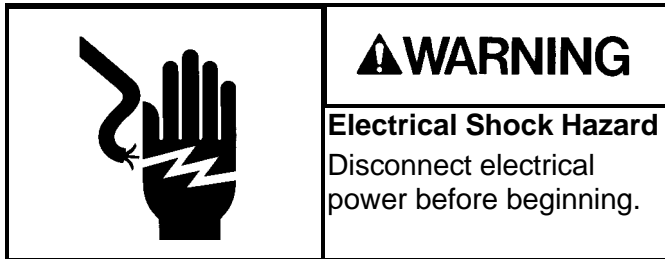

2. Remove the two screws from the spout at the side of the evaporator. Pull the spout away from the evaporator.
3. Remove screw holding spout plate to evaporator.
4. Remove the snap ring and cap, and remove the bolt from the ice breaker and auger assembly to separate the ice breaker assembly from the auger. Pull the ice breaker with bearing out of the top of the evaporator: the auger should stay in the evaporator.  
The bearings may be inspected for rust, wear, and roughness. Reverse to reassemble.

### To Inspect the Auger:

1. Disconnect electrical power and shut off the water.
2. Remove the two screws from the spout at the side of the evaporator. Pull the spout away from the evaporator.
3. Remove screw holding spout plate to evaporator.
4. Pull up on cap hook located in the top of the freezer assembly to remove the ice breaker assembly, auger, and the top portion of the water seal.
5. Inspect the auger and the water seal. Clean the auger of any mineral build up. Scotsman Ice Machine Cleaner and a scouring pad work well to clean the auger. **DO NOT USE** steel wool.
6. Replace the water seal, see the instructions under "Removal and Replacement".

# AFE325

## Maintenance: Air Cooled Condenser, Bearings

---

1. Disconnect electrical power.

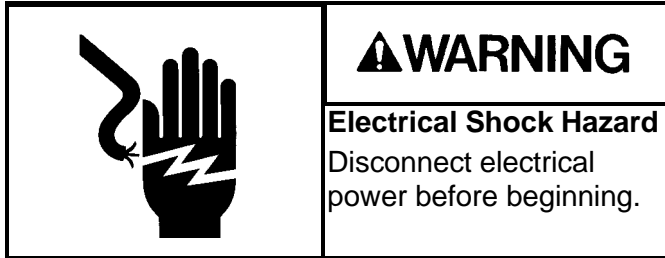

2. Remove front louvered panel
3. Wipe the lint off the front of the condenser. If needed, clean the interior of the condenser.
4. Use pressurized air to blow the lint from the inside of the condenser. A vacuum cleaner hose should pick up most of the dust. Check for interior dirt. If needed, use coil cleaner to de-grease the condenser.
5. Replace all panels and reconnect electrical power.

### Auger and Bearing Inspection

While in most areas regular in-place cleaning with Scotsman Ice Machine Cleaner will be adequate to keep the interior of the evaporator free of excessive mineral build up, some water conditions may require more intense methods. In addition, the auger bearings require physical inspection to determine that they are not wearing. This physical inspection is recommended twice per year for the top bearing and once per year for the auger and both bearings.

Whenever the auger is removed, replacement of the water seal is recommended.

If a bearing requires replacement, the other bearing must also be replaced.

1. Unplug or disconnect electrical power.
2. Shut off the water supply.
3. Remove top panel.
4. Remove right side panel.
5. Drain the evaporator and reservoir.
6. Remove the two screws from the spout at the side of the evaporator.
7. Remove screw holding spout plate to evaporator.
8. Remove spout.
9. Pull up on the pull ring to remove the auger. If it is difficult to pull:
  - A. Remove the breaker cover by taking the snap ring out.
  - B. Unscrew the auger bolt.
  - C. Use threaded rod or a slide hammer puller and screw into the auger, slide the weight up against the stop to remove the auger.

If the auger still will not move, bearing replacement is mandatory. See Bearing Removal and Replacement.

## Maintenance: Component Inspection

---

**Auger.** The auger is made of stainless steel. It has a polished surface that may be very shiny or dull. Allow the auger to dry, if mineral scale is found on the auger's surface, clean off the auger with ice machine cleaner and a scrubbing pad.

Remove the water seal and clean off the shoulder of the auger.

**Bearings:** The top bearing should spin freely with no rough spots. If it feels rough when spun by hand, replace it. There should be minimal rust or dirt. If in doubt, replace the bearing.

The bottom bearing must be removed from the evaporator when replacing the water seal.

Remove the three bolts holding the evaporator to the gearmotor adapter and lift the evaporator up slightly. Tap the water seal and bottom bearing out from the top down. Check the bottom bearing the same way as the top.

Replace the water seal and install a new bearing set if needed.

### To replace the water seal:

1. Remove old rotating half from the auger. Clean the mounting area.
2. Place a bead of food grade sealant (such as Scotsman part number 19-0529-01) onto the shoulder of the auger where the rotating half of the water seal will be installed.
3. Wash the new seal in water. While wet, slip it onto the bottom of the auger, rubber side toward the auger. Push up until seated against the sealant. Do not allow any sealant to come into contact with the face of the seal.
4. Wash the stationary half the water seal with water. Slip it up into the bottom of the evaporator until the bottom of the seal is inside the evaporator about 1/4".
5. Push the bottom bearing against the water seal until the bottom bearing is inside the evaporator about 1/16".
6. Replace the evaporator on the adapter, and re-attach the stand using the original bolts.
7. Attach the auger to the top bearing and breaker.
8. Return the auger to the evaporator and slide it down until the splines touch the coupling.
9. Rotate the auger until the coupling splines align with the auger.

10. Push the auger down, and rotate the breaker until the screw hole lines up with the pilot hole in the evaporator.

11. When the auger is completely seated, reinstall the breaker screws.

12. Replace spout and rubber top.

13. Switch on the water supply.

14. Observe operation. The unit should make minimal noise while producing ice. Catch first 2 minutes of ice and discard it.

15. Replace all panels.

### Coupling

Use the grease zerk on the side of the coupling to add grease once per year.

That concludes normal maintenance. If the fan motor has an oil plug, it may be oiled after 10 years of operation.

# AFE325

## Service Diagnosis

Problem	Possible Cause	Probable Correction
No ice, nothing is operating.	Unit has no power.	Restore power. If breaker or fuse tripped, check for overloaded circuit or short circuit.
	Master switch off	Switch unit on. Determine why switch was off.
	No water (water safety switch open)	Restore water supply. Check filters or strainer.
	Spout switch open	Check bin thermostat for failure to open and shut off machine. Check spout for internal pitting.
	Bin thermostat open	Check air temp, it must be over 50°F. for thermostat to start unit.
	Auger drive motor will not start.	Check windings of auger drive motor. Check for seized gears.
	Auger delay switch open	Replace auger delay.
No ice, auger drive is operating.	Centrifugal switch is open.	Check/replace switch
	Compressor will not start.	Check voltage.
		Check start relay
		Check start capacitor
	Check compressor	
Lack of refrigerant	Check system. Locate leak. Recover remaining refrigerant, replace drier, evacuate to 200 microns and weigh in the system charge.	
No condensing	Fan not turning, or blade broken.	
Unit will not shut off.	Bin thermostat stuck closed.	Replace thermostat.
Auger motor will not shut off.	Auger delay stuck	Replace auger delay
	System pressures too low to switch auger delay off.	Check pressures. If low, check for restriction or leak.



**Service Diagnosis**

<b>PROBLEM</b>	<b>POSSIBLE CAUSE</b>	<b>PROBABLE CORRECTION</b>
Unusual noise	Mineral scale in evaporator	Clean water system with ice machine cleaner.
	Auger coupling dry	Grease coupling
	Auger coupling worn	Replace coupling and adapter stand.
	Bearings worn	Replace bearings and water seal.
	Gearmotor loose on frame	Tighten bolts, check grommets
	Low water level	Check water level in reservoir
	Tubing vibrating	Check tubing for contact
	Tooth on a gear missing	Check gears in auger drive
	Compressor too loud	Replace compressor
	Gear noise	Check gearmotor for oil leak
Water leaks from cabinet	Evaporator water seal worn or cracked	Replace seal and bearings
	Tubing to evaporator leaks	Replace tubing/fittings
	Drain leaks	Check drain tubes and fittings
	External drain restricted	Clean out drain
No refrigeration	Gearmotor does not turn	Check motor
	Centrifugal switch does not close	Check switch
	Fan motor does not turn	Check fan motor
	Lack of refrigerant	Add refrigerant, if problem is reduced, locate leak and repair it.
	Compressor does not pump	Check/replace start capacitor
Check/replace start relay		
Check/replace compressor		

# AFE325

## Removal and Replacement

---

### Water System

The water system consists of the reservoir and inlet water valve.

Reservoir.

1. Shut off the water supply.
2. Remove the top panel.
3. Remove the left side panel.
4. Drain the water reservoir and evaporator.
5. Disconnect inlet and outlet tubes from the reservoir.
6. Remove screws holding reservoir to its mounting bracket.
7. Remove reservoir from the machine.
8. Reverse to reassemble.

### Bearings, Water Seal and Auger

1. Disconnect electrical power.

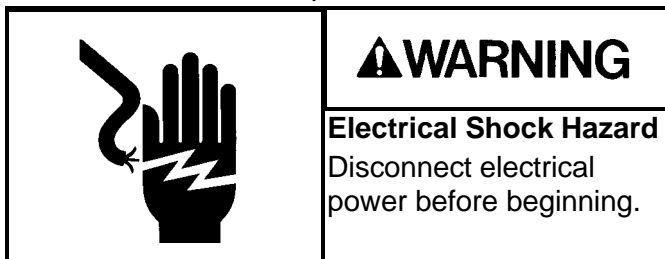

2. Shut off the water supply.
3. Remove the top panel.
4. Remove the front and side panels.
5. Drain the reservoir and evaporator.
6. Remove rubber cap from the top of the evaporator.
7. Remove the two bolts from the spout on the side of the evaporator.
8. Remove the screw holding the bearing retainer to the evaporator.
9. Pull up on the ring to lift the auger out of the evaporator.

If the auger will not lift out:

1. Remove snap ring holding bearing cover to breaker.
2. Remove bearing cover.
3. Unscrew bolt holding bearing to auger.

4. Thread in a threaded rod and weight or slide-hammer puller into the auger.

5. Use the threaded rod & weight or slide hammer puller to remove the auger.

Or

1. Remove three cap screws holding evaporator to the adapter stand.

2. Lift evaporator up slightly and tip the bottom out to expose the splined end of the auger.

3. Use a plastic mallet or dead-blow hammer to tap the bottom of the auger and force the auger up. Do NOT damage the splines of the auger or the auger will have to be replaced.

If the auger is "frozen" to the bottom bearing, do not force the bottom bearing thru the evaporator.

### Replacement

1. Replace the bearings and water seal. Replace the auger if the splines are damaged. Replace the evaporator if more than 1/3 of the vertical rifle grooves are gone. Sand or hone and sand the inside of the evaporator if mineral build up is heavy.

Top Bearing Replacement:

If the inner race is secure, use an arbor press to push the top bearing out of the breaker. If the inner race has separated from the bearing, replace the breaker.

Insert a new bearing in the breaker.

Replace the "O" ring in the breaker.

Push the bearing in, push only on the outer race.

## Water Seal & Bottom Bearing Replacement:

1. Remove old rotating half from the auger. Clean the mounting area.
2. Place a bead of food grade sealant (such as Scotsman part number 19-0529-01) onto the shoulder of the auger where the rotating half of the water seal will be installed.
3. Wash the new seal in water. While wet, slip it onto the bottom of the auger, rubber side toward the auger. Push up until seated against the sealant. Do not allow any sealant to come into contact with the face of the seal.
4. Wash the stationary half the water seal with water. Slip it up into the bottom of the evaporator until the bottom of the seal is inside the evaporator about 1/4".
5. Push the bottom bearing against the water seal until the bottom bearing is inside the evaporator about 1/16".
6. Replace the evaporator on the adapter, and re-attach the stand using the original bolts.
7. Attach the auger to the top bearing and breaker.
8. Return the auger to the evaporator and slide it down until the splines touch the coupling.
9. Rotate the auger until the coupling splines align with the auger.
10. Push the auger down, and rotate the breaker until the screw holes line up with the pilot holes in the evaporator.
11. When the auger is completely seated, reinstall the breaker screws.
12. Replace permagum and foam top.
13. Switch on the water supply.
14. Check bin cover for electrical grounds and switch on the electrical power.
15. Observe operation. The unit should make minimal noise while producing ice. Catch first 2 minutes of ice and discard it.
16. Replace the bin cover and all panels.

### Evaporator

Follow all steps to remove the auger & bearings.

1. Recover the refrigerant charge. Note: The refrigeration system must not remain open for more than 15 minutes.
2. Unsweat suction and cap tube connections.
3. Remove evaporator from the machine.
4. Remove old drier.
5. Install new evaporator.
6. Install new HFC type drier.

Note: The refrigeration system uses an HFC type refrigerant and MUST use an HFC type drier.

7. Braze the drier connections, cap tube and suction line together.
8. Evacuate to 200 microns, and weigh in the system charge.

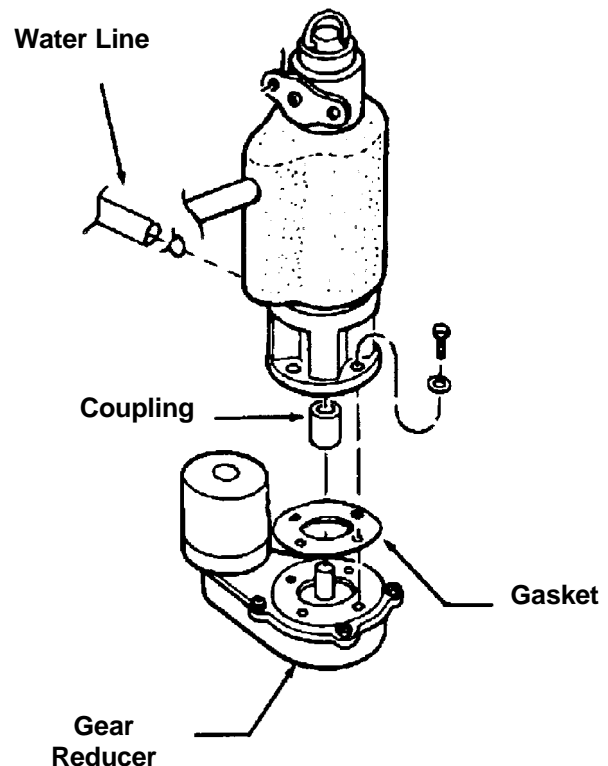

# AFE325

## Refrigeration System

This ice machine uses R-134a as the refrigerant. This refrigerant has no chlorine, and therefore requires polyolester type refrigerant oil. This oil requires specific service procedures.

### Service Recommendations:

This ice machine has a sealed refrigeration system. It must not be tapped into unless absolutely necessary. If access is required, tap into the "process" tubes (dead-end tubing that has been pinched-off and brazed shut).

After recovery, repair, evacuation and re-charging, remove the piercing valves:

1. Pinch off the process tube below the valve.
2. Remove the valve.
3. Braze the end of the tube shut.

A HFC type liquid line drier is required. "Standard" driers may not take out enough moisture and may affect the oil additives.

The time that the refrigeration system is open to the air must not exceed 15 minutes. The oil will rapidly absorb moisture from the air, and the contact time must be kept to a minimum.

A special or very sensitive electronic leak detector will be needed to locate refrigerant leaks. Many are on the market that will sense R-134a.

Recovery and vacuum equipment should use polyolester oil to minimize cross-contamination.

### A HFC type drier must be used.

As with any other refrigerant, do not place pressurized air or oxygen into the refrigeration system.

Evacuation to 200 microns is recommended.

Temperature in °F.	PSIG of R-134a
-10	2.0
-6	3.7
-4	4.6
-2	5.5
0	6.5
1	7.0
2	7.5
3	8.0
4	8.6
5	9.1
10	12.0
12	13.2
14	14.4
16	15.7
18	17.1
20	18.4
25	22.1
30	26.1
31	26.9
32	27.8
33	28.6
34	29.5
35	30.4
40	35.0
45	40.0
50	45.4
75	78.7
90	104.3
110	146.4
120	171.1
130	198.7
150	262.8

## Gear Reducer Removal

---

1. Disconnect electrical power.

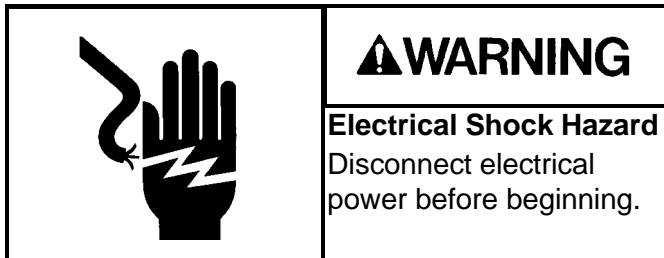

2. Shut off the water supply.
  3. Remove the top, front and side panel.
  4. Remove the control box cover.
  5. Remove the centrifugal switch cover on the top of the auger drive motor.
  6. Disconnect the electrical wires from the centrifugal switch.
  7. Drain the evaporator and reservoir.
  8. Disconnect the water inlet tube from the evaporator.
  9. Remove the three screws holding the evaporator to the adapter stand.
  10. Lift the evaporator up high enough for the auger to clear the adapter stand.
  11. Remove the mounting bolts holding the gear reducer to the cabinet frame.
  12. Trace auger drive motor wires back to the control box.
  13. Disconnect the drive motor wires from the relay on the circuit board.
  14. Pull the wires back to the auger drive motor.
  15. Pull the gear reducer out the side of the cabinet to remove it from the machine.
- Note: If there is evidence of water near the output shaft of the gear reducer, it would be a wise precaution to pull the auger from the evaporator and check the bearings.
16. Rebuild or replace the gear reducer.

# AFE325

## Gear Reducer Rebuild

---

1. After the gear reducer has been removed, the internal components may be inspected and/or replaced. Remove all bolts holding the two case halves together.
2. Tap against the roll pins at each end of the gear cases to split them.
3. Pry the case halves apart.
4. Check the internal condition of the gear reducer. If rusty or water is present, replace the complete assembly. The oil should be black and the proper oil level is 1/8" from the top of the biggest gear (with all gears installed). Check the input seal.

The gears may be replaced individually.

### Auger Drive Motor

The windings or top bearing & cover may be replaced without removing the evaporator or gear reducer from the machine.

1. Disconnect electrical power.

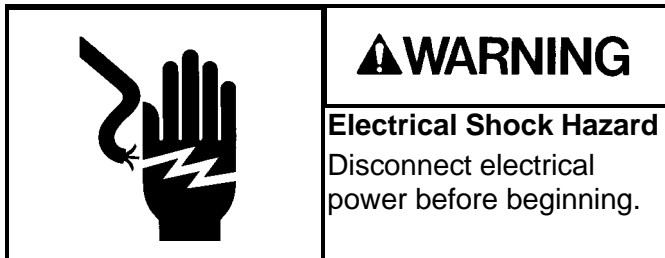

2. Shut off water supply.
3. Remove top panel.
4. Remove right side panel.
5. Drain the reservoir and evaporator.
6. Disconnect the reservoir outlet tube from the bottom of the reservoir.
7. Remove screws holding reservoir mounting bracket to the cabinet.
8. Lift the reservoir up & away from the top of the auger drive motor.
9. Remove the 4 bolts holding the auger motor cover to the gear reducer case.
10. Lift the plastic switch housing off the auger drive motor.
11. Hold the centrifugal switch and remove the screw holding it to the rotor of the motor.
12. Lift the centrifugal switch up and off the motor.
13. Lift the motor cover up and off the motor.
14. Pull the fan up and off the rotor.

If the windings are to be replaced, remove the left side panel and control box cover.

1. Locate the auger drive motor wires plugged into a relay on the circuit board.
2. Disconnect the auger motor's wires and pull them back to the auger drive motor.
3. Lift the auger motor windings off the gear reducer.

If the rotor needs to be removed:

1. Run a screw into the top of the rotor.
2. Grasp the screw with a grip pliers.
3. Pull and/or tap on the pliers to pull the rotor & bearing out of the gear reducer.
4. Inspect the bearing and input seal. Replace them if worn.

Note: When the rotor is re-installed, be certain that the bearing is fully seated in the gear case.

Gear Reducer

