

A

Stereo Component System

SEN-280

Operating Instructions

Before operating the unit, please read this manual thoroughly.
This manual should be retained for future reference.

Owner's Record

The model and serial numbers are located at the rear of each model. Record the serial numbers in the spaces provided below. Refer to these numbers whenever you call upon your Sony dealer regarding these products.

Model No. PS-LX285	Serial No. _____
Model No. TA-AX285	Serial No. _____
Model No. ST-JX285	Serial No. _____
Model No. TC-W285	Serial No. _____

WARNING

To prevent fire or shock hazard, do not expose the unit to rain or moisture.

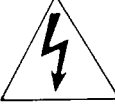

CAUTION
RISK OF ELECTRIC SHOCK
DO NOT OPEN



CAUTION TO REDUCE THE RISK OF ELECTRIC SHOCK,
DO NOT REMOVE COVER (OR BACK).
NO USER-SERVICEABLE PARTS INSIDE.
REFER SERVICING TO QUALIFIED SERVICE PERSONNEL.

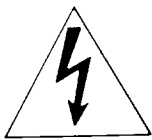

This symbol is intended to alert the user to the presence of uninsulated "dangerous voltage" within the product's enclosure that may be of sufficient magnitude to constitute a risk of electric shock to persons.



This symbol is intended to alert the user to the presence of important operating and maintenance (servicing) instructions in the literature accompanying the appliance.

Note to CATV system installer

This reminder is provided to call the CATV system installer's attention to Article 820-22 of the NEC that provides guidelines for proper grounding and, in particular, specifies that the cable ground shall be connected to the grounding system of the building, as close to the point of cable entry as practical.

Table of Contents

Getting started

Precautions	3
Turntable assembly (Canadian model only)	3
Connections	4

Using your stereo

Audio adjustment	6
Receiving radio programs	6
Automatic tuning	6
Manual tuning	6
Memory preset	8
Receiving a memorized station	8
Scanning the memorized station	8
Tape playback (on either deck A or B)	10
Tape recording (deck B)	10
Tape dubbing	12
Playing record	12
Remote commander (Supplied)	14

Maintaining your stereo

Maintenance	14
-------------------	----

Getting into the details

Specifications	15
----------------------	----

Troubleshooting

Troubleshooting guide	back cover
-----------------------------	------------

Precautions

On safety

- Operate the stereo system only on 120 V AC, 60 Hz.
- Unplug the stereo system from the wall outlet if it is not to be used for an extended period of time. To disconnect the cord, pull it out by grasping the plug. Never pull the plug out by the cord.
- Do not place anything on top of the amplifier. The ventilation holes must be unobstructed for the proper operation of the unit and to prolong the life of its components.
- Should any liquid or solid object fall into the unit, unplug the stereo system, and have the unit checked by qualified personnel before operating it any further. For repairs, take in all the components together, even if only one needs repairing.

On installation

- Avoid installing or leaving the stereo system in a location:
 - near heat sources such as radiators, airducts or heaters subject to direct sunlight
 - exposed to rain or moisture
 - where it is liable to come into contact with dust or dirt
 - that is unventilated, such as a bookcase

If you have any question or problem concerning your stereo system that is not covered in this manual, please consult your nearest Sony dealer.

For the customers in the U.S.A.

For detailed precautions, see the leaflet "IMPORTANT SAFEGUARDS".

For the customers in Canada

CAUTION:

TO PREVENT ELECTRIC SHOCK, DO NOT USE THIS POLARIZED AC PLUG WITH AN EXTENSION CORD, RECEPTACLE OR OTHER OUTLET UNLESS THE BLADES CAN BE FULLY INSERTED TO PREVENT BLADE EXPOSURE.

To change the AM tuning interval

The AM tuning interval is preset at the factory to 10 kHz to match the frequency allocation system of your country.

To change the interval to 9 kHz, proceed as follows.

- 1 Depress the POWER switch to turn on the system.
- 2 Press the TUNER button.
- 3 Press the BAND FM/AM selector to select AM.
- 4 Press the POWER switch to turn off the system.
- 5 While pressing the "+" TUNING button, press the POWER switch to turn it on.

To reset the interval to 10 kHz, follow the same procedure.

Note

When the interval is changed, all stations memorized to the 10-key station preset selector will be erased.

After changing the interval, be sure to memorize the stations again.

Turntable Assembly (Canadian model only)

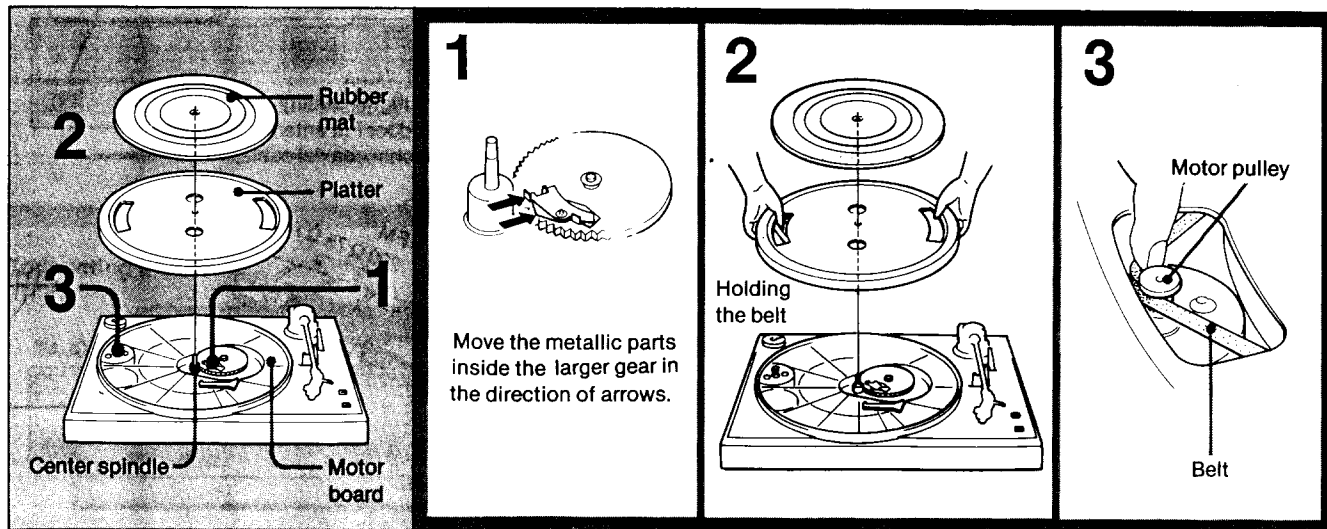

Connections

- The power cord should be connected last of all, first making sure that the SYSTEM POWER switch is turned off.
- The cable connectors should be fully inserted into the connectors. A loose connection may cause hum and noise.
- Keep the speaker cords, connecting cords and power cord away from the AM loop antenna and the tuner's antenna lead-in to avoid possible noise pickup.

Conventional audio cord connection

Cord plugs and jacks are color coded. The red plugs and jacks are for the right channel (R) and white ones for the left channel (L).

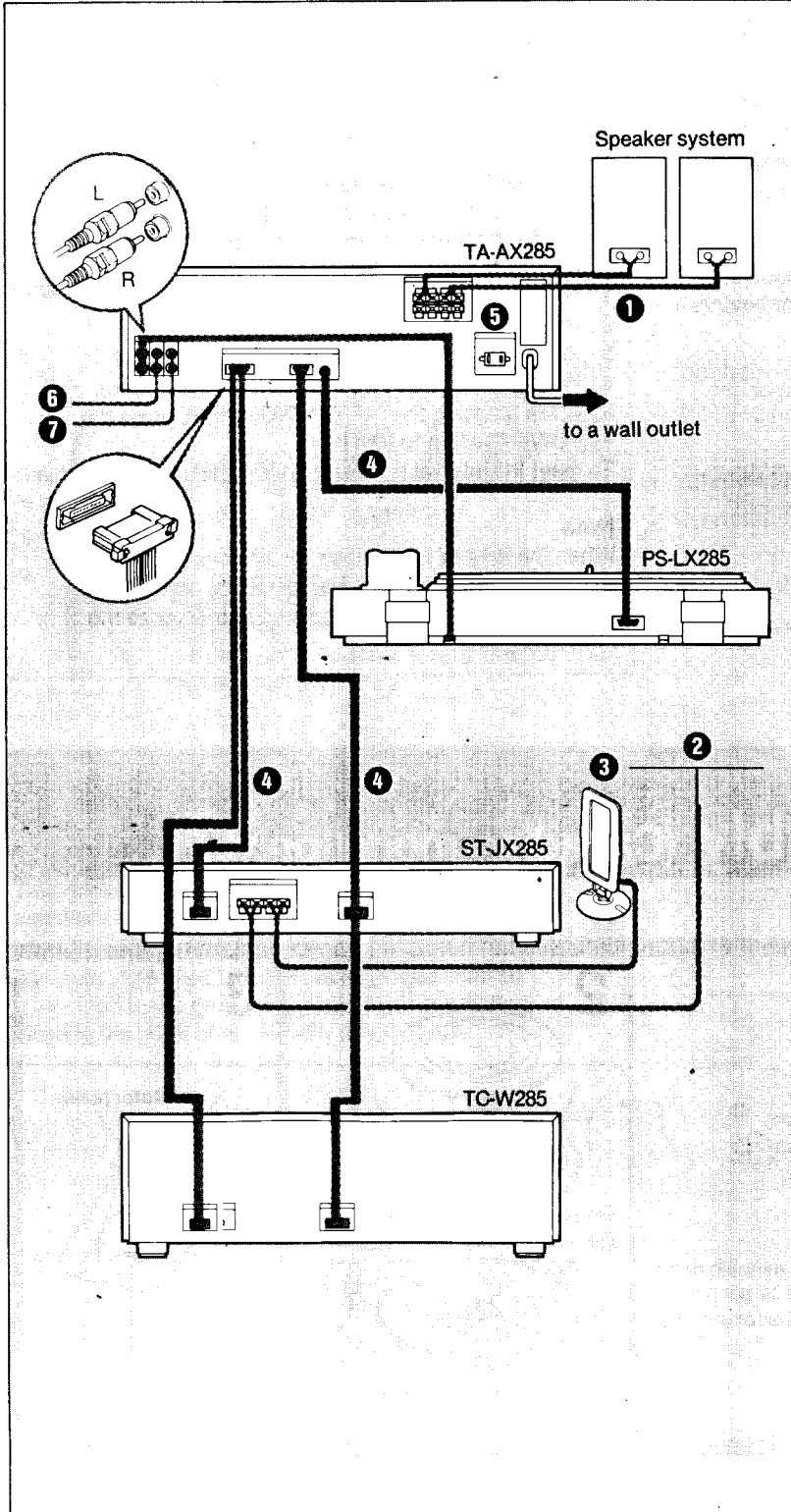

1 Speaker cords

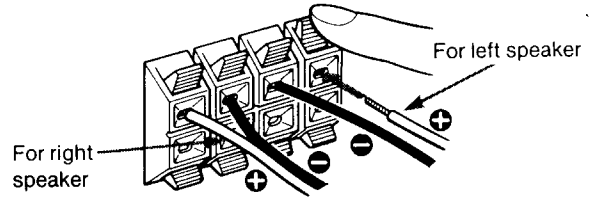

The TA-AX285 has connectors for two pairs of speaker systems—system A and system B—which can be selected individually or simultaneously by means of the front panel SPEAKERS select buttons. No sound will be heard if only one of the speaker system is connected and the SPEAKERS select buttons A and B are depressed.

2 FM antenna

Supplied FM wire antenna
For normal reception.

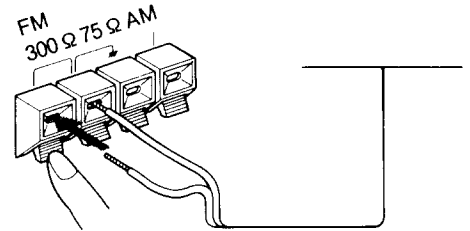

For higher quality reception.
Outdoor FM antenna
(75-ohm coaxial cable)

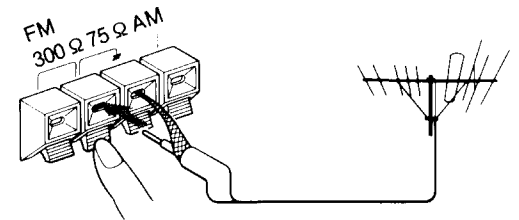

3 AM loop antenna (supplied)

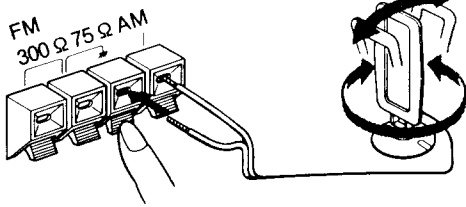

For better AM reception.
Extend a 6 to 15-meter insulated wire out of doors

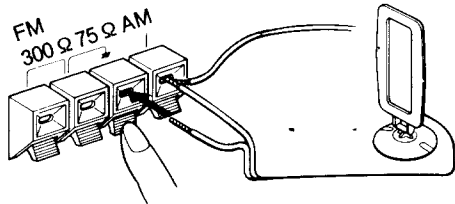

4 Supplied flat cord connection

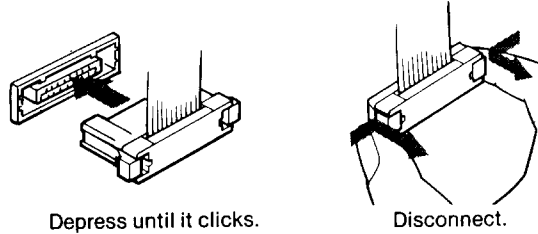

Depress until it clicks.

Disconnect.

5 AC OUTLET

These are used to power other audio components whose power consumption is less than the wattage indicated on the AC outlet.

SWITCHED: This outlet is controlled by the POWER switch.

CAUTION: Do not connect any electrical home appliances such as an electric iron, fan, TV or other high wattage equipment to these AC outlets.

6 Connecting a CD player



7 Connecting a VCR



Audio Adjustment

Volume Adjustment

Turn VOLUME clockwise to increase the sound level.
To decrease it, turn the control counterclockwise.

To decrease the sound level temporarily

Press MUTING. The sound cannot be heard.

To resume the original level, press the button again.

Sound Quality Adjustment

Adjust the graphic equalizer controls according to:

- Personal preference.
- The room acoustics: For instance, playback in a room with padded walls or furniture will probably sound better with the high frequencies boosted.
- Program quality. If reception contains hiss, cutting the high frequencies will improve reproduction.

Receiving Radio Programs

Before reception, be sure to connect the supplied AM and FM antenna.

Automatic Tuning

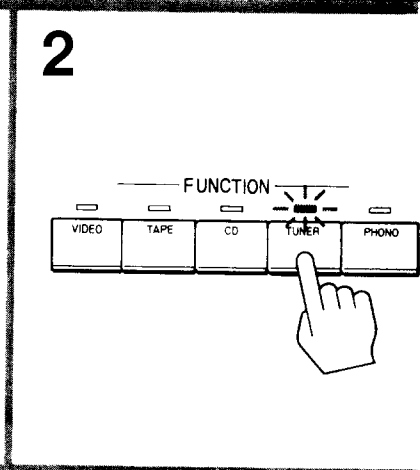
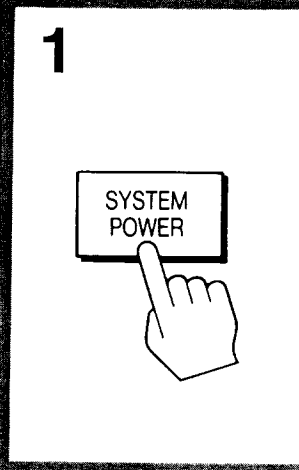
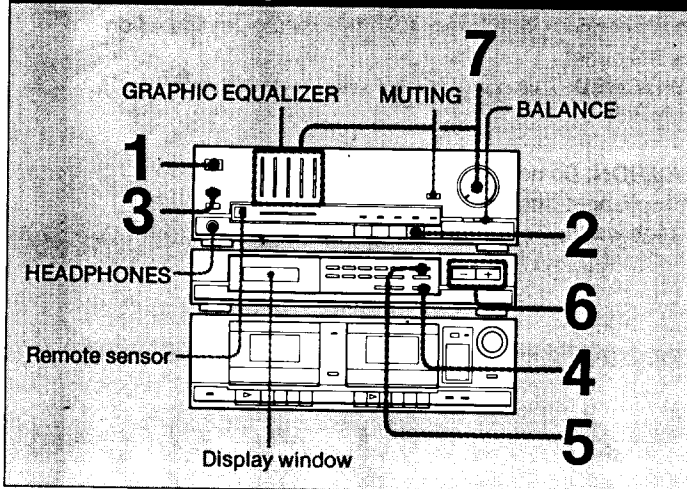

Manual Tuning

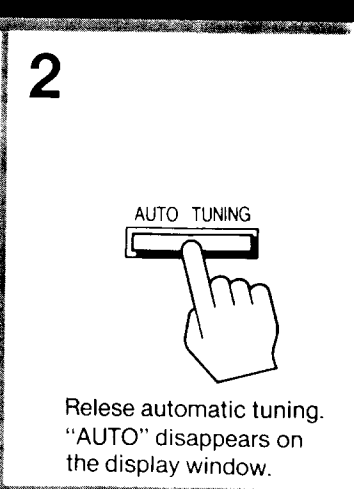
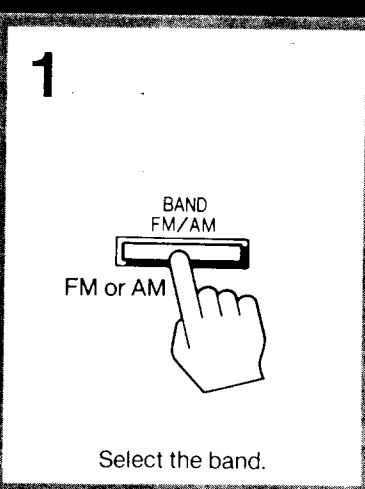
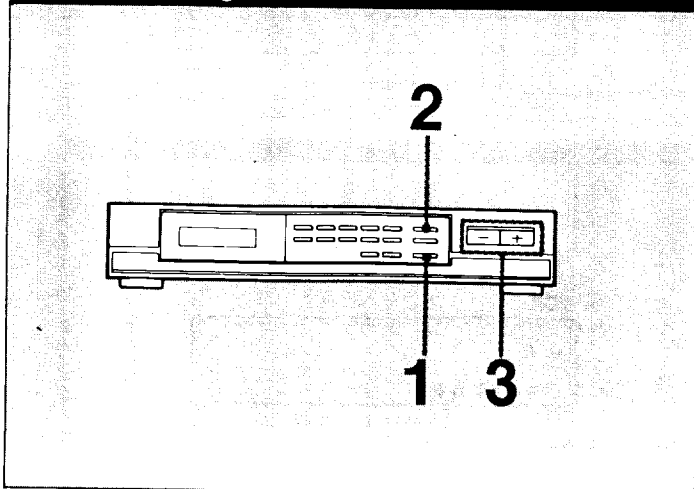

Graphic Equalizer Controls

To equalize the listening to sound, slide each control upwards to increase the level of the frequency band, and downwards to decrease the level.

100 Hz: Use to boost or cut the bass.

400 Hz: Use to adjust the middle frequency range.

1 kHz: Use to provide more presence of vocals.

4 kHz: Use to adjust the brightness of sound.

12 kHz: This control effects general treble. Slide downwards to reduce high frequency noise, such as tape hiss.

To listen to the sound with the original tone quality, set all the controls at their center positions.

Balance Adjustment

When speaker position is not symmetrical, adjust the strength of left and right speaker outputs with the left and right graphic equalizer controls.

Selecting the speaker system

To drive speaker system A: depress button A.

To drive speaker system B: depress button B.

To drive both speakers: depress buttons A and B.

Note

When both A and B buttons are depressed, two pairs of speaker system should be connected. Otherwise, no sound can be heard.

For headphone listening only: keep both buttons released.

3

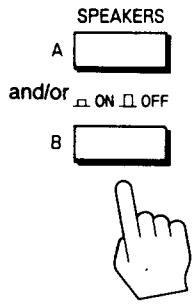

4

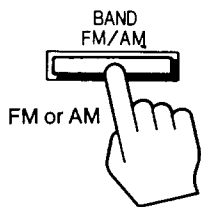

Select the band.

5

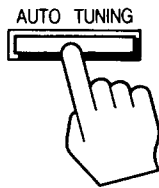

"AUTO" appears on the display window.

6

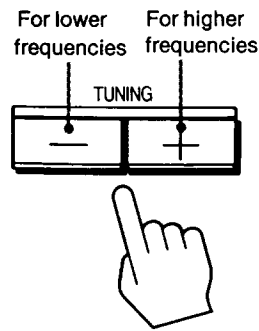

Select the station.

7

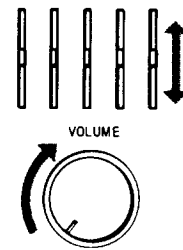

3

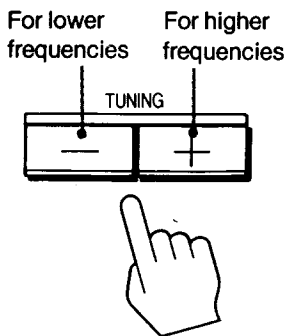

Select the station.

In the display window

- The TUNED Indicator appears in the display window when a station is tuned in.
- The STEREO Indicator appears when an FM stereo program of sufficient signal strength is received.

Receiving Radio Programs

You can memorize up to 25 FM and AM stations in any sequence.

Memory Preset

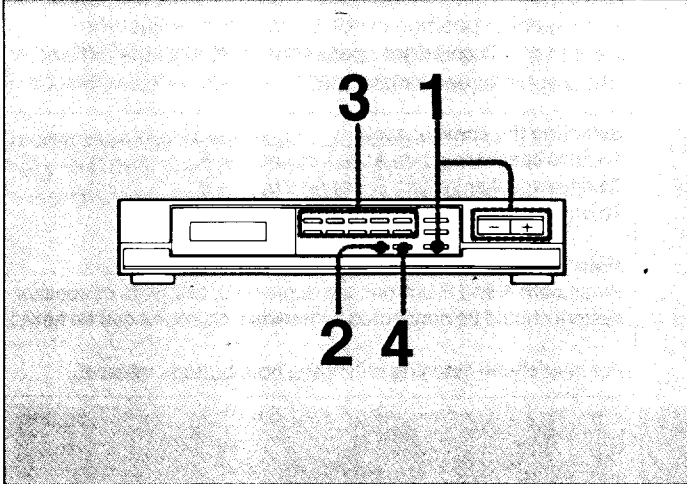

1

BAND FM/AM

For a lower frequencies. For a higher frequencies.

TUNING

Tune in the desired station.

2

MEMORY

Receiving a Memorized Station

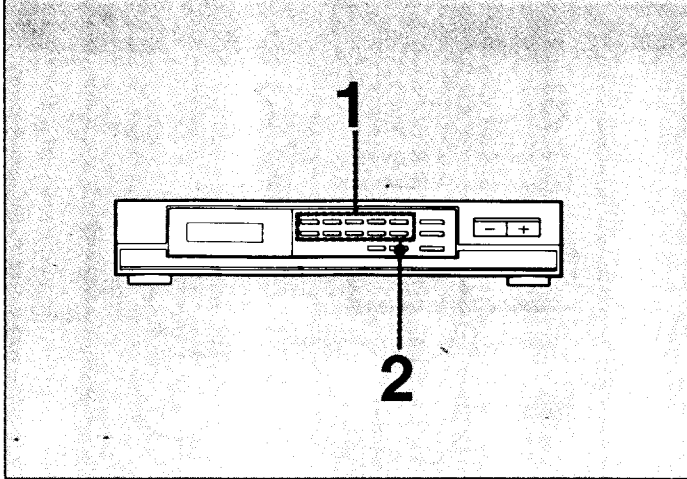

1

1 2 3 4 5
6 7 8 9 0

Enter the desired number

2

ENTER

Scanning the Memorized Station

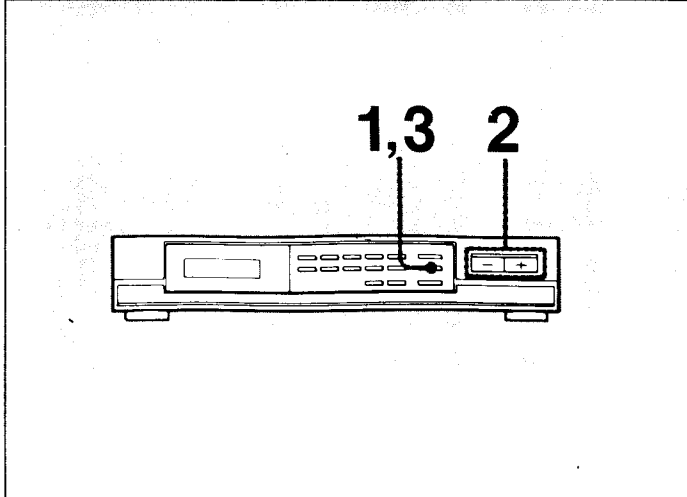

1

MEMORY SCAN

2

For lower frequencies. For higher frequencies.

TUNING

3

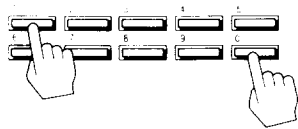

While the MEMORY indicator is lit, select a station number (1 or 25).

4

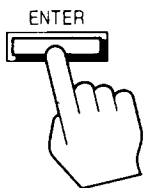

The tuned station has been memorized.

Important

- The "MEMORY" indication will go off after a few seconds. If the "MEMORY" indication has gone off, press MEMORY again.
- Storing a new station on a preset station number erases the previously memorized station.

To select a station number of two digits

Press the first digit followed by the second one.

For example: To memorize a station to "10", press "1" then "0".

3

MEMORY SCAN

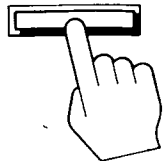

Stop scanning.

Which stations are skipped during memory scanning?

The memory scanning function skips numbers which are not preset, and also skips stations with a weak signal strength.

Tape Playback (on either deck A or B)

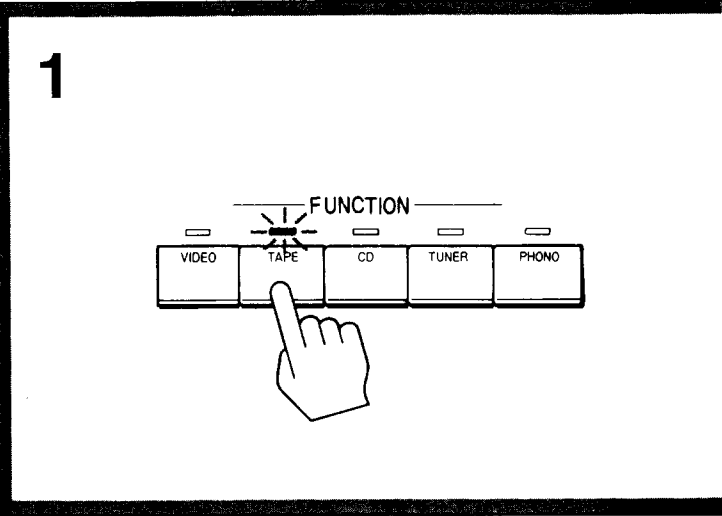
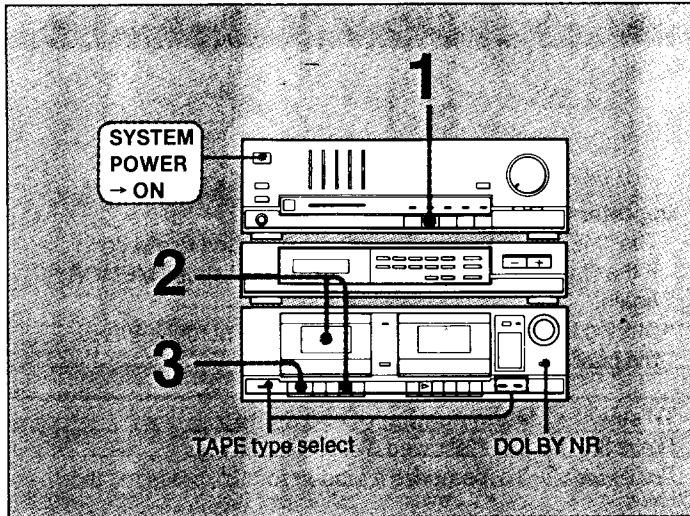

Tape Recording (deck B)

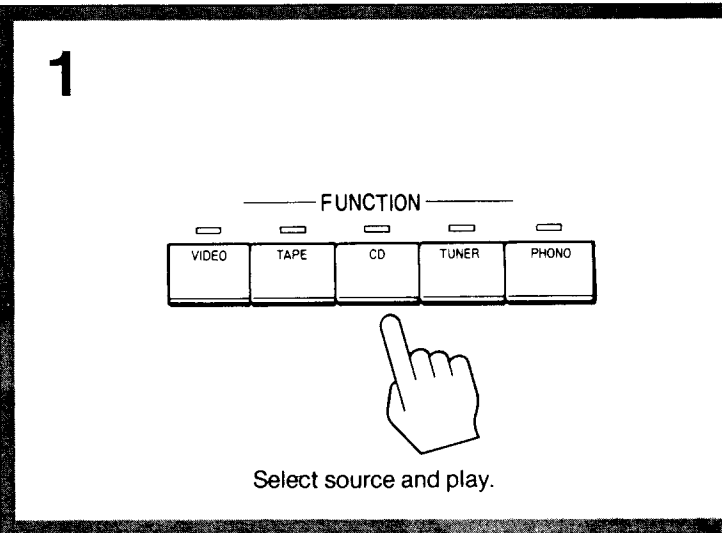
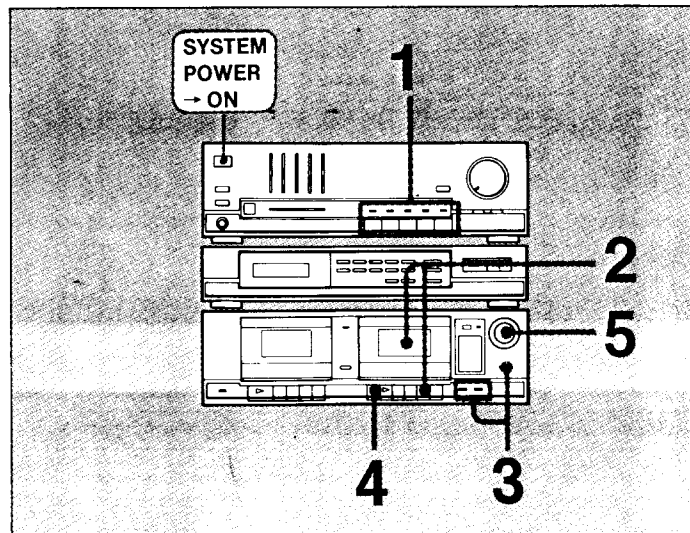

To stop recording
Press ■ ▲.

To start recording more precisely

- 1 Press ■.
- 2 Press ●.
- 3 Adjust recording level.
- 4 Press ■ again at the desired point.

Dolby setting

The DOLBY NR switch operates on both decks A and B.

	DOLBY NR switch
Cassette recorded with Dolby NR	ON (■)
Non-Dolby cassette	OFF (□)

Tape type selection

When playing back select the tape type with the TAPE (DECK-A, DECK-B) selectors referring to the tape list below.

Tape Type	Tapes (C-46 – C-90)
Type I (NORMAL)	SONY: HF, HF-S, HF-ES Other TYPE I equivalent tapes (For 120 μs and NORMAL BIAS)
TYPE II (CrO ₂)	SONY: UX, UX-S, UX-ES, UX-PRO Other TYPE II equivalent tapes (for 70 μs and HIGH BIAS)
TYPE IV (METAL)	SONY: METAL-ES Other TYPE IV equivalent tapes (For 70 μs and METAL BIAS)

2

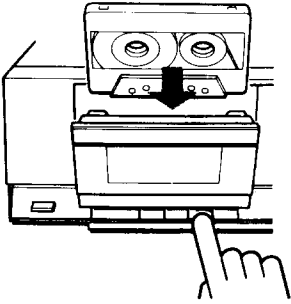

Exposed tape facing down.

3

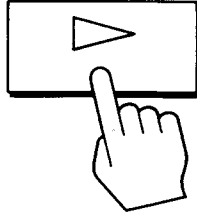

To stop playback
Press ■ ▲.

When both decks A and B are in the playback mode
Only playback from deck A will be audible.

Note

Be sure to release the ▷ or ● button with the ■ ▲ button before turning off the power.
For tape type selector and Dolby NR switch, refer to lower part of page 10.

2

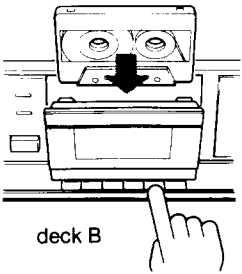

deck B

3

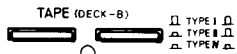

Select tape type selector and Dolby NR.

4

REC INDICATOR

Lights up.

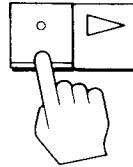

5

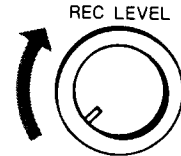

Adjust recording level.

Recording Level Adjustment

Adjust the recording level according to the tape type by observing the PEAK LEVEL METERS.

Recommended maximum peak level meter reading

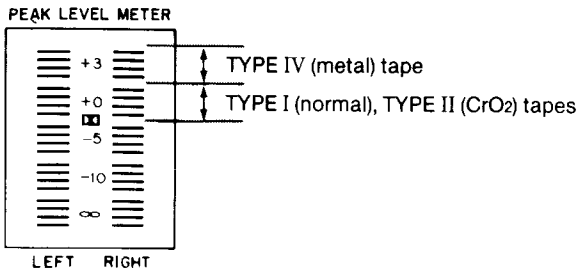

If the recording level setting is too high, the recording will be distorted, and if it is too low, the tape will produce a hissing sound.

To prevent accidental erasure
To protect side A recording

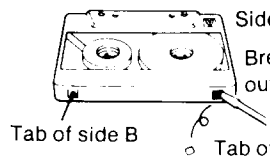

To reuse a cassette

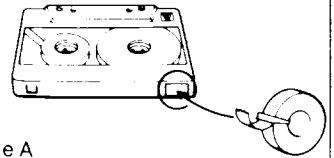

Tape Dubbing

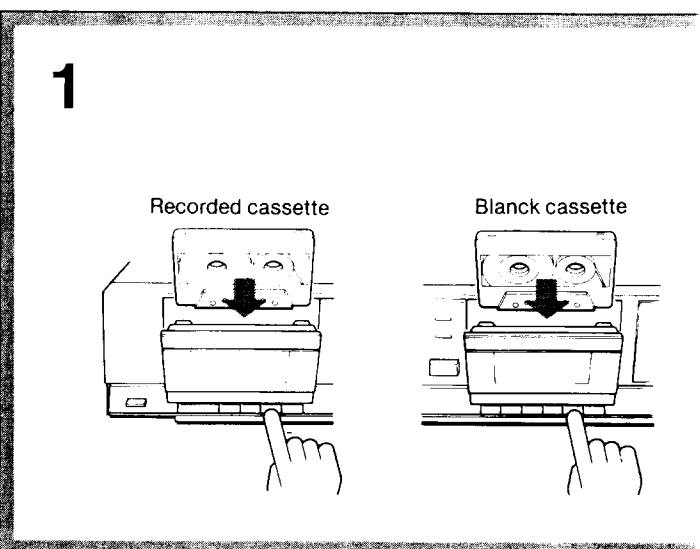
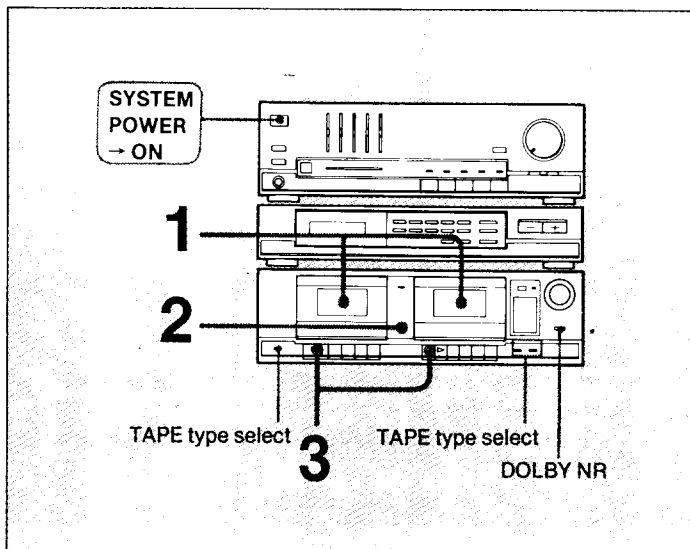

Playing Record (The dust cover is not supplied the U.S.A.)

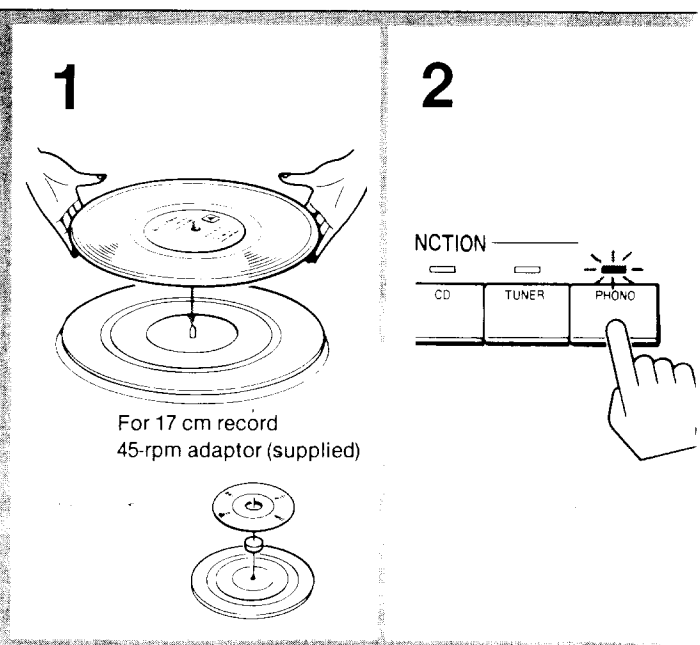
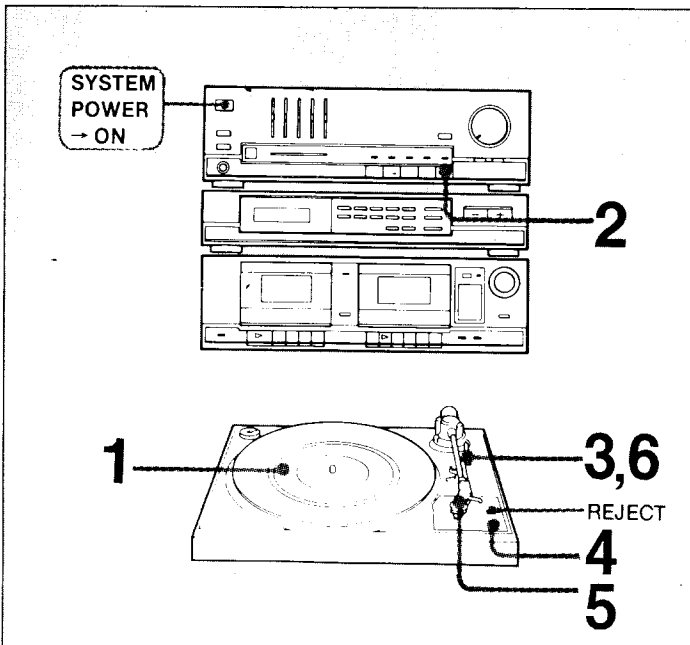

When the record has finished playing

When the tonearm reaches the end of the record, it will automatically return to the arm rest.

To lift up the stylus during play

Set the cueing lever to ▼.

To stop during play

Press REJECT.

2

DUBBING SPEED
HIGH □ NORMAL

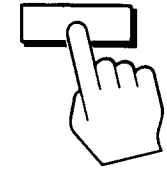

Select tape type selector and Dolby NR.
(Refer to lower part of page 10.)
Select dubbing speed.
To dub a whole tape: HIGH □
To edit the tape: NORMAL □

3

Deck A

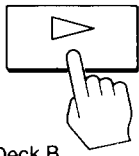

Deck B

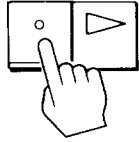

Dubbing will start.

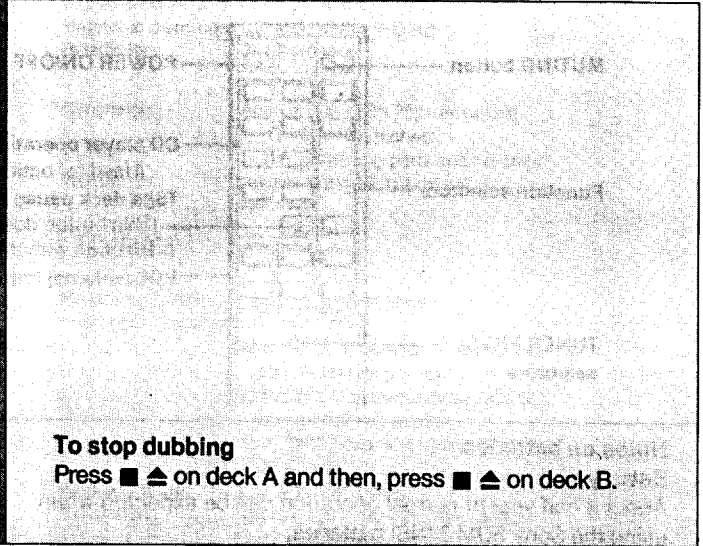

To stop dubbing
Press ■ ▲ on deck A and then, press ■ ▲ on deck B.

model.)

3

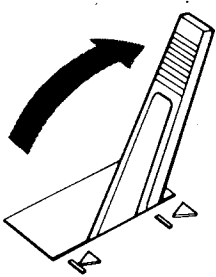

4

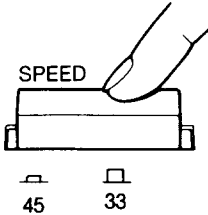

Select speed.

5

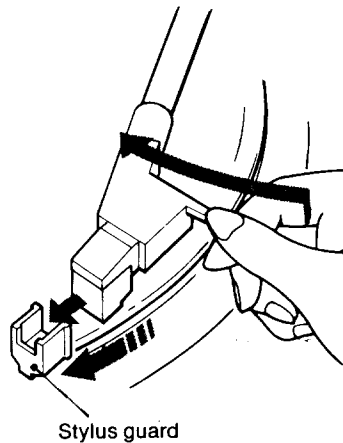

Stylus guard

6

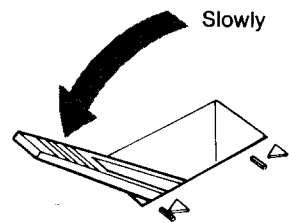

Slowly

Note

- If the tonearm does not return to the arm rest, during initial operation, press the REJECT button. After this the tonearm automatically returns to the arm rest.
- If you move the tonearm close to the center while the turntable is rotating, the tonearm may return to the arm rest. Do not resist this movement, as this may damage the automatic return mechanism.

Remote Commander (Supplied)

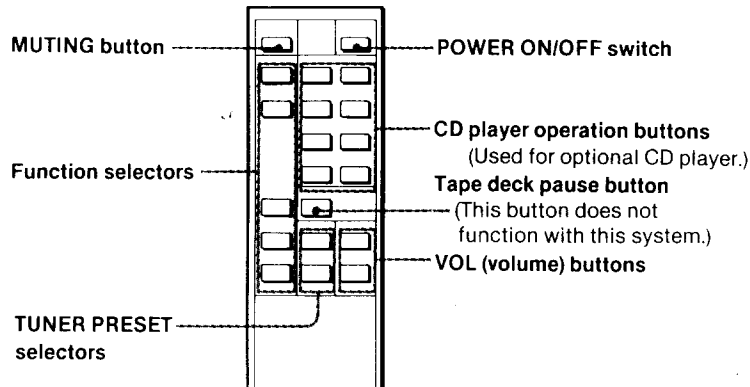

Installing Batteries

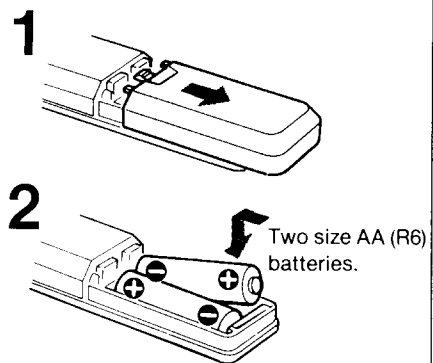

Notes on batteries

Battery life

About a half year of normal operation can be expected when using the Sony SUM-3 (NS) batteries.

When the batteries are exhausted, the remote commander cannot operate the unit. If this happens, replace both batteries with new ones.

To avoid battery leakage

When the commander is not to be used for a long time, remove the batteries to avoid damage caused by battery leakage and corrosion.

Note With some Sony CD players, the SHUFFLE and PGM modes of this commander cannot be released. To do so, use the CONTINUE button in the CD player.

Maintenance

Cleaning the Heads and Tape Path (both decks)

Clean after every 10 hours of operation and before recording for optimum record/playback quality.

- 1 Press of the both decks A and B.
- 2 Slightly moisten the tip of a cotton swab with cleaning fluid or alcohol.
- 3 Wipe heads, pinch roller and capstan.

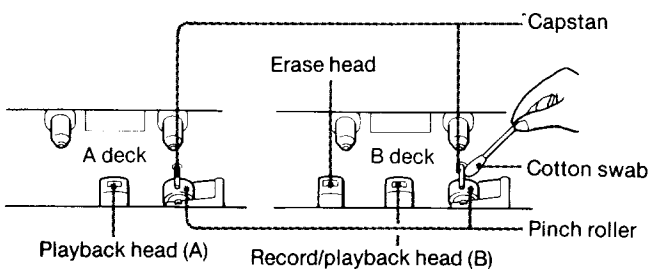

Do not insert cassette until cleaned areas are completely dry.

Demagnetizing the Heads (both decks)

After 20 to 30 hours of use, it is necessary to remove residual magnetism built up on the head.

Turn off the power and demagnetize heads with any commercially available demagnetizer.

Cleaning the Cabinet

Replace the stylus after approximately 400 hours of use. An ND-155G replacement stylus is available at your Sony dealer. Handle this delicate stylus with care.

- 1 Turn off POWER of the amplifier.
- 2 Secure the tonearm to the arm rest.
- 3 Detach the stylus assembly by grasping it with your fingers.
- 4 Insert the new stylus.

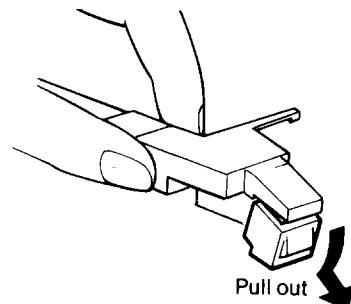

Replacing the Stylus

Clean the cabinet, panel and controls with a soft cloth lightly moistened with a mild detergent solution. Do not use any type of abrasive pad, scouring powder or solvent, such as alcohol or benzene.

Specifications

AUDIO POWER SPECIFICATIONS POWER OUTPUT AND TOTAL HARMONIC DISTORTION:

With 8 ohm loads, both channels driven, from 20—20,000 Hz; rated 100 watts per channel minimum RMS power, with no more than 0.08% total harmonic distortion from 250 milliwatts to rated output.

Other Specifications

TA-AX285

Inputs

	Sensitivity	Impedance
PHONO	2.0 mV	50 kilohms
TUNER/CD/ VIDEO/TAPE	150 mV	50 kilohms

Outputs REC OUT: Voltage 150 mV, Impedance 1 kohms
SPEAKER: Accepts speaker of 8 to 16 ohms
HEADPHONES: Accepts headphones with low and high impedance

Frequency response PHONO: RIAA curve ± 0.5 dB
TUNER/CD/VIDEO/TAPE: 7 Hz - 70 kHz ± 3 dB

GRAPHIC EQUALIZER controls

Boost/cut range:
 ± 8 dB (100 Hz, 400 Hz, 1 kHz, 4 kHz)
 ± 6 dB (12 kHz)

Dimensions Approx. 430 x 130 x 355 mm
(17 x 5¹/₈ x 14 inches)

Weight Approx. 8.2 kg (18 lb 2 oz) net

ST-JX285

System FM stereo, FM/AM superheterodyne tuner
Quartz-locked digital synthesizer system

FM tuner section

Tuning range 87.5 - 108 MHz
Antenna terminals 75 ohms unbalanced
300 ohms balanced

Intermediate frequency

10.7 MHz

Sensitivity at 50 dB quieting
22.1 dBf, 7 μ V (mono)
42.1 dBf, 70 μ V (stereo)

Usable sensitivity 19.5 dBf, 5 μ V (IHF)

Signal-to-noise ratio (at 75 kHz deviation)
80 dB (mono)
75 dB (stereo)

Harmonic distortion 0.3% (mono)
0.5% (stereo)
at 1 kHz

Separation 40 dB at 1 kHz

Selectivity 55 dB at 400 kHz

AM tuner section

Tuning range 530 - 1,610 kHz
Antenna AM loop antenna,
External antenna terminal

Intermediate frequency

450 kHz

Usable sensitivity AM loop antenna:
500 μ V/m (1,000 kHz)

Signal-to-noise ratio 54 dB (50 mV/m)
Harmonic distortion 0.3% (50 mV/m, 400 Hz)
Selectivity 38 dB (10 kHz)

Dimensions Approx. 430 x 80 x 250 mm (w/h/d)
(17 x 3¹/₈ x 9⁷/₈ inches)
incl. projecting parts and controls

Weight Approx. 1.9 kg (4 lb 4 oz) net

TC-W285

Recording system 4-track 2-channel stereo
Frequency response DOLBY NR OFF
With TYPE IV cassette (Sony METAL-ES)
30 - 15,000 Hz (± 3 dB)
With TYPE II cassette (Sony UCX-S)
30 - 14,000 Hz (± 3 dB)
With TYPE I cassette (Sony HF-S)
30 - 13,000 Hz (± 3 dB)

Wow and flutter 0.12% WRMS (NAB)

Dimensions Approx. 430 x 130 x 250 mm (w/h/d)
(17 x 5¹/₈ x 9⁷/₈ inches)
incl. projecting parts and controls

Weight Approx. 2.85 kg (6 lb 6 oz) net

PS-LX285

Turntable

Platter 30 cm (12 in.)
Motor DC servo motor
Drive system Belt-drive
Speed 33¹/₃ rpm, 45 rpm
Automatic system Return, reject
Tonearm type Statically balanced

Cartridge

Type Moving magnet type
Stylus Sony ND-155G (0.6 mil diamond)
Dimensions U.S.A. model:
Approx. 430 x 95 x 350 mm (w/h/d)
(17 x 3⁷/₈ x 13⁷/₈ inches)
Canadian model:
Approx. 430 x 105 x 350 mm (w/h/d)
(17 x 4¹/₈ x 13⁷/₈ inches)

Weight U.S.A. model:
Approx. 2.5 kg (5 lb 9 oz) net
Canadian model:
Approx. 3.3 kg (7 lb 5 oz) net

General

Power requirements 120 V ac, 60 Hz
Power consumption U.S.A. model 175 W
Canadian model 385 VA

AC outlet 1 switched, 100 W max.

Accessories supplied

Flat cord with 7-pin connectors (1)
Flat cord with 11-pin connectors (1)
AM loop antenna (1)
FM ribbon antenna (1)
45-rpm adaptor (1)
Dust cover (1) (Canadian model only)
RM-S380 Remote commander (1)
Sony SUM-3 (NS) batteries (2)

Design and specifications subject to change without notice.

Troubleshooting Guide

The following checks will assist in the correction of most problems which you may encounter with you set. Should any problem persist after you have made these checks, consult your nearest Sony service facility.

Before going through the check list below, first pay attention to the following fundamental points.

- The power cord must be firmly connected.
- The speaker connection must be firmly made.
- The flat cord and other connecting cords must be firmly connected.

Radio Program Reception

The STEREO indicator flickers.	<ul style="list-style-type: none"> • Adjust the antenna.
Severe hum or noise	<ul style="list-style-type: none"> • The signal strength is too weak. Connect the external antenna. • Adjust the antenna. • Connect the ground wire.

Cassette Deck Operation

The ● button does not activate.	<ul style="list-style-type: none"> • No cassette in the cassette holder. • The tab is removed from the cassette.
The ● button or ► button cannot be activated.	<ul style="list-style-type: none"> • The tape is wound completely.
Tape does not run even when the ► button is depressed.	<ul style="list-style-type: none"> • The ■■ button is depressed. • The cassette holder is not properly closed.
Noises increase while recording and playback. There is a decrease in sound level.	<ul style="list-style-type: none"> • Dirty heads. • Magnetic built-up on the heads.
Excessive wow or flutter, or sound drop-out.	<ul style="list-style-type: none"> • Contamination of the capstan or pinch roller.
Insufficient erasure	<ul style="list-style-type: none"> • Dirty erase head.
Unbalanced tone in higher frequencies	<ul style="list-style-type: none"> • The DOLBY NR switch is set incorrectly. During playback, set the switch to the same position as that used when the tape was recorded. • Set the TAPE type selectors to the appropriate position.

Turntable Operation

Impaired tone quality	<ul style="list-style-type: none"> • Dusty stylus. • Worn stylus.
No audio from one channel	<ul style="list-style-type: none"> • Loose connection of phono cord.
Groove skipping/tonearm skating/tonearm not advancing	<ul style="list-style-type: none"> • Turntable is not level. • Defective record.
Loud rumble or low-frequency howl	<ul style="list-style-type: none"> • The turntable is subjected to external vibration. • The turntable is placed too near the speaker.

General

No audio	<ul style="list-style-type: none"> • Turn the VOLUME control clockwise. • Check the SPEAKERS select buttons setting. • Check the MUTING switch setting.
No audio from one channel or unbalanced left and right volume	<ul style="list-style-type: none"> • Adjust the BALANCE control. • Check the speaker connections of the inoperative channel.
Reversed left and right sound	<ul style="list-style-type: none"> • Check the speaker cord connection and speaker location.
Lack of bass sound or apparently imprecise physical location or musical instruments	<ul style="list-style-type: none"> • Check the ⊕ ⊖ speaker cord connection for proper phasing.