

SONY®

DIGITAL HD VIDEOCASSETTE
RECORDER

HVR-1500
HVR-1500A

DIGITAL VIDEOCASSETTE
RECORDER

DSR-70/70P
DSR-70A/70AP
DSR-80/80P
DSR-85/85P
DSR-1500/1500P
DSR-1500A/1500AP
DSR-1800/1800P
DSR-1800A/1800AP
DSR-2000/2000P
DSR-2000A/2000AP

DIGITAL VIDEOCASSETTE PLAYER

DSR-60/60P
DSR-1600/1600P
DSR-1600A/1600AP

VIDEO DISK RECORDER

DSR-DR1000/DR1000P
DSR-DR1000A/DR1000AP

DV CAM™

PROTOCOL MANUAL
1st Edition (Revised 8)

COPYRIGHT NOTICE

Copyright © by Sony Corporation.

All rights reserved. The copyright on all matters described in this manual belongs to Sony Corporation, and the contents are intended for use by purchasers of subject equipment.

Furthermore, Sony Corporation reserves the right to revise this publication and to make changes from time to time in the content hereof without obligation of Sony Corporation to notify any person or organization of such revision or changes.

Table of Contents

1. Summary	1
2. Interface System Overview	1
3. Command Block Format (CMD Block)	2
3-1. VTP Command	2
3-2. DSR-DR1000/A DISK Command	3
4. Connector Pin Assignment	7
5. Communication Protocol	8
6. Command	9
6-1. Command Table (for Cassette Recorder/Player)	9
6-2. Command Table (for Disk Recorder)	15
6-3. Command Table (for DSR-DR1000/A Disk Command)	20
7. Protocol Command	21
7-1. VTR Command	21
7-2. DSR-DR1000/A Disk Command (Ver 1.10 or later)	54
7-3. Items supported from DSR-DR1000/A disk command V2.00	72
7-4. Special Commands for HVR Series	75
7-4-1. Command Table	75
7-4-2. Detailed Description of Commands	75
8. Time Data Format	77
9. Appendix-1	77
10. Appendix-2	78
11. Appendix-3	79

1. Summary

The DSR series VTR, Remote Control Connector Panel, incorporate with a 9-pin D-Subminiature connectors for REMOTE.

This connector is utilized for a serial control system.

The definition of CONTROLLER and DEVICE is shown in the follows,

“CONTROLLER” means the unit which controls VTR.

“DEVICE” means the unit (VTR) which is controlled.

Example 1)

When the DSR series VTR is connected by REMOTE (9-pin) connector, the VTR as the recorder means CONTROLLER and the VTR as the player means DEVICE.

Example 2)

When the editing controller is connected with one or plural DSR series VTR (s), this editing controller is CONTROLLER and all VTRs are DEVICES.

2. Interface System Overview

- Conforming to EIA RS-422A.
- Full duplex communications channel is utilized.
- Data is transmitted asynchronously, bit serial, word serial with data exchange between devices.
- Standard transmission rate on the interface bus is 38.4 kilobits per second (kb/s).
- The data word utilized by the interface system is as follows :

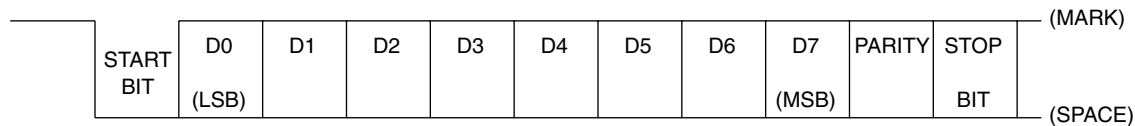

- 1 START BIT + 8 DATA BITS + 1 PARITY BIT + 1 STOP BIT.
ODD parity : The total of D0 + D1 + D7 + Parity bit equals an odd number.

3. Command Block Format (CMD Block)

3-1. VTP Command

The communication between the CONTROLLER and the DEVICE is composed of CMD-1 + DATA COUNT, CMD-2 + DATA and CHECKSUM, and is transmitted from CMD-1 + DATA COUNT in order.

When the DATA COUNT is zero, the DATA is not transmitted.

When it is not zero, the DATA corresponded with the value is inserted between CMD-2 and CHECKSUM.

The command block can be illustrated as shown.

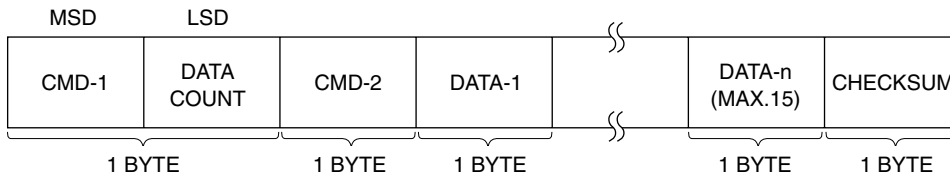

CMD-1 : CMD-1 classifies the command into the main groups which indicates the function and direction of the data words to follow.

Contents of CMD-1

CMD-1	Function	Direction	
		Controller	Device
0	SYSTEM CONTROL	→	
1	SYSTEM CONTROL RETURN	←	
2	TRANSPORT CONTROL	→	
4	PRESET & SELECT CONTROL	→	
6	SENSE REQUEST	→	
7	SENSE RETURN	←	

DATA COUNT : DATA COUNT indicates the number of data bytes that are added to the command. (0 to FH)

CMD-2 : Specifies the respective commands.

DATA : The number of data bytes and their contents are defined by the respective commands.

CHECKSUM : The CHECKSUM is the lower eight value of the sum of the data bytes from the first byte to the last byte immediately before CHECKSUM. It is used to check the errors that are incurred by the data communication.

3-2. DSR-DR1000/A DISK Command

ID	DC	CMD1	CMD2	DATA	CS
1byte	1byte	1byte	1byte	0 to 255byte	1byte

a. ID : Code undefined as CMD1 of Sony VTR 9PIN PROTOCOL.

0x30 and 0x31 are designated as an ID of the extension command for DISK.

ID:0x30 : Indicates that it is a single block with less than 256-byte DATA length. Or it indicates that it is the last block when transmitting a command by dividing into multiple blocks.

ID:0x31 : Indicates that there is a continuous block when transmitting a command by dividing it into multiple blocks.

Example: When transmitting a command with data consisting of 256-byte DATA length

First block

0x31 ^^^	0xFF	CMD1	CMD2	DATA BYTE0	BYTE1	BYTE254	CS
-------------	------	------	------	---------------	-------	-------	---------	----

Second block

0x30 ^^^	0xFF	CMD1	CMD2	DATA BYTE255	CS
-------------	------	------	------	-----------------	----

b. DC : Number of bytes of DATA (0 to 255)

c. CMD1: Specifies the categories of commands.

Contents of CMD-1

CMD1	FUNCTION	DIRECTION
0x00	VTR SYSTEM CONTROL	T → R
0x01	VTR SYSTEM CONTROL RETURN	T ← R
0x02	VTR TRANSPORT CONTROL	T → R
0x04	VTR PRESET & SELECT CONTROL	T → R
0x06	VTR SENSE REQUEST	T → R
0x07	VTR SENSE RETURN	T ← R
0x10	SYSTEM PRESET	T → R
0x11	SYSTEM STATUS SENSE	T → R
0x12	SYSTEM STATUS	T ← R
0x13	DRIVE CONTROL/PRESET	T → R
0x14	DRIVE STATUS SENSE	T → R
0x15	DRIVE STATUS	T ← R
0x16	PORT CONTROL/PRESET	T → R
0x17	PORT STATUS SENSE	T → R
0x18	PORT STATUS	T ← R
0x19	FILE CONTROL/PRESET	T → R
0x1A	FILE STATUS SENSE	T → R
0x1B	FILE STATUS	T ← R
0xFx	DEVICE DEPENDENT COMMAND	T → R T ← R

T:CONTROLLING DEVICE
R:CONTROLLED DEVICE

[System related commands]

0x00 to 0x07 are the ones that the upper four bits of CMD1 of the Sony VTR 9PIN PROTOCOL is shifted to four bits rightward. The content is the same as that of the Sony VTR 9PIN PROTOCOL. 0x10 to 0x12 are in a category related to parameter settings and requests unique to the device.

[Drive related commands]

0x13 to 0x15 are in a category related to controls or parameter settings and requests for the DISK DEVICE that the device has. Drive ID is added to all the commands in the category, and the drive ID specifies a target DISK DEVICE.

[Port related commands]

0x16 to 0x18 are in a category related to controls or parameter settings and requests for the logical port that the device has. Port ID is added to all the commands in the category, and the port ID specifies a target port.

[File related commands]

0x19 to 0x1B are in a category related to controls or parameter settings and requests for the opened file. File handle is added to all the commands in this category, and the file handle specifies a target file.

[Device dependent commands]

0xFx (0xF0 to 0xFF) is in a category that allows defining the commands that depends on the device.

However, some commands do not fall into these categories.

d. CMD2 : Assigns individual commands according to the following code category list.

- CMD2 code category list

CMD2 (0x00 to 0xFF)

```
|
+----- Operation related codes (0x00 to 0x7F)
|   |
|   +-----Basic operation, open operation (0x00 to 0x3F)
|   |
|   +-----AUTO/MACRO operation (0x40 to 0x5F)
|   |
|   +-----Machine, maintenance, and service related codes (0x60 to 0x6F)
|   |
|   +-----Other, special operation (0x70 to 0x7F)
+----- Preset related codes (0x80 to 0xFF)
|
+-----FILE related codes (0x80 to 0x8F)
|
+-----AUTO/MACRO MODE setting (0x90 to 0x9F)
|
+-----VIDEO related codes (0xA0 to 0xAF)
|
+-----AUDIO related codes (0xB0 to 0xBF)
|
+-----TC related codes (0xC0 to 0xCF)
|
+----- System parameter setting (0xD0 to 0xDF)
|
+----- Maintenance and service related codes (0xE0 to 0xEF)
|
+-----Other, special mode setting (0xF0 to 0xFF)
```

Individual codes are categorized as follows according to whether they are odd and even:

However, some codes do not fall into these categories depending on the content of commands.

Even (LSB=0) **** OFF, playback Odd (LSB=1) **** ON, recording

e. DATA : Additional data of individual commands (total of 255 bytes at maximum).

f. CS (CHECKSUM) : CS is the lower eight value of the sum of the data bytes from the first byte (ID) to the last byte immediately before CS.

4. Connector Pin Assignment

Interface connector : 9 pin D-subminiature female (D-9S)

The pin assignment for the CONTROLLER and the DEVICE is as shown in the following table.
Among the DSR series VTRs, the VTRs (DSR-85/85P) that have the built-in CONTROLLER function, obtain the following CONTROLLER pin assignment when they execute the QSDI dubbing and also when the RECORDER lamp or the PLAYER lamp turns on the control panel.

Except for that, it's become pin assignment of DEVICE.

The VTR not had the function as CONTROLLER (DSR-60/60P) is always become pin assignment of DEVICE.

Signal Pin	Controller	Device
1	Frame Ground	Frame Ground
2	Receive A	Transmit A
3	Transmit B	Receive B
4	Transmit Common	Receive Common
5	Spare	Spare
6	Receive Common	Transmit Common
7	Receive B	Transmit B
8	Transmit A	Receive A
9	Frame Ground	Frame Ground

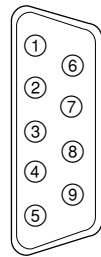

External view

A and B are defined as shown below.

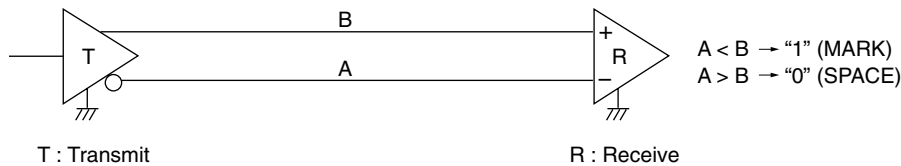

5. Communication Protocol

- 1) All communication between the CONTROLLER and the DEVICE will be under the direct supervision of the CONTROLLER.
When the DEVICE receives the COMMAND sent from CONTROLLER, the following COMMAND is returned.
 - In the case that the DEVICE receives the COMMAND not required the data
..... ACK
 - In the case that the DEVICE receives the COMMAND required the data
..... COMMAND + DATA
 - In the case that the error communication is detected or the undefined COMMAND is received
..... NAK + ERROR DATA
- 2) The CONTROLLER is not transmit additional COMMAND blocks to a DEVICE prior to receivers an appropriate response to a previous COMMAND block.
- 3) The CONTROLLER is not interrupt transmission of a byte in a COMMAND block for more than 10 ms. A DEVICE detecting an interruption of a byte in a COMMAND block that exceeds 10 ms. CONTROLLER execute a TIME-OUT error sequence.
A DEVICE will void the receiving COMMAND block and transmit a NAK (TIME OUT).
- 4) The DEVICE, following receipt of a COMMAND block from the CONTROLLER will transmit a response within 9 ms.
Therefore if the CONTROLLER cannot receive the appropriate response from the DEVICE within 10 ms. After performing the COMMAND block transmission, it will execute as the communication is not performed under the normal condition, and it will process as necessary.
- 5) The DEVICE, upon detection of an error, it will immediately transmit a NAK to the CONTROLLER. (The contents of an error is shown on the COMMAND tables.)
The CONTROLLER, upon receipt of NAK, it will immediately stop transmission of the COMMAND block. The DEVICE, following transmission of NAK, it will receive a subsequent COMMAND block within 10 ms. (except NAK UNDEFINED COMMAND) and will process as necessary.

6. Command

The marks shown in the tables mean the following contents.

- 1) ○ marked COMMAND's model can correspond. If the contents are in the RETURN column, RETURN + DATA will be returned.
If the contents are not in the RETURN column, "10•01 : ACK" will be returned.
- 2) △ marked COMMAND returns ACK as RETURN, but does not operate.
- 3) × marked COMMAND does not correspond and returns "11.12.01 : NAK UNDEFINED COMMAND."
- 4) For details of the commands for disk recorders such as DSR-DR1000/A, refer to Section 6-2. Command Table (for Disk Recorder).

6-1. Command Table (for Cassette Recorder/Player)

Command	Return	HVR-1500/A	HVR-1500	HVR-1500A	DSR-2000/A	DSR-1800/A	DSR-1600/A	DSR-1500/A	DSR-85/80	DSR-70A	DSR-70	DSR-60
		(DVCAM)	(HDV)	(HDV)								
00•0C : LOCAL DISABLE	○ → ACK × → NAK	○	○	○	○	○	○	○	○	○	○	○
00•11 : DEVICE TYPE REQUEST	12•11 : DEVICE TYPE	○	○	○	○	○	○	○	○	○	○	○
00•1D : LOCAL ENABLE	○ → ACK × → NAK	○	○	○	○	○	○	○	○	○	○	○
20•00 : STOP	○/△ → ACK × → NAK	○	○	○	○	○	○	○	○	○	○	○
20•01 : PLAY		○	○	○	○	○	○	○	○	○	○	○
20•02 : REC		○	○	○	○	○	△	○	○	○	○	△
20•04 : STANDBY OFF		○	○	○	○	○	○	○	○	○	○	○
20•05 : STANDBY ON		○	○	○	○	○	○	○	○	○	○	○
20•0D : DMC START		×	×	×	○	×	×	×	×	○	×	×
20•0F : EJECT		○	○	○	○	○	○	○	○	○	○	○
20•10 : FAST FWD		○	○	○	○	○	○	○	○	○	○	○
2X•11 : JOG FWD		○	○	○	○	○	○	○	○	○	○	○
2X•12 : VAR FWD		○	○	○	○	○	○	○	○	○	○	○
2X•13 : SHUTTLE FWD		○	○	○	○	○	○	○	○	○	○	○
20•20 : REWIND		○	○	○	○	○	○	○	○	○	○	○
2X•21 : JOG REV		○	○	○	○	○	○	○	○	○	○	○
2X•22 : VAR REV		○	○	○	○	○	○	○	○	○	○	○
2X•23 : SHUTTLE REV		○	○	○	○	○	○	○	○	○	○	○
20•30 : PREROLL		○	○	○	○	○	○	○	○	○	○	○
24•31 : CUE UP WITH DATA		○	○	○	○	○	○	○	○	○	○	○
24•32 : SYNC POINT PREROLL		○	○	○	○	○	○	○	○	○	○	○
24•34 : SYNC PLAY		○	○	○	○	○	○	○	○	○	○	○
21•38 : PROGRAM PLAY +		×	×	×	○	×	×	×	×	○	×	×
21•39 : PROGRAM PLAY -		×	×	×	○	×	×	×	×	○	×	×
20•3C : DMC PREROLL		×	×	×	○	×	×	×	×	○	×	×
20•40 : PREVIEW		○	△	△	○	○	△	○	○	○	○	△
20•41 : REVIEW		○	△	△	○	○	△	○	○	○	○	△

Command	Return	HVR-1500/A	HVR-1500	HVR-1500A	DSR-2000/A	DSR-1800/A	DSR-1600/A	DSR-1500/A	DSR-85/80	DSR-70A	DSR-70	DSR-60
		(DVCAM)	(HDV)	(HDV)								
20•42 : AUTO EDIT	O/Δ → ACK X → NAK	○	△	△	○	○	△	○	○	○	○	△
20.4B : DMC RUN		×	×	×	○	×	×	×	×	○	×	×
20•4C : DMC PREVIEW		×	×	×	○	×	×	×	×	○	×	×
20•52 : TENSION RELEASE		○	○	○	○	○	○	○	○	○	○	○
20•54 : ANTI-CLOG TIMER DISABLE		○	○	○	○	○	○	○	○	○	○	○
20•55 : ANTI-CLOG TIMER ENABLE		○	○	○	○	○	○	○	○	○	○	○
2X•5C : DMC SET FWD		×	×	×	○	×	×	×	×	○	×	×
2X•5D : DMC SET REV		×	×	×	○	×	×	×	×	○	×	×
20•60 : FULL EE OFF		○	○	○	○	○	△	○	○	○	○	△
20•61 : FULL EE ON		○	○	○	○	○	△	○	○	○	○	△
20•63 : SELECT EE ON		○	△	△	○	○	△	○	○	○	○	△
20•64 : EDIT OFF		○	△	△	○	○	△	○	○	○	○	△
20•65 : EDIT ON		○	△	△	○	○	△	○	○	○	○	△

Command	Return	HVR-1500/A	HVR-1500	HVR-1500A	DSR-2000/A	DSR-1800/A	DSR-1600/A	DSR-1500/A	DSR-85/80	DSR-70A	DSR-70	DSR-60
		(DVCAM)	(HDV)	(HDV)								
44•00 : TIMER-1 PRESET	○/△ → ACK × → NAK	○	○	○	○	○	○	○	○	○	○	○
44•04 : TIME CODE PRESET		○	○	○	○	○	△	○	○	○	○	△
4X•05 : USER'S BIT PRESET		○	○	○	○	○	△	○	○	○	○	△
40•08 : TIMER-1 RESET		○	○	○	○	○	○	○	○	○	○	○
40•10 : IN ENTRY		○	○	○	○	○	○	○	○	○	○	○
40•11 : OUT ENTRY		○	○	○	○	○	○	○	○	○	○	○
40•12 : A IN ENTRY		○	○	○	○	○	○	○	○	○	○	○
40•13 : A OUT ENTRY		○	○	○	○	○	○	○	○	○	○	○
44•14 : IN DATA PRESET		○	○	○	○	○	○	○	○	○	○	○
44•15 : OUT DATA PRESET		○	○	○	○	○	○	○	○	○	○	○
44•16 : A IN DATA PRESET		○	○	○	○	○	○	○	○	○	○	○
44•17 : A OUT DATA PRESET		○	○	○	○	○	○	○	○	○	○	○
40•18 : IN SHIFT +		○	○	○	○	○	○	○	○	○	○	○
40•19 : IN SHIFT -		○	○	○	○	○	○	○	○	○	○	○
40•1A : OUT SHIFT +		○	○	○	○	○	○	○	○	○	○	○
40•1B : OUT SHIFT -		○	○	○	○	○	○	○	○	○	○	○
40•1C : A IN SHIFT +		○	○	○	○	○	○	○	○	○	○	○
40•1D : A IN SHIFT -		○	○	○	○	○	○	○	○	○	○	○
40•1E : A OUT SHIFT +		○	○	○	○	○	○	○	○	○	○	○
40•1F : A OUT SHIFT -		○	○	○	○	○	○	○	○	○	○	○
40•20 : IN RESET		○	○	○	○	○	○	○	○	○	○	○
40•21 : OUT RESET		○	○	○	○	○	○	○	○	○	○	○
40•22 : A IN RESET		○	○	○	○	○	○	○	○	○	○	○
40•23 : A OUT RESET		○	○	○	○	○	○	○	○	○	○	○
40•24 : IN RECALL		○	○	○	○	○	○	○	○	○	○	○
40•25 : OUT RECALL		○	○	○	○	○	○	○	○	○	○	○
40•26 : A IN RECALL		○	○	○	○	○	○	○	○	○	○	○
40•27 : A OUT RECALL		○	○	○	○	○	○	○	○	○	○	○
40•2D : LOST LOCK RESET		○	○	○	○	○	○	○	○	○	○	○
4X•30 : EDIT PRESET		○	△	△	○	○	△	○	○	○	○	△
44•31 : PREROLL TIME PRESET		○	○	○	○	○	○	○	○	○	○	○
41•32 : TAPE/AUTO SELECT		○	○	○	○	○	△	○	○	○	○	△
41•36 : TIMER MODE SELECT		○	○	○	○	○	○	○	○	○	○	○
41•37 : INPUT CHECK		○	○	○	○	○	△	○	○	○	○	△
41•3D : PREREC MODE SELECT		×	×	×	○	×	×	×	×	○	×	×
43•3F : Δ t REC/PLAY PRESET		△	△	△	△	△	△	△	85 : ○ 80 : △	○	△	△
40•40 : AUTO MODE OFF		○	○	○	○	○	○	○	○	○	○	○
40•41 : AUTO MODE ON		○	○	○	○	○	○	○	○	○	○	○
40•44 : AUDIO SPLIT OFF		○	△	△	○	○	○	○	○	○	○	○
40•45 : AUDIO SPLIT ON		○	△	△	○	○	○	○	○	○	○	○

Command	Return	HVR-1500/A	HVR-1500	HVR-1500A	DSR-2000/A	DSR-1800/A	DSR-1600/A	DSR-1500/A	DSR-85/80	DSR-70A	DSR-70	DSR-60	
		(DVCAM)	(HDV)	(HDV)									
40•46 : VARIABLE MEMORY OFF	○/△ → ACK × → NAK	×	×	×	○	×	×	×	×	△	×	×	
40•47 : VARIABLE MEMORY ON		×	×	×	○	×	×	×	×	△	×	×	
42•50 : DA INPUT SELECT		○	○	○	○	○	△	○	○	○	○	○	△
4X•54 : EXTENDED DA INPUT SELECT		○	○	○	○	○	△	○	○	○	○	○	△
41•58 : DA SAMPLING FREQ PRESET		○	△	△	○	○	△	○	○	○	○	○	△
41•60 : VITC BYPASS		○	△	△	○	○	△	○	×	○	○	×	×
42•61 : TCG MODE SELECT		○	○	○	○	○	△	○	○	○	○	○	△
42•70 : VIDEO INPUT SELECT		○	○	△	○	○	△	○	○	○	○	○	△
41•9E : SUPERIMPOSE		○	○	○	○	○	○	○	○	○	○	○	○
4X•AE : AUDIO MONITOR CHANNEL SELECT		○	○	○	○	○	○	○	×	○	○	×	×
40•C0 : TIMELINE STOP		○	○	○	○	○	○	○	○	○	○	○	○
40•C1 : TIMELINE RUN		○	○	○	○	○	○	○	○	○	○	○	○
44•C3 : TIMELINE PRESET		○	○	○	○	○	○	○	○	○	○	○	○
4X•C4 : DEFINE EVENT		○	○	○	○	○	○	○	○	○	○	○	○
42•C5 : CLEAR EVENT		○	○	○	○	○	○	○	○	○	○	○	○
41•CB : BREAK		○	○	○	○	○	○	○	○	○	○	○	○

Command	Return	HVR-1500/A (DVCAM)	HVR-1500 (HDV)	HVR-1500A (HDV)	DSR-2000/A	DSR-1800/A	DSR-1600/A	DSR-1500/A	DSR-85/80	DSR-70A	DSR-70	DSR-60
61•0A : TC GEN DATA SENSE	74•08 : GEN TIME DATA	○	○	○	○	○	×	○	○	○	○	×
	74•09 : GEN UB DATA	○	○	○	○	○	×	○	○	○	○	×
	78•08 : GEN TC & UB DATA	○	○	○	○	○	×	○	○	○	○	×
61•0C : CURRENT TIME SENSE	74•00 : TIMER-1 DATA	○	○	○	○	○	○	○	○	○	○	○
	74•01 : TIMER-2 DATA	○	○	○	○	○	○	○	○	○	○	○
	74•04 : LTC TIME DATA	○	○	○	○	○	○	○	○	○	○	○
	78•04 : LTC TIME & UB DATA	○	○	○	○	○	○	○	○	○	○	○
	74•05 : LTC UB DATA	○	○	○	○	○	○	○	○	○	○	○
	74•06 : VITC TIME DATA	○	×	×	○	○	○	○	×	○	×	×
	78•06 : VITC TIME & UB DATA	○	×	×	○	○	○	○	×	○	×	×
	74•07 : VITC UB DATA	○	×	×	○	○	○	○	×	○	×	×
	74•14 : LTC INTERPOLATED TIME DATA	○	○	○	○	○	○	○	○	○	○	○
	78•14 : LTC INTERPOLATED TIME & UB DATA	○	○	○	○	○	○	○	○	○	○	○
	74•16 : VITC HOLD TIME DATA	○	×	×	○	○	○	○	×	○	×	×
	78•16 : VITC HOLD TIME & UB DATA	○	×	×	○	○	○	○	×	○	×	×
70•0D : REQUEST TIME DATA MISSING	○	○	○	○	○	○	○	○	○	○	○	
60•10 : IN DATA SENSE	74•10 : IN DATA	○	○	○	○	○	○	○	○	○	○	○
60•11 : OUT DATA SENSE	74•11 : OUT DATA	○	○	○	○	○	○	○	○	○	○	○
60•12 : A IN DATA SENSE	74•12 : A IN DATA	○	○	○	○	○	○	○	○	○	○	○
60•13 : A OUT DATA SENSE	74•13 : A OUT DATA	○	○	○	○	○	○	○	○	○	○	○
60•20 : STATUS SENSE	7X•20 : STATUS DATA	○	○	○	○	○	○	○	○	○	○	○
60•2E : COMMAND SPEED SENSE	71•2E : COMMAND SPEED DATA	○	○	○	○	○	○	○	○	○	○	○
60•2F : VAR MEM SPEED SENSE	71•2F : VAR MEM SPEED DATA	×	×	×	○	×	×	×	×	○	×	×
6X•30 : EDIT PRESET SENSE	7X•30 : EDIT PRESET DATA	○	○	○	○	○	○	○	○	○	○	○
60•31 : PREROLL TIME SENSE	74•31 : PREROLL TIME DATA	○	○	○	○	○	○	○	○	○	○	○
60•32 : TAPE/AUTO SENSE	71•32 : TAPE/AUTO STATUS DATA	○	○	○	○	○	○	○	○	○	○	○
60•36 : TIMER MODE SENSE	71•36 : TIMER MODE DATA	○	○	○	○	○	○	○	○	○	○	○
60•3F : Δt REC/PLAY PRESET SENSE	73•3F : Δt REC/PLAY\ PRESET DATA	○	○	○	○	○	○	○	○	○	○	○
60•50 : DA INPUT SENSE	71•50 : DA INPUT STATUS	○	○	○	○	○	×	○	○	○	○	×
6X•54 : EXTENDED DA INPUT SENSE	7X•54 : EXTENDED DA INPUT STATUS	○	○	○	○	○	×	○	○	○	○	×
60•58 : DA SAMPLING FREQ SENSE	71•58 : DA SAMPLING FREQ STATUS	○	○	○	○	○	×	○	○	○	○	×
60•60 : VITC BYPASS SENSE	71•60 : VITC BYPASS STATUS	○	○	○	○	○	○	○	×	○	×	×
60•61 : TCG MODE SENSE	72•61 : TCG MODE	○	○	○	○	○	×	○	○	○	○	×

Command	Return	HVR-1500/A (DVCAM)	HVR-1500 (HDV)	HVR-1500A (HDV)	DSR-2000/A	DSR-1800/A	DSR-1600/A	DSR-1500/A	DSR-85/80	DSR-70A	DSR-70	DSR-60
60•70 : VIDEO INPUT SENSE	72•70 : VIDEO INPUT STATUS	○	○	○	○	○	×	○	○	○	○	×
60•9E : SUPERIMPOSE SENSE	71•9E : SUPERIMPOSE STATUS	○	○	○	○	○	○	○	○	○	○	○
60•AE : AUDIO MONITOR	74•AE : AUDIO MONITOR CHANNEL STATUS	○	○	○	○	○	○	○	×	○	×	×
60•C2 : TIMELINE SOURCE SENSE	71•C2 : TIMELINE SOURCE	○	○	○	○	○	○	○	○	○	○	○
60•C3 : TIMELINE TIME SENSE	75•C3 : TIMELINE TIME	○	○	○	○	○	○	○	○	○	○	○
62•C4 : EVENT DATA SENSE	7X•C4 : EVENT DATA	○	○	○	○	○	○	○	○	○	○	○
60•C6 : TIMELINE STATUS SENSE	75•C6 : TIMELINE STATUS	○	○	○	○	○	○	○	○	○	○	○
61•C7 : EVENT QUEUE SENSE	7X•C7 : EVENT QUEUE	○	○	○	○	○	○	○	○	○	○	○
61•C8 : UNSUCCESSFUL EVENT SENSE	7X•C8 : UNSUCCESSFUL EVENT	○	○	○	○	○	○	○	○	○	○	○

6-2. Command Table (for Disk Recorder)

“IN (R)” of DSR-DR1000/A indicates the RECORDER side during the simultaneous record/playback (REMOTE I/F of INTERFACE SELECT is set to “9PIN (DUAL)”).

In the same way, “OUT (P)” of DSR-DR1000/A indicates the PLAYER side.

Note

The IN points and the OUT points of the program playback that are set using the “← (IN)” or “→ (OUT)” of the front panel are different from the IN points and the OUT points that are set from the 9-pin remote control unit. When the IN DATA SENSE command and the OUT DATA SENSE command that are issued from the 9-pin remote control unit are sent to the DSR-DR1000/A, the IN points and the OUT points that are by this operation will not be returned.

Command	Return	DSR-DR1000/A	DSR-DR1000/A IN (R)	DSR-DR1000/A OUT (P)
00•0C : LOCAL DISABLE	○ → ACK × → NAK	○	○*1	○*1
00•11 : DEVICE TYPE REQUEST	12•11 : DEVICE TYPE	○	○	○
00•1D : LOCAL ENABLE	○ → ACK × → NAK	○	○	○
20•00 : STOP	○/△ → ACK × → NAK	○	○	○
20•01 : PLAY		○	△	○
20•02 : REC		○	○	△
20•04 : STANDBY OFF		○	○	○
20•05 : STANDBY ON		○	○	○
20•0D : DMC START		○	△	○
20•0F : EJECT		△	△	△
20•10 : FAST FWD		○	△	○
2X•11 : JOG FWD		○	△	○
2X•12 : VAR FWD		○	△	○
2X•13 : SHUTTLE FWD		○	△	○
20•20 : REWIND		○	△	○
2X•21 : JOG REV		○	△	○
2X•22 : VAR REV		○	△	○
2X•23 : SHUTTLE REV		○	△	○
20•30 : PREROLL		○	△	○
24•31 : CUE UP WITH DATA		○	△	○
24•32 : SYNC POINT PREROLL		○	△	○
24•34 : SYNC PLAY		○	△	○
21•38 : PROGRAM PLAY +		○	△	○
21•39 : PROGRAM PLAY -		○	△	○
20•3C : DMC PREROLL		○	△	○
20•40 : PREVIEW		△	△	△
20•41 : REVIEW		△	△	△
20•42 : AUTO EDIT		△	△	△
20•4B : DMC RUN		○	△	○
20•4C : DMC PREVIEW		○	△	○
20•52 : TENSION RELEASE		○	○	○
20•54 : ANTI-CLOG TIMER DISABLE		△	△	△

*1 : Both of the RECORDER and the PLAYER side can be set to Disable independently.

Command	Return	DSR-DR1000/A	DSR-DR1000/A IN (R)	DSR-DR1000/A OUT (P)
20•55 : ANTI-CLOG TIMER ENABLE	O/△ → ACK × → NAK	△	△	△
2X•5C : DMC SET FWD		○	△	○
2X•5D : DMC SET REV		○	△	○
20•60 : FULL EE OFF		○	△	○*2
20•61 : FULL EE ON		○	△	○*2
20•63 : SELECT EE ON		△	△	○*2
20•64 : EDIT OFF		△	△	△
20•65 : EDIT ON		△	△	△

*2 : When both of the R and P indicators of the LINE OUT SELECT on the front panel light, output can be selected from the (P) side port.

Command	Return	DSR-DR1000/A	DSR-DR1000/A IN (R)	DSR-DR1000/A OUT (P)
44•00 : TIMER-1 PRESET	O/Δ → ACK X → NAK	○	○*3	○*3
44•04 : TIME CODE PRESET		○	○	△
4X•05 : USER'S BIT PRESET		○	○	△
40•08 : TIMER-1 RESET		○	○*3	○*3
40•10 : IN ENTRY		○	○*4	○*4
40•11 : OUT ENTRY		○	○*4	○*4
40•12 : A IN ENTRY		○	○*4	○*4
40•13 : A OUT ENTRY		○	○*4	○*4
44•14 : IN DATA PRESET		○	○*4	○*4
44•15 : OUT DATA PRESET		○	○*4	○*4
44•16 : A IN DATA PRESET		○	○*4	○*4
44•17 : A OUT DATA PRESET		○	○*4	○*4
40•18 : IN SHIFT +		○	○*4	○*4
40•19 : IN SHIFT –		○	○*4	○*4
40•1A : OUT SHIFT +		○	○*4	○*4
40•1B : OUT SHIFT –		○	○*4	○*4
40•1C : A IN SHIFT +		○	○*4	○*4
40•1D : A IN SHIFT –		○	○*4	○*4
40•1E : A OUT SHIFT +		○	○*4	○*4
40•1F : A OUT SHIFT –		○	○*4	○*4
40•20 : IN RESET		○	○*4	○*4
40•21 : OUT RESET		○	○*4	○*4
40•22 : A IN RESET		○	○*4	○*4
40•23 : A OUT RESET		○	○*4	○*4
40•24 : IN RECALL		○	○*4	○*4
40•25 : OUT RECALL		○	○*4	○*4
40•26 : A IN RECALL		○	○*4	○*4
40•27 : A OUT RECALL		○	○*4	○*4
40•2D : LOST LOCK RESET		○	○	○
4X•30 : EDIT PRESET		△	△	△
44•31 : PREROLL TIME PRESET		○	○*3	○*3
41•32 : TAPE/AUTO SELECT		○	○	○
41•33 : SERVO REFERENCE SELECT		△	△	△
41•36 : TIMER MODE SELECT		○	○	○
41•37 : INPUT CHECK		○	△*5	△*5
41•3D : PREREAD MODE SELECT		X	X	X
43•3F : Δ t REC/PLAY PRESET		△	△	△
40•40 : AUTO MODE OFF		○	○	○
40•41 : AUTO MODE ON		○	○	○
40•44 : AUDIO SPLIT OFF		○	○	○

*3 : The (R) side and the (P) side can be set to PRESET independently.

*4 : The (P) side can be set to the same setting as in the ordinary VTR. It jumps to these points at the event of Preroll.

The (R) side can only save the set data, and cannot perform the Preroll operation. It returns the set data to SENSE.

*5 : When both of the R and P indicators of the LINE OUT SELECT on the front panel light, the forced EE mode can be set from the (P) side.

Command	Return	DSR-DR1000/A	DSR-DR1000/A IN (R)	DSR-DR1000/A OUT (P)
40•45 : AUDIO SPLIT ON	○/△ → ACK × → NAK	○	○	○
40•46 : VARIABLE MEMORY OFF		○	△	△
40•47 : VARIABLE MEMORY ON		○	△	△
42•50 : DA INPUT SELECT		○	○	○
4X•54 : EXTENDED DA INPUT SELECT		○	○	○
41•58 : DA SAMPLING FREQ PRESET		○	○	○
41•60 : VITC BYPASS		○	○	○
42•61 : TCG MODE SELECT		○	○	○
42•70 : VIDEO INPUT SELECT		○	○	○
41•9E : SUPERIMPOSE		○	○	○
4X•AE: AUDIO MONITOR CHANNEL SELECT		○	○	○
40•C0 : TIMELINE STOP		○	○	○
40•C1 : TIMELINE RUN		○	○	○
44•C3 : TIMELINE PRESET		○	○	○
4X•C4: DEFINE EVENT		○	○	○
42•C5 : CLEAR EVENT		○	○	○
41•CB : BREAK		○	○	○

Command	Return	DSR-DR1000/A	DSR-DR1000/A IN (R)	DSR-DR1000/A OUT (P)
61•0A : TC GEN DATA SENSE	74•08 : GEN TIME DATA	○	○	○
	74•09 : GEN UB DATA	○	○	○
	78•08 : GEN TC & UB DATA	○	○	○
61•0C : CURRENT TIME SENSE	74•00 : TIMER-1 DATA	○	○*6	○*6
	74•01 : TIMER-2 DATA	○	○*6	○*6
	74•04 : LTC TIME DATA	○	○*6	○*6
	78•04 : LTC TIME & UB DATA	○	○*6	○*6
	74•05 : LTC UB DATA	○	○*6	○*6
	74•06 : VITC TIME DATA	○	○*6	○*6
	78•06 : VITC TIME & UB DATA	○	○*6	○*6
	74•07 : VITC UB DATA	○	○*6	○*6
	74•14 : LTC INTERPOLATED TIME DATA	○	○*6	○*6
	78•14 : LTC INTERPOLATED TIME & UB DATA	○	○*6	○*6
	74•16 : VITC HOLD TIME DATA	○	○*6	○*6
	78•16 : VITC HOLD TIME & UB DATA	○	○*6	○*6
	70•0D : REQUEST TIME DATA MISSING	○	○*6	○*6
60•10 : IN DATA SENSE	74•10 : IN DATA	○	○	○
60•11 : OUT DATA SENSE	74•11 : OUT DATA	○	○	○
60•12 : A IN DATA SENSE	74•12 : A IN DATA	○	○	○
60•13 : A OUT DATA SENSE	74•13 : A OUT DATA	○	○	○
60•20 : STATUS SENSE	7X•20 : STATUS DATA	○	○	○
60•2E : COMMAND SPEED SENSE	71•2E : COMMAND SPEED DATA	○	○*6	○*6
60•2F : VAR MEM SPEED SENSE	71•2F : VAR MEM SPEED DATA	○	○	○
6X•30 : EDIT PRESET SENSE	7X•30 : EDIT PRESET DATA	○	○	○
60•31 : PREROLL TIME SENSE	74•31 : PREROLL TIME DATA	○	○	○
60•32 : TAPE/AUTO SENSE	71•32 : TAPE/AUTO STATUS DATA	○	○	○
60•36 : TIMER MODE SENSE	71•36 : TIMER MODE DATA	○	○	○
60•3F : Δ t REC/PLAY PRESET SENSE	73•3F : Δ t REC/PLAY\ PRESET DATA	○	○	○
60•50 : DA INPUT SENSE	71•50 : DA INPUT STATUS	○	○	○
6X•54 : EXTENDED DA INPUT SENSE	7X•54 : EXTENDED DA INPUT STATUS	○	○	○
60•58 : DA SAMPLING FREQ SENSE	71•58 : DA SAMPLING FREQ STATUS	○	○	○
60•60 : VITC BYPASS SENSE	71•60 : VITC BYPASS STATUS	○	○	○
60•61 : TCG MODE SENSE	72•61 : TCG MODE	○	○	○

*6 : The respective values of the (R) side and the (P) side are returned respectively.

Command	Return	DSR-DR1000/A	DSR-DR1000/A IN (R)	DSR-DR1000/A OUT (P)
60•70 : VIDEO INPUT SENSE	72•70 : VIDEO INPUT STATUS	○	○	○
60•9E : SUPERIMPOSE SENSE	71•9E : SUPERIMPOSE STATUS	○	○	○
60•AE : AUDIO MONITOR	74•AE : AUDIO MONITOR CHANNEL STATUS	○	○	○
60•C2 : TIMELINE SOURCE SENSE	71•C2 : TIMELINE SOURCE	○	○	○
60•C3 : TIMELINE TIME SENSE	75•C3 : TIMELINE TIME	○	○	○
62•C4 : EVENT DATA SENSE	7X•C4 : EVENT DATA	○	○	○
60•C6 : TIMELINE STATUS SENSE	75•C6 : TIMELINE STATUS	○	○	○
61•C7 : EVENT QUEUE SENSE	7X•C7 : EVENT QUEUE	○	○	○
61•C8 : UNSUCCESSFUL EVENT SENSE	7X•C8 : UNSUCCESSFUL EVENT	○	○	○

6-3. Command Table (for DSR-DR1000/A Disk Command)

COMMAND					RETURN			
DC	C1	C2	D1		DC	C1	C2	D1
System Command								
00	10	40		VFL DOWNLOAD ENABLE	10	01		
XX	10	41		VFL DOWNLOAD DATA SET	10	01		
00	10	42		VFL DOWNLOAD DATA WRITE	10	01		
00	10	43		VFL DOWNLOAD DATA CLEAR	10	01		
04	11	D0		SYSTEM STATUS SENSE	XX	12	D0	
Drive Command								
XX	13	03		DELETE	10	01		
0X	14	81		FILE SYSTEM DATA SENSE	XX	15	81	
03	14	D0		DRIVE STATUS SENSE	XX	15	D0	
Port Command								
XX	16	00		OPEN PLAY	10	01		
01	17	00		FILE OPEN STATUS SENSE	0X	18	00	
File Command								
01	19	01		CLOSE	10	01		
03	1A	82		FILE ENTRY DATA SENSE	XX	1B	82	
02	1A	C0		CURRENT TIME SENSE	XX	1B	C0	

Both DSR-DR1000/A IN (R) and DSR-DR1000/A OUT (P) have the same function (receiving the same command).

7. Protocol Command

7-1. VTR Command

00•0C : LOCAL DISABLE

When receiving this command, all functions of the DEVICE will be disabled.

00•11 : DEVICE TYPE REQUEST

12•11 : DEVICE TYPE

The “00•11 : DEVICE TYPE REQUEST” command is used to ask the model of the DEVICE to be connected, and if the DEVICE receives this command, the “12•11 : DEVICE TYPE” with 2 bytes data will be sent back as a response.

Model	DATA-1	DATA-2
DSR-2000/2000P/2000A/2000AP	8X	14
DSR-1800/1800P/1800A/1800AP	8X	15
DSR-1600/1600P/1600A/1600AP	8X	16
DSR-1500/1500P/1500A/1500AP	8X	17
DSR-DR1000/DR1000P/DR1000A/DR1000AP	8X	18
DSR-85/85P	8X	10
DSR-80/80P	8X	11
DSR-70A/70AP	8X	13
DSR-70/70P	8X	13
DSR-60/60P	8X	12

NTSC Model : X=0
PAL Model : X=1

00•1D : LOCAL ENABLE

When receiving this command, the control panel operation will be enabled according to the DEVICE setting.

When the power of the DEVICE is turned on, it will be set to the LOCAL ENABLE state.

10•01 : ACK

When receiving this command, the DEVICE will send back this command as acknowledgement.

11•12 : NAK

When detecting the communication errors or receiving the undefined COMMAND, the CONTROLLER will send back this command as not-acknowledgement.

BIT-7 to BIT-0 of DATA-1 will be set in accordance with the contents.

[DATA-1]

BIT-7	BIT-6	BIT-5	BIT-4	BIT-3	BIT-2	BIT-1	BIT-0
TIME OUT	FRAMING ERROR	OVERRUN ERROR	PARITY ERROR		CHECKSUM ERROR	SOFTWARE OVERRUN	UNDEFINED COMMAND

20•00 : STOP

20•01 : PLAY

20•02 : REC

20•04 : STANDBY OFF

20•05 : STANDBY ON

When receiving one of the above commands, the DEVICE will be in the specified mode.

The “20•04 : STANDBY OFF” command is available only when the DEVICE is in STOP mode.

20•0D : DMC START : DMC=Dynamic Motion Control (=VAR MEMORY)
 This command is used to run the DEVICE from the present tape position at the speed that is stored by the “20•4B : DMC RUN” command.

20•0F : EJECT
 When receiving this command, the DEVICE ejects the cassette.

20•10 : FAST FWD
20•20 : REWIND
 When receiving this command, the DEVICE will become the specified mode.

2X•11 : JOG FWD
2X•12 : VAR FWD
2X•13 : SHUTTLE FWD
2X•21 : JOG REV
2X•22 : VAR REV
2X•23 : SHUTTLE REV

When receiving one of the above commands, the DEVICE will start running in accordance with speed data defined by the DATA-1 and the DATA-2.
 When only DATA-1 is given, (X=1) and the tape speed will be defined as follows.

$$\text{TAPE SPEED} = 10^{(N/32-2)}, N : \text{SPEED DATA (DECIMAL)}$$

Example)

TAPE SPEED	SPEED	DATA
STILL	0	(0H)
0.1 times normal speed	32	(20H)
1.0 times normal speed	64	(40H)
About 2.9 times normal speed	79	(4FH)

When setting more precise value than the tape speed defined by DATA-1, DATA-2 will be added, however, the precise value is a linear approximate value. (X=2)
 When both DATA-1 and DATA-2 are given, the tape speed will be defined as follows.

$$\text{TAPE SPEED} = 10^{(N/32-2)} + N' / 256 \{ 10^{[(N+1)/32-2]} - 10^{(N/32-2)} \}$$

N : SPEED DATA OF DATA-1 (DECIMAL)

N' : SPEED DATA OF DATA-2 (DECIMAL)

20•30 : PREROLL
 When receiving this command, the DEVICE will be prerolled to the tape position, that is, the value obtained by subtracting the time defined by the “44•31 : PREROLL TIME PRESET” command from the IN POINT data equivalent to the TIMER DATA or TIME CODE stored in the IN ENTRY memory by the “40•10 : IN ENTRY” command.

24•31 : CUE UP WITH DATA
 This command is used for cueing up the DEVICE to the position assigned by the time data of DATA-1 through DATA-4.
 A unit of respective data are as follows :

DATA-1		DATA-2		DATA-3		DATA-4	
10 Frame	1 Frame	10 Second	1 Second	10 Minute	1 Minute	10 Hour	1 Hour
MSD	LSD	MSD	LSD	MSD	LSD	MSD	LSD

24•32 : SYNC POINT PREROLL

The tape cueing is performed as the preliminary processing of the “24•34 : SYNC PLAY” command. The preroll time is determined by the value which is set by the “44•31 : PREROLL TIME PRESET” command.

[DATA-1 to DATA-4]

The sync point on a tape is specified.
For the data format, refer to “24•31: CUE UP WITH DATA”.

24•34 : SYNC PLAY

This command is used to enter playback after establishing the SYNC lock speed control between the SYNC time on the timeline and the sync point on tape. If the system fails to establish the sync lock speed control, the ABORT bit (DATA No. 9, bit-7) of STATUS is set to “1”.
The tape cue-up must have already been performed by executing the “24•32 : SYNC POINT PREROLL” command beforehand.

[DATA-1 to DATA-4]

The SYNC point on a tape is specified.
For the data format, refer to “24•31 : CUE UP WITH DATA”.

The SYNC time is defined as the trigger time by the “4X•C4 : DEFINE EVENT” command.

21•38 : PROGRAM PLAY +

21•39 : PROGRAM PLAY –

This command is used to play back the DEVICE at the tape speed to ±25.5 % at every 0.1 % step at the ×1 PLAY speed in accordance with the SPEED DATA that is specified by the DATA-1.

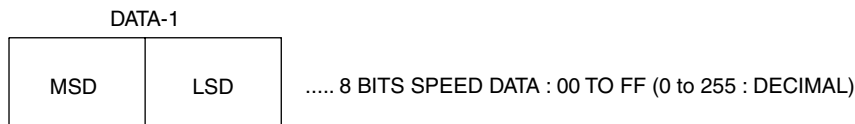

The relationship between the deviation (%) of the ×1 PLAY speed and the SPEED DATA is expressed with the following formula.

Deviation (%) = 0.1 × SPEED DATA (DECIMAL)

The DSR-2000/A is operated in units of 1 %.

20•3C : DMC PREROLL

This command is used for cueing up the DEVICE to the following point stored in the VAR MEMORY mode.

IN POINT – (stored first speed × PREROLL TIME)

20•40 : PREVIEW

20•41 : REVIEW

20•42 : AUTO EDIT

When receiving one of the above commands, the DEVICE will go into the specified mode.

20•4B : DMC RUN

This command is used to let the DEVICE perform a series of operations in the VAR MEMORY mode.

1. Cues up the tape to the following point.
Point IN – (set first speed × PREROLL TIME)
2. Runs at the set first speed to the point IN.
3. Stores the speed that is given by the PLAY, VAR FWD and VAR REV from the point IN.

20•4C : DMC PREVIEW

This command is used so that the DEVICE performs the following serial operations in the VAR MEMORY mode.

1. Cues up the tape to the following point.
Point IN – (stored first speed × PREROLL TIME)
2. Runs at the stored first speed to the point IN.
3. Reproduce the tape speed that is stored in the point IN.

20•52 : TENSION RELEASE

When receiving the above command in STILL mode of STOP or SHUTTLE/JOG/VAR, the DEVICE will be in the TENSION RELEASE mode.

20•54 : ANTI-CLOG TIMER DISABLE**20•55** : ANTI-CLOG TIMER ENABLE

“20•54 : ANTI-CLOG TIMER DISABLE” prohibits the operation of the ANTI-CLOG TIMER.

“20•55 : ANTI-CLOG TIMER ENABLE” permitted the operation of the ANTI-CLOG TIMER.

When turning on the power, ANTI-CLOG TIMER ENABLE mode is in the enable mode.

2X•5C : DMC SET FWD**2X•5D** : DMC SET REV

This command is used to preset the DEVICE as the set value of the first speed of “20•4B : DMC RUN” command during the VAR MEMORY mode.

The set value is specified in the DATA-1 of the following command. For the data format, refer to “2X•11 : JOG FWD”.

20•60 : FULL EE OFF**20•61** : FULL EE ON

These commands are used to set or clear all channels to EE mode.

When receiving this command, the DEVICE will start executing after passing the edit delay (three frames) time.

For the timing, refer to APPENDIX-1.

20•63 : SELECT EE ON

This command is used to set each EDIT PRESET channel assigned by the DATA-1 of the “41•30 : EDIT PRESET” command to the EE mode.

To clear the SELECT E-E mode, the “20•64 : EDIT OFF” command is used.

When receiving this command, the DEVICE will start executing after passing the edit delay (three frames) time.

For the timing, refer to APPENDIX-1.

20•64 : EDIT OFF

This command is used to clear the EDIT mode and also clear the SELECT EE mode.

When receiving this command, the DEVICE will start executing after passing the edit delay (three frames) time.

For the timing, refer to APPENDIX-1.

20•65 : EDIT ON

This command is used to set the DEVICE, which is running at the normal PLAY speed during the EDIT PRESET mode, to the EDIT mode.

When receiving this command, the DEVICE will start executing after passing the edit delay (three frames) time.

For the timing, refer to APPENDIX-1

44•00 : TIMER-1 PRESET

This command is used to preset the value, which has been given by the DATA-1 through DATA-4, to the TIMER-1 (CTL COUNTER) of the DEVICE.

The (Drop Frame/Non Drop Frame) mode of TIMER-1 is set corresponding to BIT-6 of DATA-1 as the following table.

DATA-1 BIT6	DF
0	OFF
1	ON

For the data format, refer to “24•31 : CUE UP WITH DATA”.

44•04 : TIME CODE PRESET

This command is used to preset the value, which has been given by the DATA-1 through DATA-4, to the TIME CODE of the time code generator.

For the data format, refer to “24•31 : CUE UP WITH DATA”.

The COLOR FRAMING (CF) and the DF/NDF mode of the TIME CODE GENERATOR are set according to BIT-7 and BIT-6 of DATA-1.

DATA-1 BIT7	CF
0	OFF
1	ON

DATA-1 BIT6	DF
0	OFF
1	ON

For the timing, refer to APPENDIX-2.

4X•05 : USER’S BIT PRESET

This command is used to preset the value, which has been given by the DATA-1 through DATA-4, to the USER’S BIT of the time code generator and is used to preset the corresponding bit inside the time data, that is given by DATA-5.

DATA-1		DATA-2		DATA-3		DATA-4	
2nd BINARY GROUP	1st BINARY GROUP	4th BINARY GROUP	3rd BINARY GROUP	6th BINARY GROUP	5th BINARY GROUP	8th BINARY GROUP	7th BINARY GROUP
MSD	LSD	MSD	LSD	MSD	LSD	MSD	LSD

[DATA-5 (Binary Group Flag)]

(NTSC)

BIT-7	BIT-6	BIT-5	BIT-4	BIT-3	BIT-2	BIT-1	BIT-0
0	0	0	0	0	BIT-59 (BG2)	BIT-58 (BG1)	BIT-43 (BG0)

(PAL)

BIT-7	BIT-6	BIT-5	BIT-4	BIT-3	BIT-2	BIT-1	BIT-0
0	0	0	0	0	BIT-43 (BG2)	BIT-58 (BG1)	BIT-27 (BG0)

For the timing, refer to APPENDIX-2.

40•08 : TIMER-1 RESET

This command is used to reset the TIMER-1 (COUNTER) to zero.

40•10 : IN ENTRY

40•11 : OUT ENTRY

40•12 : A IN ENTRY

40•13 : A OUT ENTRY

These commands are used to store the value of the TIMER or the TIME CODE data, which is displayed on the DEVICE, into the IN, OUT, A IN or A OUT memory as an IN POINT, OUT POINT, A IN POINT or A OUT POINT data.

44•14 : IN DATA PRESET

44•15 : OUT DATA PRESET

44•16 : A IN DATA PRESET

44•17 : A OUT DATA PRESET

These commands are used to preset the value, which has been given by the DATA-1 to DATA-4, into the IN, OUT, A IN or A OUT memory.

For the data format, refer to “24•31 : CUE UP WITH DATA”.

40•18 : IN SHIFT +

40•19 : IN SHIFT –

These commands are used to add or subtract the value of the TIME DATA, which has been stored as an IN POINT, by one frame.

40•1A : OUT SHIFT +

40•1B : OUT SHIFT –

These commands are used to add or subtract the value of the TIME DATA, which has been stored as an OUT POINT, by one frame.

40•1C : A IN SHIFT +

40•1D : A IN SHIFT –

These commands are used to add or subtract the value of the TIME DATA, which has been stored as an AUDIO IN POINT, by one frame.

40•1E : A OUT SHIFT +

40•1F : A OUT SHIFT –

These commands are used to add or subtract the value of the TIME DATA, which has been stored as an AUDIO OUT POINT, by one frame.

40•20 : IN RESET

40•21 : OUT RESET

40•22 : A IN RESET

40•23 : A OUT RESET

These commands are used to turn the IN, OUT, AUDIO IN or AUDIO OUT lamp to off.

40•24 : IN RECALL

40•25 : OUT RECALL

40•26 : A IN RECALL

40•27 : A OUT RECALL

These commands are used to turn the IN, OUT, AUDIO IN or AUDIO OUT lamp to on.

40•2D : LOST LOCK RESET

This command is used to reset the “DATA No. 8 BIT-6 : LOST LOCK” of the “7X•20 : STATUS DATA”.

The LOST LOCK status will be set when the capstan and drum servo is locked over 10 second, and then servo is unlocked in the PLAY, REC or EDIT mode.

4X•30 : EDIT PRESET

This command is used to select the edit mode and the video/audio preset channels.

The DEVICE sets all channels to “1” when the ASSEMBLE mode is selected.

[DATA-1]

BIT-7	BIT-6	BIT-5	BIT-4	BIT-3	BIT-2	BIT-1	BIT-0
	INSERT	ASSEMBLE	VIDEO		TIME CODE	A2	A1

[DATA-2]

BIT-7	BIT-6	BIT-5	BIT-4	BIT-3	BIT-2	BIT-1	BIT-0
				DA4	DA3	DA2	DA1

1 : EDIT PRESET ON
0 : EDIT PRESET OFF

In the case of “41•30” command, the channel to be preset by BIT-1 and BIT-0 of DATA-1 depends on the setting A1 EDIT CH and A2 EDIT CH.

In the case of “42•30” command, the setting of A1 EDIT CH, A2 EDIT CH or the setup menu becomes invalid, and the preset channel is selected according to the contents of DATA-1 and DATA-2.

When receiving this command during editing or rehearsal, the DEVICE sets the preset channel after passing edit delay time. Refer to “20•61 : FULL EE ON”.

For the timing, refer to APPENDIX-1.

The items of the setup menu are different from the model.

Model	Item of setup menu
DSR-80/80P, DSR-85/85P	A1 EDIT CH A2 EDIT CH
DSR-2000/2000P DSR-2000A/2000AP	311 : EDIT REPLACE 1 312 : EDIT REPLACE 2 313 : EDIT REPLACE 3 314 : EDIT REPLACE 4

44•31 : PREROLL TIME PRESET

This command is used to preset the preroll time, which has given by the DATA-1 through DATA-4, to the DEVICE.

For the data format, refer to “24•31 : CUE UP WITH DATA”.

Example) Preroll Time=5 sec.

DATA-1	DATA-2	DATA-3	DATA-4
00	05	00	00

41•32 : TAPE/AUTO SELECT

The TAPE/EE mode is selected by the value of the DATA-1.

[DATA-1]

00 : AUTO

01 : TAPE

FF : Depends on the DEVICE.

41•36 : TIMER MODE SELECT

This command is used to select the TIMER system used in the AUTO mode by the value of DATA-1. This is used for the IN ENTRY, OUT ENTRY, IN PRESET, OUT PRESET, PRE-ROLL and CUE UP WITH DATA, etc.

[DATA-1]

00 : TIME CODE

01 : TIMER-1

02 : TIMER-2

FF : Depends on the DEVICE.

41•37 : INPUT CHECK

When DATA-1 is set to "01", VIDEO and all AUDIO Channels are set to Forced EE mode.

When DATA-1 is set to "00", the Forced EE modes of VIDEO and all AUDIO channels are released.

41•3D : PREREAD MODE SELECT

This command is used to select the PREREAD editing in accordance with the contents of the DATA-1.

[DATA-1]

00 : DISABLE

Invalidates the PREREAD editing mode.

01 : ENABLE

Validates the PREREAD editing mode.

FF : Depends on the DEVICE.

43•3F : Δ t REC/PLAY PRESET

This command is used to preset the Δ t REC/PLAY mode in accordance with the contents of DATA.

This is used to switch X1 mode or X4 mode of DSR-85/85P.

When a device receives this command, it starts preparing Δ t REC/PLAY. When the preparation is complete, it sets the status of Δ t REC/PLAY READY (7X•20 : STATUS DATA / DATA No. A bit-3).

[DATA-1]

BIT-7	BIT-6	BIT-5	BIT-4	BIT-3	BIT-2	BIT-1	BIT-0
					VARIABLE REC/PLAY		

1 : ON 0 : OFF

[DATA-2, 3]

It specifies the speed during the Δ t REC/PLAY mode.

For the data format, refer to “2X•12 : VAR FWD”. DSR-85/85P enters X4 mode when (DATA-2 > 40h), and enters X1 mode when (DATA-2 ≤ 40h).

When a device receives the following command in the Δ t REC/PLAY PRESET mode, the DEVICE goes into the Δ t REC/PLAY mode and operates at the speed which is specified by the command.

- 20•01 : PLAY
- 20•02 : REC
- 20•65 : EDIT ON
- 24•34 : SYNC PLAY
- 24•32 : SYNC POINT PREROLL

40•40 : AUTO MODE OFF

40•41 : AUTO MODE ON

This command is used to switch ON/OFF the AUTO mode of the DEVICE.

When receiving this command, this command does not have influence on the operation of the DEVICE.

40•44 : AUDIO SPLIT OFF

44•45 : AUDIO SPLIT ON

This command is used to switch ON/OFF the AUDIO SPLIT MODE of the DEVICE.

When receiving this command, this command does not have influence on the operation of the DEVICE.

40•46 : VARIABLE MEMORY OFF

40•47 : VARIABLE MEMORY ON

This command is used to switch ON/OFF the VARIABLE MEMORY MODE of the DEVICE.

42•50 : DA INPUT SELECT

This command is used to select the input signal source of the audio channels according to the contents of DATA-1 and DATA-2.

[DATA-1/DATA-2]

BIT-7	BIT-6	BIT-5	BIT-4	BIT-3	BIT-2	BIT-1	BIT-0
				DA4	DA3	DA2	DA1

The table below shows the input signal sources for the audio channels.

DATA-1 BIT-X	DATA-2 BIT-X	Input Signal
0	0	DIGITAL AUDIO (AES/EBU)
0	1	ANALOG AUDIO
1	0	NO CHANGE

4X•54 : EXTENDED DA INPUT SELECT

This command is used to select the input audio source according to the value of DATA-1 and DATA-2.

DATA-1		DATA-2	
CH-2	CH-1	CH-4	CH-3
MSD	LSD	MSD	LSD

- 4BIT DATA 0 : ANALOG
 1 : AES/EBU
 2 : SDI
 4 : SDTI
 5 : i.LINK
 E : INTERNAL SG
 F : NO CHANGE

Example) In the case of “42•54•22•00”
 CH-1 & CH-2 : SDI
 CH-3 & CH-4 : ANALOG

41•58 : DA SAMPLING FREQ PRESET

A DEVICE selects the digital audio sampling frequency in accordance with the contents of DATA-1.

[DATA-1]

- 01 : 48.0 kHz
 03 : 32.0 kHz

41•60 : VITC BYPASS

This command is used to select the VITC to be recorded in accordance with the contents of the DATA-1.

[DATA-1]

00 : Records the data of the built-in TCG on the line that is specified in the menu or others.

01 : Records the input video signal as it is.

FF : Depends on the DEVICE.

42•61 : TCG MODE SELECT

This command is used to preset the internal TC generator according to the value of DATA-1 and DATA-2.

[DATA-1]

00 : Time data can be set. Time data is always run.

01 : Time data can be set. Time data is run at recording.

02 : Regenerate the time code by using the playback LTC signal.

03 : The playback VITC signal is regenerated.

04 : Regenerate the time code by using the external LTC signal.

05 : The VITC signal that is read from the input video signal is regenerated.

FE : NO CHANGE

FF : Depends on the DEVICE.

42•70 : VIDEO INPUT SELECT

This command is used for selecting the input video source according to the value of DATA-1 and DATA-2.

[DATA-1]

BIT-7	BIT-6	BIT-5	BIT-4	BIT-3	BIT-2	BIT-1	BIT-0
INTERNAL SG			i.LINK	SDTI		SDI	ANALOG

[DATA-2]

BIT-7	BIT-6	BIT-5	BIT-4	BIT-3	BIT-2	BIT-1	BIT-0
			S (Y/C)		G/R/B	V/PB/PR	COMPOSITE

DATA-1	DATA-2	Input video source
01	01	ANALOG COMPOSITE
01	02	ANALOG COMPONENT (Y-R, B)
01	04	G/R/B
01	10	S (Y/C)
02	02	SDI
08	02	SDTI
10	02	i.LINK
80	XX	Built-in signal generator

41•9E : SUPERIMPOSE

This command is used to control the SUPERIMPOSE mode of the DEVICE according to the value of DATA-1

[DATA-1]

- 00 : SUPERIMPOSE OFF
- 01 : SUPERIMPOSE ON
- FF : Depends on the DEVICE.

4X•AE : AUDIO MONITOR CHANNEL SELECT

This command is used to select either the right and left of the audio channel to be monitored every L/R.

DATA-3: Selects the left channel of the main channel to be monitored.

BIT-7	BIT-6	BIT-5	BIT-4	BIT-3	BIT-2	BIT-1	BIT-0
*	*	*	*	CH-4	CH-3	CH-2	CH-1

* : RESERVED

DATA-4: Selects the right channel of the main channel to be monitored.

BIT-7	BIT-6	BIT-5	BIT-4	BIT-3	BIT-2	BIT-1	BIT-0
*	*	*	*	CH-4	CH-3	CH-2	CH-1

* : RESERVED

Both the right and left channels can select multiple channels at the same time respectively.

40•C0 : TIMELINE STOP

This command is used to stop the TIMELINE (internal clock) of a DEVICE.

40•C1 : TIMELINE RUN

This command is used to start the TIMELINE (internal clock) of a DEVICE. For the timing, refer to APPENDIX-3.

44•C3 : TIMELINE PRESET

This command is used to preset the time data on the TIMELINE (internal clock) of a device. The preset can be executed only when the TIMELINE is stopped.

For the data format, refer to “24•31: CUE UP WITH DATA”.

Selection of either DF or NDF of the TIMELINE is performed in accordance with bit-6 of DATA-1 as shown in the following table.

DATA-1 BIT6	DF/NDF
0	NDF
1	DF

For the timing, refer to APPENDIX-3.

4X•C4 : DEFINE EVENT

This command is used to define the TIMELINE even for a DEVICE.

An event executes the command (DATA-6 ~) in accordance with the specified conditions (DATA-1 to DATA-5), and is deleted. If the event is not executed correctly, the bits corresponding to the ABORT bit (DATA No. 9, bit-7) of STATUS and to the “7X•C8 : UNSUCCESSFUL EVENT” command, are set.

Processing such as edit delay, etc. during editing is performed in the device side. The event is not executed when the TIMELINE is not running, or while CUE UP is executing.

A number is attached to events in the order of transmission (receive) of the “4X•C4 : DEFINE EVENT” command. Both the controller and device control the event numbers with a 1:1 correspondence. The number is consecutively given in the range from 0001h to FFFFh totaling 65535 values. The number increments unless All Clear (DATA-1, 2 = 00h) is performed by the “42•C5 : CLEAR EVENT” command. When the event number exceeds FFFFh, it returns to 0000h. Its contents are ignored even though the “4X•C4 : DEFINE EVENT” command is executed. The event number remains at 0000h. However, the already defined events are executed correctly.

When the remaining capacity of the event buffer in which events are stored becomes 0000h, the contents are ignored when the “4X•C4 : DEFINE EVENT” command is executed and the event numbers are not updated.

DSR series VTR has the capacity of 7 events as a buffer.

When the selected tape time is specified as the trigger source, the events are executed in the order of event numbers. On the contrary, when the timeline is specified as the trigger source, the events are sorted in the order of trigger time, and executed.

[DATA-1]

bit-7

Event processing after execution is specified.

0 : Event is deleted after execution.

1 : Event is stored without deletion after execution so that it can be re-executed.

Re-execution is initiated when the timeline has passed 24 hours or when the timeline agrees with the trigger time as the timeline is re-started, etc. Deletion of the event is performed by the “42•C5 : CLEAR EVENT” command.

bit-6

This specifies the source (trigger source) which generates the trigger timing to execute an event.

0 : Timeline is selected.

1 : Selected tape time is selected.

[DATA-2 to DATA-5]

The timing (trigger time) which triggers execution of an event is specified by the time data. For the data format, refer to “24•31 : CUE UP WITH DATA”.

[DATA-6 ~]

This specifies the command to be executed. The commands which can be specified are the “0X•XX”, “2X•XX”, “4X•XX” and “8X•XX” commands except “00•11” and “0X•FX”.

Example) When executing the PLAY command at 0 hour.

47 C4 00 00 00 00 00 20 01 2C
DEFINE EVENT Timeline 0 hour PLAY Checksum

42•C5 : CLEAR EVENT

This command is used to delete the event which is defined by the “4X•C4: DEFINE EVENT” command.

[DATA-1, DATA-2]

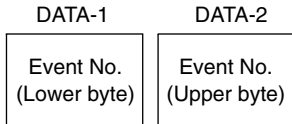

0000h : Deletes all events. (All clear) The event number returns to 0001h and the EVENT buffer and the unsuccessful EVENT buffer are initialized.

0001h to FFFFh : Specifies the event number of the event to be deleted.

The event numbers to be deleted are specified by DATA-1 and DATA-2. When events are deleted, the subsequent events will not be used to fill the blanked events, but the blanked events are left blank.

41•CB : BREAK

The processing which is equivalent to the “20•00 : STOP” command is executed and the timeline is stopped.

[DATA-1]

00h : The processing which is equivalent to the “20•00 : STOP” command is executed immediately and the timeline is stopped.

61•0A : TC GEN DATA SENSE

This command is used to request the TIME CODE data that the DEVICE is generating, and the DEVICE will make a response according to the contents of the DATA-1.

[DATA-1]

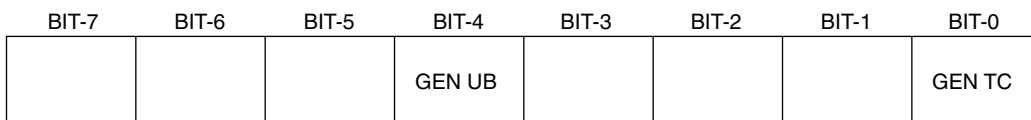

DATA-1=01 : Request for GEN TC “74•08 : GEN TIME DATA”

DATA-1=10 : Request for GEN UB “74•09 : GEN UB DATA”

DATA-1=11 : Request for GEN TC & UB “78•08 : GEN TC & UB DATA”

74•08 : GEN TC DATA

When the DEVICE receives the “61•0A : TC GEN DATA SENSE” command and its DATA-1 is “01”, the TC TIME data generated by the DEVICE will be added to the DATA-1 through DATA-4 of the “74•08 : GEN TIME DATA” command.

For the data format, refer to “24•31 : CUE UP WITH DATA”.

74•09 : GEN UB DATA

When the DEVICE receives the “61•0A : TC GEN DATA SENSE” command and its DATA-1 is “10”, the TC UB data generated by the DEVICE will be added to the DATA-1 through DATA-4 of the “74•09 : GEN UB DATA” command.

For the data format, refer to “4X•05 : USER’S BIT PRESET”.

78•08 : GEN TC & UB DATA

When the DEVICE receives the “61•0A : TC GEN DATA SENSE” command, if the DATA-1 is “11”, the TIME DATA will be added to the DATA-1 through DATA-4 of the “74•08 : GEN TIME DATA” command and the user bit data will be added to the DATA-5 to DATA-8. For the data format, refer to “24•31 : CUE UP WITH DATA” and “4X•05 : USER’S BIT PRESET”.

61•0C : CURRENT TIME SENSE

This command is used for requesting the TIME DATA or USER BIT, and the DEVICE will make a response according to the contents of DATA-1.

When the accurate TIME DATA is requested in the normal playback mode, the following condition must be satisfied.

- Select external reference mode.
- CURRENT TIME SENSE command and its return must be completed within the field-2.

[DATA-1]

The response command according to the request command is as follows.

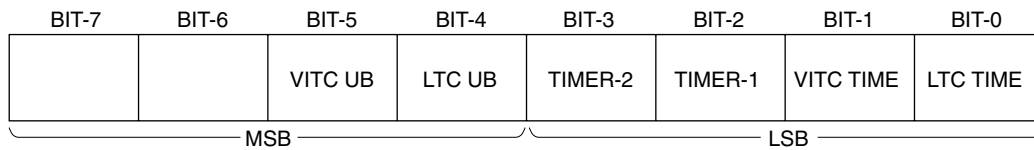

Request DATA-1	01	02	03	04	08	10	20	30	11*3	22*3	33*3
74•00: TIMER-1 DATA				○							
74•01: TIMER-2 DATA					○						
74•04: LTC TIME DATA	○		○								
78•04: LTC TIME & UB DATA									○		○
74•05: LTC U-BIT DATA						○		○			
74•06: VITC TIME DATA		○*1	○*2								
78•06: VITC TIME & UB DATA										○*1	○*2
74•07: VITC U-BIT DATA							○*1	○*2			
74•14: LTC INTERPOLATED TIME DATA	○		○								
78•14: LTC INTERPOLATED TIME & UB DATA									○		○
74•16: VITC HOLD TIME DATA		○*1	○*2								
78•16: VITC HOLD TIME & UB DATA										○*1	○*2

Note :

- *1 : The DSR-60/60P/70/70P/80/80P/85/85P returns the “70•0D: REQUEST TIME DATA MISSING because the VITC READER is not built.
- *2 : The DSR-60/60P/70/70P/80/80P/85/85P does not return the VITC DATA because the READER is not built. (LTC DATA only)
- *3 : When the request command is “DATA-1 = 11, 22, 33, the TIME DATA is returned with DATA-1 through DATA-4 and the USER BIT DATA is returned with DATA-5 through DATA-8.

74•00 : TIMER-1 DATA

When the DEVICE is required the TIMER-1 data by the “61•0C : CURRENT TIME SENSE” command, the TIMER-1 data (COUNTER) will be added to the DATA-1 through DATA-4.

At that time, the DF/NDF mode of TIMER-1 is set to the BIT-6 of DATA-1.

For the data format, refer to “24•31 : CUE UP WITH DATA”.

74•01 : TIMER-2 DATA

When the DEVICE is required the TIMER-2 DATA by the “61•0C : CURRENT TIME SENSE” command, the TIMER-2 DATA (UNRESETTABLE COUNTER) will be added to the DATA-1 through DATA-4.

At that time, the DF/NDF mode of TIMER-2 is set to the BIT-6 of DATA-1.

For the data format, refer to “24•31 : CUE UP WITH DATA”.

74•04 : LTC TIME DATA

When the DEVICE is required the LTC TIME DATA by the “61•0C : CURRENT TIMER SENSE” command, the LTC TIME DATA will be added to the DATA-1 through DATA-4.

For the data format, refer to “24•31 : CUE UP WITH DATA”.

78•04 : LTC TIME & UB DATA

When the DEVICE is required the LTC TIME DATA and USER’S BIT DATA by the “61•0C : CURRENT TIME SENSE” command, the LTC TIME DATA will be added to the DATA-1 through DATA-4 and the LTC USER’S BIT DATA will be added to the DATA-5 through DATA-8.

For the data format, refer to “24•31 : CUE UP WITH DATA” and “4X•05 : USER’S BIT PRESET”.

74•05 : LTC UB DATA

The DEVICE is required the LTC USER’S BIT DATA by the “61•0C : CURRENT TIMER SENSE” command, the LTC USER’S BIT DATA will be added to the DATA-1 through DATA-4.

For the data format, refer to “4X•05 : USER’S BIT PRESET”.

74•06 : VITC TIME DATA

The DEVICE is required the VITC TIME DATA by the “61•0C : CURRENT TIME SENSE” command, the VITC TIME DATA will be added to the DATA-1 through DATA-4.

For the data format, refer to “24•31 : CUE UP WITH DATA”.

78•06 : VITC TIME & UB DATA

The DEVICE is required the VITC TIME DATA and the USER’S BIT DATA by the “61•0C : CURRENT TIME SENSE” command, the VITC TIME DATA will be added to the DATA-1 through DATA-4 and the USER’S BIT DATA will be added to the DATA-5 through DATA-8.

For the data format, refer to “24•31 : CUE UP WITH DATA” and “44•05 : U-BIT PRESET”.

74•07 : VITC UB DATA

The DEVICE is required the VITC USER’S BIT DATA by the “61•0C : CURRENT TIME SENSE” command, the VITC USER’S BIT DATA will be added to the DATA-1 through DATA-4.

For the data format, refer to “44•05 : U-BIT PRESET”.

74•14 : LTC INTERPOLATED TIME DATA

When the DEVICE is required the LTC TIME DATA by the “61•0C : CURRENT TIME SENSE” command and it interpolates with CTL or it had not read exactly, the LTC TIME DATA will be added to the DATA-1 through DATA-4.

For the data format, refer to “24•31 : CUE UP WITH DATA”.

78•14 : LTC INTERPOLATED TIME & UB DATA

The DEVICE is required the LTC TIME DATA and USER'S BIT DATA by the "61•0C : CURRENT TIME SENSE" command and it interpolates with CTL or it is not read exactly, the LTC TIME DATA will be added to the DATA-1 through DATA-4 and the LTC USER'S BIT DATA will be added to the DATA-5 through DATA-8.

For the data format, refer to "24•31 : CUE UP WITH DATA" and "4X•05 : USER'S BIT PRESET".

74•16 : VITC HOLD TIME DATA

The DEVICE is required the VITC TIME DATA by the "61•0C : CURRENT TIME SENSE" command and they had not been read, the VITC TIME DATA will be added to the DATA-1 through DATA-4.

For the data format, refer to "24•31 : CUE UP WITH DATA".

78•16 : VITC HOLD TIME & UB DATA

The DEVICE is required the VITC TIME DATA and the USER'S BIT DATA by the "61•0C : CURRENT TIME SENSE" command and they had not been read, the VITC TIME DATA will be added to the DATA-1 through DATA-4.

For the data format, refer to "24•31 : CUE UP WITH DATA" and "44•05 : U-BIT PRESET".

70•0D : REQUEST TIME DATA MISSING

The DEVICE is required non-existent data by the "61•0C : CURRENT TIME SENSE" command, the DEVICE returns this command to the CONTROLLER.

60•10 : IN DATA SENSE

60•11 : OUT DATA SENSE

60•12 : A IN DATA SENSE

60•13 : A OUT DATA SENSE

These commands are used to request the IN/OUT DATA and the AUDIO IN/OUT DATA.

For the data format, refer to "24•31 : CUE UP WITH DATA".

Request Command	Response Command
IN DATA SENSE	"74•10 : IN DATA"
OUT DATA SENSE	"74•11 : OUT DATA"
A IN DATA SENSE	"74•12 : A IN DATA"
A OUT DATA SENSE	"74•13 : A OUT DATA"

74•10 : IN DATA

When the DEVICE receives the "60•10 : IN DATA SENSE" command, the IN point will be added to the DATA-1 through DATA-4 of the "74•10 : IN DATA".

For the data format, refer to "24•31 : CUE UP WITH DATA".

74•11 : OUT DATA

When the DEVICE receives the "60•11 : OUT DATA SENSE" command, the OUT point will be added to the DATA-1 through DATA-4 of the "74•11 : OUT DATA".

For the data format, refer to "24•31 : CUE UP WITH DATA".

74•12 : A IN DATA

When the DEVICE receives the "60•12 : A IN DATA SENSE" command, the AUDIO IN point will be added to the DATA-1 through DATA-4 of the "74•12 : A IN DATA".

For the data format, refer to "24•31 : CUE UP WITH DATA".

74•13 : A OUT DATA

When the DEVICE receives the “60•13 : A OUT DATA SENSE” command, the AUDIO OUT point will be added to the DATA-1 through DATA-4 of the “74•13 : A OUT DATA”.

For the data format, refer to “24•31 : CUE UP WITH DATA”.

60•20 : STATUS SENSE

This command is used for requesting the status of the DEVICE. The contents of the “7X•20 : STATUS DATA” to be sent back are specified by the DATA-1 that is added to the command.

[DATA-1]

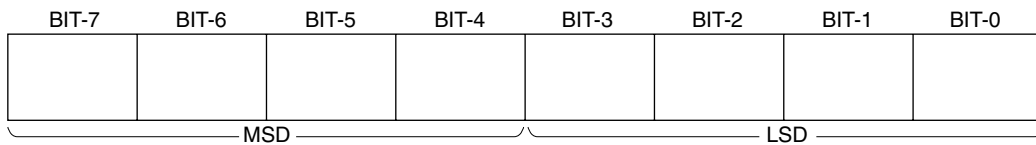

MSD (BIT-7 to 4) : Indicates the initial Data No. of the “7X•20 : STATUS DATA” to be sent back.

LSD (BIT-3 to 0) : Indicates the number of data bytes in “7X•20 : STATUS DATA” to be sent back.

Example) When the DATA-1 of the “60•20 : STATUS SENSE” command is 2A.

The DEVICE will send back ten bytes from the DATA No.2, i. e. DATA No.2 to DATA No.B, of the “7X•20 : STATUS DATA”.

7X•20 : STATUS DATA

This return command is returned in response to the “60•20 : STATUS SENSE” command from the DEVICE. The DEVICE returns the following data in accordance with the request.

STATUS DATA

DATA No.	BIT7	BIT6	BIT5	BIT 4	BIT3	BIT2	BIT1	BIT0
0			CASSETTE OUT	REF VD MISSING		HARD ERROR		LOCAL
1	STANDBY ON	TENSION RELEASE	STOP	EJECT	REW	F.FWD	REC	PLAY
2	SERVO LOCK	TSO MODE	SHUTTLE	JOG	VAR	REV/FWD	STILL	CUE UP COMPLETE
3	AUTO MODE				AUDIO OUT	AUDIO IN	OUT	IN
4	SELECT EE ON	FULL EE ON		EDIT	REVIEW	AUTO EDIT	PREVIEW	PREROLL OR CUE UP
5		INSERT	ASSEMBLE	VIDEO		TIME CODE	AUDIO CH-2	AUDIO CH-1
6								
7	VARIABLE MEMORY	VAR MEMORY ACTIVE	AUDIO SPLIT					IN/OUT STATUS
8		LOST LOCK		END OF TAPE				REC INHIBIT
9	FUNCTION ABORT							
A			Δt REC/PLAY EXECUTE		Δt READY	VAR REC/PLAY		
B								
C					DA4	DA3	DA2	DA1
D								
E								
F								

DATA No.0

DATA No.0/BIT-5 : CASSETTE OUT

BIT-5 will be set to “1” when there is no cassette threading on the DEVICE.

DATA No.0/BIT-4 : REFERENCE VIDEO MISSING

BIT-4 will be set to “1” when the REFERENCE VIDEO is not detected on the REF VIDEO IN connector panel.

DATA No.0/BIT-2 : HARD ERROR

BIT-2 will be set to “1” when the following troubles (the tape is sticking to the drum, the tape is slackening and so on).

For details, refer to the maintenance manual ERROR MESSAGE (SELF DIAGNOSTICS).

DATA No.0/BIT-0 : LOCAL

BIT-0 will be set to “1” when the REMOTE/LOCAL switch on the front panel is set to “LOCAL”.

DATA No.1**DATA No.1/BIT-7 : STANDBY**

BIT-7 will be set to “1” when the DEVICE is the STANDBY ON mode.

DATA No.1/BIT-6 : TENSION RELEASE

BIT-6 will be set to “1” when the DEVICE is the TENSION RELEASE mode.

DATA No.1/BIT-5 : STOP

BIT-5 will be set to “1” when the DEVICE receives the “20•00 : STOP” command and goes into the STOP mode.

DATA No.1/BIT-4 : EJECT

BIT-4 will be set to “1” when the DEVICE receives the “20•0F : EJECT” command and goes into the EJECT mode.

DATA No.1/BIT-3 : REW

BIT-3 will be set to “1” when the DEVICE receives the “20•20 : REWIND” command and goes into the REWIND mode.

DATA No.1/BIT-2 : F.FWD

BIT-2 will be set to “1” when the DEVICE receives the “20•10 : FAST FWD” command and goes into the FAST FORWARD mode.

DATA No.1/BIT-1 : REC

BIT-1 will be set to “1” when the DEVICE receives the “20•02 : REC” command and goes into the REC mode.

BIT-1 will be also set to “1” when “DATA No.4/BIT-4 EDIT” is set to “1”.

DATA No.1/BIT-0 : PLAY

BIT-0 will be set to “1” when the DEVICE receives the “20•01 : PLAY”, “20•02 : REC” or “20•65 : EDIT ON” command and goes into the PLAY, REC or EDIT mode.

DATA No.2**DATA No.2/BIT-7 : SERVO LOCK**

BIT-7 will be set to “1” when the DEVICE is in the condition that the drum and the capstan servos are locked in the PLAY mode.

DATA No.2/BIT-6 : TSO MODE

BIT-6 will be set to “1” when the DEVICE is in the CAPSTAN OVERRIDE mode.

DATA No.2/BIT-5 : SHUTTLE

BIT-5 will be set to “1” when the DEVICE receives the “2X•13 : SHUTTLE FWD” or “2X•23 : SHUTTLE REV”, and goes into the SHUTTLE mode.

DATA No.2/BIT-4 : JOG

BIT-4 will be set to “1” when the DEVICE receives the “2X•11 : JOG FWD” or “2X•21 : JOG REV”, command and goes into the JOG mode.

DATA No.2/BIT-3 : VAR

BIT-3 will be set to “1” when the DEVICE is receives “2X•12 : VAR FWD” or “2X•22 : VAR REV”, command and goes into the VAR mode.

DATA No.2/BIT-2 : TAPE DIRECTION

BIT-2 shows the tape direction defined in the DEVICE.

0 = FWD

1 = REV

DATA No.2/BIT-1 : STILL

BIT-1 will be set to “1” when the DEVICE is STOP mode or STILL mode of SHUTTLE/ JOG/VAR.

DATA No.2/BIT-0 : CUE UP COMPLETE

BIT-0 will be set to “1” when the DEVICE receives “20•30 : PREROLL” and “24•31 : CUE UP WITH DATA” commands and then cue-up operation is completed successfully.

DATA No.3**DATA No.3/BIT-7 : AUTO MODE**

BIT-7 will be set to “1” when the DEVICE receives the “40•41 : AUTO MODE ON” command.

DATA No.3/BIT-3 : AUDIO OUT**DATA No.3/BIT-2 : AUDIO IN****DATA No.3/BIT-1 : OUT****DATA No.3/BIT-0 : IN**

When the DEVICE receives ENTRY, PRESET and RECALL commands of each editing point (IN, OUT, AUDIO IN or AUDIO OUT), the corresponded bit will be set to “1”, and TIMER-1 or TIME CODE data is memorized.

DATA No.4**DATA No.4/BIT-7 : SELECT EE ON**

BIT-7 will be set to “1” when the DEVICE receives the “4X•30 : EDIT PRESET” command, and furthermore, receives the “20•63” : SELECT EE ON” command.

DATA No.4/BIT-6 : FULL EE ON

BIT-6 will be set to “1” when the DEVICE receives the “20•61 : FULL EE ON” command.

DATA No.4/BIT-4 : EDIT

BIT-4 will be set to “1” when the DEVICE is in the EDIT mode, and at the same time, the “DATA No.1/BIT-1 : REC” is also set to “1”.

DATA No.4/BIT-3 : REVIEW

BIT-3 will be set to “1” when the DEVICE is in the REVIEW mode.

DATA No.4/BIT-2 : AUTO EDIT

BIT-2 will be set to “1” when the DEVICE is in the AUTO EDIT mode.

DATA No.4/BIT-1 : PREVIEW

BIT-1 will be set to “1” when the DEVICE is in the PREVIEW mode.

DATA No.4/BIT-0 : PREROLL OR CUE UP

BIT-0 will be set to “1” when the DEVICE receives the “20•30 : PREROLL” and “24•31 : CUE UP WITH DATA” commands, and goes into the PREROLL and CUE-UP mode, and BIT-0 will be also set to “1” when the PREROLL is performed in the AUTO EDIT or PREVIEW mode.

DATA No.5**DATA No.5/BIT-6 : INSERT****DATA No.5/BIT-5 : ASSEMBLE****DATA No.5/BIT-4 : VIDEO****DATA No.5/BIT-2 : TIME CODE (LTC)****DATA No.5/BIT-1 : A2 (AUDIO CH-2)****DATA No.5/BIT-0 : A1 (AUDIO CH-1)**

When the DEVICE receives the “4X•30 : EDIT PRESET” commands, the corresponding bit of DATA No.5 will be set to “1” according to the state of the DATA-1 of the EDIT PRESET command.

Refer to “4X•30 : EDIT PRESET”.

DATA No.7**DATA No.7/BIT-7 : VAR MEMORY MODE**

BIT-7 will be set to “1” when the DEVICE receives the “40•47: VAR MEN ON” command, and goes into the VARIABLE MEMORY mode.

DATA No.7/BIT-6 : VAR MEMORY ACTIVE

BIT-6 will be set to “1” when the DEVICE goes into the VARIABLE MEMORY mode by the “40•47: VAR MEN ON” command and the information is stored in the VAR MEMORY.

DATA No.7/BIT-5 : AUDIO SPLIT

BIT-5 will be set to “1” when the DEVICE receives the “40•45 : AUDIO SPLIT ON” command, and goes into the AUDIO SPLIT mode.

DATA No.7/BIT-0 : IN-OUT STATUS

BIT-0 will be set to “1” when the DEVICE is in the PREVIEW or AUTO EDIT mode and the tape is running between the IN point and OUT point.

DATA No.8

DATA No.8/BIT-6 : LOST LOCK

BIT-6 will be set to "1" when the capstan or drum servo is locked over 10 second, and then the servo is unlocked in the PLAY, REC or EDIT mode.

When the DEVICE receives the "40•2D : LOST LOCK RESET" command, BIT-6 will be reset.

DATA No.8/BIT-4 : END OF TAPE

BIT-4 will be set to "1" when the DEVICE detects BEGIN or END of the cassette tape.

DATA No.8/BIT-0 : REC INHIBIT

BIT-0 will be set to "1" when the REC INHIBIT plug on the cassette is set.

For DSR-60/60P, this bit will always be set to "1".

DATA No.9

DATA No.9/BIT-7 : FUNCTION ABORT

BIT-7 will be set to "1" when the event which is defined by the "4X•C4 : DEFINE EVENT" command, is not executed normally.

DATA No.10

DATA No.10/BIT-5 : Δt REC/PLAY EXECUTE

BIT-5 will be set to "1" when the device goes into the Δt REC/PLAY mode.

DATA No.10/BIT-3 : Δt READY

BIT-3 will be set to "1" when the device is in the Δt REC/PLAY PRESET mode and ready to go into the Δt REC/PLAY mode.

DATA No.10/BIT-2 : VARIABLE REC/PLAY

This bit is set to "1" when the DEVICE receives the "43•3F : Δt REC/PLAY PRESET" command and goes into the Δt REC/PLAY PRESET mode.

DATA No.12

DATA No.12/BIT-3 : DA4

DATA No.12/BIT-2 : DA3

DATA No.12/BIT-1 : DA2

DATA No.12/BIT-0 : DA1

The respective bits will be set to "1" in accordance with the contents of the data which has been added to the command, when the DEVICE receives the "4X•30 : EDIT PRESET" command.

Refer to "4X•30 : EDIT PRESET".

60•2E : COMMAND SPEED SENSE

This command is used to request the TAPE SPEED command in which the DEVICE is operating. When the DEVICE receives this command, it returns the “71•2E : COMMAND SPEED DATA” command.

71•2E : COMMAND SPEED DATA

This return command is returned in response to the “60•2E : CMD SPEED SENSE” command from the CONTROLLER. The DEVICE returns its own tape speed data in accordance with the request.

For the data format, refer to “2X•11 : JOG FWD”.

60•2F : VARIABLE MEMORY SPEED SENSE

This command is used to request the INITIAL SPEED DATA that is stored in the VARIABLE MEMORY mode of the DEVICE.

When the DEVICE receives this command, it returns the “71•2F: VARIABLE MEMORY SPEED DATA” command.

71•2F : VARIABLE MEMORY SPEED DATA

This return command is returned in response to the “60•2F: VARIABLE MEMORY SPEED SENSE” command from the CONTROLLER. The DEVICE returns the command added to the INITIAL SPEED DATA in accordance with the request.

For the data format, refer to “2X•11, 2X•12, 2X•13: JOG, VAR, SHUTTLE FWD” command.

6X•30 : EDIT PRESET SENSE

This command is used to request the EDIT PRESET status of the DEVICE, and the contents of the “7X•30 : EDIT PRESET DATA” command to be sent back are assigned by DATA-1 added to the command.

[DATA-1]

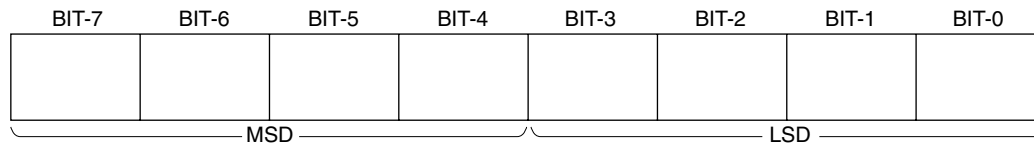

MSD (BIT 7~4) : These indicate the initial data No. of the “7X•30 : EDIT PRESET DATA” command to be sent back.

LSD (BIT 3~0) : These indicate the number of bytes in the data to be sent back from the data in the “7X•30 : EDIT PRESET DATA” command to be sent back.

When the “60•30” is received ; The DEVICE works same as “61•30•01” command.

7X•30 : EDIT PRESET DATA

This return command is returned in response to the “6X•30 : EDIT PRESET SENSE” command from the CONTROLLER. The DEVICE returns the data in accordance with the request.

For the data format, refer to “4X•30 : EDIT PRESET”.

EDIT PRESET STATUS

DATA No.	BIT7	BIT6	BIT5	BIT4	BIT3	BIT2	BIT1	BIT0
0		INSERT	ASSEMBLE	VIDEO		A3 (TC)	A2 (CUE)	A1 (CUE)
1					DA4	DA3	DA2	DA1
2								
3								
4								
5								
6								
7								
8								
9								
A								
B								
C								
D								
E								
F								

60•31 : PREROLL TIME SENSE

This command is used to request the PREROLL TIME setting status of the DEVICE.

When the DEVICE receives this command, it is sent back the “74•31 : PREROLL TIME DATA” with DATA1 to DATA4 that shows the PREROLL TIME setting status.

74•31 : PREROLL TIME DATA

This return command is returned in response to the “60•31 : PREROLL TIME SENSE” command, from the CONTROLLER. The DEVICE returns the PREROLL TIME DATA in accordance with the request.

For the data format, refer to “24•31 : CUE UP WITH DATA”.

60•32 : TAPE/AUTO SENSE

This command is used to request the TAPE/AUTO status of the DEVICE. When the DEVICE receives this command, it returns the “71•32 : TAPE/AUTO STATUS DATA” command. The TAPE/AUTO STATUS with DATA-1 that shows the setting will be sent back.

71•32 : TAPE/AUTO STATUS DATA

This return command is returned in response to the “60•32 : TAPE/AUTO SENSE” command from the CONTROLLER. The DEVICE returns the value of setting in accordance with the request.

For the data format, refer to “41•32 : TAPE/AUTO SELECT”.

60•36 : TIMER MODE SENSE

This command is used to request the TIMER MODE or TIMER 1 or TIME CODE of the DEVICE.

When the DEVICE receives this command, it returns the “71•36 : TIMER MODE DATA” command. The TIMER MODE DATA with DATA-1 that shows the setting will be sent back.

71•36 : TIMER MODE DATA

This return command is returned in response to the “60•36 : TIMER MODE SENSE” command from the CONTROLLER. The DEVICE returns the value of setting in accordance with the request.

[DATA-1]

- 00 : TIME CODE
- 01 : TIMER-1
- 02 : TIMER-2

60•3F : Δ t REC/PLAY PRESET SENSE

This command is used to request the Δ t REC/PLAY PRESET status of the DEVICE. When the DEVICE receives this command, it returns the “73•3F : Δ t REC/PLAY PRESET DATA” command.

73•3F : Δ t REC/PLAY PRESET DATA

This return command is returned in response to the “60•3F : Δ t REC/PLAY PRESET SENSE” command. The DEVICE returns its own Δ t REC/PLAY PRESET status in accordance with the request. For the data format, refer to “43•3F : Δ t REC/PLAY PRESET”.

Example) When DSR-85/85P is in the X4 mode :

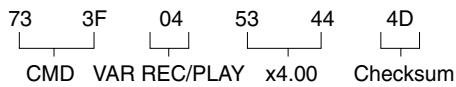

In the case of DSR-80/80P/60/60P :

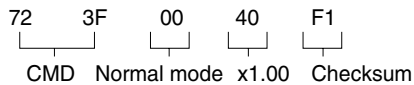

60•50 : DA INPUT SENSE

This command is used to request the audio input signal selection status of the DEVICE. When the DEVICE receives this command, it returns the “71•50 : DA INPUT STATUS” command. The DA INPUT STATUS with DATA-1 that shows the setting will be sent back.

71•50 : DA INPUT STATUS

This return command is returned in response to the “60•50 : DA INPUT SENSE” command from the DEVICE. The DEVICE returns the data that the command is added to the audio input status.

[DATA-1]

BIT-7	BIT-6	BIT-5	BIT-4	BIT-3	BIT-2	BIT-1	BIT-0
				DA4	DA3	DA2	DA1

1 : ANALOG AUDIO INPUT
0 : DIGITAL AUDIO INPUT

6X•54 : EXTENDED DA INPUT SENSE

This command is used to request the digital audio input status.

When the “60•54” is specified, this command requests the input selection status of all digital audio input channels that the machine is equipped with.

For the return data, refer to “7X•54 : EXTENDED DA INPUT STATUS”.

When the “61•54” is specified, this command specifies the groups for every two channels by the BIT-7 to BIT-0 of the DATA-1 as follows.

For the return data, refer to “7X•54 : EXTENDED DA INPUT STATUS”.

[DATA-1]

BIT-7	BIT-6	BIT-5	BIT-4	BIT-3	BIT-2	BIT-1	BIT-0
						CH-3, CH-4	CH-1, CH-2

7X•54 : EXTENDED DA INPUT STATUS

This return command is returned in response to the “6X•54 : EXTENDED DA INPUT SENSE” command from the CONTROLLER. The DEVICE returns the digital audio input status in accordance with the request.

When the “60•54” is received, the status data of all channels (channel 1 through N) will be sent back. Each channel status is composed of 4 bits data as follows.

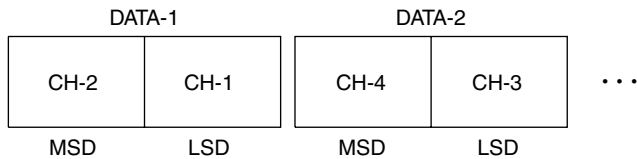

- 4BIT DATA 0 : ANALOG
 1 : AES/EBU
 2 : SDI
 4 : SDTI
 5 : i.LINK
 E : INTERNAL SG
 F : INVALID

When the “61•54” is received, the specified status data corresponding to the bitmap will be sent back from the lower channel number. The data format is same as the return status for “60•54”.

60•58 : DA SAMPLING FREQ SENSE

This command is used to request the sampling frequency of the DEVICE’s digital audio channels. When the DEVICE receives this command, it returns the “71•58 : DA SAMPLING FREQ STAUS” command. The DA SAMPLING FREQ STATUS with DATA-1 that shows the sampling frequency will be sent back.

71•58 : DA SAMPLING FREQ STATUS

This return command is returned in response to the “60•58 : DA SAMPLING FREQ SENSE” command from the CONTROLLER. The DEVICE returns the data that adds the digital audio sampling frequency data.

[RETURN DATA-1]

01 : 48.0 kHz

03 : 32.0 kHz

60•60 : VITC BYPASS SENSE

This command is used to request the VITC to be recorded. When the DEVICE receives this command, it returns the “71•60 : VITC BYPASS STATUS” command. The VITC BYPASS STATUS with DATA-1 that shows the setting will be sent back.

71•60 : VITC BYPASS STATUS

This return command is returned in response to the “60•60 : VITC BYPASS SENSE” command from the CONTROLLER, it returns the VITC information to be recorded with DATA-1.

For the data format, refer to “41•60 : VITC BYPASS” command.

60•61 : TCG MODE SENSE

This command is used to request the TC GENERATOR MODE status of the DEVICE. When the DEVICE receives this command, it returns the “72•61 : TCG MODE” command. The TC GENERATOR MODE STATUS with DATA-1 and DATA-2 that shows the setting will be sent back.

72•61 : TCG MODE

This return command is returned in response to the “60•61 : TCG MODE SENSE” command from the CONTROLLER. The DEVICE returns the data that adds the TC GENERATOR MODE data.

For the data format, refer to “42•61 : TCG MODE SELECT”.

60•70 : VIDEO INPUT SENSE

This command is used to request the video input source.

When the DEVICE receives this command, it returns the “72•70 : VIDEO INPUT STATUS” command. The VIDEO INPUT STATUS with DATA-1 and DATA-2 that shows the setting will be sent back.

72•70 : VIDEO INPUT STATUS

This return command is returned in response to the “60•70 : VIDEO INPUT SENSE” command from the CONTROLLER. The DEVICE returns the video input source.

The connector status is stored in the DATA-1 and the signal status is stored in DATA-2.

[DATA-1]

BIT-7	BIT-6	BIT-5	BIT-4	BIT-3	BIT-2	BIT-1	BIT-0
INTERNAL SG			i.LINK	SDTI		SDI	ANALOG

[DATA-2]

BIT-7	BIT-6	BIT-5	BIT-4	BIT-3	BIT-2	BIT-1	BIT-0
			S (Y/C)		G/B/R	Y/PB/PR	COMPOSITE

60•9E : SUPERIMPOSE SENSE

This command is used to request SUPERIMPOSE STATUS of the DEVICE. When the DEVICE receives this command, it returns the “71•9E : SUPERIMPOSE STATUS” command. The SUPERIMPOSE STATUS with DATA-1 that shows the setting will be sent back.

71•9E : SUPERIMPOSE STATUS

This return command is returned in response to the “60•9E : SUPERIMPOSE SENSE” command from the CONTROLLER. The DEVICE returns the data that the command is added to the SUPERIMPOSE ON/OFF data.

For the data format, refer to “41•9E : SUPERIMPOSE”.

60•AE : AUDIO MONITOR CHANNEL SENSE

This command is used to request the selection channel of the audio monitor. When the DEVICE receives this command, it returns the “74•AE : AUDIO MONITOR CHANNEL STATUS” command. The AUDIO MONITOR CHANNEL STATUS with DATA-1 through DATA-4 that shows the setting will be sent back.

74•AE : AUDIO MONITOR CHANNEL STATUS

The return command is returned in response to the “60•AE : AUDIO MONITOR CHANNEL SENSE” command. The DEVICE returns the current selection.

For the data format, refer to the “44•AE : AUDIO MONITOR CHANNEL SELECT” command.

60•C2 : TIMELINE SOURCE SENSE

This command is used to inquire which source is selected as the source of timeline.

71•C2 : TIMELINE SOURCE

This return command is returned in response to the “60•C2 : TIMELINE SOURCE SENSE” command.

[DATA-1]

00 : Internal Clock (Built-in clock which is synchronized with the reference video signal)

60•C3 : TIMELINE TIME SENSE

This command is used to request the present time value of the TIMELINE.

When the exact time value is required, the TIMELINE TIME SENSE and the RETURN must be completed within the second field while it is synchronized with the reference video signal of the device.

75•C3 : TIMELINE TIME

This return command is returned in response to the “60•C3 : TIMELINE TIME SENSE” command, and returns the following data.

[DATA-1]

This indicates the source of TIMELINE which is selected at present.

00 : Internal Clock (Built-in clock which is synchronized with the reference video signal)

[DATA-2 to DATA-5]

This indicates the present time value of the TIMELINE.

For the data format, refer to “24•31 : CUE UP WITH DATA”.

62•C4 : EVENT DATA SENSE

This command is used to request the contents of the event which is defined by the “4X•C4 : DEFINE EVENT” command.

[DATA-1, DATA-2]

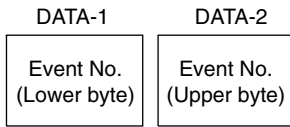

This specifies the event number which is requested by DATA-1 and DATA-2. The event number is a 16-bit data from 0001h to FFFFh, in which 0000h cannot be specified.

7X•C4 : EVENT DATA

This return command is returned in response to the “62•C4 : EVENT DATA SENSE” command from the CONTROLLER. The contents of definition of event are returned. If the specified event has not been defined yet, “70•C4” is returned.

For the data format, refer to “4X•C4 : DEFINE EVENT”.

60•C6 : TIMELINE STATUS SENSE

This command is used to request the various statuses such as the status of the buffer for event definition, execution status of event, etc.

75•C6 : TIMELINE STATUS

This return command is returned in response to the “60•C6 : TIMELINE STATUS SENSE” command.

[DATA-1]

This indicates the execution status of the defined event.

bit-4

0 : No errors are detected during execution of events.

1 : An error occurred in the event which is being executed.

The event in which the error occurred can be determined by the “61•C8 : UNSUCCESSFUL EVENT SENSE” command.

bit-3

0 : Preparation to run the timeline is ready.

1 : Preparation to run the timeline is not ready yet.

bit-1, bit-0

0 0 : Event is not defined yet.

0 1 : Among the already defined events, some events have not been executed yet. Un-executed events can be determined by the “61•C7 : EVENT QUEUE SENSE” command.

1 0 : All of the defined events are executed.

[DATA-2, DATA-3]

The remaining capacity of the event buffer is indicated by the numbers of events. This data consists of a lower byte in which DATA-2 is stored, and an upper byte in which DATA-3 is stored. It indicates the remaining capacity up to the maximum 65535 equivalent events with FFFFh.

[DATA-4, DATA-5]

The event number which will be assigned during next execution of the “4X•C4 : DEFINE EVENT” command is indicated by 16-bit data. The lower byte is assigned to DATA-4 and the upper byte is assigned to DATA-5.

61•C7 : EVENT QUEUE SENSE

This command is used to request which event is waiting for execution among the events that are defined by the “4X•C4 : DEFINE EVENT” command.

[DATA-1]

This specifies which of the events waiting for execution is to be returned.

bit-4

0 : This specifies to start returning from the top of the event buffer.

1 : The next data after the event that is returned in the previous time among the events waiting for execution, is started to be returned.

bit-2 ~ bit-0

This specifies how many events' worth of data are to be returned. A maximum of 7 can be specified.

7X•C7 : EVENT QUEUE

This return command is returned in response to the “61•C7 : EVENT QUEUE SENSE” command.

The events which are waiting for execution are returned in the order of event number.

The maximum number of events which can be returned at once is 7 events. When the specified number of data is less than 1 or when “70•C7” is returned, it indicates that there is no remaining data.

[DATA-1, DATA-2]

This indicates an event number (0001h to FFFFh) which has not been executed yet.

The lower byte is assigned to DATA-1 and the upper byte is assigned to DATA-2.

[DATA-3, DATA-4]

This indicates an event number (0001h to FFFFh) which has not been executed yet. The lower byte is assigned to DATA-3 and the upper byte is assigned to DATA-4.

-
-
-
-

61•C8 : UNSUCCESSFUL EVENT SENSE

This command is used to request information about the event in which an error is detected. The event in which an error is detected is stored in the unsuccessful EVENT buffer as an unsuccessful EVENT. They are stored in the order of error detection.

DSR series VTR has the capacity of 5 events as the unsuccessful EVENT buffer.

[DATA-1]

This specifies which unsuccessful EVENT is to be returned.

bit-4

0 : Return is started from the top of the unsuccessful EVENT buffer.

1 : Return is started from the next data after the unsuccessful EVENT that was returned previously.

bit-2 ~ bit-0

This specifies how many events' worth of data are to be returned. A maximum of 5 can be specified.

7X•C8 : UNSUCCESSFUL EVENT

This return command is returned in response to the “61•C8 : UNSUCCESSFUL EVENT SENSE” command. Data equivalent to one event consists of 3 bytes as described below, and is returned.

The maximum number of events which can be returned at once is 5 events. When the specified number of data is less than 1 or when “70•C8” is returned, it indicates that there is no remaining data. When the data exceeds the capacity of the unsuccessful EVENT buffer, subsequent data will not be stored. The unsuccessful EVENTS are deleted from the buffer using the “42•C5 : CLEAR EVENT” command.

[DATA-1, DATA-2]

This indicates the event number (0001h to FFFFh) of the unsuccessful EVENTS. The lower byte is assigned to DATA-1 and the upper byte is assigned to DATA-2.

[DATA-3]

This indicates the contents of the detected error.

bit-2	bit-1	bit-0	
0	0	1	: The event was executed, but an error is detected.
0	1	0	: The event could not be executed as it has an error.
1	0	0	: The event has not been executed even though the trigger time has elapsed.
			.
			.
			.
			.

7-2. DSR-DR1000/A Disk Command (Ver 1.10 or later)

1. OPEN PLAY & CLOSE

(1) OPEN PLAY

The OPEN PLAY command is used in the DSR-DR1000 to cue up to the specified clip, and to play back the Playlist that is created by the VFL Download or saved by the Clip menu.

The DSR-DR1000 identifies Playlist from Clip by the extension “.dlt” whether the extension “.dlt” is added or not to the end of a filename. If the extension “.dlt” is added, the DSR-DR1000 identifies the file as a Playlist. If it is not added, the DSR-DR1000 identifies that a Clip is specified.

Note that the OPEN PLAY command is invalid in the following cases due to the DSR-DR1000 system configuration.

- When the Disk menu is being opened.
- When the Network menu is being opened.
- When the Clip menu is being opened.
- When the Clip Play is in progress.
- When the Repeat mode is ON.

Command format

Item	Size	Value	Description
DC	1	0xXX	Data Count
CMD1	1	0x16	Command1
CMD2	1	0x00	Command2
DATA1	1	0xXX	PORT ID
DATA2	1	0xXX	OPTION
DATA3	1	0xXX	DRIVE ID
DATA4	n	0xXX..	FILE NAME
DATA5	3	0xXX	CHANNEL BITMAP 1
		0xXX	CHANNEL BITMAP 2
		0xXX	CHANNEL BITMAP 3
DATA6	4	0xXX	START TIME CODE (Frames)
		0xXX	START TIME CODE (Seconds)
		0xXX	START TIME CODE (Minutes)
		0xXX	START TIME CODE (Hours)
DATA7	4	0xXX	DURATION (Frames)
		0xXX	DURATION (Seconds)
		0xXX	DURATION (Minutes)
		0xXX	DURATION (Hours)

PORT ID : It is ignored in the DSR-DR1000.

OPTION : An option is specified by bit.

DRIVE ID : It is fixed to 0x00.

FILE NAME : It specifies a Playlist to be opened or a Clip to be cued up.

CHANNEL BITMAP : It is ignored in the DSR-DR1000.

START TIME CODE : The 4-byte timecode data in BCD format.

DURATION : It is ignored in the DSR-DR1000.

The option that can be specified with the DSR-DR1000 is the START TIME CODE only. Other options are ignored even if they are set. The START TIME CODE can be specified with the FTC only and the FTC indicates the specified Playlist or the position from the top of the Clip.

The statuses at OPEN PLAY in the DSR-DR1000 are shown below.

FILE OPEN STATUS	Value	Description
FILE OPEN MODE	0x00	OPEN PLAY
FILE OPEN STATUS	0x01	NOT OPENED
	0x02	IN PROGRESS
	0x08	OPEN COMPLETE
	0x10	FAIL, FILE NOT FOUND
	0x15	FAIL, ILLEGAL VALUE
	0x1A	FAIL, DRIVE NOT READY
	0x1F	FAIL, OTHER REASONS

Status of the OPEN PLAY command of the DSR-DR1000 is indicated by the EJECT bit (bit-4) of the status data of the VTR command. When the EJECT bit is changed from 1 to 0, it indicates that the OPEN PLAY operation is completed.

DATA No.	BIT7	BIT6	BIT5	BIT4	BIT3	BIT2	BIT1	BIT0
1 ON	STANDBY	TENSION RELEASE	STOP	0 (EJECT)	REW	F.FWD	REC	PLAY

Notes

- If the Stop button on the front panel is pressed, or the DSR-DR1000 has entered either the Disk menu or Network menu or Repeat Function while the Playlist is being opened, the DSR-DR1000 returns to the state that it plays back the default.dlt. (The screen returns to the previous screen before OPEN.)
- The OPEN PLAY command can be used also when it is not in the CLOSE state (i.e., when the EJECT bit is ON). However, you cannot confirm if the OPEN PLAY has terminated or not from the EJECT bit information. (The EJECT bit does not change.)

(2) CLOSE

In the DSR-DR1000, the CLOSE command is used to set the EJECT bit of the Status data of the VTR command, and to move the mode to the Stop mode if the DSR-DR1000 is not in the stop mode before it receives the CLOSE command.

Command format

Item	Size	Value	Description
DC	1	0x01	Data Count
CMD1	1	0x19	Command1
CMD2	1	0x01	Command2
DATA1	1	0x00	FILE HANDLE

Conditions of operation

FILE HANDLE 0x00 only

Status of the CLOSE command of the DSR-DR1000 is indicated by the EJECT bit (bit-4) of the status data of the VTR command. When the EJECT bit is 1, it indicates that the CLOSE operation is completed.

DATA No.	BIT7	BIT6	BIT5	BIT4	BIT3	BIT2	BIT1	BIT0
1 ON	STANDBY	TENSION RELEASE	STOP	1 (EJECT)	REW	F.FWD	REC	PLAY

(3) Sequence of OPEN PLAY and CLOSE

In the DSR-DR1000, since the OPEN PLAY command the CLOSE command are required as a pair, they are described at the same time as follows.

Completion of the OPEN PLAY command the CLOSE command can be checked in the DSR-DR1000, by the EJECT bit (bit-4) of the status data of the VTR command.

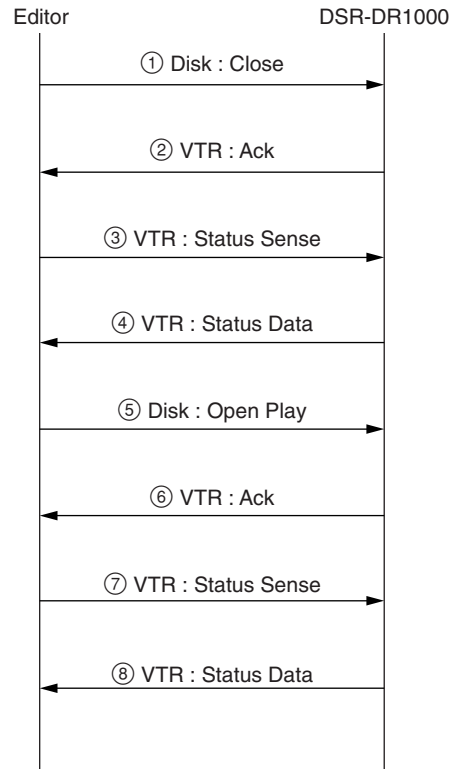

In the DSR-DR1000, a series of the OPEN PLAY command the CLOSE command are expected to be issued and executed as described above as the correct sequence of operation.

At the timing ①, the DSR-DR1000 receives the CLOSE command and performs the CLOSE processing. In order to check that the CLOSE processing is completed, the Status Sense is issued to the DSR-DR1000 at the timing ③ and the status data is returned at the timing ④. If the EJECT bit (bit-4) of the status data is 1, completion of the CLOSE command is confirmed.

DSR-DR1000 receives the OPEN PLAY command at the timing ⑤, and performs the OPEN PLAY processing. In order to check that the OPEN PLAY processing is completed, the Status Sense is issued to the DSR-DR1000 at the timing ⑦ and the status data is returned at the timing ⑧. If the EJECT bit (bit-4) of the status data is 0, completion of the OPEN PLAY command is confirmed.

2. VFL DOWNLOAD DATA

In the DSR-DR1000, all of the VFL DOWNLOAD DATA commands including VFL DOWNLOAD DATA CLEAR command, the VFL DOWNLOAD DATA SET command and the VFL DOWNLOAD WRITE command result in an error when the DSR-DR1000 is in any of the following states due to the DSR-DR1000 system configuration.

- When the Disk menu is being opened.
- When the Network menu is being opened.
- When the Clip menu is being opened.
- When the Repeat mode is ON.

(1) VFL DOWNLOAD CLEAR

In order to perform the VFL DOWNLOAD processing in the DSR-DR1000, the VFL DOWNLOAD DATA CLEAR command, the VFL DOWNLOAD DATA SET command and the VFL DOWNLOAD DATA WRITE command must be issued in the above-described order unless each of these commands does not issue an error. When the DSR-DR1000 receives the VFL DOWNLOAD DATA CLEAR command, it checks inside the DSR-DR1000, that sequence of the VFL DOWNLOAD commands is correct without an error.

Command format

Item	Size	Value	Description
DC	1	0x01	Data Count
CMD1	1	0x10	Command1
CMD2	1	0x43	Command2

Statuses of the VFL DOWNLOAD DATA CLEAR command in the DSR-DR1000 are shown below.

SYSTEM STATUS	Value	Description
Command Status	0x43	VFL DOWNLOAD DATA CLEAR
Execution Status	0x00	COMPLETE
	0x01	IN PROGRESS
	0x02	FAIL

(2) VFL DOWNLOAD DATA SET

In the DSR-DR1000, the VFL DOWNLOAD DATA SET command is used to create the Playlist by specifying the name of the Clip that is stored in the DSR-DR1000.

Command format

Item	Size	Value	Description
DC	1	0xXX	Data Count
CMD1	1	0x10	Command1
CMD2	1	0x41	Command2
DATA1	1	0x0X	OPTION
DATA2	n	0xXX..	VFL NAME
DATA3	n	0xXX..	VFL DATA

OPTION Used to specify TIME CODE only. (FTC and LTC can be set.)

VFL NAME The VFL filename should be either [*.*.dlt] or [*]. Length of a filename is limited up to 20 characters for [*.*.dlt] including [.dlt]. However, there are limitations when using the file as shown below. Refer to the page after next “Limitations of VFL NAME”.

VFL DATA The maximum number of events that can be handled are 200. Refer to the next page and onwards regarding the restrictions on VFL TEXT and the VFL Format.

VFL Format

```
[title_field] [CRLF]
[out_ch] [CRLF]
[in_point] [SP] [out_point] [SP] [drive_id] [SP] [filename] [SP] [av_select] ({SP}[OPTION]{SP}[OPTION]...[OPTION]})[CRLF]
[in_point] [SP] [out_point] [SP] [drive_id] [SP] [filename] [SP] [av_select] ({SP}[OPTION]{SP}[OPTION]...[OPTION]})[CRLF]
.
.
.
[in_point] [SP] [out_point] [SP] [drive_id] [SP] [filename] [SP] [av_select] ({SP}[OPTION]{SP}[OPTION]...[OPTION]})[CRLF]
[out_ch] [CRLF]
[in_point] [SP] [out_point] [SP] [drive_id] [SP] [filename] [SP] [av_select] ({SP}[OPTION]{SP}[OPTION]...[OPTION]})[CRLF]
[in_point] [SP] [out_point] [SP] [drive_id] [SP] [filename] [SP] [av_select] ({SP}[OPTION]{SP}[OPTION]...[OPTION]})[CRLF]
.
.
.
[in_point] [SP] [out_point] [SP] [drive_id] [SP] [filename] [SP] [av_select] ({SP}[OPTION]{SP}[OPTION]...[OPTION]})[CRLF]
.
.
.
[EOF]
```

OPTION may be omitted → Downward compatibility with the current format is maintained.

Contents of OPTION :

```
-Video_***** (***** : hex number) Unity = 0x4000
-Chroma_***** (***** : hex number) Unity = 0x4000
-Hue_***** (***** : hex number) Unity = 0x0000 (2's Compliment)
-Setup_***** (***** : hex number) Unity = 0x0000 (2's Compliment)

-Audio_***** (***** : hex number) Unity = 0x100000
-Fade_* (* : 0 or V or X) Fade effect is applied to the end of specified area.
```

Limitations of VFL TEXT

Limitations of the VFL TEXT that can be used in the DSR-DR1000 are shown below.

- The supported formats of the timecode data are LTC and FTC. (Attribute.dat of each Clip is used to identify LTC.)
- A clip cannot be created during recording (It cannot be opened).
- When out_ch is specified, only the video signal can be used. The other channels are not supported.
- MUTE and FREEZE are not supported as filename of the VFL text.
- VFL in VFL is not supported.
- Extended VFL is not supported.
- With regard to av_select, only [*] is supported.
- With regard to the Drive ID, only 0 is supported.
- Title_field is not used as Data. (Even when there is no title_field, however, the subscript CRLF is required.)
- The minimum Duration that can be registered at 1 Event is 5 Frames.

Limitations of VFL NAME

In the DSR-DR1000, the VFL NAME that creates problem in the system configuration cannot be used as shown below.

- The host system that performs the VFL downloading cannot specify “default.dlt” or “cliplist0.dlt” or “RepeatTmp.dlt” as the VFL NAME. (The filenames from which [.dlt] is deleted from the above-described NAMES cannot also be used.) At the same time, “00XXX” that is used as the name of Clip in the DSR-DR1000 cannot also be specified.
- For the files using [*], up to 16 characters in the range of 20 to 4 can be used because [.dlt] is added later inside the system. ([*] means wild card.) A maximum of seven VFLs can be registered. If any VFL that uses the already registered VFL NAME, the existing VFL will be overwritten when it is downloaded and saved.

STATUS processing

Statuses of the VFL DOWNLOAD DATA SET in the DSR-DR1000 are shown below.

SYSTEM STATUS	Value	Description
Command Status	0x41	VFL DOWNLOAD DATA SET
Execution Status	0x00	COMPLETE
	0x01	IN PROGRESS
	0x02	FAIL
	0x03	FAIL, ILLEGAL DATA
	0x04	FAIL, CURRENT_STATUS ERROR
	0x21	FAIL, FILE IS NOT EXIST
	0x26	FAIL, TIME CODE IS OUT OF RANGE OF THE FILE
	0x28	FAIL, LACK OF RECORD ENTRY

(3) VFL DOWNLOAD DATA WRITE

In the DSR-DR1000, the VFL DOWNLOAD DATA WRITE command is used to register the Playlist that is created on the basis of the VFL NAME and VFL TEXT that are specified by the VFL DOWNLOAD DATA SET command.

Command format

Item	Size	Value	Description
DC	1	0xXX	Data Count
CMD1	1	0x10	Command1
CMD2	1	0x42	Command2
DATA1	1	0xXX	DRIVE ID
DATA2	n	0xXX..	VFL NAME

DRIVE ID 0x00 only

VFL NAME No processing is executed even if it is specified.

Statuses of the VFL DOWNLOAD DATA WRITE command in the DSR-DR1000 are shown below.

SYSTEM STATUS	Value	Description
Command Status	0x42	VFL DOWNLOAD DATA WRITE
Execution Status	0x00	COMPLETE
	0x01	IN PROGRESS
	0x02	FAIL
	0x03	FAIL, NOT REGISTRATION

(4) VFL DOWNLOAD Sequence

In the DSR-DR1000, a series of the commands expected to be issued and executed as described below as the correct sequence of the VFL DOWNLOAD DATA operation.

The time interval between the command outputs must be less than two seconds.

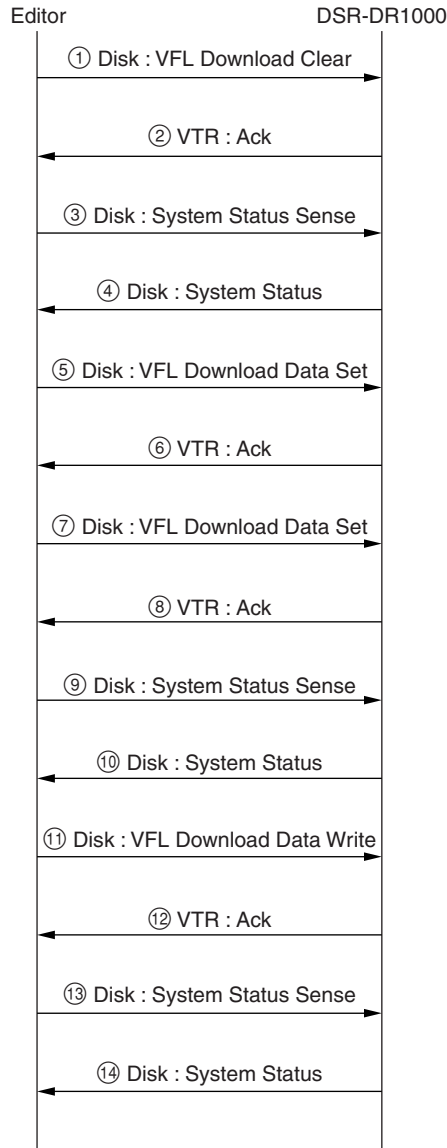

In the DSR-DR1000, the command that will be used to check error related to the VFL DOWNLOAD DATA command becomes the System Status. The identification number of the command is set in the No. 544th CMD status of the System Status Table. Result of execution is reflected on the No. 545th EXEC status of the System Status Table. (Refer to “(6) SYSTEM STATUS” on page 63.)

In the DSR-DR1000, sequence of executing the VFL DOWNLOAD DATA command has the following limitations.

- In order to execute the VFL DOWNLOAD DATA command in the DSR-DR1000, the VFL DOWNLOAD DATA CLEAR command, the VFL DOWNLOAD DATA SET command and the VFL DOWNLOAD DATA WRITE command must be issued in the above-described order. Any other command other than the System Status Sense should not be inserted in between the above-described commands.
- In order to check error in the VFL DOWNLOAD command, the System Status Sense should be used.

The point that requires attention in the above-described sequence of executing the VFL DOWNLOAD DATA command is the steps ⑤ and ⑦ where the VFL DOWNLOAD DATA SET command is repeated twice consecutively. In case if the VFL TEXT command cannot be contained in a single command, top of the command is changed from 0x30 to 0x31 that enables to send the VFL DOWNLOAD DATA SET command continuously. In such a case, the VFL DOWNLOAD DATA SET command processing is completed when the last 0x30 is received and the data is registered in the memory. If top of a command is 0x31, and if the VFL DOWNLOAD DATA SET command continues after that, the system status becomes IN PRO unless the registered data issues and error.

3. DELETE

(1) DELETE

In the DSR-DR1000, “DELETE” means the DELETE (CLIP/Playlist) processing performed by using the ALL DELETE/CLIP DELETE operation commanded by Front Panel (to be abbreviated simply as FP hereafter) and the DELETE (CLIP/Playlist) operation commanded by the Disk command supplied from the CONTROL DEVICE. The “ALL DELETE” operation means to delete laterally all files of the CLIP-related files and Playlist and others, to return the system to the initial status. The “CLIP DELETE” (FP/Disk Com) operation means to remove the targeted CLIP-related files using the default.dlt and Playlist, so that the truncation operation and other operations are executed. If the mode is playback mode, the current position and TC are changed in the “CLIP DELETE” (FP/Disk Com) operation. The “DELETE” command of the Disk command has the two types: one is to delete the CLIP-related files from FP in the same way as CLIP DELETE, while the other type is to delete the Playlist-related files.

Disk Command Delete

<Operation>

- While the DISK MENU/NETWORK MENU/CLIP MENU is in progress, it performs the exclusive OR operation.
- While CLIP playback is in progress or while REC is in progress, it performs the exclusive OR operation.
- When a Playlist is specified, the Playlist and the reference files are deleted.
- When a CLIP is specified, the CLIP-related files and -folders are deleted from the related files such as default.dlt and are updated.
- Upon completion of deletion, the file default.dlt is set to the playback-ready state.
- Upon completion of deletion, the Exec Status of Drive Status will be updated.
- If a Clip before the Current Clip is deleted, the tape is cued up to the same position (same picture) where the current TC is changed.
- If a Clip after the Current Clip is deleted, the tape is cued up to the same position (same picture) as the Current Clip.
- If any Clip exists when the Current Clip is deleted, tape cues up to the IN point of the next Clip.
- Upon completion of deletion of the Current Clip that is the last Clip, the tape is cued up to the OUT point of the previous Clip.
- If the Current Clip is deleted when any Clip does not exist, the picture becomes all black.
- When a Clip is going to be deleted, any extension (such as .dlt) should not be added to the file to be deleted, on the command.
- When a Playlist is going to be deleted, an extension (such as .dlt) should be added to the file to be deleted, on the command.

Command format

Item	Size	Value	Description
DC	1	0xXX	Data Count
CMD1	1	0x13	Command1
CMD2	1	0x03	Command2
DATA1	1	0x00	DRIVE ID
DATA2	n	0xXX..	FILE NAME

DRIVE ID Fixed to 0x00

FILE NAME Filename to be deleted

SYSTEM STATUS	Value	Description
Command Status	0x03	DELETE
Execution Status	0x00	COMPLETE
	0x01	IN PROGRESS
	0x02	FAIL
	0x21	FAIL, SOURCE FILE IS NOT EXIST
	0x23	FAIL, THE FILE IS OPEN

(2) DELETE Sequence

In the DSR-DR1000, a series of the commands expected to be issued and executed as described below as the correct sequence of the DELETE operation.

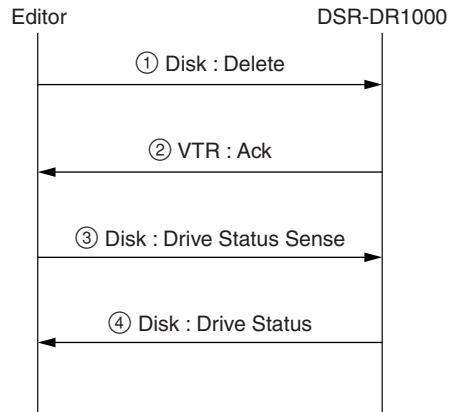

In the DSR-DR1000, the command of the DELETE command that is used to check the error, becomes the Drive Status. The identification number of the command is entered in the CMD STATUS that is the 0th status of the Drive Status Table. Result of the execution is reflected on the 1st status that is the EXEC STATUS.

(3) Example of the Cue Up Position for Your Reference

Examples of the CLIPs that are displayed on the PLAY side after receipt of the DELETE command and upon completion of DELETE of the CLIP, are shown below your reference.

Examples numbers 1 through 7 are the examples in the status when CLIP00001/CLIP00002/CLIP00003/CLIP00004/CLIP00005 exist.

Example number 8 is the example in the status when CLIP00001 only exists.

No.	Current Clip	Clip to be Deleted	Cue Up Clip
1	CLIP00003	CLIP00003	CLIP00004 IN point
2	CLIP00001	CLIP00001	CLIP00002 IN point
3	CLIP00005	CLIP00005	Number of CLIP00004 OUT points
4	CLIP00003	CLIP00001	CLIP00003 TC only changes.
5	CLIP00003	CLIP00002	CLIP00003 TC only changes.
6	CLIP00003	CLIP00005	CLIP00003 does not change.
7	CLIP00003	CLIP00004	CLIP00003 does not change.
8	CLIP00001	CLIP00001	BLACK

4. Sense Command

The Sense Request and the Sense Return of the Disk command that are supported by the DSR-DR1000 are shown below.

(1) DRIVE STATUS SENSE

In the DSR-DR1000, the DRIVE STATUS SENSE is the command that aims at inquiring the DRIVE STATUS (aiming at confirmation of the processing status of the DELETE command, and aiming at confirmation of the remaining free capacity of the recording hard disk (to be abbreviated simply as HD hereafter)).

Command format

Item	Size	Value	Description
DC	1	0x03	Data Count
CMD1	1	0x14	Command1
CMD2	1	0xD0	Command2
DATA1	1	0x00	DRIVE ID
DATA2	1	0xFF	DRIVE STATUS TABLE No.
DATA3	1	0xFF	LENGTH

Requests that cannot be accepted due to their contents

1. Requesting the Data Count using a value other than 0x03.
2. Requesting the DRIVE ID using a value other than 0x00.
3. Requesting the LENGTH using a value of 254 or more.
4. Requesting the DRIVE STATUS TABLE No. + LENGTH using a value of 257 or more.

If any request having the above-described contents is issued, the DRIVE STATUS is returned as "DRIVE STATUS (without any additional data)"

(2) DRIVE STATUS

In the DSR-DR1000, the DRIVE STATUS is the status that aims at the replies for the inquiry of the DELETE processing status and inquiry for the remaining capacity of HD.

Command format

Item	Size	Value	Description
DC	1	0xFF	Data Count
CMD1	1	0x15	Command1
CMD2	1	0xD0	Command2
DATA1	1	0xFF	DRIVE ID
DATA2	1	0xFF	DRIVE STATUS TABLE No.
DATA3	1	0xFF	DRIVE STATUS VALUE

DC Received with DRIVE STATUS SENSE. The LENGTH + 2 (DRIVE ID/ DRIVE STATUS TABLE No.)

DRIVE ID Received with DRIVE STATUS SENSE. The DRIVE ID value

DRIVE STATUS TABLE No. Received with DRIVE STATUS SENSE. The DRIVE STATUS TABLE No. value

DRIVE STATUS VALUE DRIVE STATUS TABLE DATA as many as the number of the LENGTHs starting from the TABLE NUMBER specified by the DRIVE STATUS SENSE.

Items that are set in the DSR-DR1000.

- TableNo.0 : Command Status
- TableNo.1 : Exec Status
- TableNo.32-39 : VIDEO REMAIN SIZE (The same value as that of AUDIO)
- TableNo.40-47 : AUDIO REMAIN SIZE (The same value as that of VIDEO)

DRIVE STATUS TABLE

Category	Table No.	Size	ID = 0	ID! = 0	Item
COMMAND STATUS	000	1	OK	NG	CMD STATUS
	001	1	OK	NG	EXEC STATUS
AV REMAINING SIZE	032-039	8	OK	OK	VIDEO REMAINING SIZE
	040-047	8	OK	OK	AUDIO REMAINING SIZE

OK : senses valid value.

NG : senses value which is not valid.(e.g.0x00)

For all items other than what are listed above, these items are filled with 0x00 to make up the DRIVE STATUS VALUE.

If there is any abnormality in the DRIVE STATUS SENSE request, the DRIVE STATUS VALUE will not added by setting DC = 0x00.

(3) FILE SYSTEM DATA SENSE

In the DSR-DR1000, the FILE SYSTEM DATA SENSE is the command that aims at inquiry of the FILE SYSTEM DATA (File Entry for DSR-DR1000).

The FILE SYSTEM DATA SENSE command is issued in order to obtain the return which is the File Entry Data that tells the host system the Clips in the DSR-DR1000, the Playlist created by VFL and the Playlist information that is created by the Front Panel and then saved.

The host system that wants to use this command must recognize that the maximum number of the File Entries of the DSR-DR1000 is 507 and at the same time every single File Entry consists of 112 bytes.

Command format

Item	Size	Value	Description
DC	1	0x0X	Data Count
CMD1	1	0x14	Command1
CMD2	1	0x81	Command2
DATA1	1	0x00	DRIVE ID
DATA2	1	0xXX	AREA CODE
DATA3	4	0XXXXXXXX	START ADDRESS
DATA4	1	0xXX	LENGTH

Requests that cannot be accepted due to their contents

1. Any value other than 0x10 (File Entry) is used for inquiring AREA CODE
2. Any value other than 225 (2 File Entry) is used for inquiring LENGTH.
3. Any value other than 56784 (507 * 112) is used for inquiring START ADDRESS.
4. Any value other than 113 is used for inquiring LENGTH when the START ADDRESS is located at the last position (0xDD60).
5. Any value other than 113 is used for inquiring the (START ADDRESS % 112) + LENGTH.
6. Any value other than 225 is used for inquiring LENGTH when the START ADDRESS is in multiples of 112 (not including the last address).

If the request cannot be accepted due to their contents, only the FILE SYSTEM DATA is returned as the reply with the "FILE SYSTEM DATA(with no additional data)".

(4) FILE SYSTEM DATA

In the DSR-DR1000, the FILE SYSTEM DATA is the status that aims at the reply for the DSR-DR1000 File Entry.

Command format

Item	Size	Value	Description
DC	1	0xXX	Data Count
CMD1	1	0x15	Command1
CMD2	1	0x81	Command2
DATA1	1	0x00	DRIVE ID
DATA2	1	0xXX	AREA CODE
DATA3	4	0XXXXXXXX	START ADDRESS
DATA4	n	0xXX	FILE SYSTEM DATA

DC Received with FILE SYSTEM DATA SENSE. The LENGTH + 6 (DRIVE ID + AREA CODE + START ADDRESS)

DRIVE ID Received with FILE SYSTEM DATA SENSE. The DRIVE ID

AREA CODE Received with FILE SYSTEM DATA SENSE. The AREA CODE

START ADDRESS Received with FILE SYSTEM DATA SENSE. The START ADDRESS

FILE SYSTEM DATA Received with FILE SYSTEM DATA (File Entry Data for the specified Playlist)

The items that are supported as the File Entry in the DSR-DR1000 are identified by the round marks (○) and by the triangle marks(△) in the following table.

At the same time, the items that are shown with the crossing mark (×) are filled with 0x00 to create the FILE SYSTEM DATA.

ITEM		SIZE (Byte)	VALUE	INDEX	GATHER
FILE_NAME		24		0-23	○
FILE_ATR		2	0x8005	24-25	△
WCF		2		26-27	×
GROUP		2		28-29	×
OWNER		2		30-31	×
RE_V		4		32-35	×
I-NODE		2	0xFFFF	36-37	△
CA_PROTECT		2	0x01FF	38-39	△
CA_ATR_AV	INFO	1		40	×
	A_CH	1		41	×
	SECT	2		42-43	×
CA_ATR_V	TYPE	1		44	×
	FRM	1		45	×
	SECT	2		46-47	×
CA_ATR_A1	TYPE	1		48	×
	BRR	1		49	×
	SECT	1		50	×
	SMPL	1		51	×
CA_ATR_A2 to A8		28		52-79	×
CA_SIZE_V		8		80-87	○
CA_DATE		4		88-91	×
CA_TIME		4		92-95	×
CA_DUR		4		96-99	○
CA_STC		4		100-103	○
CA_SOM		4		104-107	○
CA_EOM		4		108-111	○

The items whose VALUES are shown in the above table are set to the fixed values. The items of CA_STC and the CA_SOM are set to the fixed value of 00:00:00:00. The items CA_SIZE_V and CA_EOM are set to the values which are calculated from Duration.

(5) SYSTEM STATUS SENSE

In the DSR-DR1000, the SYSTEM STATUS SENSE is the command that aims at inquiry of the SYSTEM STATUS (inquiring the VFL DOWNLOAD processing status check).

Command format

Item	Size	Value	Description
DC	1	0x04	Data Count
CMD1	1	0x11	Command1
CMD2	1	0xD0	Command2
DATA1	2	0xXX 0xXX	TABLE NUMBER (Lower) TABLE NUMBER (Upper)
DATA2	2	0xXX 0xXX	REQUEST LENGTH (Lower) REQUEST LENGTH (Upper)

Requests that cannot be accepted due to their contents

1. Requesting the DC using a value other than 0x04.
2. Requesting the TABLE NUMBER + REQUEST LENGTH using a value of 1025 or more
3. Requesting the REQUEST LENGTH using a value of 254 or more.

If any request having the above-described contents is issued, the SYSTEM STATUS is returned as “SYSTEM STATUS (without any additional data)”

(6) SYSTEM STATUS

In the DSR-DR1000, the SYSTEM STATUS is the status that aims to inquiring the processing status of the VFL DOWNLOAD.

Command format

Item	Size	Value	Description
DC	1	0xXX	Data Count
CMD1	1	0x12	Command1
CMD2	1	0xD0	Command2
DATA1	2	0xXX 0xXX	TABLE NUMBER (Lower) TABLE NUMBER (Upper)
DATA2	n	0xXX	STATUS TABLE DATA

DC Received with SYSTEM STATUS SENSE. The REQUEST LENGTH + 2 (TABLE NUMBER)

TABLE NUMBER Received with SYSTEM STATUS SENSE. The TABLE NUMBER value

STATUS TABLE DATA The SYSTEM STATUS TABLE DATA as many as the number of REQUEST LENGTHs starting from the TABLE NUMBER specified by the SYSTEM STATUS SENSE

The items that are set in the DSR-DR1000

TableNo.544 : Command Status

TableNo.545 : Exec Status

SYSTEM STATUS TABLE

Category	Size	Item (MAV-555/2000)	Item (MAV-1000/1200)	Initial Value
COMMAND STATUS (544-549)	1	CMD STATUS		0xFF
	1	EXEC STATUS		0x00

For all items other than what are listed above, these items are filled with 0x00 to make up the STATUS TABLE DATA.

If there is any abnormality in SYSTEM STATUS SENSE request, the STATUS TABLE DATA will not added by setting DC = 0x00.

(7) FILE ENTRY DATA SENSE

In the DSR-DR1000, the FILE ENTRY DATA SENSE is the command that aims at inquiry of the FILE ENTRY DATA (File Entry while recording/playback is in progress).

Command format

Item	Size	Value	Description
DC	1	0x03	Data Count
CMD1	1	0x1A	Command1
CMD2	1	0x82	Command2
DATA1	1	0xXX	FILE HANDLE
DATA2	1	0xXX	TABLE NUMBER
DATA3	1	0xXX	REQUEST LENGTH

Requests that cannot be accepted due to their contents

1. Requesting the FILE HANDLE using a value other than 0x00.
2. Requesting the TABLE NUMBER + REQUEST LENGTH using a value more than 113.

If any request having the above-described contents is issued, the FILE ENTRY DATA is returned as “FILE ENTRY DATA (without any additional data)”

(8) FILE ENTRY DATA

In the DSR-DR1000, the FILE ENTRY DATA is the status that aims at the reply against the inquiry for the File Entry while recording/playback is in progress.

Command format

Item	Size	Value	Description
DC	1	0xXX	Data Count
CMD1	1	0x1B	Command1
CMD2	1	0x82	Command2
DATA1	1	0xXX	FILE HANDLE
DATA2	1	0xXX	TABLE NUMBER
DATA3	n	0xXX	FILE ENTRY DATA

DC Received with FILE ENTRY DATA SENSE. The REQUEST LENGTH + 2 (FILE HANDLE + TABLE NUMBER)

FILE HANDLE Received with FILE ENTRY DATA SENSE. The FILE HANDLE value.

TABLE NUMBER Received with FILE ENTRY DATA SENSE. The TABLE NUMBER value.

FILE ENTRY DATA FILE ENTRY DATA as many as the number of the REQUEST LENGTHs starting from the TABLE NUMBER that is specified by FILE ENTRY DATA SENSE.

* For the FILE ENTRY DATA, refer to the FILE SYSTEM DATA.

[Method of selecting the FILE ENTRY DATA depending on the mode and status]

During recording in the MODE	The CLIP File Entry information is set in the FILE ENTRY DATA during recording.
During playback in the VTR MODE (default.dlt)	The CLIP File Entry information is set in the FILE ENTRY DATA during playback.
During playback in the VTR MODE (Playlist)	The CLIP File Entry information is set in the FILE ENTRY DATA during playback.
During CLOSE in the VTR MODE	Returning the FILE ENTRY DATA without the FILE ENTRY DATA.
During playback in the other MODEs (default.dlt)	The CLIP File Entry information is set in the FILE ENTRY DATA during playback.
During playback in the other MODEs (Playlist)	The Playlist File Entry information is set in the FILE ENTRY DATA during playback.
During CLOSE in other MODEs	Returning the FILE ENTRY DATA without the FILE ENTRY DATA.

(9) CURRENT TIME SENSE

In the DSR-DR1000, the CURRENT TIME SENSE is the command that aims at inquiry of the Current Time of the present status (when recording/playback is in progress).

Command format

Item	Size	Value	Description
DC	1	0x02	Data Count
CMD1	1	0x1A	Command1
CMD2	1	0xC0	Command2
DATA1	1	0xXX	FILE HANDLE
DATA2	1	0xXX	REQUEST TIME BIT MAP

REQUEST TIME BIT MAP

BIT7	BIT6	BIT5	BIT4	BIT3	BIT2	BIT1	BIT0
0	0	0	0	0	VITC	LTC	FTC

Requests that cannot be accepted due to their contents

1. Requesting the DC using a value other than 0x02.
2. Requesting the FILE HANDLE using a value other than 0x00.
3. Requesting the REQUEST TIME BIT MAP using a value other than 1 through 7.

If any request having the above-described contents is issued, the CURRENT TIME is returned as “CURRENT TIME (without TIME data)”

(10) CURRENT TIME

In the DSR-DR1000, the CURRENT TIME is the status that aims at returning the Current Time of the present status (while recording/playback is in progress).

Command format

Item	Size	Value	Description
DC	1	0xXX	Data Count
CMD1	1	0x1B	Command1
CMD2	1	0xC0	Command2
DATA1	1	0xXX	FILE HANDLE
DATA2	1	0x0X	REQUEST TIME BIT MAP
DATA3	1	0x0X	READ STATUS BIT MAP
DATA4	4	0xXX	FTC (Frame)
		0xXX	FTC (Second)
		0xXX	FTC (Minute)
		0xXX	FTC (Hour)
DATA5	8	0xXX	LTC (Frame)
		0xXX	LTC (Second)
		0xXX	LTC (Minute)
		0xXX	LTC (Hour)
		0xXX	LTC BINARY GROUP
		0xXX	LTC BINARY GROUP
		0xXX	LTC BINARY GROUP
		0xXX	LTC BINARY GROUP
DATA6	8	0xXX	VITC (Frame)
		0xXX	VITC (Second)
		0xXX	VITC (Minute)
		0xXX	VITC (Hour)
		0xXX	VITC BINARY GROUP
		0xXX	VITC BINARY GROUP
		0xXX	VITC BINARY GROUP
		0xXX	VITC BINARY GROUP

REQUEST TIME BIT MAP Received with CURRENT TIME SENSE. The REQUEST TIME BIT MAP value.

FTC/LTC/VITC Value of each TIME CODE (BCD format)

READ STATUS BIT MAP

BIT7	BIT6	BIT5	BIT4	BIT3	BIT2	BIT1	BIT0
0	0	0	0	0	VITC MISS	LTC MISS	FTC MISS

* It sets the bit for the TC that is not specified by the REQUEST TIME BIT MAP.

(11) FILE OPEN STATUS SENSE

In the DSR-DR1000, the FILE OPEN STATUS SENSE is the command that aims at inquiry of the FILE OPEN STATUS (status of OPEN PLAY).

Command format

Item	Size	Value	Description
DC	1	0x01	Data Count
CMD1	1	0x10	Command1
CMD2	1	0x43	Command2
DATA1	1	0xXX	PORT ID

In the DSR-DR1000, PORT ID of the FILE OPEN STATUS SENSE is ignored.

(12) FILE OPEN STATUS

In the DSR-DR1000, the FILE OPEN STATUS is the status that aims at inquiry of the processing status of OPEN PLAY.

Command format

Item	Size	Value	Description
DC	1	0x0X	Data Count
CMD1	1	0x18	Command1
CMD2	1	0x00	Command2
DATA1	1	0xXX	PORT ID
DATA2	1	0xXX	FILE OPEN STATUS
DATA3	1	0x00	FILE OPEN MODE
DATA4	1	0x00	FILE HANDLE
DATA5	1	0x00	TRANSFER SPEED

DC It varies depending on the FILE OPEN STATUS.
PORT ID PORT ID that is received with the FILE OPEN STATUS SENSE
FILE OPEN STATUS Status of OPEN PLAY
FILE OPEN MODE 0x00
FILE HANDLE 0x00
TRANSFER SPEED 0x00

In the DSR-DR1000, the FILE HANDLE takes the value of 0x00 only. Because the OPEN-related commands are not supported except OPEN PLAY, the FILE OPEN MODE takes the value of 0x00 only. The TRANSFER SPEED is not used actually, but because it is necessary due to the command format, 0x00 is entered.

This command contains a data in which bit rate is going to be set. Because the OPEN REC and so on are not supported in the DSR-DR1000, it is not described.

If the OPEN PLAY command is not sent to the DSR-DR1000 even once, the FILE OPEN STATUS becomes 0x01.

7-3. Items supported from DSR-DR1000/A disk command V2.00

1. Open Play Command supporting ENDLESS MODE

In V2.00 or later, by setting ENDLESS MODE that exists in the Option of the Open Play Command, an opened file can be played back repeatedly.

Description of Open Play Commands is as follows:

Item	Size	Value	Description
DC	1	0xXX	Data Count
CMD1	1	0x16	Command1
CMD2	1	0x00	Command2
DATA1	1	0xXX	PORT ID
DATA2	1	0xXX	OPTION
DATA3	1	0xXX	DRIVE ID
DATA4	n	0xXX	FILE NAME
DATA5	3	0xXX	CHANNEL BITMAP 1
		0xXX	CHANNEL BITMAP 2
		0xXX	CHANNEL BITMAP 3
DATA6	4	0xXX	START TIME CODE (Frames)
		0xXX	START TIME CODE (Seconds)
		0xXX	START TIME CODE (Minutes)
		0xXX	START TIME CODE (Hours)
DATA7	4	0xXX	DURATION (Frames)
		0xXX	DURATION (Seconds)
		0xXX	DURATION (Minutes)
		0xXX	DURATION (Hours)

- PORT ID : The DSR-DR1000/A ignores this value.
- OPTION : Specify Option by bit.
- DRIVE ID : Set as 0x00.
- FILE NAME : Specify a playlist or a CLIP to be opened.
- CHANNEL BITMAP : Ignored in the DSR-DR1000/A.
- START TIME CODE : Four-byte, BCD-format TIMECODE data.
- DURATION : Ignored in the DSR-DR1000/A.

The setting of the Option described above is as follows:

BIT7	BIT6	BIT5	BIT4	BIT3	BIT2	BIT1	BIT0
	0		(*4)	0	(*3)	(*2)	(*1)

- *1: Select whether or not to specify CHANNEL. (Ignore Bit even when it is 1. However match Data's offset.)
 - 0 : Do not specify CHANNEL.
 - 1 : Specify CHANNEL.
- *2: Select whether or not to specify the START position.
 - 0 : Do not specify the START position.
 - 1 : Specify the START position.
- *3: Select whether or not to specify DURATION. (Ignore Bit even when it is 1.)
 - 0 : Do not specify DURATION.
 - 1 : Specify DURATION.
- *4: Select whether or not to enable ENDLESS MODE. (Specifying this Bit activates Repeat Play.)
 - 0 : ENDLESS MODE OFF
 - 1 : ENDLESS MODE ON

Before V2.00, only the START position could be specified, but in V2.00 or later, the ENDLESS MODE can also be selected.

The ENDLESS MODE can be specified in the OPEN created in the CLIP unit and the File created by the commands such as the VFL Download Command.

When performing Open Play by specifying a CLIP while the ENDLESS MODE is specified, only the specified CLIP is played back repeatedly. When this opened file is played back, "REPEAT PLAY" is displayed on the OSD.

When performing Open Play by specifying a VFL and the ENDLESS MODE is specified, repeat play-back is performed according to the description of the file created by the VFL. When this opened file is played back, "VFL RPT. PLAY" is displayed on the OSD.

When performing Open Play by specifying the ENDLESS MODE, an error occurs in the File Open Status in the following cases:

Status	Value	Description
0x15	FAIL, ILLEGAL VALUE	The START position cannot be found.
0x1F	FAIL, OTHER REASONS	Memory for repeating cannot be secured.

Note

Since the Endless Mode is supported, do not create VFL with the following file names: "default.dlt" "Ciplist0.dlt" "RepeatTmp.dlt" "RepeatClipXX.dlt" "RepeatVFLXX.dlt" (Do not leave out ".dlt" from the above file names. "XX" in "RepeatClipXX.dlt" and "RepeatVFLXX.dlt" must be 00 to 99.)

2. Correction of the CLOSE Command

In V2.00 or later, VFL can be downloaded during the CLOSE state. In V1.10 or later, at CLOSE after opening the VFL, a VFL that has the same name with the VFL that had been open could not be created.

3. “CR” and “LF” in the VFL DOWNLOAD SET Command

In V1.10 or later, “CR” and “LF” were handled oppositely in the VFL Download Set Command. In V2.00 or later, in consideration of compatibility, operation can be performed with both “CR” “LF”, and “LF” “CR”.

4. “Current Time” and “File Entry Data” for the R Port

In V1.10 or later, regardless of the R Port or the P Port, while recording in the VTR Mode, when “Current Time Sense” or “File Entry Data Sense” was transmitted, “Current Time” or “File Entry Data” was returned as the information of the CLIP being recorded. In V2.00 or later, the information of the CLIP being recorded and that of the PLAY are returned separately to the R Port and the P Port.

(1) Information of the R Port

• Current Time

While recording is not in progress, 0 is written to Data 4 to Data 6.

While recording is in progress, the TC information of the CLIP being recorded is written.

• File Entry Data

While recording is not in progress, all the Data become 0x00.

While recording is in progress, CLIP name is written to the File Name, the Disk size used in the CLIP is written to CA_SIZE_V, and the duration of the data is written to DiskCA_DUR.

(2) Information of the P Port

• Current Time

When the port is open, TC information corresponding to the screen currently displayed is input.

When the port is closed, “No Data” is returned.

• File Entry Data

When VFL is open, VFL name is written to the File Name, Disk size that supports the duration used in the VFL is written to CA_SIZE_V, and the duration of the opened VFL is written to CA_DUR.

When the port is closed, “No Data” is returned.

In other cases, the information on the CLIP currently displayed is returned.

5. VFL Download for the CLIP being recorded

In V1.10 or later, the CLIP being recorded could not be specified using the Text Data of the VFL Download Set Command.

In V2.00 or later, it can be specified using the VFL Download Set Command.

However, when specifying the CLIP being recorded, if an area not written in Disk is specified, the VFL Download Set Command fails. The area not written in Disk includes the area in which no data is recorded but will be recorded soon, and the information stored in the memory for creating REC information.

On the current system, it is assumed that there is the maximum of 10-frame delay of the data to be written from the frame displayed on the screen to the Disk.

Also, the CLIP being recorded that can be specified in the VFL is the one that can perform Time-shift playback. The CLIP that is performing LOOP REC is not supported.

7-4. Special Commands for HVR Series

In the HVR series, the extension commands are located in the DEVICE DEPENDENT area of the 9-pin command table.

These commands interpret DATA-1 as CMD-3.

7-4-1. Command Table

COMMAND	RETURN	HVR-1500	HVR-1500A
0X•FA•E5 : EXTEND VIDEO INPUT SELECT	10•01 : ACK	×	○
01•FB•E5 : EXTEND VIDEO INPUT SENSE	14•FB•E5 : EXTEND VIDEO INPUT STATUS	×	○

7-4-2. Detailed Description of Commands

0X•FA•E5 : EXTEND VIDEO INPUT SELECT

This command is used to select a video input source according to DATA-2 to DATA-4.

When DATA-4 is omitted and “0x00” is set, the default HD/SD setting of the model is selected.

[DATA-2]

BIT-7	BIT-6	BIT-5	BIT-4	BIT-3	BIT-2	BIT-1	BIT-0
INTERNAL SG						SDI	ANALOG

[DATA-3]

BIT-7	BIT-6	BIT-5	BIT-4	BIT-3	BIT-2	BIT-1	BIT-0
			S (Y/C)			Y/Pb/Pr	COMPOSITE

[DATA-4]

This data can be omitted.

When this data is provided, specify the HD or SD mode according to DATA-4.

This data is invalid when specified input function is not provided due to no optional board, etc.

BIT-1	BIT-0	MODE
0	1	HD
1	0	SD

Note

The DATA-4 setting is valid in the following cases.

- When DATA-2 BIT-1 “SDI” is set
- When DATA-2 BIT-0 “ANALOG” and DATA-3 BIT-1 “Y/Pb/Pr” are set

01•FB•E5 : EXTEND VIDEO INPUT SENSE

This command is used to inquire video input selection status.

Send back the “14•FB•E5 : EXTEND VIDEO INPUT STATUS” command to see the setting in DATA-2 to DATA-4.

14•FB•E5 : EXTEND VIDEO INPUT STATUS

This command is used to send video input selection information in response to the “01•FB•E5 : EXTEND VIDEO INPUT SENSE” command. This command sends back input connector selection status in DATA-2, signal format in DATA-3, and HD/SD information in DATA-4 as follows:

[DATA-2]

BIT-7	BIT-6	BIT-5	BIT-4	BIT-3	BIT-2	BIT-1	BIT-0
INTERNAL SG			i.LINK			SDI	ANALOG

[DATA-3]

BIT-7	BIT-6	BIT-5	BIT-4	BIT-3	BIT-2	BIT-1	BIT-0
			S (Y/C)			Y/Pb/Pr	COMPOSITE

[DATA-4]

BIT-1	BIT-0	MODE
0	1	HD
1	0	SD

8. Time Data Format

The following shows the time data format used by commands such as “24•31 : CUE UP WITH DATA”.

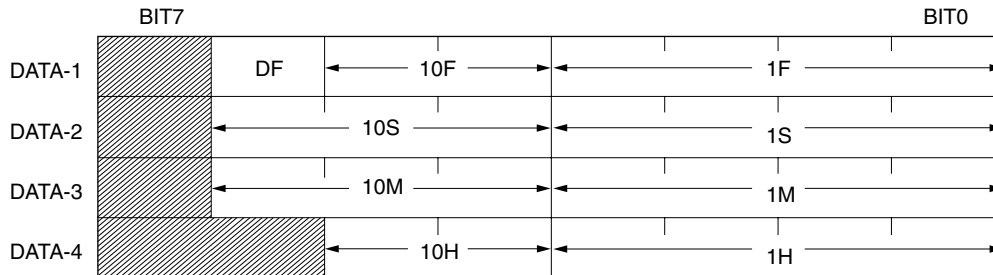

Although the shaded null bits have no meaning as time data, they are set in the following cases.

- DATA 1 BIT-6 : DF FLAG (“1” DF, “0” NDF)...Only for NTSC model
 This bit is set in a response command from DEVICE of “61•0C : CURRENT TIME SENSE” according to the DF or NDF mode of DEVICE.
 It is also set to specify the DF or NDF mode of the TIME CODE GENERATOR of DEVICE of “44•04 : TIME CODE PRESET”.
- Other bits
 The other bits are defined by SMPTE/EBU in a response command of TIME CODE DATA from DEVICE of “61•0C : CURRENT TIME SENSE”. Flags conforming to the TIME CODE FORMAT may be set.

9. Appendix-1

20•60 [FULL EE OFF], 20•61 [FULL EE ON], 20•63 [SELECT EE ON]
 20•64 [EDIT OFF], 20•65 [EDIT ON]
 4X•30 [EDIT PRESET]

Notices for the DEVICE that has editing function.

To execute above command accurately (on the specified tape address) in the normal playback mode, the following condition should be satisfied.

Select external video reference mode.

Send the command within 6 ms after the frame change timing.

The followings are the example of timing chart.

In this case, edit delay is 3 frames.

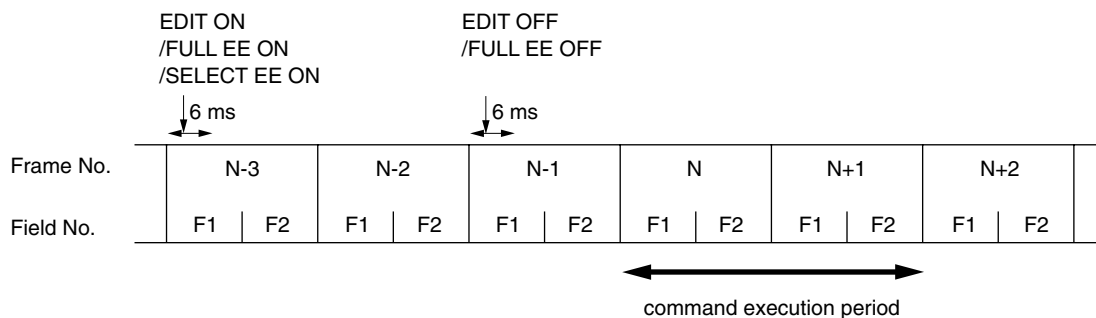

10. Appendix-2

(1) 44•04 [TIME CODE PRESET], 4X•05 [USER'S BIT PRESET]

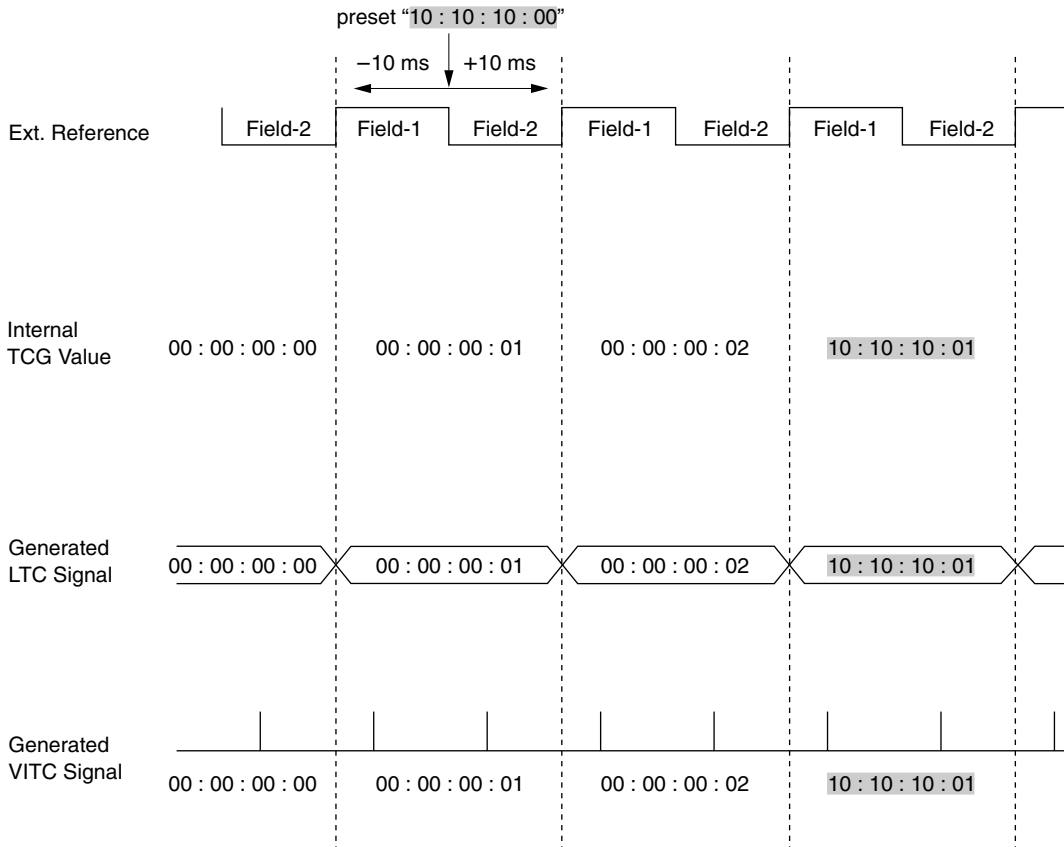

11. Appendix-3

(1) 40•C1 [TIMELINE RUN]

When the DEVICE is requested to execute operation exactly when the above-described command is given, the DEVICE should be locked to the external reference video signal and the target command transmitted within 2 ms of the switching point of frames of the external sync video signal, or within 2 ms of the end of the first field.

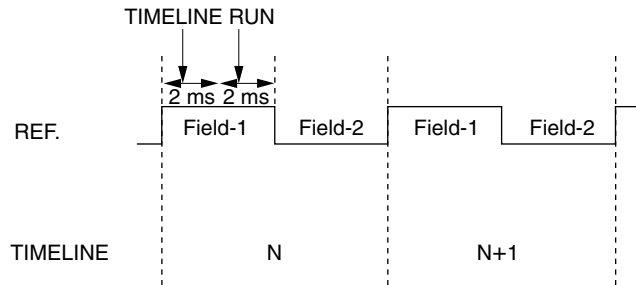

(2) 44•C3 [TIMELINE PRESET]

When the DEVICE is requested to execute operation exactly when the above-described command is given, the DEVICE should be locked to the external reference video signal and the target command transmitted within 2 ms of the switching point to the second field of the external sync video signal, or within 2 ms of the end of the second field.

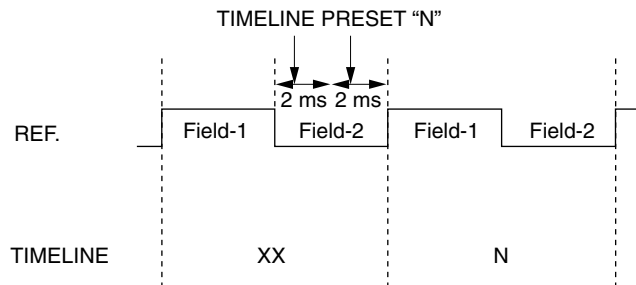

このマニュアルに記載されている事柄の著作権は当社にあります。

従って、当社の許可なしに無断で複写したり、説明内容(操作、保守等)と異なる目的で本マニュアルを使用することを禁止します。

The material contained in this manual consists of information that is the property of Sony Corporation. Sony Corporation expressly prohibits the duplication of any portion of this manual or the use thereof for any purpose other than the operation or maintenance of the equipment described in this manual without the express written permission of Sony Corporation.

Le matériel contenu dans ce manuel consiste en informations qui sont la propriété de Sony Corporation. Sony Corporation interdit formellement la copie de quelque partie que ce soit de ce manuel ou son emploi pour tout autre but que des opérations ou entretiens de l'équipement à moins d'une permission écrite de Sony Corporation.

Das in dieser Anleitung enthaltene Material besteht aus Informationen, die Eigentum der Sony Corporation sind. Die Sony Corporation untersagt ausdrücklich die Vervielfältigung jeglicher Teile dieser Anleitung oder den Gebrauch derselben für irgendeinen anderen Zweck als die Bedienung oder Wartung der in dieser Anleitung beschriebenen Ausrüstung ohne ausdrückliche schriftliche Erlaubnis der Sony Corporation.

DSR-60
DSR-60P
DSR-70
DSR-70P
DSR-70A
DSR-70AP
DSR-80
DSR-80P
DSR-85
DSR-85P
DSR-1500
DSR-1500A
DSR-1500P
DSR-1500AP
DSR-1600
DSR-1600A
DSR-1600P
DSR-1600AP
DSR-1800
DSR-1800A
DSR-1800P
DSR-1800AP
DSR-2000
DSR-2000A
DSR-2000P
DSR-2000AP
DSR-DR1000
DSR-DR1000A
DSR-DR1000P
DSR-DR1000AP
HVR-1500
HVR-1500A (CE, UC, CN) E
9-955-140-09

Sony Corporation

Printed in Japan
2008. 6 16
©1997