

# Sunbeam®

---

## Food Steamer

*Instruction Book and Recipe Book*

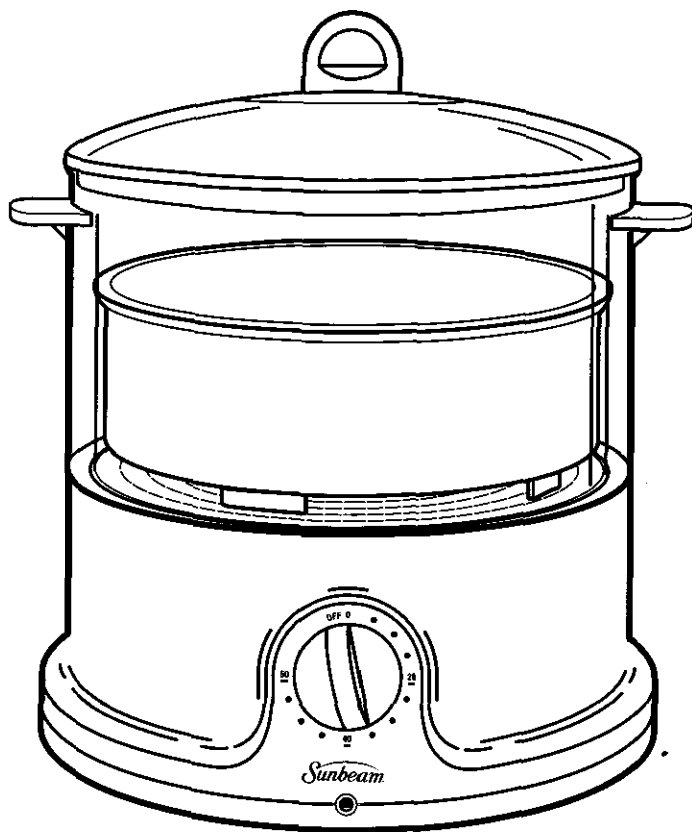

Model #4713



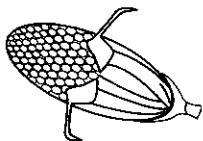

**Congratulations**, you are now the owner of a Sunbeam Food Steamer, and will soon be creating complete, flavorful, healthy meals with steam heat! Steaming retains the vitamins and minerals in foods that are often lost with other cooking methods. Nutritious dishes are minutes away without added oil or fat. Cook fish and fowl, vegetables, rice, and even quick breads with ease of preparation and clean-up. Entire meals can be cooked in the large steamer bowl, without greasy pots and pans or burnt-on food to clean up afterwards. And, with our "Instant Steam" technology, your Food Steamer will be producing steam in less than a minute! The following pages contain simple recipes and guidelines for perfect steam cooking. Practice with steaming vegetables and then move on to more sophisticated dishes. Use your imagination to create exciting recipes with healthy steam heat!

To reduce the risk of electric shock, this appliance has a polarized plug (one blade is wider than the other). This plug will fit in a polarized outlet only one way. If the plug does not fully fit into the outlet, reverse the plug. If it still does not fit, contact a qualified electrician to install the proper outlet. Do not change the plug in any way.

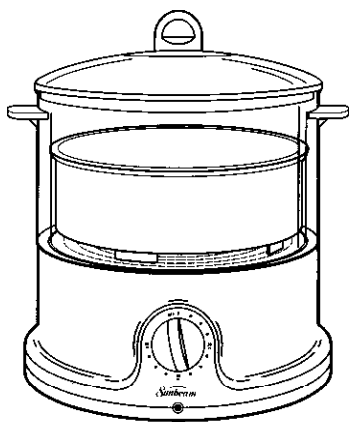

# IMPORTANT SAFEGUARDS

When using electrical appliances, basic safety precautions should always be observed including the following:

1. Read all instructions, product labels and warnings before using your Food Steamer. Save these instructions.
2. Do not touch hot surfaces. Use handles or knobs. Always use oven mitts when handling hot materials. Avoid hot steam rising from top of Steamer at all times when in use. Do not reach over appliance while it is generating steam. Remove lid by lifting slowly away from you. When checking food, use long handled utensils.
3. Allow the Food Steamer to cool completely before washing or storing.
4. Allow the unit to cool before putting on or taking off parts.
5. When unit is not in use and before cleaning, unplug the Food Steamer from the electrical outlet.
6. To protect against risk of electrical shock, do not immerse the appliance, cord, or plug in water or other liquids.
7. Close supervision is always necessary when this or any appliance is used by or near children.
8. Do not allow anything to rest on the power cord. Do not plug in cord where it may be walked on or accidentally tripped over. Do not let cord hang over edge of table or counter, or touch hot surfaces.
9. Do not operate this or any appliance with a frayed or damaged cord or plug or after the appliance malfunctions or is dropped or has been damaged in any manner. Return appliance to our Hattiesburg, MS Service Center for servicing or repairs. See page 13.
10. Do not use outdoors.
11. Do not place on or near a hot gas or electric burner or in a heated oven or microwave.
12. Use extreme caution when moving the appliance if it contains hot water or any other hot liquids.
13. Do not operate appliance near walls or cabinets to prevent damage from steam.
14. Use the appliance on a level, stable work surface away from water.
15. Always use sufficient water for steaming time.
16. The use of accessory attachments not recommended by the appliance manufacturer may cause injuries.
17. Do not use appliance for other than intended use.
18. To disconnect, turn any control to "off", then remove plug from wall outlet.
19. Caution - To reduce risk of electric shock, cook only in removable container.

## SAVE THESE INSTRUCTIONS

# FOOD STEAMER COMPONENTS

A) STEAMER LID has a convenient handle on top to avoid burning fingers when it is removed. However, use caution when removing lid due to the small steam vents in the top of the cover which constantly emit hot steam when appliance is in use. Also be careful of the surge of steam that will result when cover is lifted. Lift cover away from person when opening. Use oven mitts **at all** times when **handling hot Steamer parts.**

B) STACKING STEAM BOWL comes with some models and is made of white plastic, has a 2 quart capacity and is placed on top of the steamer bowl when in use. It is used for cooking a second layer of food.

C) SEPARATOR RING divides the two steam bowls (B & F) and provides a seal and stability when using both bowls. **Never use your Stacking Bowl without the Separation Ring.**

D) ROUND CAKE PAN comes with some models and is made with a non-stick surface. It is placed inside the steaming bowl and is used to steam bake cakes. (See page 4 for further instructions.)

E) RICE BOWL is made of white plastic, has a 8.5 cup capacity, and is placed inside the Steamer Bowl when in use. It is used for cooking rice. This bowl may stain if tomato based food is Cooked in It.

F) STEAMER BOWL is made with clear plastic and has a 6 quart capacity.

G) DRIP TRAY prevents water condensation and food liquids from dripping back into the Water Reservoir to ensure that steam is always produced from clean water.

H) WATER RESERVOIR BASE holds water for steaming Do not use any other type of liquid in the reservoir.

I) TIMER operates up to sixty (60) minutes and includes a bell to indicate when cooking time expires.

J) INDICATOR LIGHT identifies when appliance is cooking.

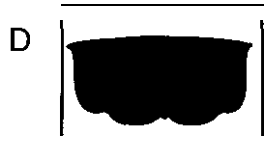
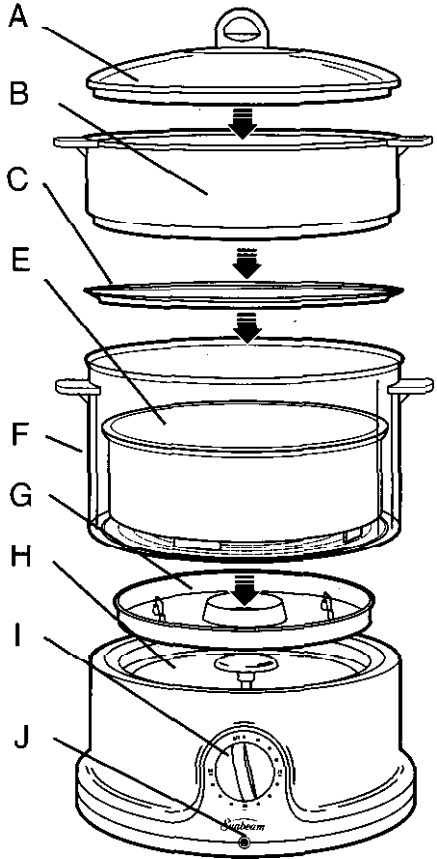

FOR HOUSEHOLD USE ONLY

## COOKING WITH YOUR FOOD STEAMER

1. Place the appliance on a stable, level surface away from walls and overhanging cupboards.
2. Pour cold tap water into Water Reservoir to Max level for foods requiring 13 to 60 minutes steaming time, or Min level for food requiring less than 13 minutes. See Figure 1. Min and Max levels are indicated by raised lines in the Water Reservoir. Refer to Steaming Charts or Recipes for recommended cooking times. If the appliance stops producing steam, or there is a noticeable reduction in steam before food is ready, add extra water to the basin.

Note: Do not add any salt, pepper, seasonings, herbs, wine, stock or any liquid other than tap water to the Water Reservoir.

3. Place Drip Tray in base and be sure it sits flat.
4. Your appliance can be used in three ways:

**-Using the 6 quart Steaming Bowl alone** • Place food in Steaming Bowl then position the Bowl on the base. See Figure 2.

**\*Using two Steaming Bowls-** Place the largest pieces of food with the longest cooking time in the 6 quart bowl and position it on the base. Place the Separator Ring on the 6 quart bowl with the large, flat area facing up. If you can easily push the ring off of the 6 quart bowl, it is not positioned correctly. Then place Stacking Bowl on Separator Ring. See Figure 3.

**-Using the Rice Bowl** • Liquid such as water or stock is added together with rice in the Rice Bowl. The Steaming Bowl must be placed on the base first, then the Rice Bowl is placed inside the Steamer Bowl for use. See Figure 4. Measure the required quantity of rice and liquid in the Rice Bowl. Refer to steaming charts or recipes.

**-Using a cake or loaf pan** (included with some models) • Cakes and quick breads can be made in this steamer also. Pour cake or bread batter into greased pan and place pan in steaming bowl. Always place tin foil on top of pan and seal tightly before cooking. See Figure 5. Refer to steaming recipes on page 12.

5. Cover with lid.
6. Plug into wall outlet. Do not operate the appliance without the Steaming Bowl and lid in place.
7. Set timer for the recommended time. The Indicator Light will light up. Steaming will begin in less than a minute. Condensation during steaming is normal.

**NOTE:** The timer operates regardless of whether the unit is plugged into the electrical outlet or not. Be sure the indicator light is on when setting the timer.

**WARNING:** During use do not touch the base, steamer bowls, or lid as they get very hot. Always use oven mitts when handling the steamer.

8. When steaming is complete, the timer will give a single ring and automatically shut off the steaming function.
9. When you have finished using the appliance, unplug from the wall socket and leave to cool completely before removing the Drip Tray.

**WARNING:** Use caution when removing the Drip Tray. While other parts of the unit may be cool, the water in the Water Reservoir **and** the Drip Tray may still be very hot.

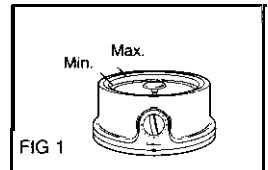

FIG 1

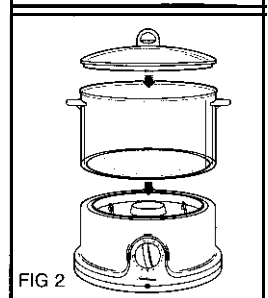

FIG 2

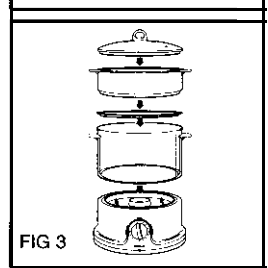

FIG 3

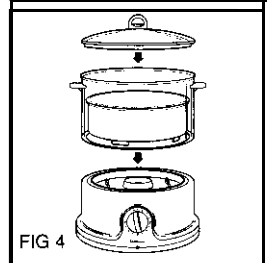

FIG 4

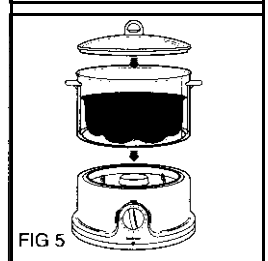

FIG 5

## *Useful Hints:*

- For high altitude cooking, steaming times may need to be increased. Exact times vary by location.
- \*Steaming times stated in the charts and recipes are only a guide. Times may vary depending on the size of food pieces, spacing of the food in the Steamer Bowl, freshness of food, and personal preference. As you become familiar with the Steamer, adjust cooking times.
- \*A single layer of food steams faster than several layers. Therefore, the cooking time for a larger quantity of food will be increased. For example, 2 lbs. of broccoli florets will need longer to steam than 1 lb.
- For best results, be sure pieces of food are similar in size. If pieces vary in size and layering is required, place smaller pieces on top.
- Do not crowd food in the Steaming Bowl or Rice Bowl. Arrange the food with spaces between pieces to allow for maximum steam flow.
- When steaming large quantities of food, remove lid about halfway **through** the steaming time and stir using a long handled utensil, protecting your hands from the steam with oven mitts.
- \*DO not add salt and seasoning to the Steaming Bowl until after COOKing. This is to avoid possible damage to the heating element located in the Water Reservoir.
- Save liquid in Drip Tray to use in soups, sauces, and gravies.
- Never steam meat or poultry from frozen. Always thaw completely first.
- \*All the times stated in the "Steaming Charts and Recipes" are based on the use of cold water in the Water Reservoir.
- \*The Rice Bowl is an ideal container for steaming other foods such as fruit, vegetables, puddings, quick breads, etc.

### *Using two Steaming bowls*

- Always place the largest pieces of food with the longest Cooking time in the lower bowl.
- You may place a different food in the stacking and lower bowls, but as condensation will drip from the stacking bowl be sure the flavors compliment each other.
- If steaming meat or poultry and vegetables, always place the meat or poultry in the lower bowl so that juices from raw or partially cooked meat cannot drip onto other foods.
- Steaming times for food in the stacking bowl are usually slightly longer so allow an extra 5 minutes.
- If foods with different cooking times are being steamed, start the food with the longest cooking time in the lower bowl. Then when the remaining steaming time reaches that of food with the shortest cooking time, carefully remove the lid with oven mitts and place the Separator **Ring** and stacking basket on top. Cover with lid and continue cooking.

## *Storage and Maintenance*

Allow appliances to cool completely before storing. Store Food Steamer in a dry location such as on a table top or counter top, or in a cupboard shelf. Wind the electrical cord into a coil and secure with a twist fastener.

Other than the recommended cleaning no further user maintenance should be necessary. Return the Food Steamer to our Hattiesburg MS, Service Center for servicing or repairs (See page 14).

## *Special Instructions*

This appliance has a short supply cord to reduce the risk resulting from becoming entangled in or tripping over a long cord. Longer extension cords are available and may be used if care is exercised in their use.

If a longer extension cord is used, the marked electrical rating of the cord set or extension cord should be at least as great as the electrical rating of the appliance. The cord should be arranged so that it will not drape over the counter top or tabletop where it can be pulled on by children or tripped over unintentionally.

## *Descaling the Water Reservoir*

After 2-3 months of consistent usage, chemical deposits may build up in the Water Reservoir and heating element inside your Food Steamer. This is a normal process and the build-up will depend on the degree of water hardness in your area. It is essential the appliance is descaled regularly to maintain steam production and extend the life of the unit.

1. Fill the Water Reservoir to the Max level with approximately 3 cups of clear vinegar (not brown vinegar). **IMPORTANT:** Do not use any other chemical or a proprietary descaler.
2. Plug in a wall socket. Drip tray, steamer bowl and lid should be in place during this procedure.
3. Set timer for 20-25 minutes to begin steaming. **WARNING:** If vinegar begins to boil over the edge of base, unplug the unit and switch the timer off. Reduce the quantity of vinegar slightly.
4. When the timer rings, unplug from the wall socket and allow to cool completely before pouring out vinegars.
5. Rinse the Water Reservoir several times with cold water. Clean other steamer parts as directed below.

## *TO CLEAN YOUR FOOD STEAMER.. .*

Before its first use, be sure to clean all parts of the Food Steamer as directed below to ensure cleanliness.

- NEVER IMMERSE THE BASE, CORD, OR PLUG IN WATER OR ANY OTHER LIQUID.
- Unplug at the wall socket and leave the appliance to cool completely before cleaning
- Do not clean any part of the unit with abrasive cleaners such as metal scouring pads, scouring powders, or bleach.
- We recommend washing the Steamer Lid, Rice Bowl, Round Cake Pan, Steamer Bowls, and Drip Tray in hot soapy water. Rinse and dry thoroughly. Alternatively, all these parts, except the Water Reservoir, can be cleaned in a dishwasher in the upper basket. However, continual cleaning in a dishwasher may result in a slight loss of exterior gloss and dulling.
- Empty the water basin and change the water after each use.
- Do not immerse the Water Reservoir in water. Fill it with warm, soapy water, then rinse thoroughly. Wipe dry with a soft cloth.



# Food Charts

## FRUITS AND VEGETABLES

•Cut off thick stems from broccoli, cauliflower, and cabbage.

\*Steam leafy green vegetables for the shortest possible time as they lose color easily.

\*Salt and season vegetables after steaming for best results.

frozen vegetables should not be thawed before steaming. Cooking time will vary from chart below.

FOOD	TYPE	QUANTITY	WATER LEVEL	STEAMING TIMES	SPECIAL NOTES
ARTICHOKES	Fresh	4Med	Max	45-50 min	Cut off base
ASPARAGUS	Fresh	1lb	Max	10-15 min	Lie flat in basket. Crisscross 2nd layer to allow steam flow
BABY SWEET CORN	Fresh	8oz	Max	30-35 min	Stir halfway through steam time.
BEANS,green	Fresh, whole	1lb	Max	35 min	Stir halfway through steam time.
BROCCOLI	Fresh, florets	1lb	Min	7-12 min	Remove stalk. Stir halfway through steam time.
BRUSSEL SPROUTS	Fresh	1lb	Max	25-30 min	Stir halfway through steam time.
CABBAGE	Fresh, sliced	1lb	Max	14-18 min	Stir halfway through steam time.
CARROTS	Fresh, 1/4 in.slices	1lb	Max	30 min	Stir halfway through steam time.
CAULIFLOWER	Fresh, florets	1lb	Max	11-14 min	Stir halfway through steam time.
CORN ON THE COB	Fresh	2-3 ears	Max	30-35 min	Turn each ear over halfway through cooking
MUSHROOMS,small	Fresh	8oz	Max Max	Quarter 15 min Whole 15-20 min	Stir halfway through steam time. Use stock for gravy or sauce.
PEACHES	Fresh	1lb	Min	10-12 min	Cut into slices. Stir halfway through steam time
PEARS	Fresh	2-4 whole	Max	12-15 min	Peel before steaming
PEAS	Frozen	1lb	Max	40 min	Stir halfway through steam time.
PEPPERS	Fresh	1lb	Max	10-15 min	Cut into strips. Stir halfway through steam time
PLUMS	Fresh	1lb	Min	10-12 min	Cut into quarters
POTATOES,new	Fresh, very small	1lb	Max	13-15 min	Turn each potato over halfway through cooking
POTATOES, baking	Fresh,cut into 2 oz pieces	11/2lb	Max	20-25 min	Turn each potato over halfway through cooking
SQUASH	Fresh	1lb	Max	13-15 min	Cut into bite-sized pieces. Stir halfway through steam time

## MEAT AND POULTRY

\*Steaming has the advantage of allowing all the fat to drip away during cooking. Due to the gentle heat only choose tender, lean cuts of meat and trim off all fat. Steam in Steam Bowl for best results.

-Serve steamed meat and poultry with flavorsome sauces or marinate before steaming.

\*Thoroughly cook all food before serving. Pierce with a knife or skewer to check that the center is cooked and juices run clear.

\*Sausage must be completely cooked before steaming

-Use fresh herbs while steaming to add flavor.

FOOD	TYPE	QUANTITY	WATER LEVEL	STEAM TIME	SPECIAL NOTES
BEEF	1/2 in. slices of rump, sirloin or fillet steak	1/2 lb	Min	8-10 min	Trim off all fat. Steamed beef has a firm texture
CHICKEN	Boneless breast	4 pieces 4 oz. each	Max	12-15 min	Remove skin before cooking. Layer for maximum steam flow.
	Drumsticks	4 pieces	Max	20-25 min	After steaming, brown skin in oven, if desired.
LAMB	Chops with or without bone	4 chops (3/4 in. thick)	Max	10-15 min	Trim off all fat.
	Loin cut into pieces	1 lb	Max	10-15 min	Trim off all fat.
PORK	Tenderloin, fillet, loin steaks or loin chops	1 lb or 4 pieces (1/2 in. thick)	Min	5-10 min	Trim off all fat.
SAUSAGES (precooked)	Frankfurters	1 lb	Min	11-13 min	Pierce skins before steaming
	Knockwurst	1 lb	Max	16-18 min	

-Cook rice and required quantity of liquid together in the Rice Bowl.

-3 cups of uncooked rice will make 8 1/2 cups cooked rice. Follow recipes below

FOOD	TYPE	QUANTITY RICE OR GRAIN	LIQUID	WATER LEVEL	STEAM TIME	SPECIAL NOTES
RICE	White fast cooking	1 cup	1 1/4 cups water	Min	10 min	Serves 3
	Brown	1 cup	1 1/4 cups water	Max	55-60 min	Serves 3
	White Slow cook	1 cup	1 1/4 cups water	Max	35 min	Serves 3

## FISH AND SEAFOOD

- Fish is done cooking when it is opaque and flakes easily with a fork.
- Frozen fish may be steamed without defrosting if separated before steaming and the cooking time is extended.
- Add lemon wedges and herbs while steaming to improve flavor.

FOOD	TYPE	QUANTITY	WATER LEVEL	STEAM TIME	SPECIAL NOTES
FISH, fillets	Sole	1/2 lb	Min	9-13 min	
	Cod, haddock, trout	1/2 lb	Min	5-10 min	
FISH, 3/4 in thick steaks	Cod, salmon	4 steaks	Max	15-18 min	
CLAMS	Fresh	1lb	Max	10-20 min	Layer shells for maximum steam flow. Steaming is done when shells are completely open.
LOBSTER, tails	Fresh	1 or 2 tails	Max	16-19 min	Meat will be opaque when done. Cook longer if necessary.
MUSSELS	Fresh	1lb	Min	6-12 min	Steaming is done when shells completely open.
OYSTERS	Fresh	6	Max	10-16 min	Steaming is done when shells completely open.
SCALLOPS	Fresh	1/2 lb	Min	10-13 min	Stir halfway through steam time. Meat opaque and flaky when done.
SHRIMP	Fresh	1/2 lb	Max	10-15 min	Meat will be opaque when done. Cook longer if necessary.

# RECIPES

## DINNERS

### TARRAGON CHICKEN BREASTS with GREEN BEANS AND SLICED ALMONDS

4 servings

4 4 oz. chicken breasts  
2 cups fresh green beans  
2 tablespoons chopped tarragon  
1/4 cup sliced almonds  
1 cup cream of chicken soup\*  
Salt and pepper to taste

Pour cream of chicken soup in Rice Bowl. Add chicken breasts sprinkled with tarragon, salt and pepper to taste. Arrange cleaned green beans and almonds in Steamer Bowl around Rice Bowl or in Stacking Bowl. Fill Water Reservoir to Max Level. Cover and Steam for 20-25 minutes.

\*Heavy cream can be substituted for cream of chicken soup if preferred.

### TROUT FILLETS WITH VEGETABLES

4 servings

4 trout fillets (6 oz. each)  
1/2 cup raw green beans  
4 slices lean bacon  
1/4 cup raw mushrooms, sliced  
2 raw carrots, sliced  
1/4 cup butter or margarine  
Salt and pepper to taste

Wash and peel the vegetables, and cut them into 1 1/4 inch sticks. Butter 4 pieces of aluminum foil and lay a slice of bacon, a trout fillet, and a quarter of the vegetables onto each one. Season with salt and pepper, and add a small pat of butter to each before wrapping in foil. Fill Water Reservoir to Max level. Place in Steaming Bowl, cover and steam for 15 minutes. Remove foil before serving.

### SALMON STEAKS WITH FENNEL

4 salmon steaks (5 oz. each)  
2 tbsp. fennel seeds  
1/4 cup butter or margarine  
Salt and pepper to taste  
Lemon juice to taste

Season the salmon steaks with salt and pepper. Sprinkle them with fennel and place in the Steaming Bowl. Fill Water Reservoir to Max level. Steam for 10-15 minutes. Separately melt the butter and add the lemon juice. Carefully remove the skin from the cooked salmon. Serve basted with melted butter and lemon juice.

## CREAMY SHRIMP AND RICE

4 servings

- 1 cup uncooked white or wild rice
- 2 tbsp. sliced green onions
- 1  $\frac{1}{4}$  cup chicken broth
- 1 cup frozen cooked shrimp
- 1  $\frac{3}{4}$  cup cream of potato soup
- 2 tbsp. sliced almonds, toasted
- $\frac{1}{2}$  cup shredded Swiss cheese
- Salt and pepper

Combine rice, chicken broth, potato soup, onions, cheese, shrimp, and salt and pepper in Rice Bowl. Stir well. Fill Water Reservoir to Max level. Steam for 60 minutes. Stir once while cooking. Garnish with sliced almonds.

## VEGETABLES

### VEGETABLES AU GRATIN

4 servings

- 1 cup raw carrots
- 1 cup celery
- $\frac{1}{4}$  cup butter or margarine
- $\frac{1}{4}$  cup grated cheddar cheese
- 2 raw baking potatoes
- Salt and pepper to taste

Peel the vegetables and cut them into 1  $\frac{1}{2}$  inch pieces. Place in Steaming Bowl. Fill Water Reservoir to Max level. Steam for 15 minutes. Remove from Steaming Bowl. While still piping hot, baste with butter or margarine, then sprinkle with cheese. Add salt and pepper to taste.

### FRENCH STYLE PEAS

4 servings

- 2 cups frozen peas
- 2 tbsp. butter or margarine
- 1 large onion
- 1 tbsp. thyme
- Salt and pepper to taste

Chop the onion, and add it to the frozen peas. Stir in thyme to the peas and onion. Place in Steaming Bowl. Fill Water Reservoir to Max level. Steam for 15 minutes. Save the liquid from the Drip Tray and mix it with the peas if desired. Mix in butter to hot peas. Add salt and pepper to taste.

### CAULIFLOWER AND CHIVES

4 servings

- 2 cups cauliflower florets
- 2 tbsp. chopped chives
- 1 cup cream
- Salt and pepper to taste

Place the cauliflower florets, cream, chives, and salt and pepper in the Rice Bowl. Fill Water Reservoir to Max level. Steam for 20 minutes. Stir once while cooking. Serve piping hot.

## DESSERTS

### RICE PUDDING

4 servings

1 1/2 cup fast cooking white rice  
1 tbsp. vanilla extract  
1 cup milk  
Raisins (optional)  
1/2 cup sugar

Combine rice, milk, sugar, vanilla extract, and raisins in Rice Bowl. Fill Water Reservoir to Max level. Steam for 35 minutes. Stir once while cooking.

### PEARS IN CHOCOLATE SAUCE

4 servings

4 whole pears  
1/2 cup low calorie cream  
Lemon half  
1 1/2 cup chocolate morsels

Peel the pears and rub them with lemon. Steam pears in Steamer Bowl for 15 minutes. Set aside to cool. In the Rice Bowl (covered with aluminum foil), melt the chocolate. Uncover, then add the cream and steam for 2-3 minutes uncovered. Drizzle pears with chocolate sauce and serve.

### STEWED APPLES WITH CINNAMON

4 servings

4 apples  
1/2 cup sugar  
Cinnamon to taste

Peel and core the apples. Cut them into quarters. Place the apples in the Steaming Bowl, and sprinkle with cinnamon. Fill Water Reservoir to Max level. Steam for 20 minutes. Remove the apples and mash them with a fork until blended. Stir in sugar and serve.

## **MIST & DELICIOUS MOLASSES CAKE**

2 cups flour  
1 cup water  
1/2 cup sugar  
1/2 cup molasses  
1/2 cup brown sugar  
1 teaspoon baking soda  
1/4 cup butter or margarine

Combine flour, sugar, brown sugar and butter or margarine in a bowl. Set aside 1/2 cup mixture for topping. Add water, molasses, and baking soda to large portion of crumb mixture. Pour into greased and floured 8" x 4" loaf pan. Sprinkle with remaining crumb mixture. Cover pan with aluminum foil to prevent water from entering. Be sure the foil creates a tight seal around the pan. Fill Water Reservoir to Max level. Place pan in Steaming Bowl. Steam for 60 minutes.

## **COFFEE CAKE**

1/2 cup margarine  
2 cups flour  
1 cup sugar  
1 1/2 teaspoons baking powder  
2 eggs  
1 teaspoon baking soda  
1 cup milk  
1 teaspoon vanilla  
cinnamon, to taste

Combine all ingredients except cinnamon in a bowl. Pour into greased and floured 8" x 4" loaf pan. Sprinkle with cinnamon. Cover pan with aluminum foil to prevent water from entering. Be sure the foil creates a tight seal around the pan. Fill Water Reservoir to Max level. Place pan in Steaming Bowl. Steam for 60 minutes. Sprinkle with more cinnamon when finished.

## **BANANABREAD**

1 1/2 cups flour  
2-3 ripe bananas mashed (1 cup)  
3/4 cup sugar  
1/2 cup margarine  
2 teaspoons baking powder  
1/4 cup milk  
1/2 teaspoon baking soda  
1 egg  
1/2 teaspoon salt

Combine flour, sugar, baking powder, baking soda, and salt. Add bananas, margarine, milk and egg. Pour into greased and floured 8" x 4" loaf pan. Cover pan with aluminum foil to prevent water from entering. Be sure the foil creates a tight seal around the pan. Fill Water Reservoir to Max level. Place pan in Steaming Bowl. Steam for 60 minutes.

# LIMITED WARRANTY

## What is Covered and For How Long

Congratulations on your recent purchase of a quality Sunbeam product. We are confident that our product will perform well and therefore warrant to you, as the original retail purchaser, for a period of 2 years from the date of original purchase, that your new product will be free of mechanical and electrical defects in material and workmanship.

## What Sunbeam Will Do & How to Get Service

If your product is covered during the warranty period, we will repair or replace your new product (at our option) without cost to you, which will be your exclusive remedy under this warranty. Simply send your product postage prepaid and insured, with proof of purchase and a short description of the problem directly to our factory service center at the following address:

SUNBEAM HOUSEHOLD PRODUCTS  
APPLIANCE SERVICE STATION  
117 Central Industrial Row  
Purvis, MS 39475

## What is Not Covered

Our warranty for your product will not cover normal wear of parts, damage resulting from negligent use or misuse of the product, use on improper voltage or current, use contrary to operating instructions, glass breakage (if applicable), or disassembly, repair, or alteration by any person other than an authorized service station. Any implied warranty of merchantability or fitness for a particular purpose on your product is limited to the duration of this written warranty. We shall not be liable for any incidental or consequential damages for breach of any express or implied warranty on your product.

## How Your State's Law May Apply

Some states do not allow limitations on how long an implied warranty lasts or the exclusion or limitation of incidental or consequential damages, so the above limitation may not apply to you. This warranty gives you specific legal rights, and you may also have other rights which vary from state to state.

California residents may call our toll free number to locate the nearest authorized service center at 1-800-597-5978.

*©1996 Sunbeam Corporation, or its affiliated companies, all rights reserved.  
Sunbeam Household Products Schaumburg, IL 60173*

P.N. #67531-2

1PA1B/534