

EXPRESS5800/System Rack

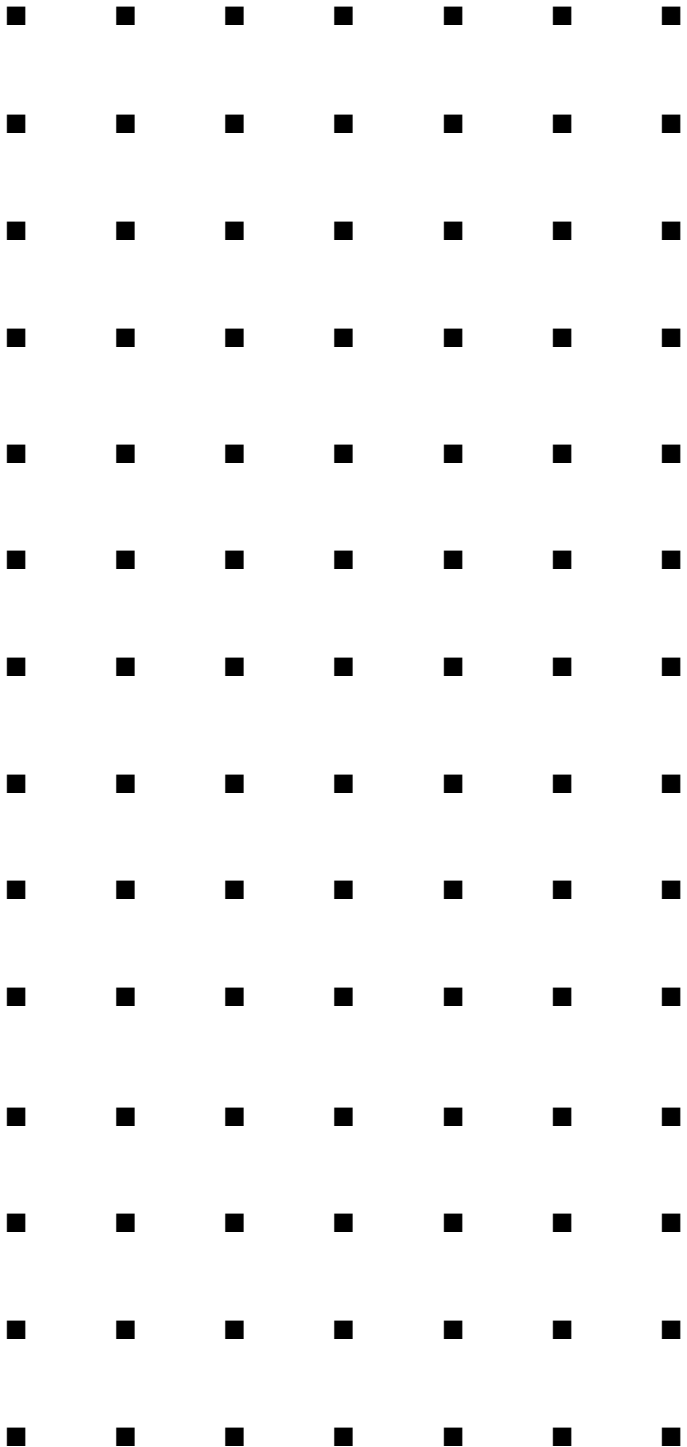

Service Guide

EXPRESS5800/System Rack

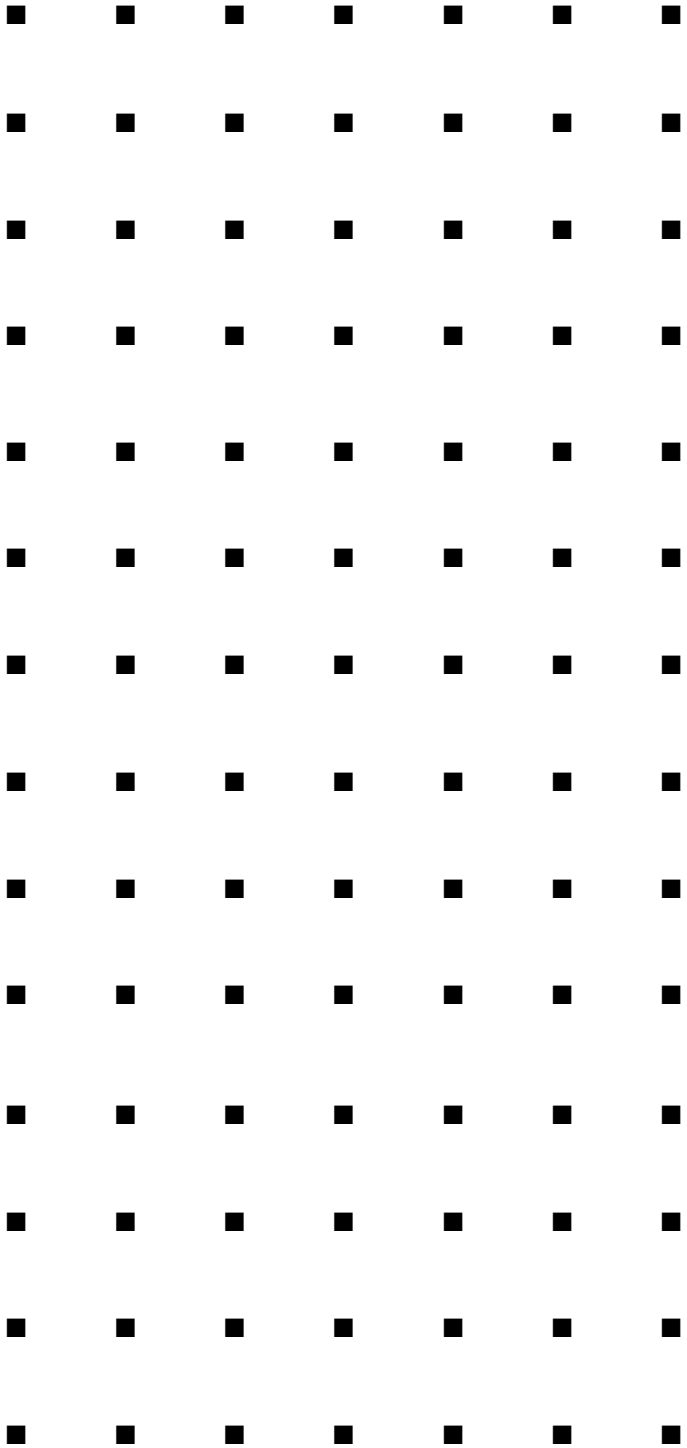

Service Guide

Proprietary Notice and Liability Disclaimer

The information disclosed in this document, including all designs and related materials, is the valuable property of NEC Computers Inc. and/or its licensors. NEC Computers Inc. and/or its licensors, as appropriate, reserve all patent, copyright and other proprietary rights to this document, including all design, manufacturing, reproduction, use, and sales rights thereto, except to the extent said rights are expressly granted to others.

The NEC Computers Inc. product(s) discussed in this document are warranted in accordance with the terms of the Warranty Statement accompanying each product. However, actual performance of each such product is dependent upon factors such as system configuration, customer data, and operator control. Since implementation by customers of each product may vary, the suitability of specific product configurations and applications must be determined by the customer and is not warranted by NEC Computers Inc.

To allow for design and specification improvements, the information in this document is subject to change at any time, without notice. Reproduction of this document or portions thereof without prior written approval of NEC Computers Inc. is prohibited.

Trademarks

PowerChute is registered trademark of American Power Conversion Corporation.

SmartSlot is a trademark of American Power Conversion Corporation.

All other product, brand, or trade names used in this publication are the trademarks or registered trademarks of their respective trademark owners.

PN: 456-01544-000

Copyright 2000
NEC Computers Inc.
15 Business Park Way
Sacramento, CA 95828
All Rights Reserved

Contents

Proprietary Notice

Using This Guide.....	v
Text Conventions.....	vi
Related Documents.....	vi
Safety Notices.....	vii
Safety Notices for Users Outside of the U.S.A. and Canada.....	vii
Care and Handling.....	viii

Planning Your Site 2-1

Equipment Location	2-2
Space Requirements	2-2
Environmental Conditions.....	2-4
Floor Construction.....	2-5
System Rack Placement.....	2-7
Air Conditioning.....	2-9
Cooling Capacity	2-9
Electrical Facilities	2-10
Uninterruptible Power Source (UPS).....	2-10
Power Distribution Unit (PDU).....	2-10
Grounding Requirements.....	2-11

Planning Your System Rack Configuration 3-1

Cabling Constraints	3-2
Cable Summary	3-2
RAID Cable Restrictions.....	3-3
Concentrator Cable Lengths.....	3-3
Vertical Spacing	3-3
Configuration Guidelines	3-6
Calculating Load and Determining UPS On-Battery Run Time	3-8

Installing the System Rack..... 4-1

Introduction	4-2
What You Need.....	4-2
Unpacking the System Rack and Components.....	4-3
Opening Front and Rear Doors	4-5
Removing Rack Side Panels.....	4-6
Leveling the System Rack	4-7
Installing Rack Frame Link Kits	4-8
What You Need.....	4-8
Attaching the Stabilizer to the System Rack	4-10

Installing Rack Components.....	5-1
Tools Required.....	5-3
Installing Rack Components.....	5-3
Recommendations and Warnings.....	5-4
Installing the UPS.....	5-4
Installing the Interface Expander Accessory.....	5-6
Installing the UPS.....	5-7
Connecting Your Master and Protected servers (BSUs).....	5-10
Installing a Power Distribution Unit.....	5-12
Installing a Keyboard Tray.....	5-13
Installing the Concentrator.....	5-14
Installing Blank Panels.....	5-17
Installing a Monitor Tray.....	5-18
Connecting the Console Monitor.....	5-19
Connecting Servers (BSUs) to the Concentrator.....	5-19

Illustrated Parts Breakdown	6-1
Field Replaceable Units.....	6-3
Options.....	6-5

Index

Using This Guide

This guide contains the information necessary to install the *Express5800 System Rack*. This guide is written for knowledgeable users, trained customer engineers, service center personnel, and dealers. *Please read these installation procedures in their entirety before starting.*

This guide contains the following information:

- Chapter 1, “Introduction” introduces you to the Express5800 System Rack models and describes the major system components that may be installed within the rack enclosure. See this chapter to familiarize yourself with your server rack.
- Chapter 2, “Planning Your Site” provides information about your Express5800 System Rack that you and your facility planners must have to properly prepare the site for rack installation.
- Chapter 3, “Planning Your System Rack Configuration” provides information on rack cabling, component space requirements, and component power consumption.
- Chapter 4, “Installing the System Rack ” provides information on unpacking and installing your system rack at your selected site.
- Chapter 5, “Installing Rack Components” contains helpful information for configuring and installing system components into the system rack.
- Chapter 6, “Illustrated Parts Breakdown” contains the exploded view and parts lists for the rack’s major assemblies. Part numbers are provided for optional hardware.

Text Conventions

This guide uses the following text conventions.

Warnings, cautions, and notes have the following meanings:

WARNING

Warnings alert you to situations that could result in serious personal injury or loss of life.

CAUTION

Cautions indicate situations that can damage the system hardware or software.

 **Note:** Notes give important information about the material being described.

- Names of keyboard keys are printed as they appear on the keyboard. For example, **Ctrl**, **Alt**, or **Enter**.
- Text or keystrokes that you enter appear as boldface type. For example, type **abc123** and press **ENTER**.
- File names are printed in uppercase letters. For example, **AUTOEXEC.BAT**.

Related Documents

In addition to this guide, the following system documentation is included with your server either as electronic files on EXPRESSBUILDER or as paper copy shipped with your server.

- ***Express5800 Server User's Guide***
Your Server User's Guide provides you with the information on installing your server into the system rack. Your server user's guide is located on the ExpressBuilder CDROM that came with your system.

Safety Notices



- **Caution:** To reduce the risk of electric shock which could cause personal injury, follow all safety notices. The symbols shown are used in your documentation and on your equipment to indicate safety hazards.
- **Warning:** Detachable power supply cords are intended to serve as the disconnect device.
- **Warning:** This equipment has a 3-wire, grounded power cord. To prevent electrical hazards, do not remove or defeat the ground prong on the power cord. Replace the power cord if it gets damaged. Contact your dealer for an exact replacement.
- **Warning:** The DC push-button on/off switch on the front panel of your server does not turn off the system AC power. Also, +5vdc is present on the system board whenever the AC power cord is connected between the system and an AC outlet. Before doing the procedures in this manual, make sure that your system is powered off and unplug the AC power cord from the back of the chassis. Failure to disconnect power before opening your system can result in personal injury and equipment damage.

All Servers and Peripherals installed inside a rack:

In the U.S.A. and Canada, the power cord must be a UL-listed detachable power cord (in Canada, CSA-certified), type ST or SJT, 16 AWG, 3-conductor, provided with a molded-on NEMA type 5-15 P plug cap at one end and a molded-on cord connector body at the other end. The cord length must not exceed 6.56 feet (2.0 meters).

Outside the U.S.A. and Canada, the plug must be rated for 250 VAC, 10 amp minimum, and must display an international agency approval marking. The cord must be suitable for use in the end-user country. Consult your dealer or the local electrical authorities if you are unsure of the type of power cord to use in your country. The voltage change occurs via a switch in the power supply.

- **Warning:** Under no circumstances should the user attempt to disassemble any power supply. A power supply has no user-replaceable parts. Inside the power supply are hazardous voltages that can cause serious personal injury. A defective power supply must be returned to your dealer.

Safety Notices for Users Outside of the U.S.A. and Canada

- **PELV (Protected Extra-Low Voltage) Integrity:** To ensure the extra-low voltage integrity of the equipment, connect only equipment with mains-protected electrically-compatible circuits to the external ports.

-
- **Remote Earths:** To prevent electrical shock, connect all local (individual office) computers and computer support equipment to the same electrical circuit of the building wiring. If you are unsure, check the building wiring to avoid remote earth conditions.
 - **Earth Bonding:** For safe operation, only connect the equipment to a building supply that is in accordance with current wiring regulations in your country.

Care and Handling

Use the following guidelines to properly handle and care for your system.

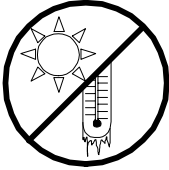

Protect the system from extremely low or high temperatures. Let the system warm (or cool) to room temperature before using it.



Keep the system away from magnetic forces.



Keep the system dry. Do not wash the system with a wet cloth or pour fluid into it.

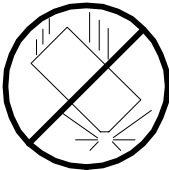

Protect the system from being bumped or dropped.



Check the system for condensation. If condensation exists, allow it to evaporate before powering on the system.



Keep the system away from dust, sand, and dirt.

1

Introduction

- Introduction
- System Rack Models
- Configurator Assistant
- 42U System Rack
- Multi-Bay System Rack

Introduction

The system rack is an attractive enclosure designed to store and protect your server components. The system rack allows you to integrate your server, monitor, and other components in one cabinet that may be installed in a limited amount of floor space in just about any location. Removable side walls and front and rear doors ensure easy access to all installed components, while a special locking system prevents unauthorized access.

System Rack Models

The system rack is available in three models: 42U, 36U and 27U. The only difference in the three models is the height of the rack. The size of each system rack is as follows:

- Model 42U – 2000mm (78.7in) H x 600mm (23.6in) W x 1000mm (39.4in) D.
- Model 36U – 1800mm (70.9in) H x 600mm (23.6in) W x 1000mm (39.4in) D.
- Model 27U – 1400mm (55.1in) H x 600mm (23.6in) W x 1000mm (39.4in) D.

This guide contains the information necessary to install the 42U System Rack. The installation process for the 36U and 27U is similar to the 42U model.

Express5800 Configuration Assistant

The Express5800 Configurator Assistant is a software program that provides detailed technical information on building server configurations. This program is especially helpful when configuring systems that will be installed into a system rack. Contact your sales representative for more information on the Express5800 Configuration Assistant.

42U System Rack

Figure 1-1 illustrates a typical 42U system rack enclosure, including the components that install into the rack. Table 1-1 lists and describes several system components installed in the system rack.

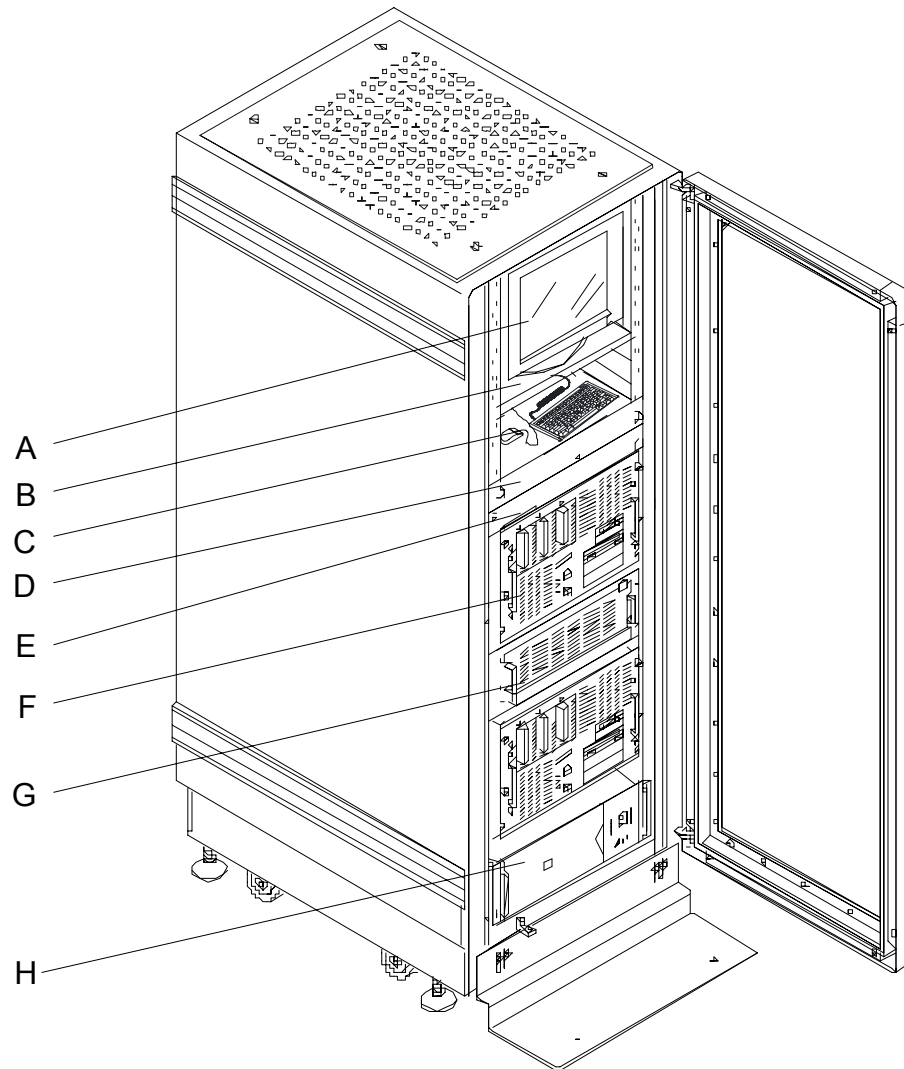

Figure 1-1. Typical 42U System Rack Enclosure

Table 1-1 lists the typical system rack components shown in Figure 1-1.

Table 1-1. Typical System Rack Components

Item	Component	Description
A	Monitor (LCD)	A monitor that serves as your standard output device.
B	Monitor Tray	Supports your monitor when installed in the rack.
C	Keyboard and Mouse	Standard input devices.
D	Keyboard and Mouse Tray	Supports your keyboard and mouse when installed in the rack.
E	8-Port Concentrator	Allows you to connect a single keyboard, mouse, and monitor to up to eight servers
F	Express5800 Server	Contains the Central Processing Unit (CPU), memory, disks, and other support hardware.
G	Disk Expansion Unit	Supports RAID configuration as well as disk expansion.
H	Power Distribution Unit (not shown)	If you are not using an Uninterruptible Power Source (UPS), AC power is distributed to system components through a Power Distribution Unit (PDU).
	High-performance, line-interactive, Uninterruptible Power Source (UPS)	Provides clean, reliable AC power to rack components to protect them from power blackouts, brownouts, swells, sags, surges, and interference the UPS can be used together with APC™ PowerChute® <i>plus</i> software to automate power protection services to up to three Servers.

Multi-Bay System Rack

System racks can be quickly and easily joined together to accommodate large server configurations as shown in Figure 1-2.

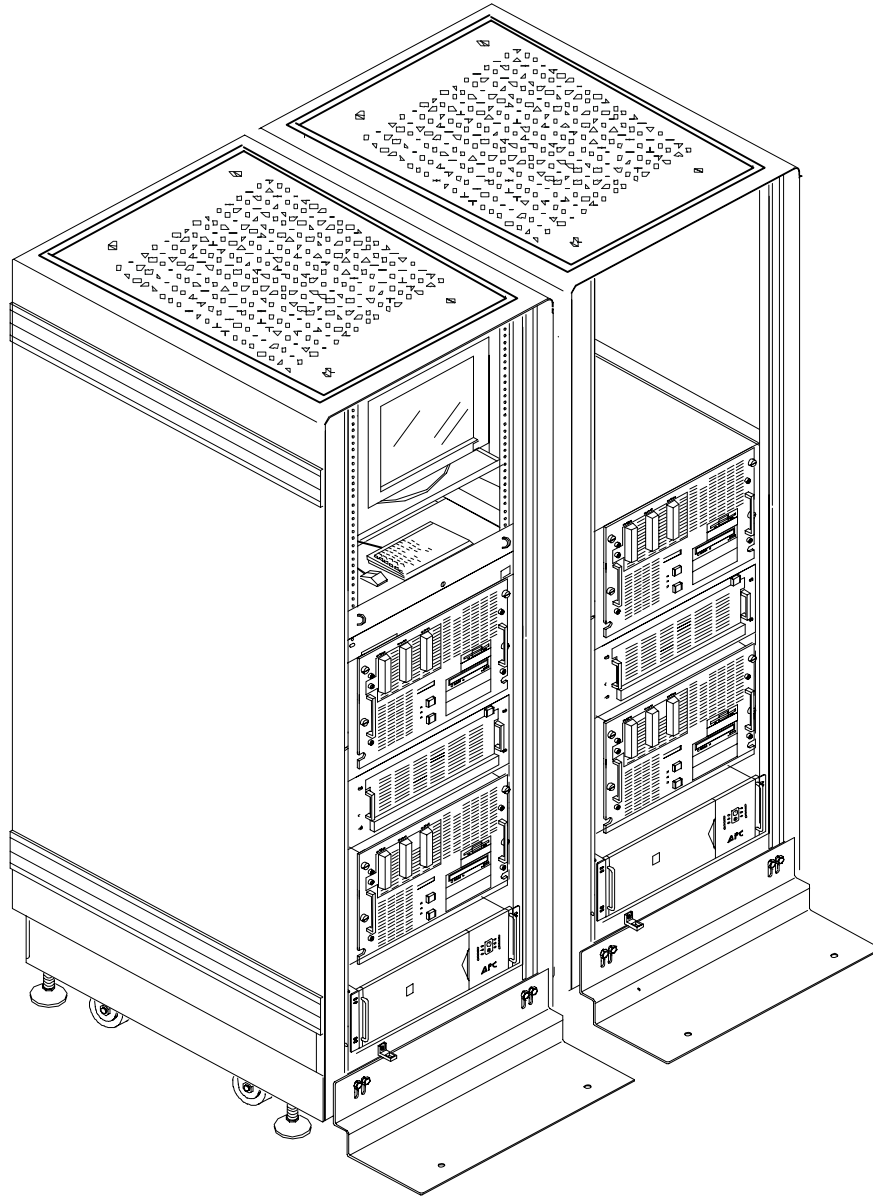

Figure 1-2. Multi-Bay System Rack

2

Planning Your Site

- Equipment Location
- System Rack Placement
- Air Conditioning
- Electrical Facilities
- Grounding Requirements

Equipment Location

When planning your facilities, the following guidelines must be considered:

- Does the allocated space allow for the proper installation of the equipment and the performance of operation and maintenance activities?
- Are the environmental conditions suitable for reliable operation?
- Is the construction of the floor appropriate for the weight of the equipment being installed?
- Will the air conditioning maintain adequate temperature and humidity conditions for the equipment being installed?
- Are the proper electrical facilities available and adequate for the equipment being installed?
- Will future expansion be necessary or possible?

To plan your facilities, you must know your system configuration.

Space Requirements

The system rack requires an area that can:

- Accommodate the height of the cabinet, which is 78.7 inches, (2 meters).
- Provide a clearance above the rack of 16 inches (400 mm).

The space requirements of the area surrounding a single cabinet are given in Figure 2-1. Note that the overall width should be increased by 23.4 inches for each additional cabinet that is required by your system.

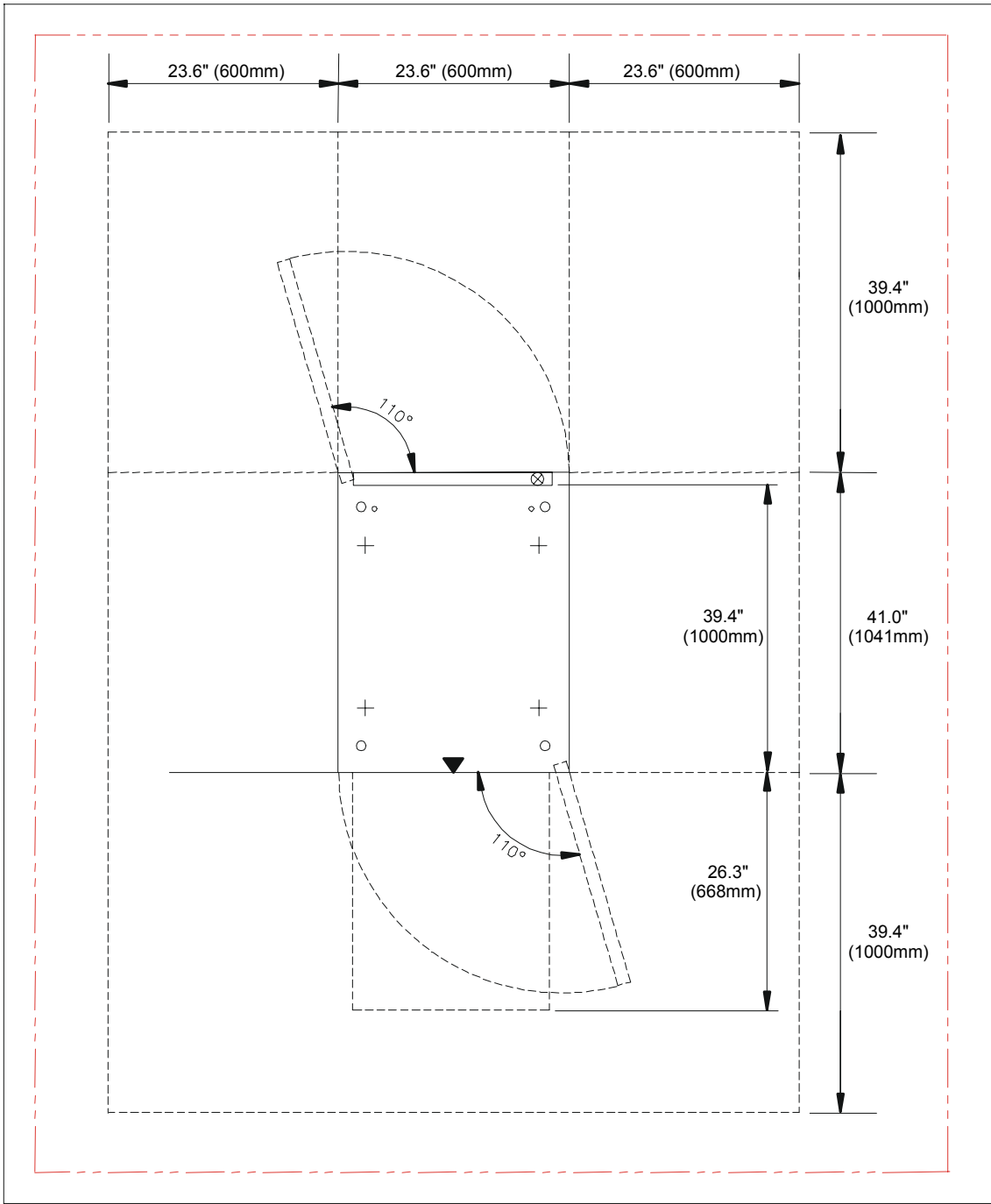

Figure 2-1. System Rack Space Requirements

Environmental Conditions

The location should be examined for the following environmental hazards:

- Dust - floating dust must be kept to no more than 0.3 mg/m³. Dust should be held to less than 0.15 mg/m³.
- Radio Frequency (RF) - Normally, there is no need to worry about the effect of radio frequency interference on computer operations. In areas where strong waves are generated or where a high-frequency device is installed on the same floor as the server, radio frequency can affect the functionality of the system.
- Magnetic Fields (MF) - Normally, there is no need to worry about the effect of magnetic fields on computer operations. If the server is installed near cables or transformers that permit the flow of high currents, functionality can be affected.

Floor Construction

Aspects of floor construction, such as load capacity and construction materials, must be considered when installing one or more rack systems.

 **Note:** The rack supports up to 551.2 lbs. (250 kg).

Use Table 2-1 to calculate the load that each rack of your system configuration places on the floor.

Table 2-1. Equipment Weight

Component	Weight (approx.)	Number Installed	Total
System Rack (42u)	253 lbs. (114.8Kg.)		
Express5800/120Ld	66.1 lbs. (30.0Kg.)		
Express5800/120Mc2	66.1 lbs. (30.0Kg.)		
Express5800/120Mc3	66.1 lbs. (30.0Kg.)		
Express5800/180Ra-7	165 lbs. (75.0Kg.)		
Express5800 ES1400	38.0 lbs. (17.2Kg.)		
Express5800 HX4500	207 lbs. (94.0Kg.)		
Express5800 HX4600	170 lbs. (77.0Kg.)		
Express5800 HV8600	165 lbs. (75.0Kg.)		
Express5800 LC1400	65.0 lbs. (29.3Kg.)		
Express5800 LS2400	38.0 lbs. (17.2Kg.)		
Express5800 MC2200	65.0 lbs. (29.3Kg.)		
Express5800 MC2400	65.0 lbs. (29.3Kg.)		
Express5800 MH4500	99.2 lbs. (45.0Kg.)		
3U Disk Expansion Unit (3UDEU)	44 lbs. (20.0Kg.)		
UPS	112.0 lbs. (50.8Kg.)		
PDU	9.0 lbs. (4.08Kg.)		
Monitor			
Concentrator	10 lbs. (4.5Kg.)		
Total			

If you do not know the load capacity of your flooring, consult your building manager or an architect.

In many instances the equipment is installed directly on the existing floor and interconnecting power cables are protected by cable covers.

In other instances, raised floors – that form a double floor – are used. Some advantages of raised floors are:

- Interconnecting cables can be routed under the raised floor.
- Floorboards can be easily removed to facilitate installation of cables.
- Adjustments can be made to air-conditioning ducts by cutting the floor as required.

The height of the raised floor must be no less than 14 inches (350 mm) — at least 16 inches (400 mm) is recommended. The base floor must be dustproof to prevent it from producing dust due to weathering and the floor covering material should produce little dust.

If a raised floor is used, continuity must be provided between the floorboards and support pillars. The insulation resistance between the floor surface and support pillars must be within the range of 10^6 to 10^{10} ohms.

To prevent the build-up of static, an antistatic treatment can be applied to the floor to keep its surface insulation resistance to at least 10^6 to 10^{10} ohms. Do not expose any metal directly to the floor.

When the surface insulation resistance is large, antistatic liquid can be applied or an antistatic mat can be used to eliminate any static charge.

If you are going to install your system on a carpet in an ordinary business office, use an antistatic carpet that produces little dust.

System Rack Placement

The system rack comes equipped with a front stabilizer that:

- steadies the rack when you extend equipment for servicing, and
- prevents creeping due to vibration.

The stabilizer is predrilled to allow you to secure the system rack to the floor.

 **Note:** If preparing the area prior to the arrival of the system, review the power cable restrictions given in “Electrical Facilities” before setting any stabilizer anchors.

Figure 2-2 gives the distance between anchoring holes when the stabilizer is attached to the system rack.

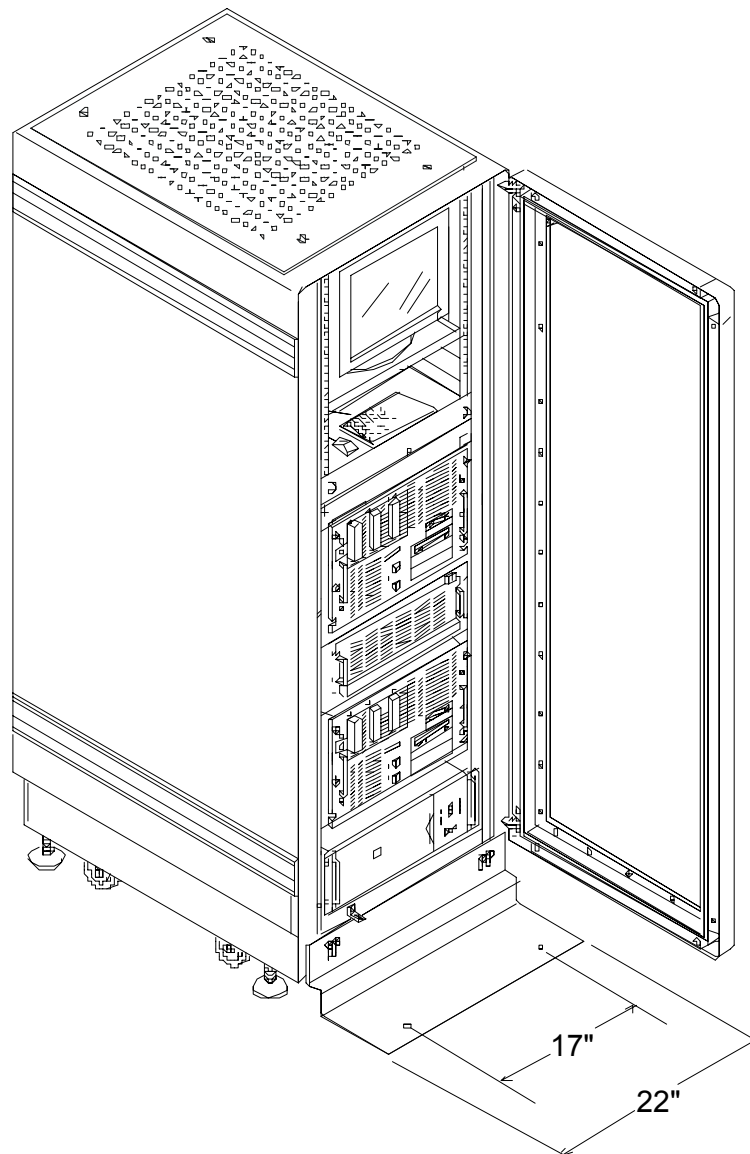

Figure 2-2. Distance Between Stabilizer Anchors

If the rack is installed on a concrete floor, you can bolt the rack to the floor using 3/8" concrete drop-in anchors and 1½"-16 bolts.

If you are installing your rack in an area with a raised floor, you can use concrete drop-in anchors and 3/8"-16 threaded rod with washers and nuts to secure the rack to the concrete beneath the raised floor. See Figure 2-3.

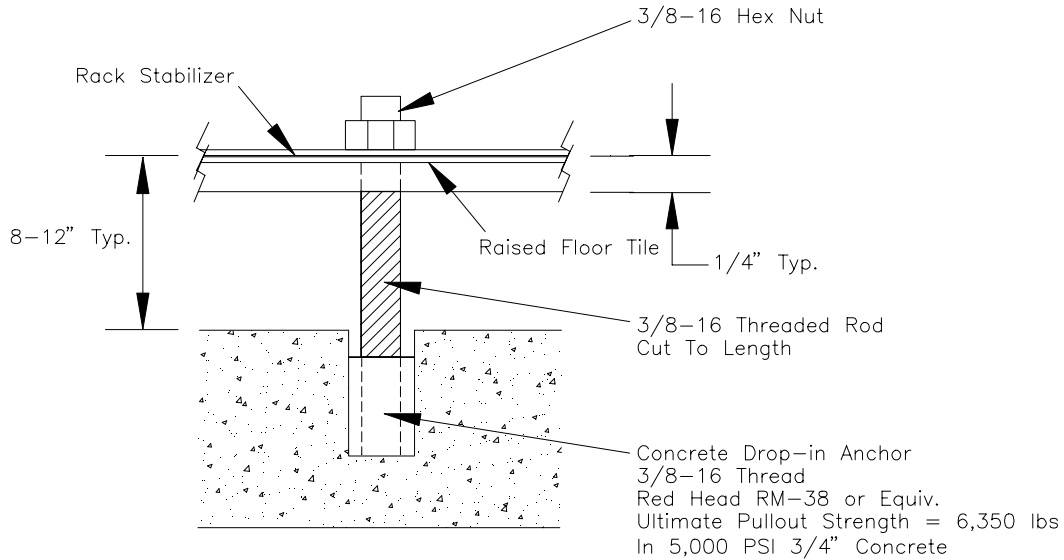

Figure 2-3. Raised Floor Installation

When you are installing your system on a wooden floor, you can use 1-3/4" 3/8" - 16 lag bolts as shown in Figure 2-4.

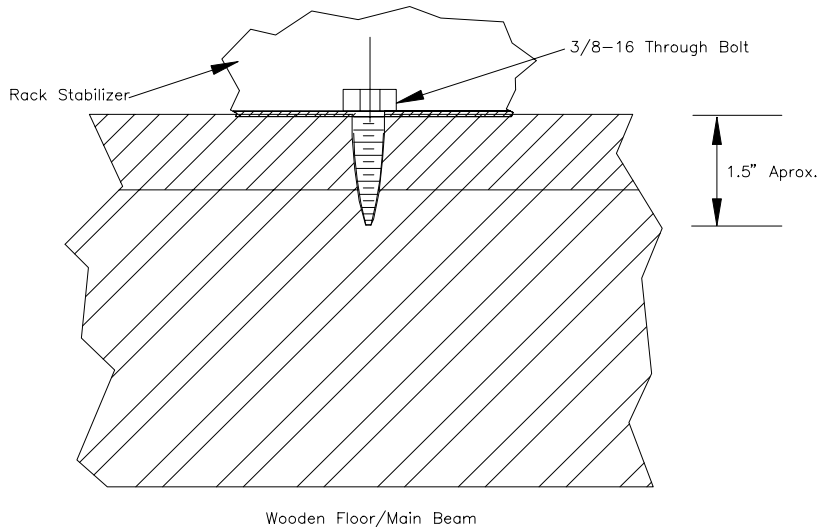

Figure 2-4. Wooden Floor Installation

Air Conditioning

A properly sized air conditioning system ensures stable and reliable operation of your servers by performing the following tasks:

- cooling the system
- preventing the generation of static charges
- preventing the formation of corrosion causing condensation within the system.

The system rack's temperature and humidity requirements are listed in Table 2-2.

Table 2-2. Temperature and Humidity Requirements

Item	Operating	Non-operating
Temperature	16 - 30°C	0 - 45°C
Relative humidity	40 - 70%	10 - 80%
	(non-condensing)	

Temperature and humidity should be measured 19.5 inches (50cm) from the system and 3.3 ft (1m) above the floor.

To satisfy temperature and humidity requirements, an air conditioner should be capable of heating, humidifying, and dehumidifying.

Heat is needed to precisely control temperature, increase computer room temperature in winter to the system's operating conditions, and to control humidity.

Humidifying is required to combat low humidity, which allows static charges to build-up.

If the system is operated in high-humidity conditions where condensation can occur, long term reliability may be affected.

Cooling Capacity

The cooling capacity of an air conditioner is determined by the following factors:

- 90% of the total calorific value of the system (allowing for expansion)
- calorific value from the ceiling, walls, and windows
- calorific value generated by personnel
- calorific value of lighting and additional machines
- humidity control effects.

The air conditioner's capacity must be larger than the sum of the above items. Use Table 2-3 to calculate calorific values – in BTUs.

Table 2-3. Calculating Total Calorific Values

Component	BTU/hr	Times Number Installed	Equals
Basic System Unit (typical)	2048		
Disk Expansion Unit (typical)	853		
UPS	375		
Monitor			
8-Port Concentrator	410		
Total			

Electrical Facilities

Depending on whether data availability is critical to your application or not, when you configured your system, you chose either an uninterruptible power source or a power distribution unit to supply rack components with AC power. The AC supply lines required by each of these devices is specified in the following paragraphs.

Uninterruptible Power Source (UPS)

If you have purchased one or more UPSs to supply AC power to your system and your system is located in North America, each UPS requires a 3-wire 30-Amp single-phase 120 Volt receptacle within six feet of the rear of the system rack. The UPS power cord comes equipped with a NEMA L5-30P power connector.

If your system is located in Europe, it requires a 240 Volt receptacle. The UPS power cord comes equipped with an IEC-320-C20 power connector.

Power Distribution Unit (PDU)

If you have purchased one or more PDUs, each PDU requires a 3-wire 30-Amp single-phase 120 Volt (240 Volt in Europe) receptacle within 10 feet of the rear of the system rack. The UPS power cord comes equipped with a NEMA L5-30P power connector (US models).

Grounding Requirements

The system rack must have a dedicated ground attached to the power distribution panel.

The ground wire must have an earth resistance of 100 ohms or less and depending on your local electrical code, a thickness of 38 mm² or more.

A grounding cable (12 gauge) that attaches the rack to frame (earth) ground must be used.

For safety reasons, ground connections are necessary for both power distribution systems and air conditioners.

If it happens that the ground to the server and the safety ground must be shared, branch it near the grounding electrode.

If a building structure such as a steel frame is used as a grounding electrode, use the main structural member closest to the building foundation.

3

Planning Your System Rack Configuration

- Cabling Constraints
- Cable Summary
- Vertical Spacing
- Configuration Guidelines
- Calculating Load and Determining UPS On-Battery Run Time

This chapter helps you configure your system and determine the number of racks you will need for your system.

When planning your configuration, you should consider the following guidelines:

- Does the layout violate any cable constraints?
- Is there enough rack space to accommodate all of the equipment that I have?

Cabling Constraints

When planning your system configuration you must consider the length of the cables that interconnect system components.

If a Server without any additional options meets all of your current computing needs, you will only have to concern yourself with connections to your keyboard, mouse, monitor and your LAN.

However, reviewing all the information in this section will allow you to configure your rack with future expansion in mind.

Cable Summary

Table 3-1 summarizes the cables that provide power and interconnect system components in the system rack. Additional information is provided in subsequent paragraphs and in option installation guides.

Table 3-1. Cable Summary

Cable	Purpose	Length
UPS Power Cable	Connects main AC power to your UPS.	6 feet (1.8 meters)
UPS Smart Cable(S)	These cables connect your UPS – via Smart-UPS® cables – to a master server running PowerChute® <i>plus</i> software and two <i>protected</i> BSUs. Working together, these options execute a controlled, orderly shutdown of all connected Servers.	6 feet (1.8 meters)
PDU Power Cable	If you did not purchase an UPS, this cable connects main AC power to your Power Distribution Unit (PDU).	15 feet (4.57 meters)
Keyboard, Mouse and Monitor Cables	Connects your keyboard, mouse, and monitor to your: BSU or concentrator, and each BSU keyboard, mouse, and monitor port to your concentrator.	7 or 12 feet (2.13 or 3.65 meters) depending on option chosen
Extension Cables	You can use 12-foot extension cables to extend connections from your 8-port concentrator to your keyboard, mouse, and monitor.	12 feet (3.65 meters)
SCSI Bus Cables	Connects RAID Controllers to DEUs	Vendor specific

RAID Cable Restrictions

RAID Host Adapters use a SCSI cable that connects each Disk Expansion Unit to its RAID Host Adapter in the Basic System Unit. Cables are available in 3.3-ft (1m) and 9.9-ft (3m) lengths.

Concentrator Cable Lengths

Cables for concentrator connections are available in 7-ft (2.1m) and 12-ft (3.7m) lengths.

To accommodate the installation of the keyboard, mouse, and monitor on an external desktop, a 12-ft (3.7m) extension cable that allows you to achieve an overall cable length of 19-ft (5.8m) or 23-ft (7.3m) is available.

NOTE: Extension cables should only be used between the keyboard, mouse, and monitor and the concentrator. They cannot be used between the concentrator and a BSU.

Vertical Spacing

Vertical measurements of rack components are given in Us. 1U is equal to 1.75 inches.

The total usable vertical space within a 42U rack is 42Us or 73.5 inches.

Figure 3-1 illustrates the arrangement of rack mounting holes and their relationship to a U.

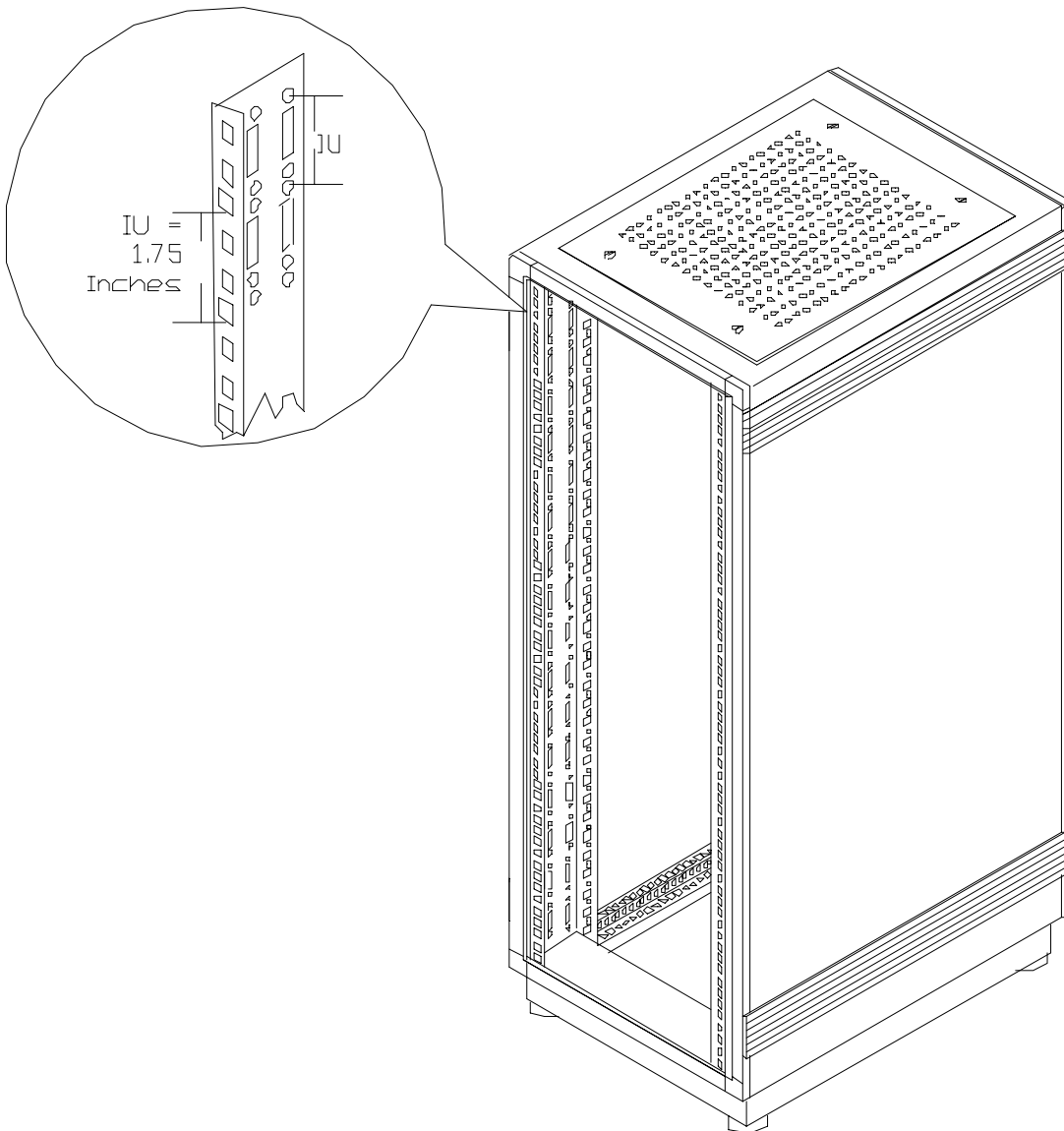

Figure 3-1. Mounting Hole Arrangement within a Rack

Table 3-2 lists the vertical space requirements for several Express5800 Server models and other rack components.

Table 3-2. Vertical Space Requirements

Rack Components	Space Requirements (Approximate)	
Express5800/120Ld	5U	8.75" (22.23cm)
Express5800/120Mc2	6U	10.5" (26.67cm)
Express5800/120Mc3	7U	12.25" (31.12cm)
Express5800/180Ra-7	7U	12.25" (31.12cm)
Express5800 ES1400	5U	8.75" (22.23cm)
Express5800 HX4500	14U	24.5" (62.23cm)
Express5800 HX4600	14U	24.5" (62.23cm)
Express5800 HV8600	17U	29.75" (75.57cm)
Express5800 LC1400	6U	10.5" (26.67cm)
Express5800 LS2400	5U	8.75" (22.23cm)
Express5800 MC2200	7U	10.5" (26.67cm)
Express5800 MC2400	6U	10.5" (26.67cm)
Express5800 MH4500	7U	12.25" (31.12cm)
Uninterruptible Power Source	3U	5.25" (13.12cm)
Power Distribution Unit*	2U	3.5" (8.75cm)
Disk Expansion Unit	3U	8.9" (22.2cm)
14" and 15" monitor with tray	10U	17.5" (43.75cm)
17" monitor with tray	11U	19.25" (27.5cm)
Keyboard and mouse with tray	2U	3.5" (8.75cm)
Concentrator	1U	1.75" (4.37cm)
1U blank panel	1U	1.75" (4.37cm)
2U blank panel	2U	3.5" (8.75cm)
3U blank panel	3U	5.25" (13.12cm)
6U blank panel	6U	8.72" (22.2cm)

*The Power Distribution Unit may be installed behind filler panels, the monitor tray or the keyboard tray.

Configuration Guidelines

When you configure a system, you should check your configuration to ensure compliance with the following guidelines:

1. To improve rack stability when servicing system components, mount heavier items such as servers in the bottom of the rack. If your rack is a stand-alone unit and the rack is more than 75% filled with components, consider installing the optional side stabilizer kit.
2. Each Model 42U Rack can contain up to 42U of components (1U is equal to 1.75 inches). Models 36U and 27U contain up to 36U and 27U of components, respectively.
3. The maximum Volt/Amps available from a single UPS is 3000VA (2250W).
4. The maximum Volt/Amps available from a single PDU is 2880VA.
5. The UPS should always be installed in the bottom of the rack.
6. The UPS and its associated PowerChute[®] *plus* software can only support three servers per UPS, without purchasing an additional interface expander module and additional cables.
7. If power distribution is provided by a PDU, the PDU is normally installed in the bottom of the rack. However, when rack space is at a premium, you can install the PDU directly behind the keyboard tray or the monitor tray.
8. The keyboard can be no more than 5U from the BSU unless a concentrator or extension cables are purchased.
9. If you are configuring the keyboard for use in a standing position, the recommended height is 18 to 20 U.

The System Rack Configuration Worksheet, Table 3-3, may be used to calculate the space requirements for components you plan on installing into the rack.

Table 3-3. System Rack Configuration Worksheet

Inches	Us	Component	Notes
73.5	42		
71.75	41		
70	40		
68.25	39		
66.5	38		
64.75	37		
63	36		
61.25	35		
59.5	34		
57.75	33		
56	32		
54.25	31		
52.5	30		
50.75	29		
49	28		
47.25	27		
45.5	26		
43.75	25		
42	24		
40.25	23		
38.5	22		
36.75	21		
35	20		
33.25	19		
31.5	18		
29.75	17		
28	16		
26.25	15		
24.5	14		
22.75	13		
21	12		
19.25	11		
17.5	10		
15.75	9		
14	8		
12.25	7		
10.5	6		
8.75	5		
7	4		
5.25	3		
3.5	2		
1.75	1		

Calculating Load and Determining UPS On-Battery Run Time

When you have chosen your configuration, you can use Table 3-4 and Table 3-5 to determine the load on a single power source and how much run time your configuration can expect from your UPS in the event your main AC service is interrupted.

To calculate the load and your on-battery run time, perform the following steps:

1. Determine the total load placed on each power source. The maximum load you can place on a single power source is:

Source	Maximum Load
UPS	3000VA (2250W)
PDU	2880VA

Table 3-4 provides Volt/Amp load values of system components and provides space to include other options.

You can calculate Volt/Amps by multiplying a component's voltage by its current requirement.

$$\text{— Voltage} * \text{Amps} = \text{VA}$$

Or if your component's power requirement is expressed in watts, multiply its wattage rating by 1.4.

$$\text{— Watts} * 1.4 = \text{VA}$$

Table 3-4. Determining the Load on a Single Power Source

Component	Voltage	Amps#	VA	Times the Number of Systems Installed	Load
Express5800/120Ld	120	4.6	552		
Express5800/120Mc2	120	9.0	1080		
Express5800/120Mc3	120	9.0	1080		
Express5800/180Ra-7*	120	5.1	612		
Express5800/180Ra-7**		8.5	1020		
Express5800 ES1400	120	6.0	720		
Express5800 HX4500	120	12.0	1440		
Express5800 HX4600	120	10.5	1260		
Express5800 HV8600	120	10.0	1200		
Express5800 LC1400	120	9.0	1080		
Express5800 LS2400	120	6.0	720		
Express5800 MC2200	120	9.0	1080		
Express5800 MC2400	120	9.0	1080		
Express5800 MH4500	120	10	1200		
3UDEU					
Port Concentrator	100	1	100		
Monitor					
Other					
Other					
Other					

* 4 Processors Installed
 ** 8 Processors Installed
 # Absolute Maximum Ratings

2. Add the individual loads you have listed in Table 3-4 to determine the total load on the power source.
3. To determine the run time your UPS will provide your system during a power failure, use Table 3-5 to find your total load and its associated run time in minutes.

Table 3-5. Total Load Versus On-Battery Run Time

Total Load	Run Time in Minutes	Total Load	Run Time in Minutes
50VA	297	600VA	54
75VA	258	700VA	44
100VA	228	800VA	36
150VA	183	900VA	31
200VA	152	1000VA	26
250VA	128	1200VA	20
300VA	110	1400VA	16
350VA	96	1600VA	13
400VA	84	2000VA	10
450VA	75	2200VA	8
500VA	67	2500VA	7
550VA	60	3000VA	5

4

Installing the System Rack

- Introduction
- Unpacking the System Rack and Components
- Leveling the System Rack
- Installing Rack Frame Link Kits
- Attaching the Stabilizer to the System Rack

Introduction

The steps required to prepare your rack are:

- Unpack and inventory your rack and its system components.
- Remove the doors and side panels from the rack to simplify the assembly of rack components.
- Position and level the rack(s).
- Install one or more rack frame link kits when assembling multi-rack systems.
- Attach the front stabilizer when your rack is in its permanent location.

What You Need

In addition to the materials shipped to you and standard hand tools, you will need:

- a level for leveling the rack and an adjustable wrench to lower and secure the leveling feet
- an adjustable wrench or ratchet set to attach the stabilizer to the base of the rack
- a #2 and #3 Phillips-head screwdriver to assemble rack-mounting hardware, and
- if you are assembling a multi-rack system, you will need a six foot step-ladder

WARNING

It is strongly recommended that two people be present when assembling the rack and installing system components.

Unpacking the System Rack and Components

Carefully unpack and verify the contents of each shipping carton. Be sure that you have all the hardware components and documentation.

In addition to this guide, you also received installation guides for options that were ordered. Your Server User's Guide contains information on installing your server into the rack.

 **Note:** It is important to save this documentation. It contains information that is valuable to both Field Service personnel and System Administrators. For example, the UPS Rack Mount Supplement describes how to replace and recycle the UPS battery.

If you find anything damaged or missing, contact your local service representative.

Your rack is shipped on a wooden pallet that includes an off-loading ramp. The rack is covered with corrugated cardboard and secured by plastic banding. See Figure 4-1

To remove the rack from the pallet, perform these steps:

1. Cut the banding and remove the corrugated cardboard.
2. Lower the off-loading ramp.

WARNING

The weight of an empty system rack is 253 lbs. If you are not using professional riggers to place the rack in its permanent location, do not attempt to remove the rack from the pallet without adequate assistance.

3. Roll the rack down the ramp to its permanent position.

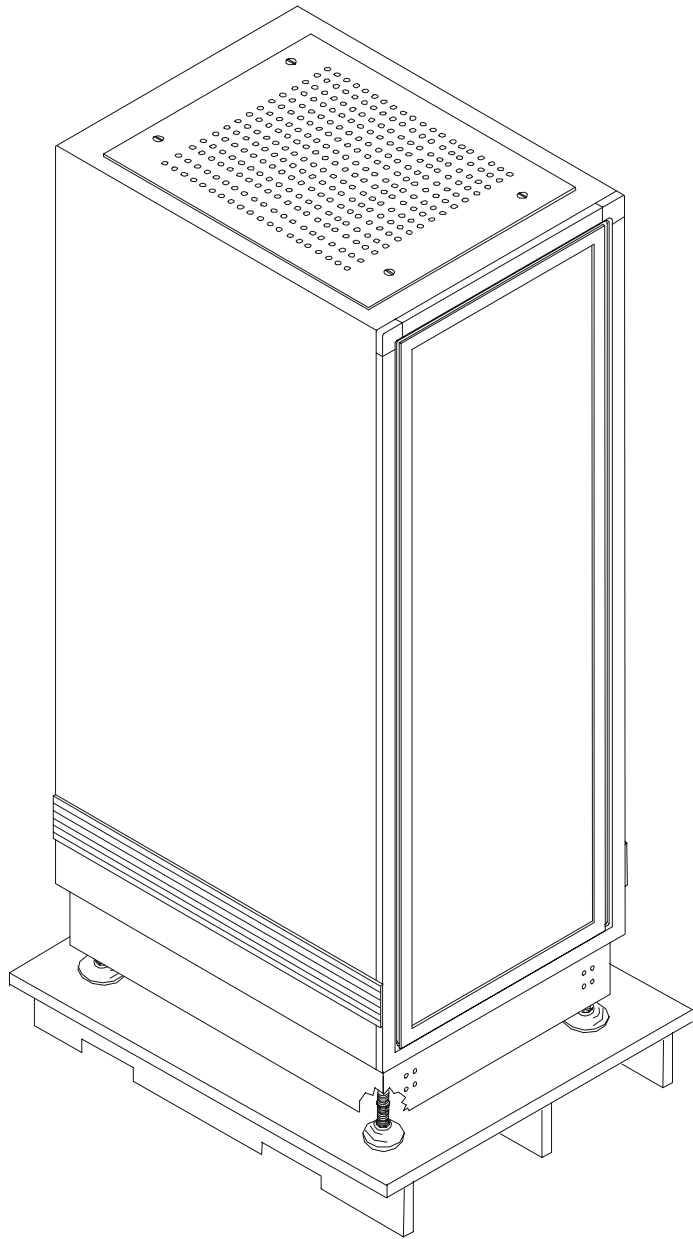

Figure 4-1. Rack Mounted on Shipping Pallet

Opening Front and Rear Doors

The front and rear doors of the rack are secured by handles with keylocks. To open the door:

1. Slide the handle release cover up to uncover the keylock and the handle release button. See Figure 4-2, A.
2. Unlock the lock, if necessary (Figure 4-2, B). Depress the handle release button (key hole button). The door handle extends when unlatched.
3. Rotate the handle (Figure 4-2, C) clockwise to open the door.

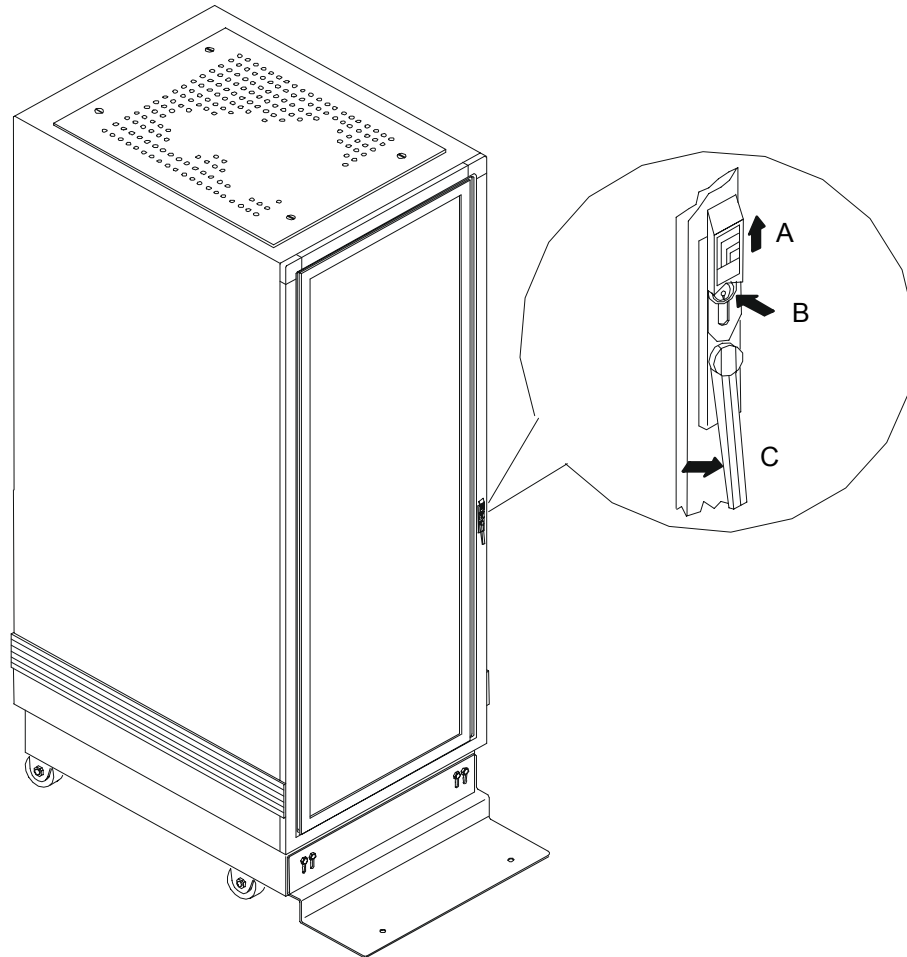

Figure 4-2. Accessing Door Handles

Inside the base of the rack, you will find a generous supply of mounting hardware – self-tapping screws, plated finish screws, black plastic washers and M6 cage-nuts.

You can simplify the removal of the rack from the pallet as well as the system assembly process by removing the front and rear doors and dismantling the side panels.

If you are installing a multi-rack system you must remove adjacent side panels of racks prior to installing the rack frame link kit.

Removing Rack Side Panels

To remove the rack side panels:

1. Remove the eight Phillips-head screws securing each side panel to the rack. See Figure 4-3.
2. Lift the side panels out and away from the rack.

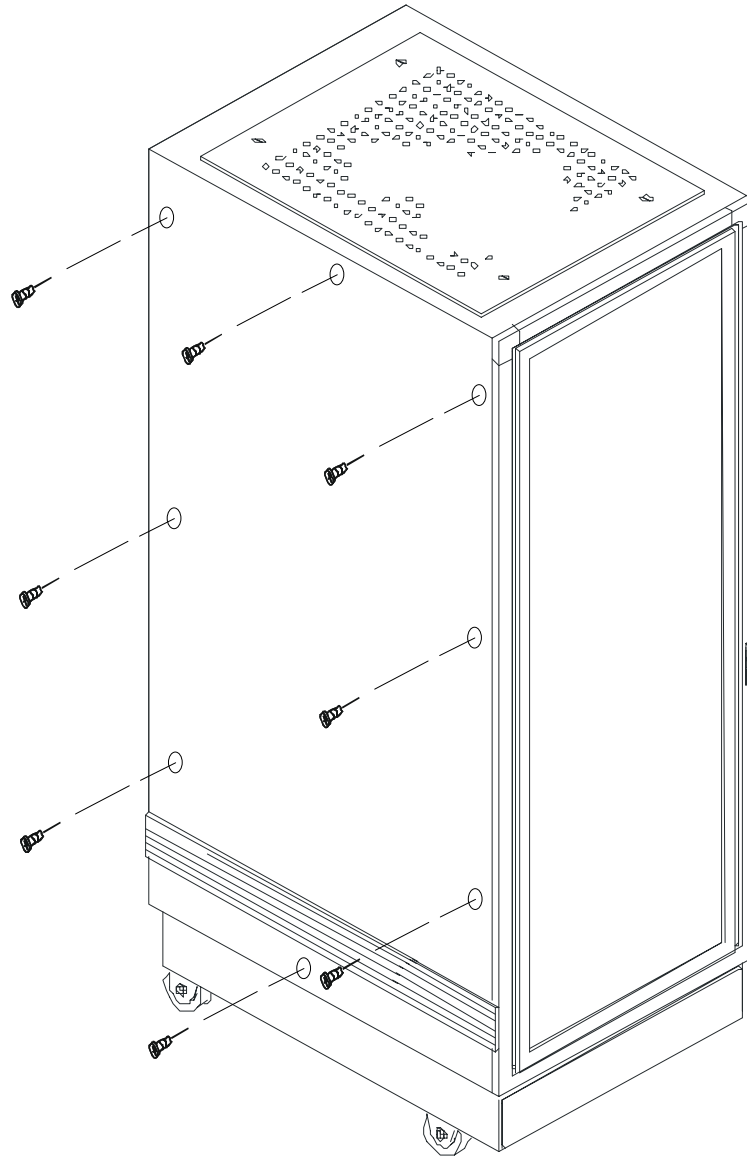

Figure 4-3. Removing the Side Panels.

Leveling the System Rack

When the rack is removed from the pallet and placed in its permanent location, you will extend the lifecycle of mechanical components by leveling the your rack.

Before leveling the rack, position the rack to conform with the space requirements specified in Chapter 2 and verify that your power receptacle is within six feet of the rear of your rack. To level the rack:

1. Lower the leveling foot located in each corner of the rack until they all make contact with the floor. See Figure 4-4

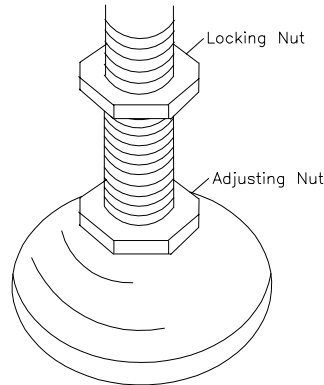

Figure 4-4. Leveling Foot Adjustment

2. Using your level, check the vertical and horizontal planes of the rack for level. Level your system rack by turning the adjusting nut on the top of each foot as needed.
3. Secure each leveling foot by tightening the lock nut up against the underside of the rack.

Installing Rack Frame Link Kits

This section describes how to assemble two or more racks into a multi-bayed system using the rack frame link kit. Figure 4-5 shows a linked multi-bayed system.

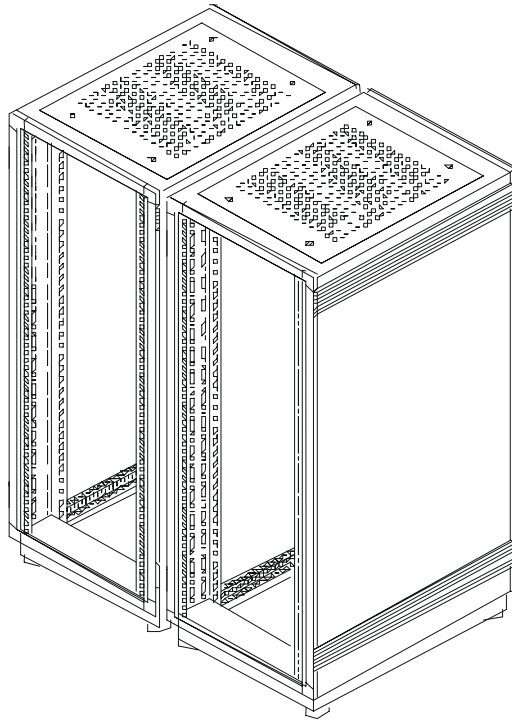

Figure 4-5. Multi-Bayed Rack System

What You Need

In addition to the Rack Frame Link shown in Figure 4-6, you will need:

- a #2 and #3 Phillips-head screwdriver to assemble the kit
- a six foot step-ladder

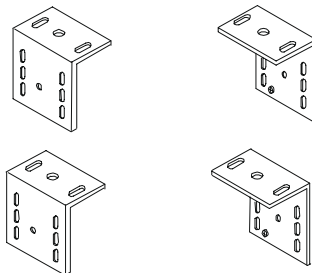

Figure 4-6. Rack Frame Link Kit

WARNING

It is strongly recommended that two people be present when assembling the rack and installing system components.

To install the rack frame link kit:

1. Position the two rack cabinets next to each other as shown in Figure 4-7. Ensure the front of each rack is facing in the same direction.
2. Position a link angle bracket in the upper front corner of the left cabinet and secure it to the cabinet with two Phillips-head screws. See Figure 4-7.
3. Secure the remaining three link angle brackets to the other three corners of the left cabinet in the same manner.
4. Move the right cabinet adjacent to the left cabinet so that the link angle brackets secured to the left cabinet protrude into the corners of the right cabinet.
5. Secure the cabinets together with the Phillips-head screws supplied.

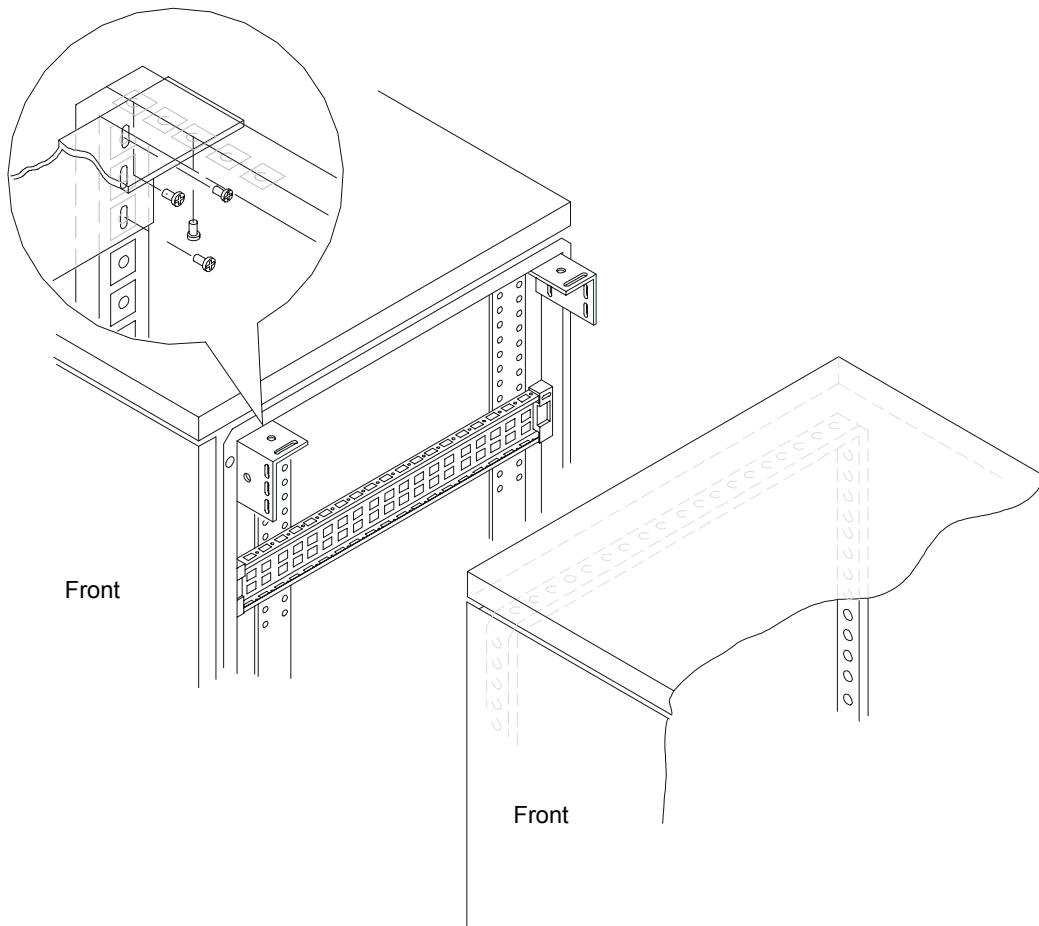

Figure 4-7. Rack Frame Link Kit Installation

Attaching the Stabilizer to the System Rack

After positioning and leveling the system rack, attach the stabilizer to the front of your rack using an adjustable wrench or ratchet. See Figure 4-8.

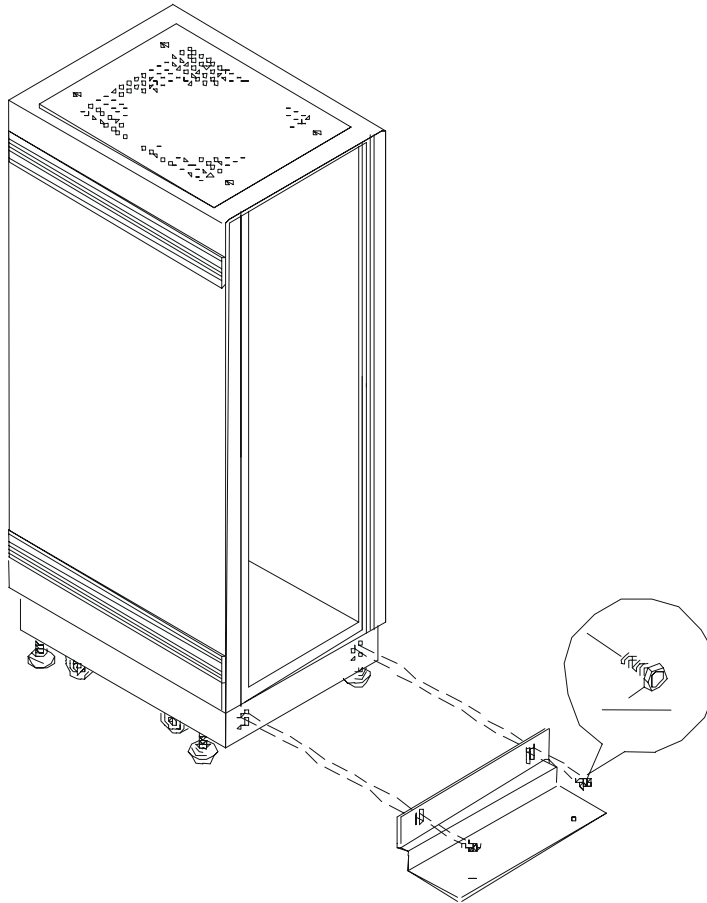

Figure 4-8. Attaching the Front Stabilizers

WARNING

To ensure the stability of the rack during component installation, you must attach the front stabilizer prior to installing any system components.

If you are securing the rack to the floor, do so now. See Chapter 2 – “Securing the System Rack” for details.

5

Installing Rack Components

- Tools Required
- Installing Rack Components
- Installing the UPS
- Installing a Power Distribution Unit
- Installing a Keyboard Tray
- Installing the Concentrator
- Installing Blank Panels
- Installing a Monitor Tray
- Connecting the Console Monitor
- Connecting Servers to the Concentrator
- Installing Other System Rack Components

This chapter describes the installation of individual system components in a system rack. For the purpose of explanation, installation instructions are presented in the order required to install a typical configuration. See Table 5-1

Table 5-1. Typical Configuration

Inch	Us	System Rack	Notes
73.5	42		
71.75	41		
70	40		
68.25	39		11U of space remains to
66.5	38		accommodate up to a
64.75	37		17 inch monitor.
63	36		
61.25	35		
59.5	34		
57.75	33		
56	32		
54.25	31	1U monitor tray	
52.5	30		
50.75	29		
49	28	6U blank panel	
47.25	27		
45.5	26		
43.75	25		
42	24		
40.25	23	3U blank panel	
38.5	22		
36.75	21	1U port concentrator	
35	20	2U keyboard tray	
33.25	19		
31.5	18	2U blank panel	
29.75	17		
28	16		
26.25	15	3U blank panel	
24.5	14		
22.75	13		
21	12		
19.25	11	7U Basic System Unit	
17.5	10		
15.75	9		
14	8		
12.25	7		
10.5	6		
8.75	5	3U Disk Expansion Unit	
7	4		
5.25	3	3U Uninterruptible Power Source	
3.5	2		
1.75	1		

The exception to this process is the Power Distribution Unit (PDU), which is discussed as an alternative to the UPS that it immediately follows.

Tools Required

In addition to the materials shipped to you and standard hand tools, you will need:

- #2 and #3 Phillips-head screwdrivers to assemble rack-mounting hardware, and
- a 3mm Allen wrench and 4mm nut driver to tighten the monitor tray mounting posts

Installing Rack Components

In general, the installation of a rack unit requires the:

- Installation of cage-nuts at the rail locations used to secure the front bezel of a unit to the rack. Figure 5-1 shows a typical installation of the cage-nuts.
- Installation of mounting hardware, usually chassis slide rails or L-brackets
- Installation of the unit into its mounting hardware and then securing the unit to the rack
- Connection of AC power and data cables

 **Note:** If using this document for an upgrade of existing equipment, be sure that all external cables connected to the system unit are disconnected before sliding the unit out from the rack.

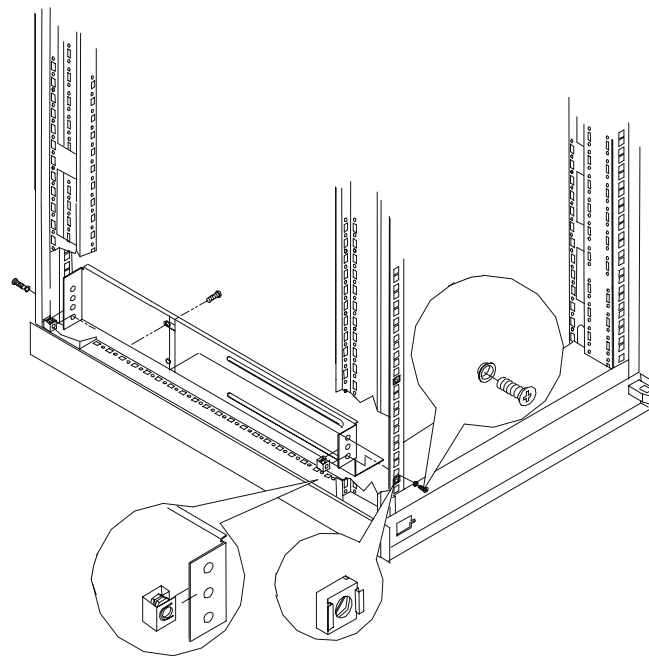

Figure 5-1. Installing Rack Hardware

Recommendations and Warnings

Please adhere to the following recommendations and warnings when installing your rack system.

- To improve rack stability when servicing system components, mount heavier items such as a UPS or server in the bottom of the rack.
- If your rack is a stand-alone unit and the rack is more than 75% filled with components, consider installing the optional side stabilizer kit. Refer to Table 6-2 for the part number of the side stabilization kit.

WARNING

Two people are required when assembling the rack and installing system components into the rack.

Installing the UPS

This section describes how to install an Uninterruptible Power Source (UPS) into a system rack. See Figure 5-2.

The Uninterruptible Power Source (UPS) is a high-performance, line-interactive supply that provides clean, reliable AC power to system rack components to protect them from power blackouts, brownouts, swells, sags, surges, and interference.

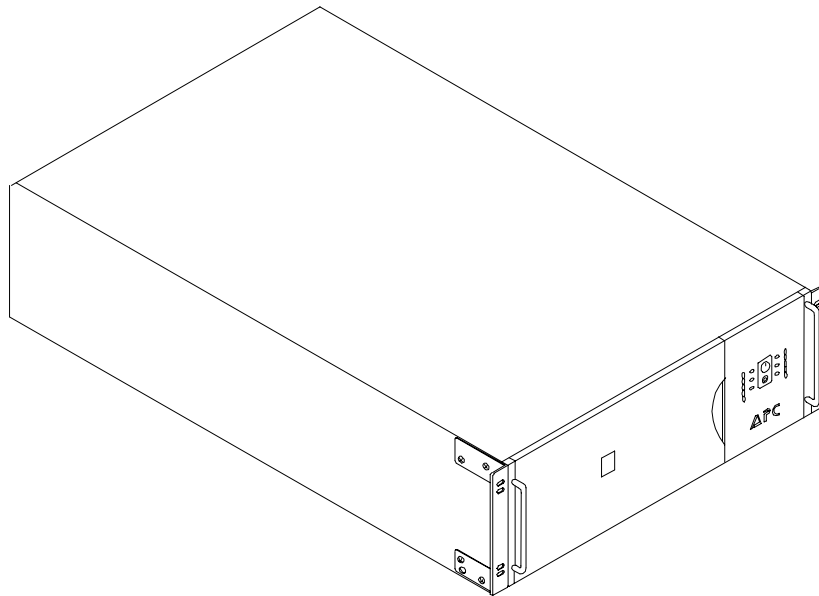

Figure 5-2. Uninterruptible Power Source

Your UPS provides diagnostic and management features that include:

- Scheduled server shutdowns
- Interactive and scheduled battery testing
- Detailed power quality logging
- Real-time graphical displays showing
 - UPS load
 - utility line voltage
 - battery voltage
 - run time remaining

These features are implemented for a single server (BSU) by connecting the server's serial port to the UPS computer interface port and installing the PowerChute[®] *plus* software on the server (*BSU*).

The System Administrator uses the PowerChute[®] *plus* graphical user interface to set up the operational parameters required by site policies.

Additional servers installed in the same rack may be connected to the UPS when:

- You install the Smart Slot[™] UPS Interface Expander Unit into the UPS.
- You connect the protected server's serial port to the expander accessory unit using the simple signaling cables received with the Expander Unit Interface Kit.
- The System Administrator installs PowerChute[®] Plus software on each protected server and uses the graphical user interface to set up the operational parameters required by site policies.

Figure 5-8 illustrates the connections between the UPS, master server, and additional protected servers.

This procedure summarizes the installation of a UPS in a system rack. For detailed information about:

UPS	Refer to:
Features	Uninterruptible Power Source User's Manual
UPS Interface Expander Unit	Interface Expander Unit User's Manual
Installation	This Rack User's Manual
Expander Unit Interface Kit	Interface Kit User's Manual
PowerChute [®] <i>plus</i>	PowerChute [®] <i>plus</i> User's Guide

Installing the Interface Expander Accessory

You can install the interface expander unit prior to installing the UPS in the rack.

 **Note:** Perform this procedure if you are connecting more than one server (BSU) to the UPS.

To install the interface expander, perform the following steps:

1. Using a #2 Phillips-head screwdriver, remove the two screws securing the top accessory slot cover on the back panel of the UPS. See Figure 5-3. Retain the screws for future use.

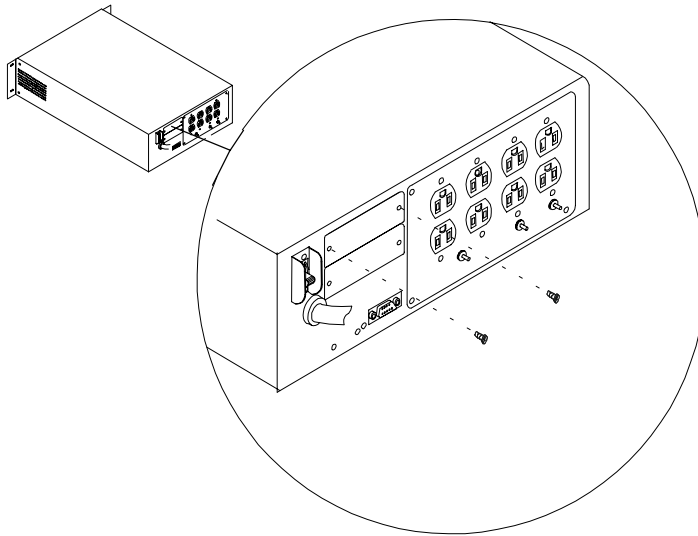

Figure 5-3. Accessory Slot Location

2. Position the interface expander unit to fit in the UPS accessory slot as shown in Figure 5-4.

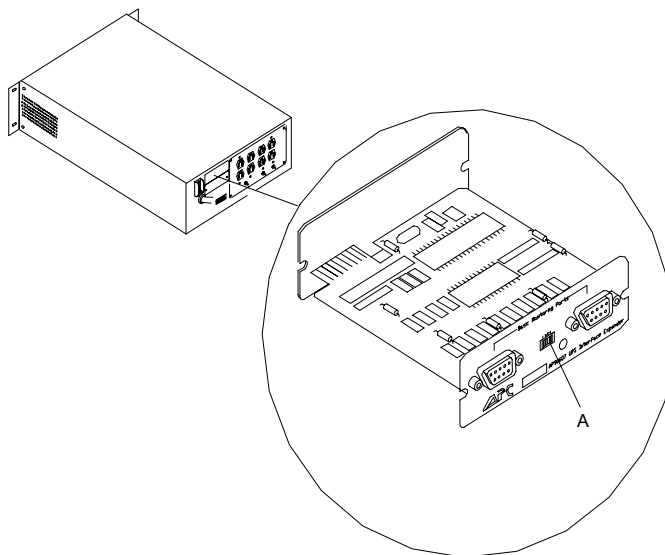



Figure 5-4. Installing the Interface Expander

-
3. Slide the interface expander all the way into the slot, until the end plate is flush with the back panel of the UPS.
 4. Secure the accessory with the two screws removed in Step 1.
 5. If the installation does not include PowerChute® *plus* software, review the following topics with the System Administrator:
 - Configuration switch settings (Figure 5-4, A); see Section 7 of the UPS Interface Expander Accessory document, and
 - Status Light; see Section 10 of the UPS Interface Expander Accessory document.

 **Note:** When installed and configured, PowerChute® *plus* software overrides UPS configuration switch settings.

Installing the UPS

To install the UPS:

1. Install the four M6 cage-nuts that will secure the front of the UPS to the rack. Position the cage-nuts to align with the screw holes in the front bezel of the UPS. Use the template provided with the UPS.

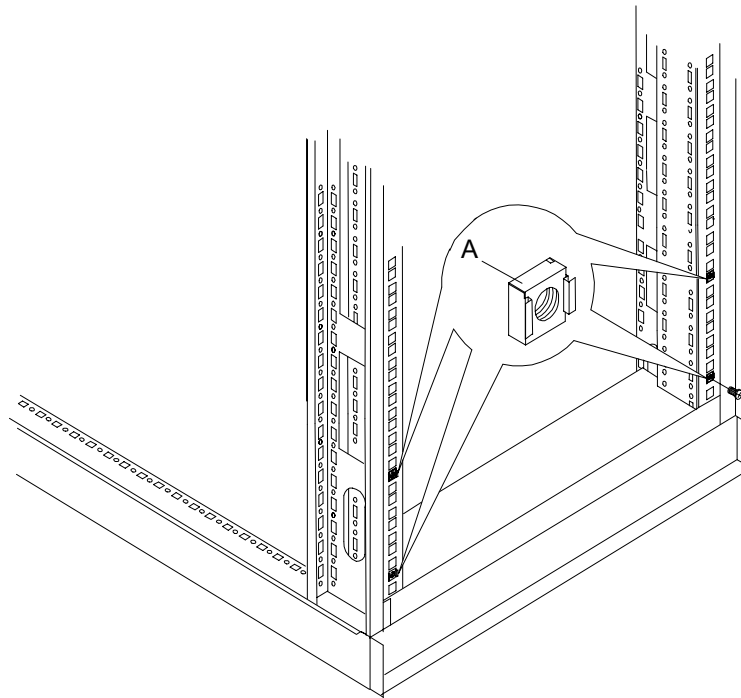

Figure 5-5. Installing M6 Cage-Nuts

2. As illustrated in Figure 5-6, assemble the L-channel support brackets (A) and adjust the rails to span the depth of the rack.

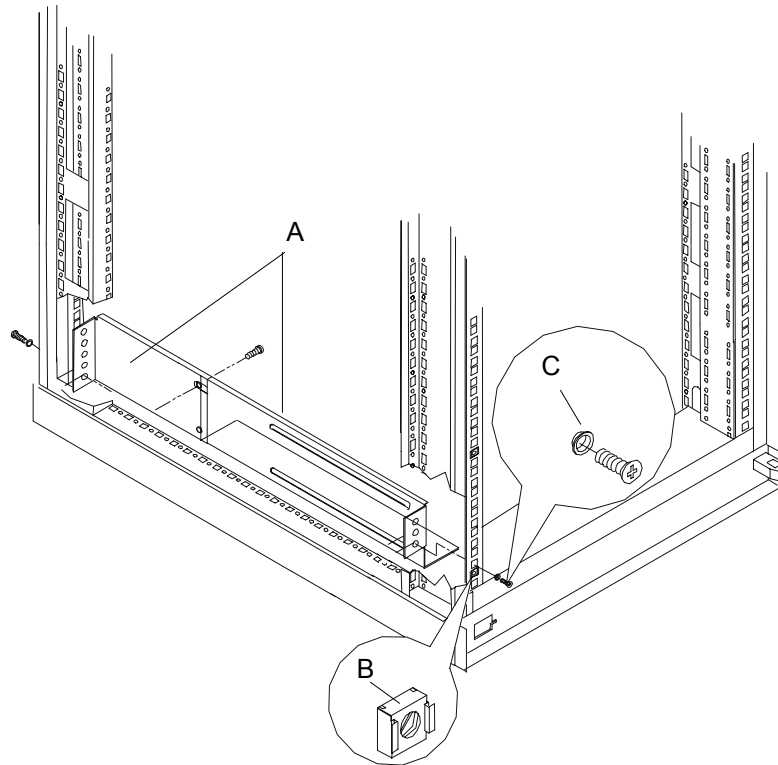



Figure 5-6. Mounting UPS L-Channel Supports

3. Secure the brackets to the rails with the washers and flat-head screws (Figure 5-6, C) provided with the UPS.

 **Note:** The ear of an L-channel support has two mounting screw holes.

4. With the aid of another person, slide the UPS onto the L-channel supports and secure the UPS to the rack using the black plastic washers and plated finish screws provided with the rack.
5. Connect the UPS battery. Refer to the documentation that you received with the UPS for details.
6. Connect the UPS power cable to the AC power source. Refer the documentation provided with your UPS.
7. Switch on the UPS to execute a self-test before connecting any system components. See the Installation and Operation section of the “Uninterruptible Power Source User’s Manual”.
8. Check the Site Wiring Fault indicator. See Figure 5-7, C.

— If the indicator is illuminated, have a qualified electrician correct the building wiring. Faults can be caused by a missing ground, a hot and neutral polarity reversal, or an overloaded neutral circuit.

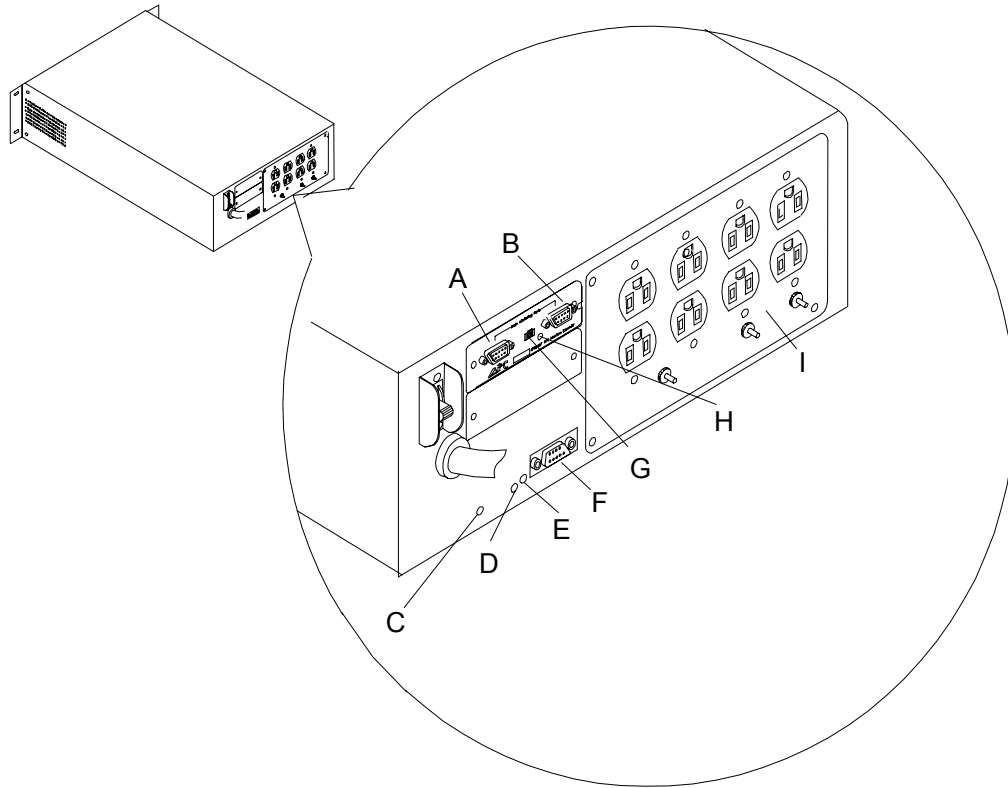

- A. Basic Monitoring Port 1
- B. Basic Monitoring Port 2
- C. Site Wiring Fault Indicator
- D. Configuration Button
- E. Configuration LED
- F. Smart Monitoring Port for Master Server
- G. Configuration Switches
- H. Status Light
- I. Output Power Receptacles

Figure 5-7. Location of UPS Rear Panel Components

9. If you do not have a wiring fault, connect the ground lead of any transient voltage surge-suppression (TVSS) devices such as telephone and network line protectors. The TVSS connector provides grounding through the UPS' power cord ground conductor. This provides protection from damage from surges transmitted via network and phone cables.

Connecting Your Master and Protected servers (BSUs)

To connect your master and protected servers, perform the following steps:

1. As the installation progresses, connect the power cables from individual system components to the receptacles of the AC distribution panel located in the rear of the UPS. See Figure 5-8, F.
2. Designate one server to be your master server and connect the black smart signaling cable (Figure 5-8, C) received with the PowerChute[®] *plus* option, between a server serial port and the UPS smart signaling port.
3. On your configuration worksheet, note which server and serial port are connected as master. The System Administrator will need this information when loading and configuring PowerChute[®] *plus* software.
4. Using the gray simple signaling cable (Figure 5-8, A) from the interface kit, connect the server(s) being protected to the basic monitoring ports 1 and 2 of the interface expander accessory.
5. On your configuration worksheet, identify each protected server and its connection to the basic monitoring ports.
6. Deliver the configuration worksheet to the System Administrator. This information is required to properly configure PowerChute[®] *plus* software.

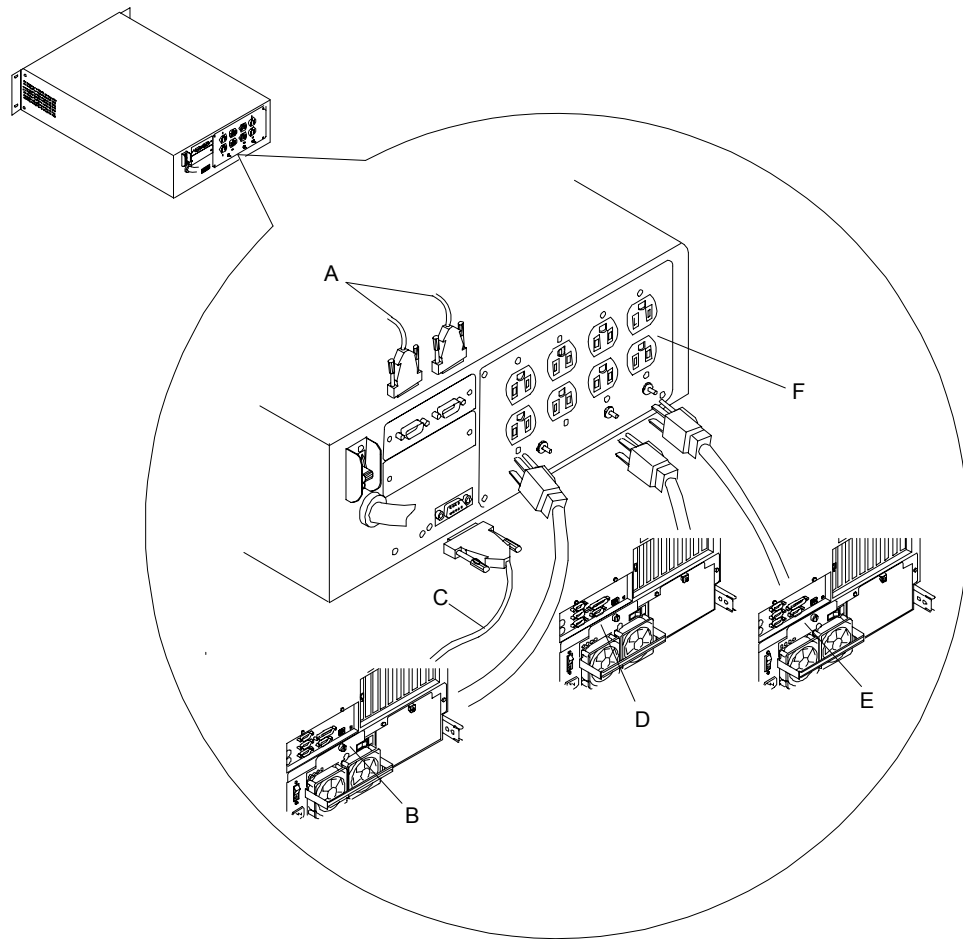

- A. Simple Signal Cables (Gray Cables)
- B. Master Server (BSU)
- C. Smart Cable (Black Cable)
- D. Protected Server (BSU) 1
- E. Protected Server (BSU) 2
- F. AC Distribution Panel

Figure 5-8. Connecting Your Servers to the UPS

Installing a Power Distribution Unit

If you are not using an Uninterruptible Power Source (UPS), AC power is distributed to system components through a Power Distribution Unit (PDU). See Figure 5-9.

The PDU comes equipped with a 15-foot power cord and can be installed either in the bottom of the rack, or when rack space is at a premium, directly behind your keyboard tray. See your configuration work sheet to determine the location chosen for your PDU.

 **Note:** When you install a PDU behind a keyboard tray, the remaining workspace will be restricted. Therefore, it is recommended that keyboard, mouse, monitor, and connections to any port concentrator are completed before you install a PDU behind a keyboard tray.

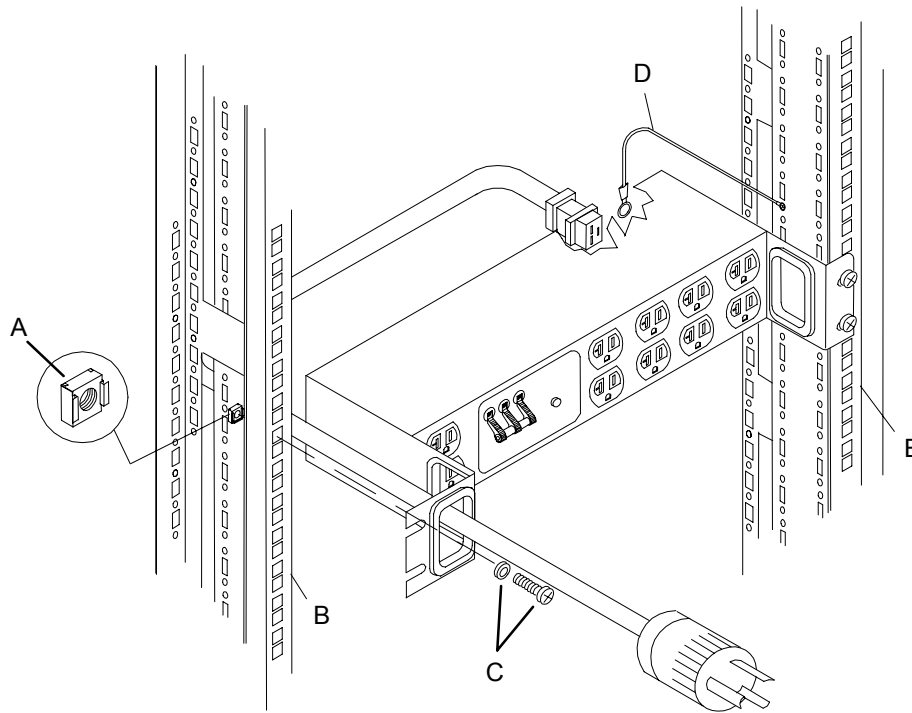

- A. Cage-nut
- B. Rack Vertical Rail, Left Rear
- C. PDU Mounting Screw and Washer
- D. Green Ground Strap
- E. Rack Vertical Rail, Right Rear

Figure 5-9. Installing the Power Distribution Unit

To install your PDU:

1. Place two cage-nuts (Figure 5-9,A) on each rail at the location you have chosen to mount your PDU.
2. Secure the PDU to the rails using the black plastic washers and plated-finish screws (Figure 5-9, C).
3. Using a self-tapping screw, connect the green ground strap (Figure 5-9, D) to the rail.
4. Connect the AC power cord to the PDU.
5. If you install your PDU behind the keyboard tray, midway up the rack rather than in the bottom of the rack, dress and secure the power cable to provide some strain relief to the cable connection.

Installing a Keyboard Tray

 **Note:** Some keyboard tray models are front-mount only, and are secured only to the front rails. Your keyboard tray may not look like the model pictured in Figure 5-10.

This section describes how to install a keyboard tray into a system rack.

The keyboard tray provides you with:

- a convenient work surface that stores your keyboard and mouse
- a secured compact enclosure when your keyboard and mouse are not in use

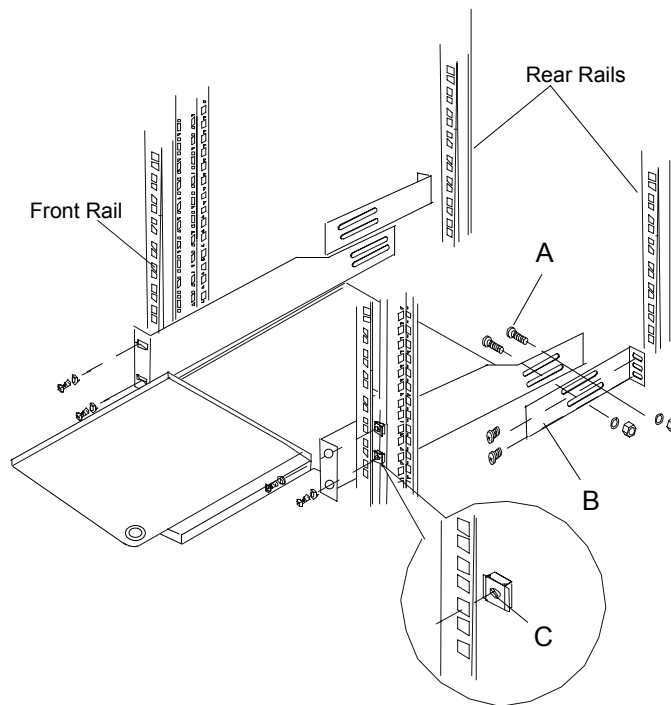

Figure 5-10. Securing the Keyboard Tray

As shown in Figure 5-10, the keyboard tray is secured to the front and rear rails of the system rack in with cage-nuts, black plastic washers, and plated finish screws that came with the system rack.

To install your keyboard tray:

1. Using the longer set of screws (Figure 5-10, A) received with the keyboard tray, attach the two halves of each side rail together. The rear rail (Figure 5-10, B) should be assembled to the outside, or closest to the rack rails.
2. Adjust the length of the keyboard tray rails to fit between the front and rear vertical posts in the system rack.
3. Place two cage-nuts (Figure 5-10, C) on each front and rear rail at the locations you have chosen to mount your keyboard tray.
4. Secure the keyboard tray to the rails using the black plastic washers and plated-finish screws.

Installing the Concentrator

This section describes how to install a concentrator into a system rack.

A concentrator allows you to use a single keyboard, mouse, and video display as a console monitor for up to eight servers (BSUs).

You can install your console monitor either in your system rack or externally on a desktop. Cables for the concentrator connections are available in 7-ft and 12-ft lengths.

A 12-ft extension cable allows you to achieve an overall cable length of 19-ft or 24-ft in order to install the keyboard, mouse, and monitor on an external desktop.

 **Note:** Extension cables should only be used between the keyboard, mouse, monitor and the concentrator.

To install your concentrator:

3. Using the longer set of screws (Figure 5-11, C) received with the concentrator, attach the two halves of the side rail together. The rear rail (Figure 5-11, B) should be assembled to the outside, or closest to the rack rails.

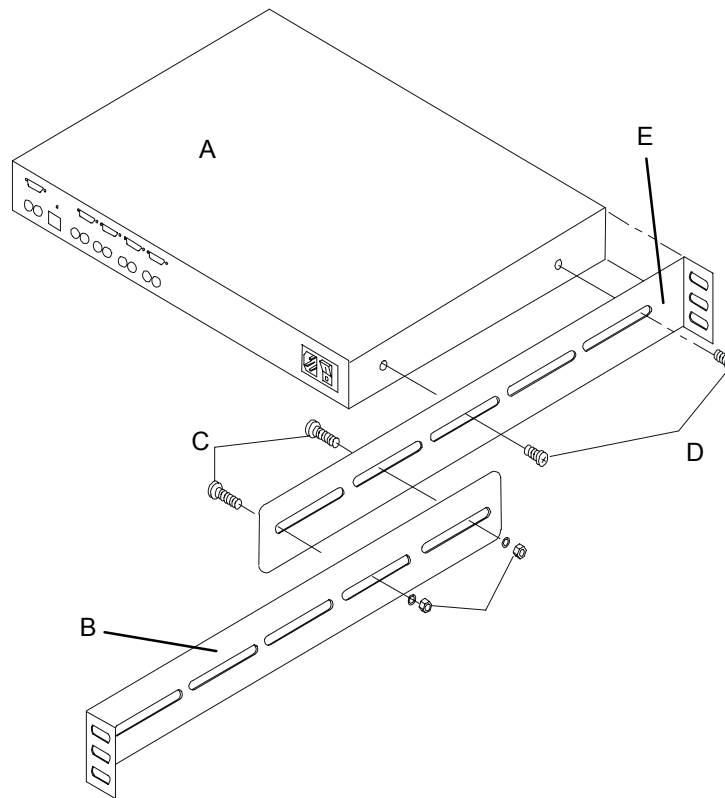

- A. Concentrator
- B. Rear Concentrator Rail
- C. Concentrator Rail Screws
- D. Concentrator Mounting Screws
- E. Front Concentrator Rail

Figure 5-11. Assembling the Concentrator Rails

4. Adjust the length of the concentrator rails to fit between the outside of the front and rear vertical posts in the system rack.
5. Attach the two side rails to the sides of the concentrator with the four shorter screws (Figure 5-11, D) received with the concentrator.

-
4. Install the supporting cage-nuts in the rail. See Figure 5-12.

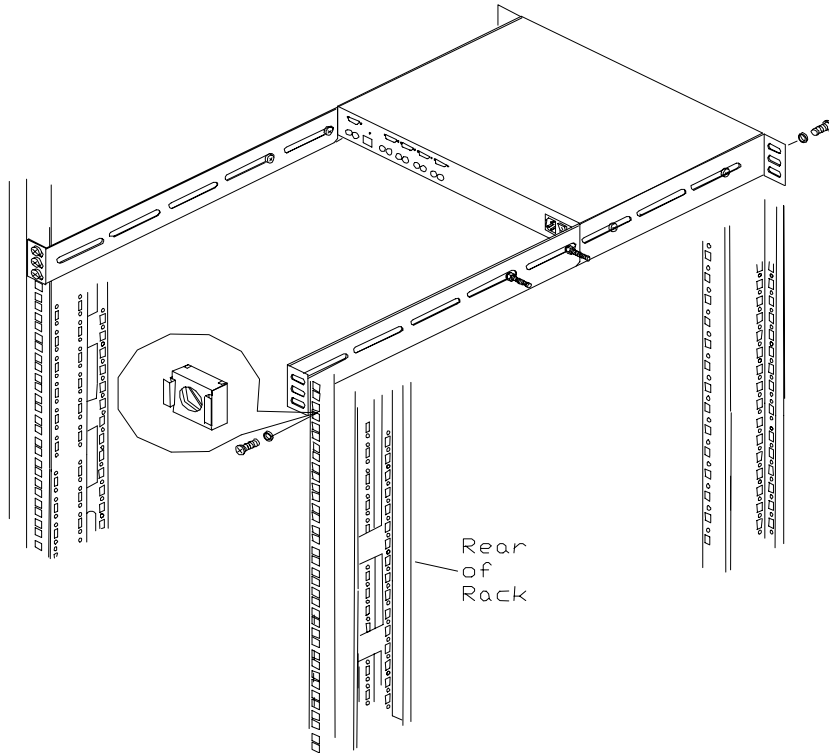



Figure 5-12. Installing the Port Concentrator

5. Attach the side rails and concentrator to the system rack with plated finish screws and washers that you received with the system rack.

 **Note:** The concentrator connector panel should face the rear of the system rack and the blank panel should face the front of the system rack.

Installing Blank Panels

This section describes how to install blank filler panels on the front of your system rack to give your rack a finished look.

Blank filler panels are available in the following sizes:

- 1U (1.75")
- 2U (3.5")
- 3U (5.25")
- 6U (10.5").

As shown in Figure 5-13, blank panels are attached to the front of the system rack with cage-nuts, black plastic washers, and the Phillips-head screws, that you received with the system rack.

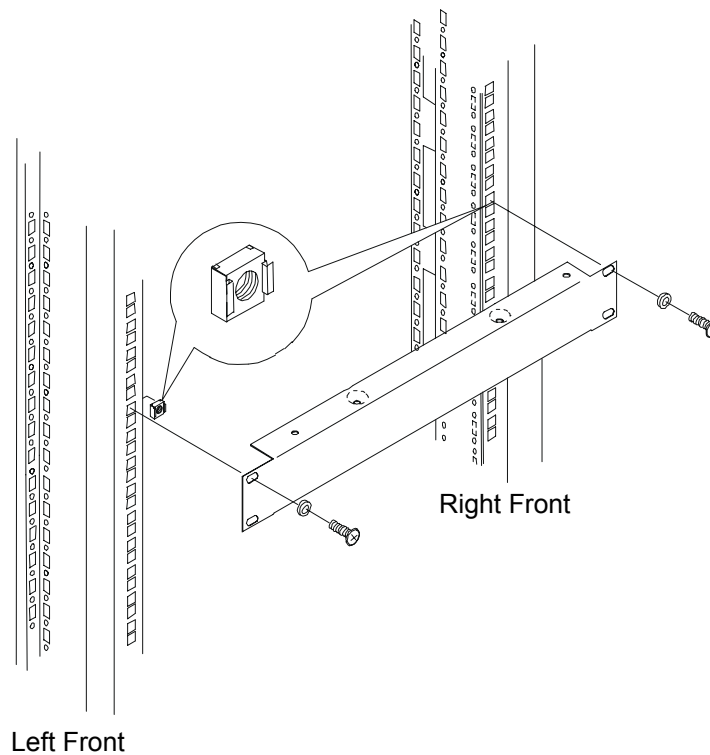

Figure 5-13. Installing a 1U Filler Panel

Installing a Monitor Tray

This section describes how to install a monitor tray into a system rack. The monitor tray provides a convenient work surface for your video monitor.

Perform the following steps to attach your monitor tray:

1. Determine the location for the monitor tray.
2. Install the four M6 cage-nuts that will secure the front of the monitor tray to the front rack rails. Position the cage-nuts to align with the screw holes in the front of the tray. See Figure 5-14, A.

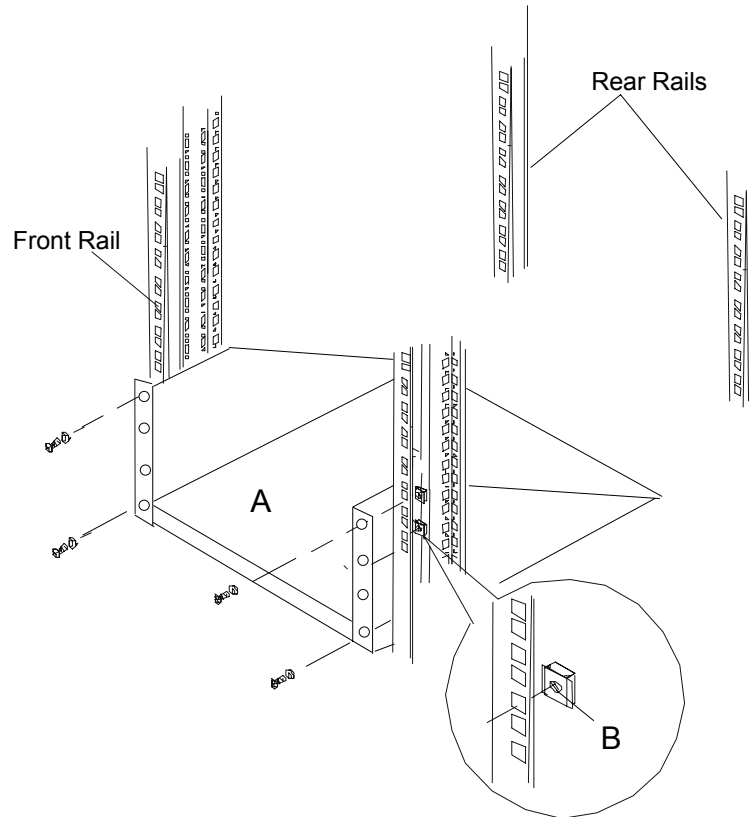



Figure 5-14. Monitor Tray and Mounting Hardware

3. Position the monitor tray inside the rack and secure the monitor tray to the rails using the black plastic washers and 3 plated-finish screws.

Connecting the Console Monitor

Perform the following steps to connect the console monitor to the concentrator.

1. The keyboard, mouse, and video display cables attach to the first group of connectors on the left of the concentrator when viewed from the rear. See Figure 5-15.
2. The top-most connector is for the monitor (Figure 5-15, A). Below the monitor connector, connect the keyboard to the keyboard connector (K) and connect the mouse to the mouse connector (M).

 **Note:** If necessary, you can use 12-ft extension cables to achieve overall cable lengths of 19-ft or 24-ft to accommodate the placement of your console monitor on external desktop.

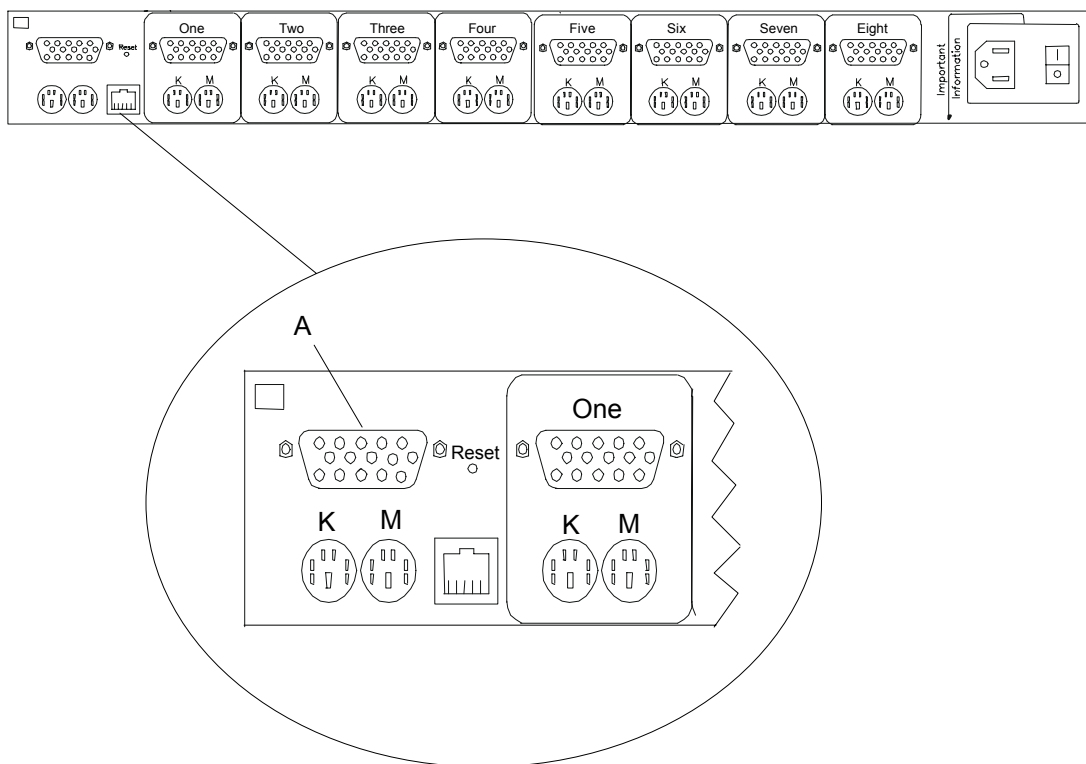

Figure 5-15. Connecting Cables to the Port Concentrator

Connecting Servers (BSUs) to the Concentrator

1. Connect the keyboard, mouse, and video display cable from each server to one of the concentrator connector groups labeled one through eight. See Figure 5-15.
2. Attach the AC power cord to the receptacle located next to the power on/off switch on the right side of the concentrator when viewed from the rear. Connect the other end of this power cord to the PDU or UPS.

6

Illustrated Parts Breakdown

- Field Replaceable Units
- Options

This chapter helps you identify the Field Replaceable Units (FRUs) for the rack assembly. A list of available options for a rack system is also included in this chapter.

Figure 6-1 illustrates the 42U Rack and includes numbered callouts that refer to the reference numbers listed in Table 6-1. Table 6-1 lists the part numbers for all rack assembly FRUs.

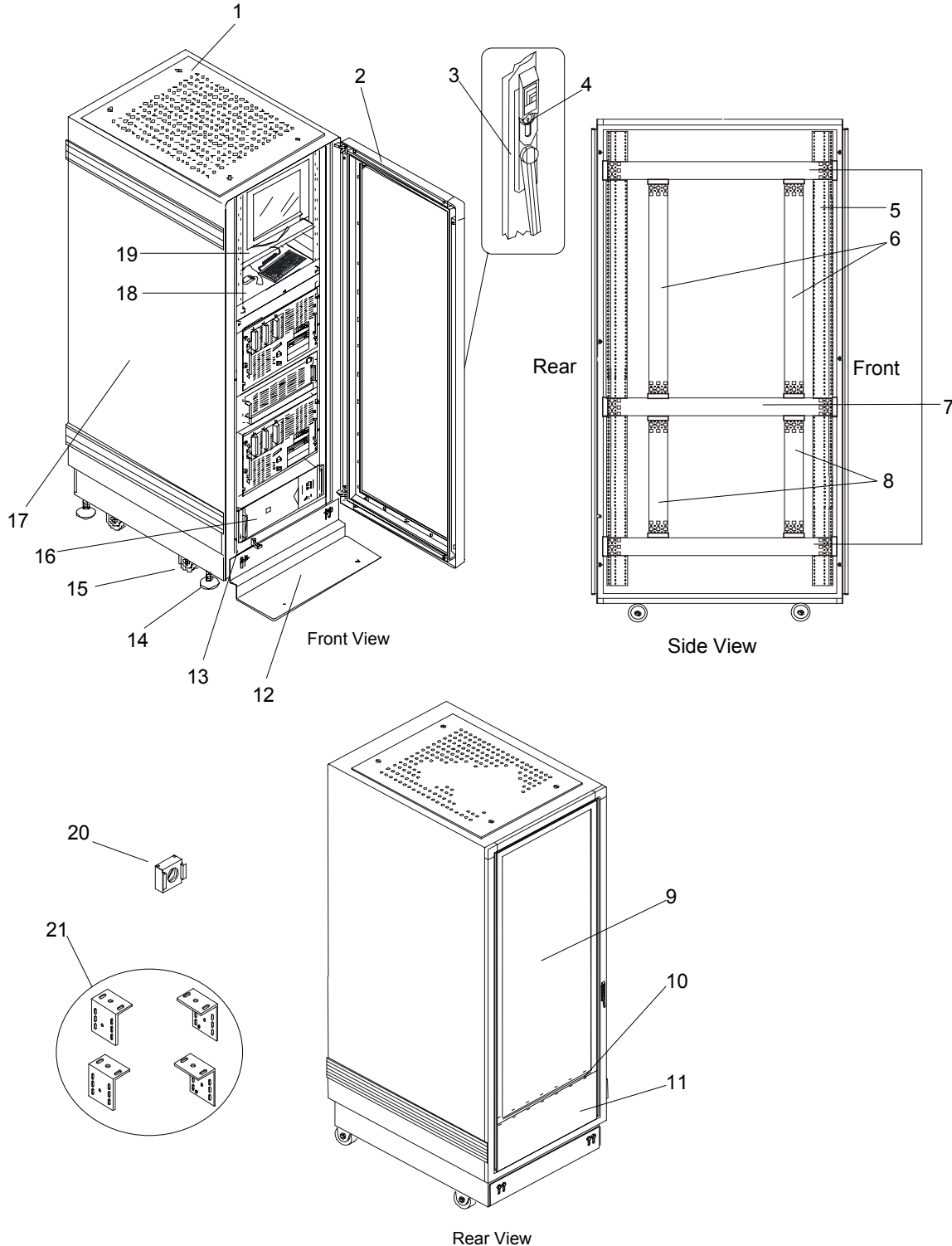

Figure 6-1. Field Replaceable Unit Locations

Field Replaceable Units

Table 6-1 lists the Field Replaceable Units for the three rack models. Unless otherwise noted part numbers shown are for use in the United States and Europe.

Table 6-1. Field Replaceable Units

Reference Number	Description	42U Rack Enclosure (AZA-4200) 2000mm x 600mm x 1000mm	36U Rack Enclosure (AZA-3600) 1800mm x 600mm x 1000mm	27U Rack Enclosure (AZA-2700) 1400mm x 600mm x 1000mm
1	Roof, Perforated	247-01652-000	247-01652-000	247-01652-000
2	Door, Front, Includes handle and lock insert	247-01628-000	247-01629-000	247-01648-000
3	Door, Front Handle	247-01630-000	247-01630-000	247-01630-000
4	Keylock Insert	247-01631-000	247-01631-000	247-01631-000
5	Rail, Front or rear vertical 19"	247-01638-000	247-01645-000	247-01651-000
6	Rail, System chassis vertical	247-01639-000 (900mm)	247-01646-000 (700mm)	247-01640-000 (500mm)
7	Rail, System chassis horizontal	247-01639-000 (900mm)	247-01639-000 (900mm)	247-01639-000 (900mm)
8	Rail, System chassis vertical	247-01640-000 (500mm)	247-01640-000 (500mm)	247-01647-000 (300mm)
9	Door, Rear	247-01629-000	247-01643-000	247-01649-000
10	Cross Mullion	247-01633-000	247-01633-000	247-01633-000
11	Panel, Solid partial	247-01632-000	247-01632-000	247-01632-000
12	Stabilizer, Front	247-01642-000	247-01642-000	247-01642-000
13	Base, Mobile	247-01635-000	247-01635-000	247-01635-000
14	Foot, Leveling	247-01637-000	247-01637-000	247-01637-000
15	Castor, 80mm swivel	247-01636-000	247-01636-000	247-01636-000
16	UPS, Rackmount 3000VA 3U	148435-01	148435-01	148435-01
17	Panel, Side	247-01634-000	247-01644-000	247-01650-000
18	Kit Keyboard/Mouse Tray	050-01628-000	050-01628-000	050-01628-000
19	Rittal Monitor Tray Kit	050-01636-000	050-01636-000	050-01636-000
20	Nuts, Captive	250-01510-000	250-01510-000	250-01510-000

Table 6-1. Field Replaceable Units (Continued)

Reference Number	Description	42U Rack Enclosure (AZA-4200) 2000mm x 600mm x 1000mm	36U Rack Enclosure (AZA-3600) 1800mm x 600mm x 1000mm	27U Rack Enclosure (AZA-2700) 1400mm x 600mm x 1000mm
21	Rack Frame Link	050-01627-000	050-01627-000	050-01627-000
Figure 5-11	8-port Concentrator	6758130000	6758130000	6758130000
Figure 5-11	8-port Concentrator Rack Mount Kit	1451960000	1451960000	1451960000
Figure 5-9	Power Distribution Unit, 120v, PT3500 Rackmount	149068	149068	149068
Figure 5-11	UPS Interface Expander	149576	149576	149576
Figure 5-13	1u Blank Filler Panel Kit M/W	050-01632-000	050-01632-000	050-01632-000
	2u Blank Filler Panel Kit M/W	050-01630-000	050-01630-000	050-01630-000
	3u Blank Filler Panel Kit M/W	050-01625-000	050-01625-000	050-01625-000
	6u Blank Filler Panel Kit M/W	050-01626-000	050-01626-000	050-01626-000
	Rittal Side Stabilizer	6774270000	6774270000	6774270000
	Server Cable Simple For UPS	070541	070541	070541
	Cable Set, 12' Mouse/Video/Keyboard Extension	0705390000	0705390000	0705390000
	Cable Set, Switchbox, 12 Foot, Server To SW	0706310000	0706310000	0706310000
	Cable Set, Switchbox, 7 Foot, Server To SW	0705380000	0705380000	0705380000
	Bracket, Combination	247-01641-000	247-01641-000	247-01641-000
	Screws, Phillips	250-01509-000	250-01509-000	250-01509-000

Options

Table 6-2 lists the options available for your rack assembly. Contact your local representative for more information.

Table 6-2. Options

Part Number	Description
ACN-0011-00-00	Cable Set, 12' Mouse/Video/Keyboard Extension
ACN-0010-00-00	Cable Set, Switchbox, 12 Foot, Server To SW
ACN-0009-00-00	Cable Set, Switchbox, 7 Foot, Server To SW
AEX-8000-00-US	8-Port Switchbox For Servers
AZA-4001-00-00	Rack Frame Link Kit (links two racks together)
AZA-4002-00-00	1U Blank Filler Panel Kit M/W
AZA-4003-00-00	2U Blank Filler Panel Kit M/W
AZA-4004-00-00	3U Blank Filler Panel Kit M/W
AZA-4005-00-00	6U Blank Filler Panel Kit M/W
AZA-4006-00-00	Front Mount Monitor Tray Kit
AZA-4007-00-00	Keyboard/Mouse Tray Kit
AZA-3007-00-00	Non Swivel Keyboard Tray
AIB-0080-00-00	Slim Keyboard
AZA-4008-00-00	Side Stabilizer Kit (two side stabilizers)
ASP-0001-00-US	Power Strip, 120v Pt3500 (PDU)
ABA-3000-00-US	Rack-mount 3000VA 3U RM (UPS)

Index

A

Air Conditioning, 2-9
cooling capacity, 2-9

B

Blank Panels
installing, 5-17

C

Cable Restrictions
RAID, 3-3
Cable Summary, 3-2
Cabling Constraints, 3-2
Concentrator
installing, 5-14
Concentrator Cable Lengths, 3-3
Configuration Assistant, 1-2

E

Electrical Facilities, 2-10
Environmental Conditions, 2-4
Equipment Location
equipment, 2-2

F

Field Replaceable Units, 6-3

G

Grounding Requirements, 2-11

I

Illustrated Parts Breakdown, 6-1

K

Keyboard Tray
installing, 5-13

M

Monitor
connecting.
Monitor Tray
installing.

O

Options, 6-5

P

Power Distribution Unit
installing, 5-12
requirements, 2-10

R

Rack
configuration guidelines, 3-6
floor requirements, 2-5
leveling, 4-7
opening doors, 4-5
space requirements, 2-2
spacing components, 3-3
unpacking, 4-3
Rack Components
installing, 5-3
Rack Frame Link Kits
installing, 4-8
Rack Stabilizer
installing, 4-10

S

Server
master and protected, 5-10
Side Panels
removing, 4-6
System
configuring, 4-10
System Rack Models
Rack Models, 1-2
System Rack Placement, 2-7
System Rack, 42U, 1-3
System Rack, Multi-Bay, 1-5

T

Typical Configuration, 5-2

U

Uninterruptible Power Source (UPS, 2-10
UPS
installing, 5-4
interface expander accessory, 5-6
load calculation and battery run time, 3-8

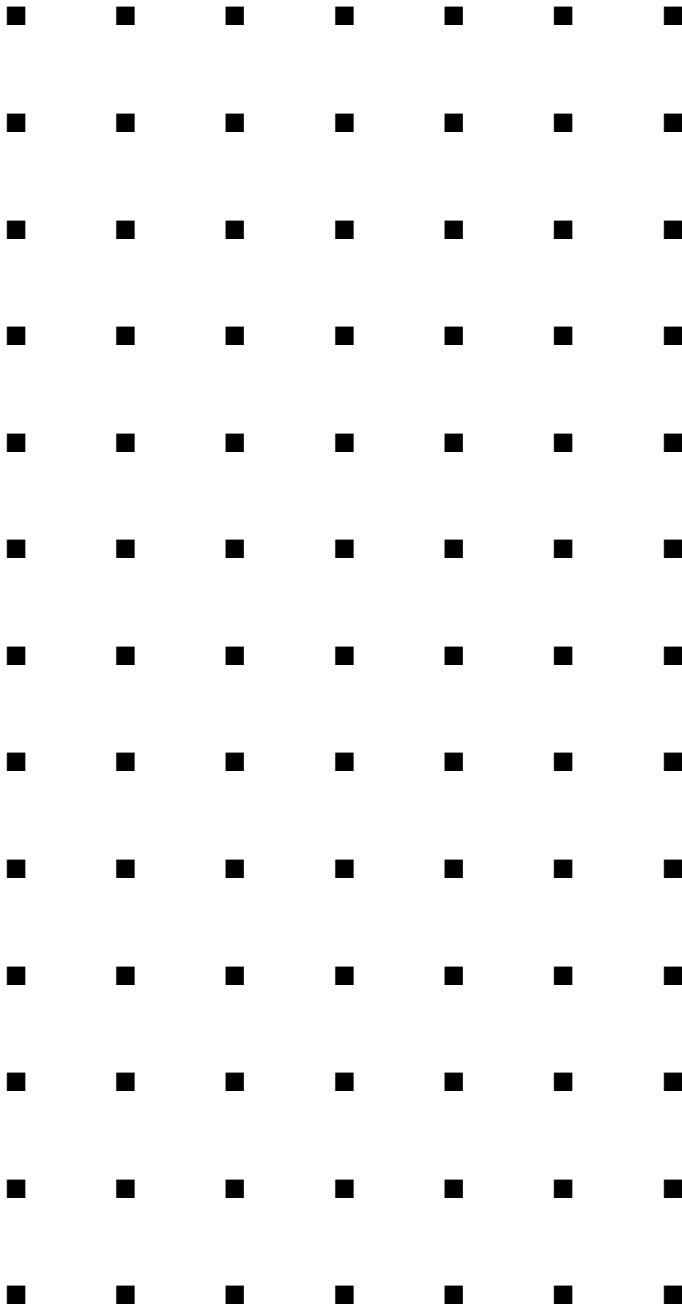

456-01544-000