

Profoto Battery

Profoto
Pro-7b
1200

Profoto
Pro B2
1200





AUSTIN POWDER COMPANY
EXPLOSIVE
DANGER
EXPLODIF
PELIGRO
EXPLOSIVO

Bringing your light

Working on location is always a challenge. There's not enough time. There's not enough light. And worse: there's no electricity.

The Profoto line of battery flash generators eliminates the dependency of electricity, without compromising the quality of the light or the famous Profoto versatility and ease of use.

If you need heavy-duty studio performance wherever you go, consider the Pro-B2 or the Pro-7b. They both give you 1200 Ws power, enough to balance even direct sunlight with two asymmetric outlets and plenty of control.

If your main objective is simplicity and low weight, we offer the AcuteB, sporting an impressive 7 f-stop range in a very small package and still capable of up to 160 flashes at 600 Ws.

Just like every other Profoto generator, the battery products are compatible with the entire range of Profoto Light Shaping Tools and other accessories. So if you need extra equipment, your local dealer or rental studio can provide the tools you need.

Like all Profoto equipment the battery generators are also designed for heavy-duty use, they are durable and feature intelligently placed knobs, buttons and handles. Simplicity is king!

Never settle for anything less than your own light.

All Profoto battery generators...

- Can operate as normal studio generators when connected, even while charging.
- Are fully compatible with the entire range of Profoto Light Shaping Tools.
- Can be charged in a car.
Car Cigarette Lighter. (Only Pro-B2 and Pro-7b).
- Provides extreme colour and power stability from flash to flash.

Profoto Pro-B2

- Up to 200 full power flashes from a single battery cassette.
- Ultrafast recycling: 0.04 – 1.8 sec.
- Very short flash durations: 1/2200 – 1/7400 sec.
- Full 8 f-stop range in 1/2 or 1/10 step adjustments.
- Asymmetrical or symmetrical power distribution.
- Up to 250 W modeling lamp.
- Built-in radio (optional).
- Continuous modeling light or timer.

Profoto Pro-7b

- Up to 250 full power flashes from a single battery cassette.
- Fast recycling: 0.09 – 2.8 sec.
- Motion-freezing flash durations: 1/1400 – 1/3000 sec.
- Full 7 f-stop range in 1/6 step adjustments.
- Asymmetrical or symmetrical power distribution.
- 100 W modeling lamp.

Profoto AcuteB 600

- Up to 160 full power flashes from a single battery cassette.
- Fast recycling: 0.09 – 2.6 sec.
- Motion-freezing flash durations: 1/1000 - 1/6800 sec.
- Full 7 f-stop range in 2/10 step adjustments.
- Special 65 W modeling lamp (with the brightness of 90 W).
- Very handy: 19 x 19 x 13 cm (including handle) at 4.9 kg.
- Built-in radio (optional).





We have a battery generator for everyone

Needless to say, we offer very powerful battery generators, with performance surpassing many regular flash units. But we also offer battery packs for those who need something a little less powerful - or when the first priority is to travel light.



Pro-B2 - The world's fastest battery generator

Imagine a top-of-the-line, heavy-duty 1200Ws studio generator. Now imagine disconnecting the power cable from the wall and bringing Profoto Performance wherever you happen to be shooting. That's the Profoto Pro-B2. With performance surpassing a lot of traditional studio flashes, the Profoto Pro-B2 is our top-of-the-line battery generator. It's all there: an 8 f-stop range, a 250 W modeling light, recycling in 0.04-1.8 s, and built-in radio sync (optional). So if you need power on the go, without compromise, the Profoto Pro-B2 is the natural choice.



Pro-7b - Studio quality light on the go

If you're looking for both portable and truly affordable studio quality light, look no further than to the Profoto Pro-7b. With an effective 250 full power 1200 Ws flashes per battery, recycling between 0.09 and 2.8 seconds, and

flash durations down to a 1/3000 seconds, the Pro-7b will give you the light you need, wherever you need it. The Profoto Pro-7b is the battery pack for everybody with serious lighting needs when away from the studio, but without the need for ultra-fast recycling and extremely short flash durations of the Profoto Pro-B2.



AcuteB 600 - The pack you can, and will, bring anywhere

The AcuteB is nothing less than a miracle. In a compact form, (the size of a stack of VCR tapes,) and weighing less than 5 kg, you have a seven f-stop range from 9-600 Ws, 160 full power flashes per battery and built-in wireless radio sync (optional). Using the AcuteB Head you can just put it all in a backpack and walk away, freely, with nothing short of an entire studio on your back. The bottom line? That you can - and will - bring high-quality light wherever you go.



Tough, roomy and forgiving - introducing the Profoto batteries

We're using the latest sealed lead/acid technology batteries, combining maximum capacity with fast recharging and, not least important, penalty-free partial charging. Because we understand you don't always have the time to fully charge or discharge a battery.

Additional battery cassettes for rapid replacement ensure you are never out of power, no matter how far away from an outlet you are.





We wouldn't dream of standing in your way

As a professional photographer, you have your own special style and needs. You know the expression you want to achieve, and you don't feel good until you can shape the light your way. Therefore, the Profoto Light Shaping System is based on the principle of maximum flexibility.

First of all, we put the flash tube outside of the lamp body, and we made every single Light Shaping Tool zoomable. The result is that every single tool offers an unlimited number of lighting effects. Secondly, the Profoto family of Light Shaping Tools is very comprehensive, ranging from traditional umbrellas and reflectors, to special effects equipment and the very large Giant Reflectors and the advanced StripLights and Spotlights. So you can choose the exact tool you need. And then zoom it to perfection. Because only you can tell what your light looks like. Your equipment should not stand in your way.



Grab and move

The sturdy, rubber-clad handle on the lamp head takes the hassle out of adjusting the light - even when the head is hot after hours of shooting.

"Set it on five!"

On every lamp head there is a scale with large white figures to help you remember your favorite settings for each Light Shaping Tool.

Changing tools is easy

The Profoto Light Shaping Tools are all fastened using a virtually unbreakable, and very easy to use, rubber-and-metal clasp.

Just zoom it

By pushing the reflector forward and backward on the lamphead, the spread and effect of the light can be greatly altered. Pushed back it gives very even lighting over a broad area. Sliding it forward results in center weighted light with a gradual light fall off at the edges.

You can touch it

Thick rubber shields from the heat when changing tools.



The guiding is there

To guide you when zooming the Light Shaping Tool, there is a chart on each one telling you where to zoom it, corresponding to the number on the lamp head, to achieve a certain effect.

We have the tools you need

Reflectors, umbrellas, softboxes, grids, spotlights, special effects, ring flashes, striplights - the Profoto line of Light Shaping Tools offers everything you might possibly need.

Lamp heads for the Pro-B2 and the Pro-7b

If you choose one of our most powerful battery generators you can use all the lamp heads that fits the state-of-the-art Pro-7 series - plus the light-weight Pro-B Head.



ProHead Fan Cooled Head
90 07 09 with 250 W Halogen lamp

In the studio, the standard heavy-duty tool is the Profoto ProHead, built for producing flashes up to 4800 Ws, over and over again, hour after hour. The fan works when the head is used on the Pro-B2.

The ProHead includes: Zoom Reflector, quartz flash tube, 250 W halogen lamp, removable frosted glass cover, protective transportation cap, stand adapter and a 4 m (13 ft) lamp cable.



Pro-B Head
90 07 25

For the Pro-B2 and the Pro-7b there is the handy Profoto Pro-B Head, that gives you 1200 Ws flashes and a 100 W modeling light while still weighing only 1.8 kg.

The Pro-B includes: Disc Reflector, flash tube, 100 W halogen lamp, removable frosted glass cover, protective transportation cap, stand adapter, and a 4 m (13 ft) lamp cable.

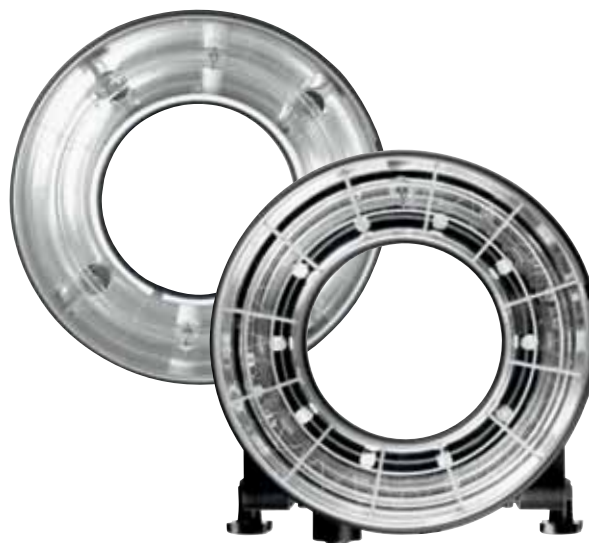

ProRing 2 30 05 17
ProRing 30 05 15

For fashion or other occasions when you want a direct and very prominent light, there is the Profoto ProRing 2, a ring flash capable of as many 2400 Ws flashes per minute as the generator can produce, and also including a powerful 200 W modeling light.

If you look for a more light-weight ring flash without modeling light, there's also the Profoto ProRing, with the capacity of up to eight 2400 Ws flashes per minute.

The ProRing 2 includes: circular quartz flash tube, 10 x 20 W halogen modeling lamps, camera adapter, stand adapter and a 4 m (13 ft) special lamp cable.

The ProRing includes: circular flash tube, camera adapter, stand adapter, and a 4 m (13 ft) special lamp cable.

ProRing and ProRing 2 accessories: Close-up Reflector, Softlight Reflector, Widesoft Reflector and ProRing Diffuser.



ProTwin
90 07 19

For even tougher demands, there is the Profoto ProTwin, that, using two flash tubes, effectively doubles the performance of the ProHead. When used with a single generator, it produces shorter flash duration. Used with two generators, it achieves faster recycling and/or higher power, up to 4800 Ws.

The ProTwin includes: Magnum Reflector, two uncoated flash tubes, 500 W halogen modeling lamp, removable frosted glass cover, protective transportation cap, stand adapter and a special 4.5 m (14,5 ft) long Twin Lamp cable.





Lamp heads for the AcuteB 600/600R

If you choose our most portable battery generator, you still have a wide choice of lamp heads, namely the entire Acute/D4 series - plus the super-light-weight AcuteB Head.



Acute/D4 Head

90 06 66

With a modeling light of 250 W and a maximum flash output of 4800 Ws, the Acute/D4 Head is the top of the line lamp head for all Acute generators, as well as the Profoto D4.

When using this head on the AcuteB 600 there is a special adapter allowing you to use the high-performance 65 W lamp.

The Acute/D4 Head includes: Zoom Reflector, flash tube, 250 W halogen lamp, removable frosted glass cover, protective transportation cap, and a 4 m (13 ft) lamp cable.



AcuteB Head

90 09 35 with with Disc reflector

90 09 36 with with Zoom reflector

With our smallest battery pack, the AcuteB 600, there is also a special lamp head, the Profoto AcuteB Head, that, at a mere 1.45 kg, gives you 600 Ws flashes and an innovative modeling light, using a high-performance halogen lamp that, at 65 W, gives you the brightness of 90 W. For you, when combined with its fan-free cooling, this translates to longer lasting batteries.

The AcuteB Head includes: flash tube, 65 W halogen lamp, protective transportation cap and a 3 m (10 ft) lamp cable.



Acute/D4 Twin

90 06 78

Much like the ProTwin, the Profoto Acute/D4 Twin doubles the performance of a normal head, resulting in either shorter flash duration when used with a single generator, or faster recycling/higher power, when used with two generators. The Acute/D4 Twin can produce flashes up to 1200 Ws, when used with two AcuteB 600 generators (and up to 9600 Ws with two Profoto D4 4800).

The Acute/D4 Twin includes: Magnum Reflector, two flash tubes, 500 W halogen lamp, removable frosted glass cover, protective transportation cap, stand adapter and a split, 4 m (13 ft) lamp cable.



Acute/D4 Ring

33 05 13

The Acute/D4 Ring is a powerful ring flash capable of producing, for example, 16 flashes at 600 Ws or 64 flashes at 150 Ws per minute. Fits most cameras and lenses up to a diameter of 100 mm.

The Acute/D4 Ring includes: circular flash tube, glass cover, camera adapter, stand adapter and a 4 m (13 ft) lamp cable.

Profoto – The Light

MONOLIGHTS AND GENERATORS



ComPact 300

ComPact Plus 600

ComPact Plus 1200



Acute2 1200/2400



Acute2R 1200/2400
(with radio slave module)



AcuteB 600/AcuteB 600R
(with or without radio)

HEADS



ProTungsten



StickLight 10 07 38

Glass covers



AcuteB Head
90 09 35



Acute/D4Head
90 06 66



Acute/D4 Twin
90 06 78

LIGHT SHAPING TOOLS

Narrow Beam
Travel Reflector
10 07 13



Narrow Beam Reflector
10 06 17



TeleZoom Reflector
10 07 12



Magnum Reflector
10 06 24



Wide Zoom Reflector
10 07 11



Standard Zoom Reflector
10 06 10



Grid Reflector
10 07 05



Disc Reflector
10 06 54



10° Grid
10 06 18



Pro Tube
10 06 70

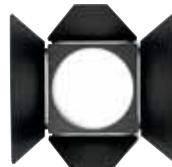

Barn Doors
10 07 15



10° WideZoom grid
10 06 36

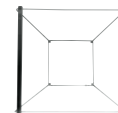

Filter Holder
10 07 01



Grid - and filter holder
90 06 49



Barn Doors
10 06 71

7" (18cm) Grids
5° -10 06 35
10° -10 06 34



Snoot
10 06 51



5°, 10°, 20° Grids
10 06 46, 10 06 05, 10 06 06



5' (1,5m) Giant Reflector 10 03 11, 7' (2,1m) Giant Reflector 10 03 12,
8' (2,5m) Giant Reflector 10 03 13
Diffusers available (-1/3 and 1 f-stop)



StripLights
S 27.6" (70cm) -10 07 35
M 51" (130cm) -10 07 36
L 74.8" (190cm) -10 07 37



Softbox 1x3' RF
(30x90cm)
25 45 36

Softbox 1x4' RF
(30x120cm)
25 45 24

Softbox 1x6' RF
(30x180cm)
25 45 34

Softbox 2x2' RF
(60x60cm)
25 45 25

Shaping System



D4-1200/2400/4800 (with or without radio) Pro-B2 1200/1200R (with optional radio slave module) Pro-7b Pro-7s 1200 Pro-7s 2400 Pro-7a 1200 Pro-7a 2400



Acute/D4 Ring 33 05 13 Pro-B Head 90 07 25 ProHead 90 07 09 ProTwin 90 07 19 ProRing / ProRing 2 30 05 15/30 05 17



ProGlobe 10 06 73 Softlight Reflector silver 10 06 07 Softlight Reflector white 10 06 08 FresnelSpot 10 07 41 Barn Doors for FresnelSpot 10 07 58

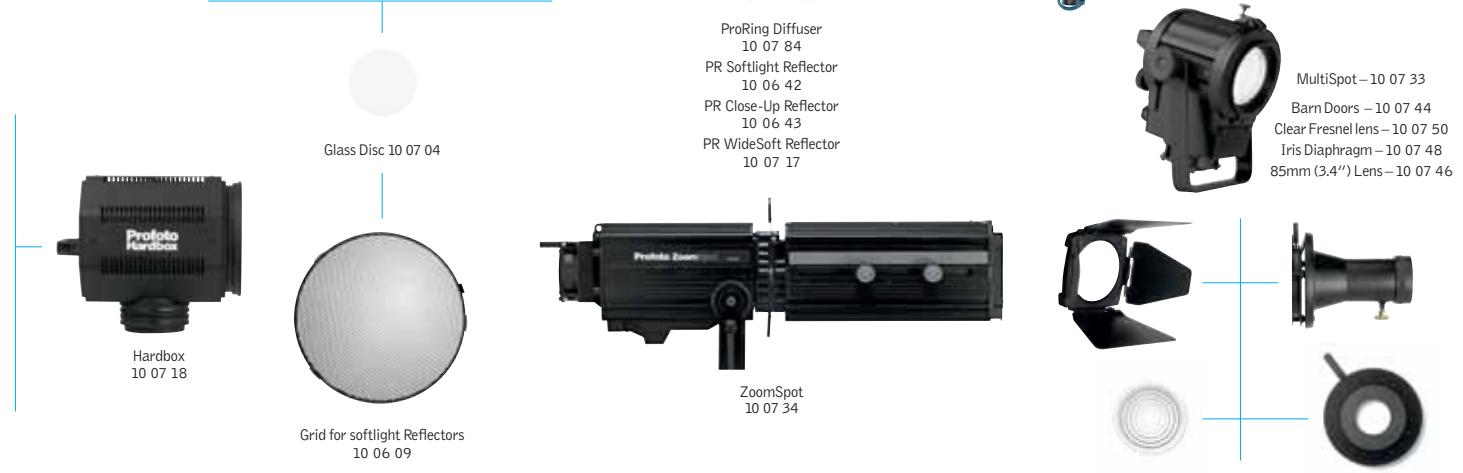

Glass Disc 10 07 04 Hardbox 10 07 18 Grid for softlight Reflectors 10 06 09 ZoomSpot 10 07 34 ProRing Diffuser 10 07 84 PR Softlight Reflector 10 06 42 PR Close-Up Reflector 10 06 43 PR WideSoft Reflector 10 07 17 MultiSpot-10 07 33 Barn Doors -10 07 44 Clear Fresnel lens-10 07 50 Iris Diaphragm-10 07 48 85mm (3.4") Lens-10 07 46

Softgrids, masks and diffusers available.

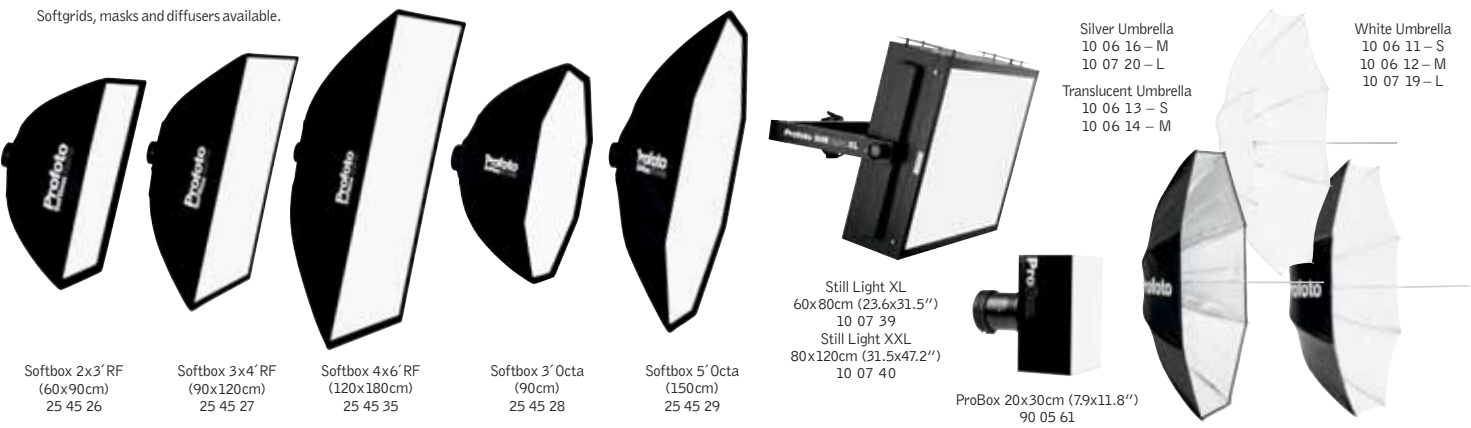

Softbox 2x3' RF (60x90cm) 25 45 26 Softbox 3x4' RF (90x120cm) 25 45 27 Softbox 4x6' RF (120x180cm) 25 45 35 Softbox 3' Octa (90cm) 25 45 28 Softbox 5' Octa (150cm) 25 45 29 Still Light XL 60x80cm (23.6x31.5") 10 07 39 Still Light XXL 80x120cm (31.5x47.2") 10 07 40 ProBox 20x30cm (79x11.8") 90 05 61 Silver Umbrella 10 06 16 - M 10 07 20 - L Translucent Umbrella 10 06 13 - S 10 06 14 - M White Umbrella 10 06 11 - S 10 06 12 - M 10 07 19 - L





High-voltage power controlled by sophisticated electronics

Building a modern flash generator raises a lot of challenges. To start with, generators contain two separate technological systems: There are microprocessors and integrated circuits for control, external interfaces and display. And there are also powerful high-voltage components that generates the actual flash.

Not only do the two system have to coincide in the same limited space, they must also cooperate perfectly, without disturbing each other. If not, the 1/10 step adjustments and the Profoto 1/100 f-stop accuracy would not be possible.

Finally, these two systems must interface a third one: the professional photographer. That means reducing all the complicated technology to a simple and rugged set of knobs, buttons and outlets.

In conclusion, all Profoto generators:

- produce highest quality light, with extreme accuracy, without being complicated to use.
- are built using durable and finger-friendly materials.
- have a carefully designed layout, in order to make your everyday work as easy as possible.
- feature maximum security safety when it comes to high-voltage components and plugs.
- give you visual, audible, as well as tactile feedback - seeing, hearing, feeling.

Profoto Pro-B2

Technical data:

Energy: 1200 Ws

Energy control: Over an eight f-stop range (down to 9 Ws). In 1/10 or 1/2 step adjustments

Energy distribution: Symmetric or Asymmetric (2:1 ratio)

F-stop @ 2 m: w/ Magnum 90.3

Recycling: 0.04-1.8 sec.

Flash duration: 1/2200-1/7400 sec.

Flash capacity: Up to 200 full power flashes per charge

Modeling Light: Up to 250 W continuous or time controlled (max 60 sec.)

Battery: Non spillable lead/acid battery in a battery cassette for rapid exchange

Charging time: 5 hours (standard Profoto Charger 2A), 2.5 hours (Universal Power Adapter)

Auto dumping: Yes

N° of lamp outlets: 2

Sync contact: 2

Energy precision: 1/100 f-stop flash to flash

Sync Voltage: Compliant to ISO 10330 Standard

Size: 26 x 17 x 23 cm including handle (10 x 6.75 x 9 inches)

Weight: 11,5 kg including battery (25 pounds)

Others: Indicator for battery status, for 1/1, 3/4, 1/2 and 1/4 power; built in photocell w/ on/off switch

Optional built in Radio with 32 channel / 4 zone for remote operation

Nomenclature:

- 1: Main power on/off
- 2: Model light timer
- 3: Fast/slow recycling
- 4: Sound on/off
- 5: Slave on/off
- 6: Dual sync sockets
- 7: Photo/IR-cell
- 8: Charge inlet
- 9: Indicator for battery charge
- 10: Head connection
- 11: SYM/ASYM Switch
- 12: Energy control 1/2 f-stop
- 13: Energy control 1/10 f-stop
- 14: Radio channels
- 15: Model Light Cont/Timer



①

②

③

④

⑤

⑥

⑦

⑮

⑧

⑨

⑭

⑩

⑬

⑪

⑩

⑫



Profoto Pro-7b

Technical data:

Energy: 1200 Ws

Energy control: Over a seven f-stop range (down to 18 Ws). In 1/6 step adjustments

Energy distribution: Symmetric or Asymmetric (2:1 ratio)

F-stop @ 2 m: w/ Magnum 90.3

Recycling: 0.09-2.8 sec.

Flash duration: 1/1400-1/3000 sec.

Flash capacity: Up to 250 full power flashes per charge

Modeling Light: 100 W time controlled (max 60 sec.)

Battery: Non spillable lead/acid battery in a battery cassette for rapid exchange

Charging time: 5 hours (standard Profoto Charger 2A), 2.5 hours (Universal Power Adapter)

Auto dumping: Yes

N° of lamp outlets: 2

Sync contact: 2

Energy precision: 1/100 f-stop flash to flash

Sync Voltage: Compliant to ISO 10330 Standard

Size: 24 x 17 x 23 cm including handle (9.5 x 6.75 x 9 inches)

Weight: 11,5 kg including battery (25 pounds)

Others: Indicator for battery status, for 1/1, 3/4, 1/2 and 1/4 power; built in photocell w/ on/off switch

Nomenclature:

- 1: Main power on/off
- 2: Model light timer
- 3: Fast/slow recycling
- 4: Sound on/off
- 5: Slave on/off
- 6: Dual sync sockets
- 7: Photo/IR-cell
- 8: Charge inlet
- 9: Indicator for battery charge
- 10: Head connection
- 11: SYM/ASYM Switch
- 12: Energy control 1/6 f-stop



Profoto AcuteB 600

Technical data:

Energy: 600 Ws

Energy control: Over a seven f-stop range (down to 9 Ws). In 2/10 step adjustments

F-stop @ 2 m: w/ Magnum 64.2

Recycling: 0.09-2.6 sec.

Flash duration: 1/1000-1/6800 sec.

Flash capacity: Up to 160 full power flashes per charge

Modeling Light: 65 W continuous modeling light

Battery: 12 V 5Ah. Non spillable lead/acid battery

Charging time: 5 hours (standard Profoto Charger 1A), 2.5 hours (Profoto Charger 2A)

Auto dumping: Yes

N° of lamp outlets: 1

Sync contact: 1

Energy precision: 1/75 f-stop flash to flash

Sync Voltage: Compliant to ISO 10330 Standard

Size: 19 x 19 x 13 cm (7.5 x 7.5 x 5 inches) including handle

Weight: 4.9 kg including battery (10.8 pounds)

Others: Indicator for battery status, for 1/1, 1/2 and 1/4 power; built in photocell

Optional built in Radio with 32 channel / 4 zone for remote operation

Nomenclature:

- 1: Lamp Head Socket
- 2: Charge Inlet
- 3: Modeling Light Power Inlet
- 4: Sync Socket
- 5: Photo/IR-cell
- 6: Slave on/of
- 7: Ready Lamp & Test Button
- 8: Main power on/of
- 9: Indicator for battery charge
- 10: Modeling Light control Switch
- 11: Energy Control, fine adjustment 2/10 f-stop
- 12: Energy Control 2 f-stop
- 13: Sound on/off







Flash equipment is a lot about technology. Photographers are not.

Even though it takes advanced electronics to control a modern flash generator, there will be a human being operating the pack. There will be a hand of flesh and blood turning the knobs, carrying the pack, and inserting the cables. And there might be eyes tired from many hours of shooting that's checking the dials.

Design matters

All in all, the exterior design is just as important as the interior electronics. If not more. That's why Profoto has given the area a lot of attention, ever since we started out in the late 60s.

Simplicity is king

The main design principle at Profoto is simplicity. That goes hand in hand with durability. Like the metal-and-rubber clasp used to mount Light Shaping Tools: you immediately understand how it works and it virtually never breaks. Things just shouldn't be more complicated than necessary.

See it, hear it, feel it

For maximum usability, our equipment also gives you feedback from several senses: Look at a knob and SEE the current setting. Grab it and FEEL the notch. Turn it and you both FEEL and HEAR the clicks. So, even in tough, stressful environments you don't have to look twice at the generator. You just know.



Durable outlets - for your safety

Our lamp outlets combine ease of use with extreme durability and safety. Connection and locking of the plug requires very little force. Still, when fastened, you can literally use the cable for towing the generator (though it's not advisable...). Connect or disconnect the plugs at anytime!



Rubber handles - for easy handling

Your hands might be sweaty, dirty or sticky. Still you mustn't drop the equipment, even when things are messy. That's why we put sturdy, ergonomic rubber handles on top of our generators.



No-fuss knobs - for your fingers

The knobs on our generators are big and well-shaped, with a coloured notch and large, indented figures. When turned there's a distinct clicking. It's just simple, sturdy and easy to use.

Digital Wireless Freedom (Optional)

Digital Wireless Freedom is a system of professional photographic products, which incorporate a compatible digital radio system, which eliminates the need for a PC sync cable.

Originally integrated in the Profoto Acute2R generator, digital wireless freedom is taken to a whole new level with the Pro-B2 and AcuteB. Full 32 channel/4 zone triggering offers photographers creativity and control with a new simplified interface. The Pro-B2 and AcuteB is available with a receiver capable of firing the pack under any condition.

With an effective range of 100 m, the digital radio system cannot be fooled by other strobes firing, shaded, darkened studios or blinded by bright lights. Furthermore, since it works on a radio frequency and not infrared, it works around corners and through walls. Digital reliability ensures your flash fires every time.

Channel selection/features

There is a special dial for setting the first 4 radio channels (Pro-B2) or a special learn mode to set the channels.

It also offer additional features like precision delay, rear curtain synch and multi-pops. On top, radio slaves are faster than most IR transmitters – important when working with a fast recycling generator like Pro-B2.

Fully compatible with all 32 channels used by Pocket Wizard, the new Pro-B2 and AcuteB can be fired using any model PocketWizard transmitter or transceiver. You can also use the Sekonic L-358, L-608 or L-558 light meters, with the Pocket Wizard transmitter enabled, to fire the generator.

Available in two versions for Europe (433 Mhz) and other markets (344 Mhz).



Accessories



Pro-B Universal power adapter

With the snap-on universal power adapter, the Pro-B2 or the Pro-7b can be used as a regular studio generator. At the same time, the generator is quickly recharged, loading an empty battery in just 2.5 hours. The adapter accepts a wide range of input voltages: 12-24 V or 90-240 V.



Charging the AcuteB 600/600R

The Charger 1A (included with all AcuteB 600/600R generators) can recharge an empty battery in 5 h. The Charger 2A is twice as fast. The 85W Adapter will also let you use the modeling light in the studio, without using the energy from the battery.



AcuteB 600 Kit Bag

33 02 08

A rugged, nylon bag for an AcuteB 600/600R with lamp head and an extra battery cassette. With shoulder strap and handle.

Pro-B Protective Bag

34 02 02

A rugged, nylon bag for a Pro-B2 or a Pro-7b, with shoulder strap and handle. Perfect transportation or protection on location.



Profoto – The Light Shaping Company

For over three decades, professional photographers all over the world have come to value Profoto's expertise in lighting. Profoto's extensive range of Light Shaping Tools offers photographers countless possibilities for creating, regulating and adjusting their own light.

Profoto is also the world leader in rental equipment. Profoto's professional products can be purchased or rented at professional photo shops, rental studios and rental shops everywhere, from Paris, London and Milan to New York City, Shanghai, Tokyo and Cape Town.

Most of the world's top photographers have chosen to work with products from Profoto, no matter if they're using flash or continuous light (HMI or tungsten). Some photographers even claim they can tell, only from seeing a picture, if Profoto equipment has been used.

If you want to know why, start by looking into this brochure. In here, we've gathered everything that makes Profoto and our products special. If you would like more detailed information, don't hesitate to contact us.



The Light Shaping Company

Profoto AB,
Box 2023, SE 128 21 Skarpnäck (Stockholm), Sweden. Phone + 46 (0)8-4475300, Fax + 46 (0)8-4475320.
Email info@profoto.se – www.profoto.com