

PARABODY®

216 50 LB. ADD-ON KIT

WARNING:

Read and follow all directions for each step to insure proper assembly of this product.

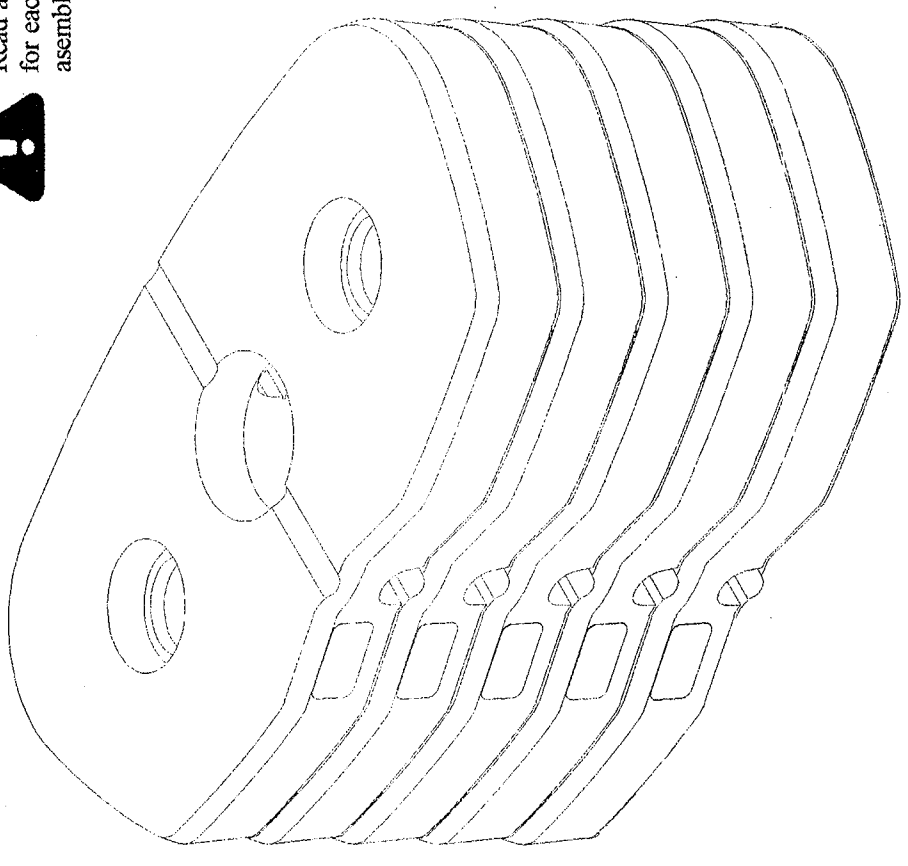

ASSEMBLY INSTRUCTIONS

CLASS H
PART # 7016801
REV. B

STEP 6:

- Assemble the WEIGHT STACK PIN to the 20 HOLE WEIGHT STACK SHAFT as shown.
- Screw the WEIGHT STACK CABLE into the 20 HOLE WEIGHT STACK SHAFT of the HEAD PLATE until the CABLE slightly pulls on the HEAD PLATE.
- **TIGHTEN** cable jam nut securely!
- **CAREFULLY** assemble and **SECURELY** tighten any previously removed or loosened bolts in the TOP BOOM to allow the GUIDE RODS to be secured. Refer to the GYM ASSEMBLY INSTRUCTIONS.

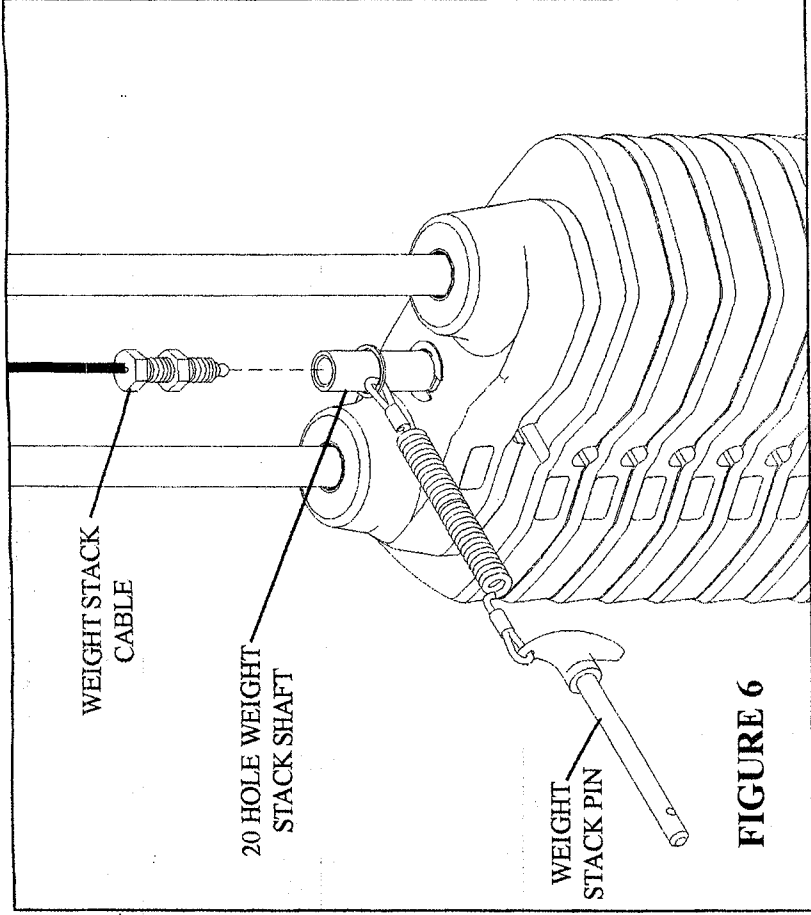

FIGURE 6

Thank you for purchasing the Parabody 216101 50 LB. ADD-ON KIT. If unsure of proper use of equipment, call your local LifeFitness distributor or call the Parabody customer service department at (800) 328-9714.

PARTS LIST

KEY	PART #	DESCRIPTION	QTY	KEY	PART #	DESCRIPTION	QTY
1	6939201	WEIGHT PLATE	5	3	6978101	WEIGHT STACK LABEL	1
2	7095801	WEIGHT STACK SHAFT	1	4	6382301	WEIGHT PLATE BUSHINGS (10 CT)	1

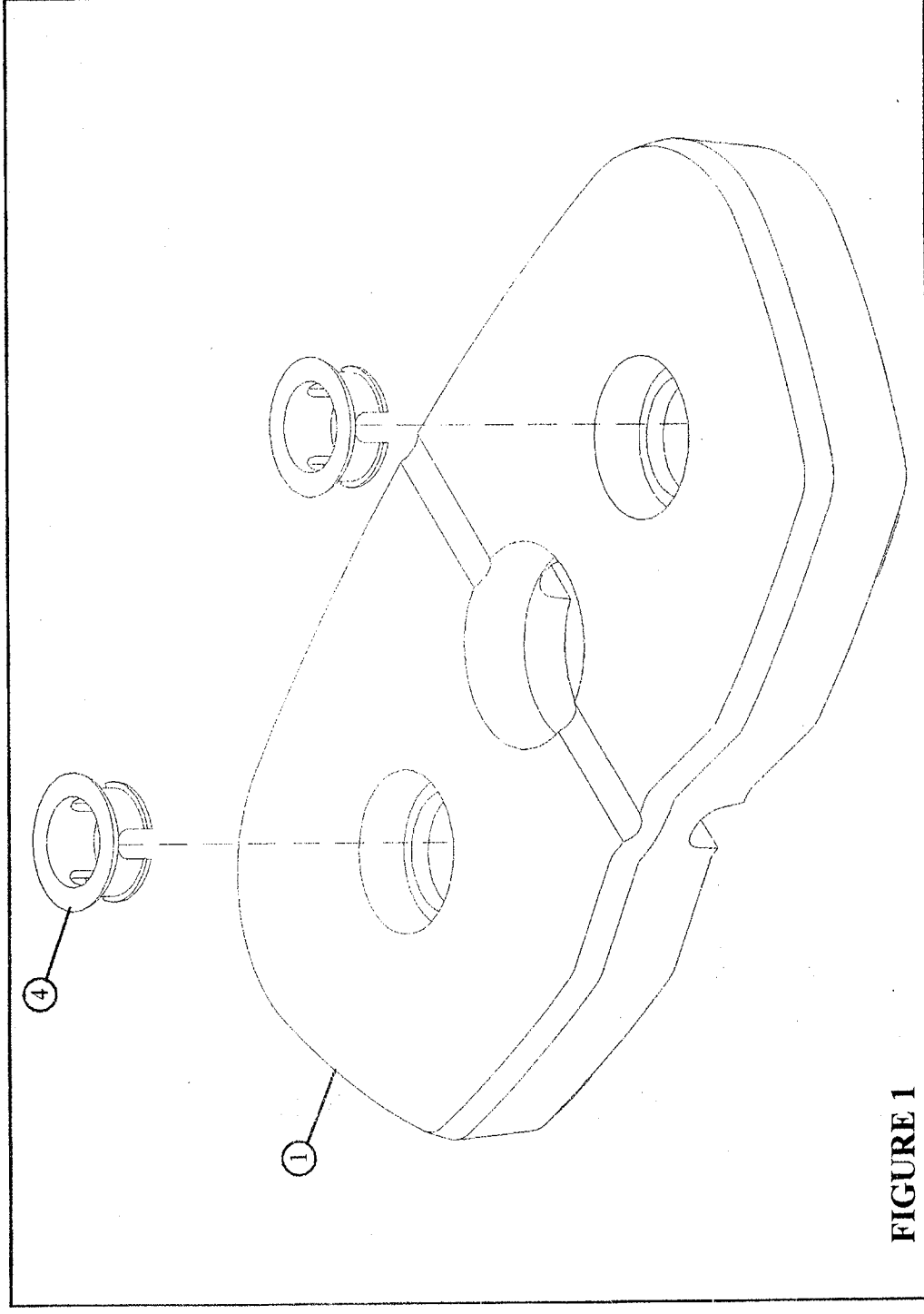

FIGURE 1

STEP 1:

- Insert two WEIGHT PLATE BUSHINGS (4) into each of the five WEIGHT PLATES (1) as shown in FIGURE 1.

STEP 2:

- Unscrew the WEIGHT STACK CABLE from the 15 HOLE WEIGHT STACK SHAFT as shown in FIGURE 2.
- Remove the WEIGHT STACK PIN from the 15 HOLE WEIGHT STACK SHAFT as shown.

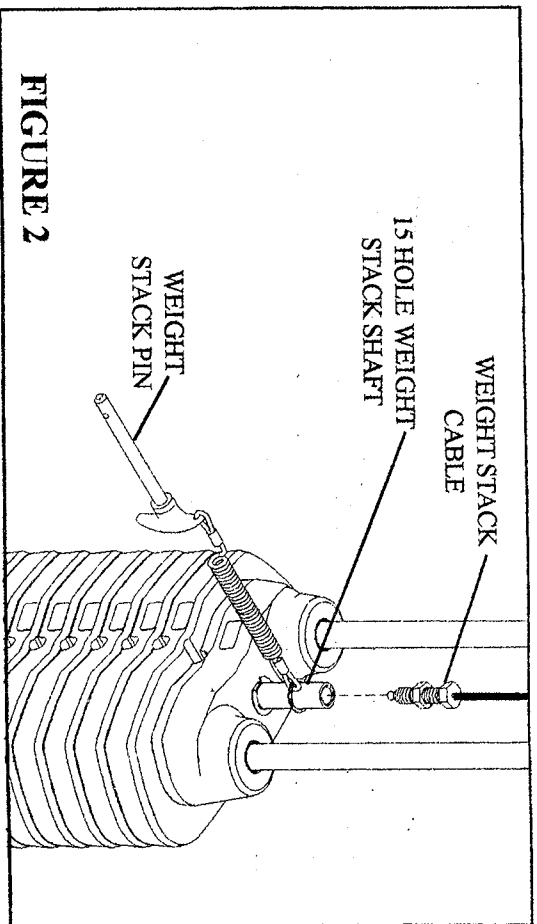

FIGURE 2

STEP 3:

- CAREFULLY remove or loosen bolts in the TOP BOOM to allow the GUIDE RODS to be tilted. Refer to the GYM ASSEMBLY INSTRUCTIONS.

Put the GUIDE RODS back and remove the SHAFT COLLARS, HEAD PLATE ASSEMBLY, fifteen WEIGHT PLATES, two WEIGHT STACK CUSHIONS, two 3/4" WASHERS, and two WEIGHT STACK SPACERS as shown in FIGURE 3. (NOTE: Please discard the two 3/4" WASHERS, and the two WEIGHT STACK SPACERS.)

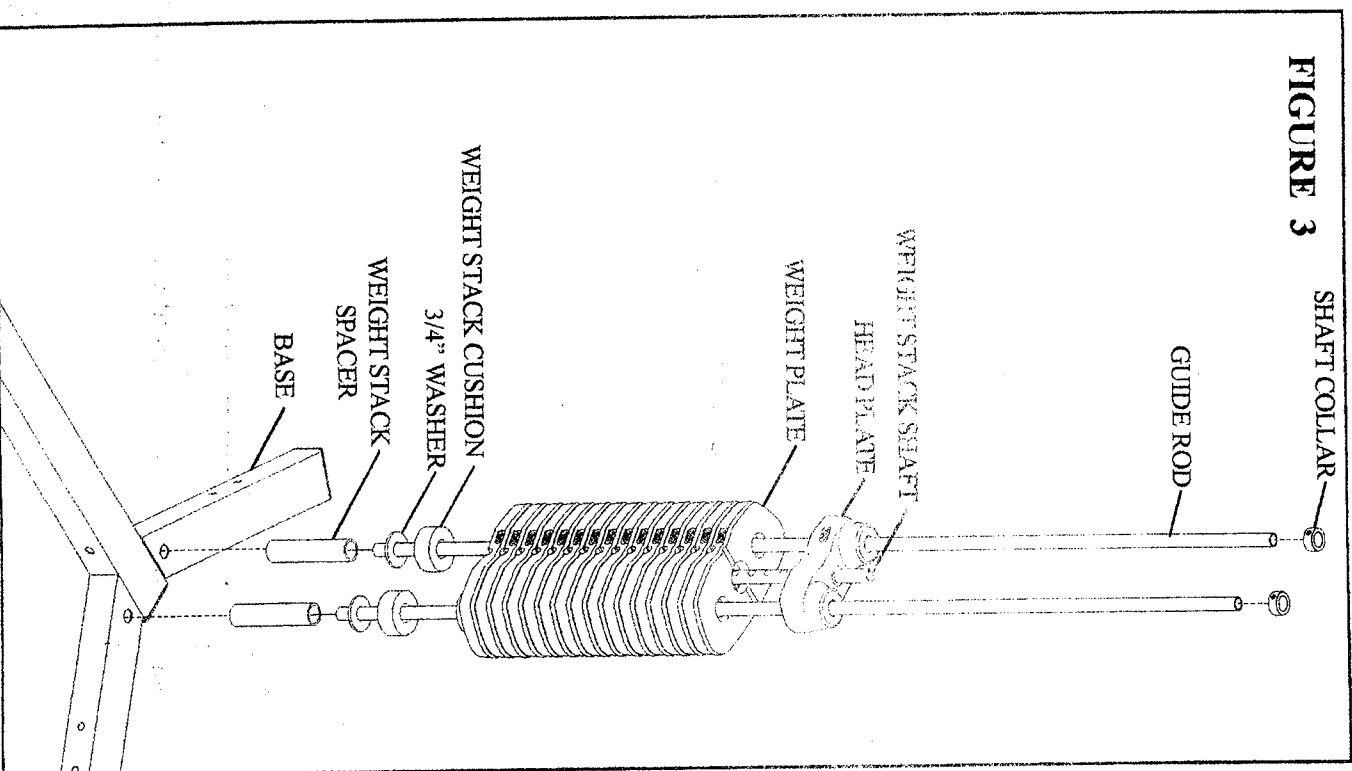

FIGURE 3

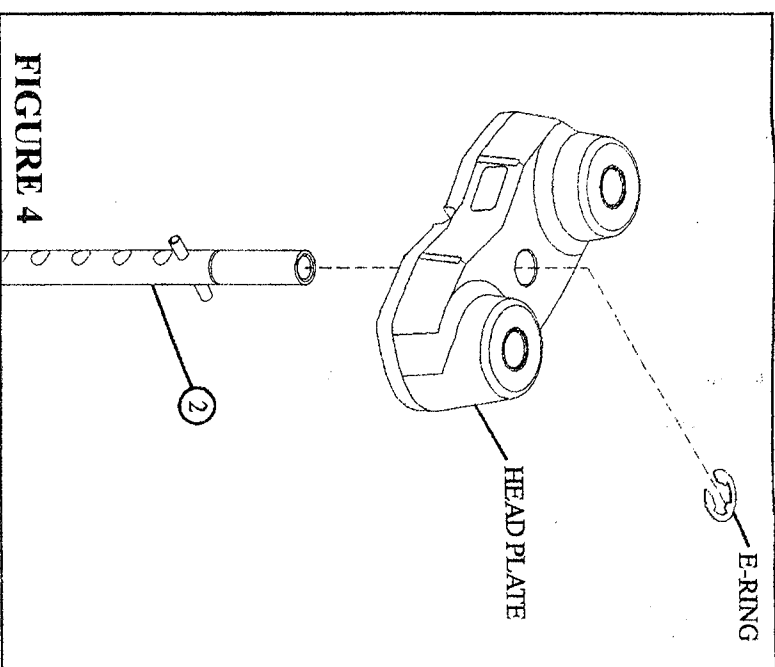

FIGURE 4

STEP 4:

- Remove the E-RING and the old WEIGHT STACK SHAFT from the HEAD PLATE. (NOTE: Please discard the old WEIGHT STACK SHAFT)
- Slide the new 20 HOLE WEIGHT STACK SHAFT (2) thru the hole in the HEAD PLATE and lock in place using the previously removed E-RING as shown in FIGURE 4.

STEP 5:

- Insert the two GUIDE RODS through the two WEIGHT STACK CUSHIONS into the base as shown in FIGURE 5.
- Lubricate the GUIDE RODS with a silicon or teflon spray that is available at most hardware stores.
- USING EXTREME CARE, slide the five new WEIGHT PLATES (1) and the previous fifteen WEIGHT PLATES down over the GUIDE RODS onto the WEIGHT STACK CUSHIONS. (NOTE: Make sure that the key holes of the WEIGHT PLATES all face the same way.)

- Carefully slide the new HEAD PLATE ASSEMBLY and the SHAFT COLLARS down over the GUIDE RODS onto the weight stack as shown in FIGURE 5.

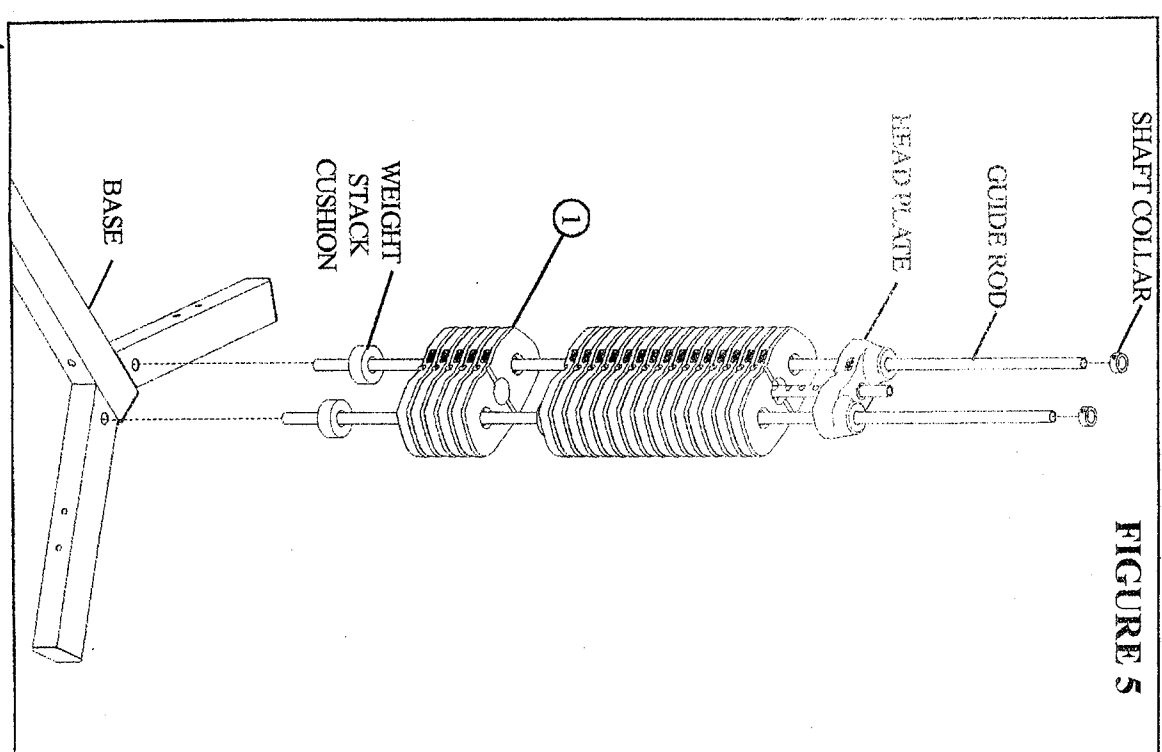

FIGURE 5