

CARBON MONOXIDE ALARM

BRK[®]

THE PROFESSIONAL STANDARD

CAT. **C0614B**



DIGITAL DISPLAY

Convenient display offers visual confirmation and remembers highest CO levels detected.

ELECTROCHEMICAL CO SENSOR

Most accurate technology available for detecting carbon monoxide as compared to other sensing technologies.

TWO SILENCE FEATURES

Silences low battery chirp for up to eight hours or silence nuisance alarm for several minutes.

9V BATTERY BACKUP

Alkaline battery backup.

120V AC, 60Hz Plug-in with 9V Battery Backup

Description:

The First Alert/BRK Cat. No. C0614B direct plug-in, 120V AC, 60Hz single station carbon monoxide alarm is specifically designed for residential and institutional applications including sleeping rooms of hospitals, hotels, motels, dormitories and other multi-family dwellings. Model C0614B complies with UL2034 and other agencies that model their codes after the above agencies. Model C0614B meets code where plug-in AC/DC carbon monoxide alarms are allowed.

The C0614B features an electrochemical CO sensor, an 85dB horn, a single button for test/silence and an LED power indicator. The low power warning indicator will cause the alarm to "chirp" when the batteries need replacing. This alarm has two silence features. Low Battery Silence: Temporarily silence the low battery chirp for up to eight hours. Alarm Silence: Silence alarm for several minutes. The C0614B also features a digital display that shows visual confirmation of CO levels and has Peak Level Memory, remembers and displays the highest levels detected when the multi-function button is pressed. The C0614B is designed to be plugged directly into a standard non-switched outlet.



CAT. C0614B

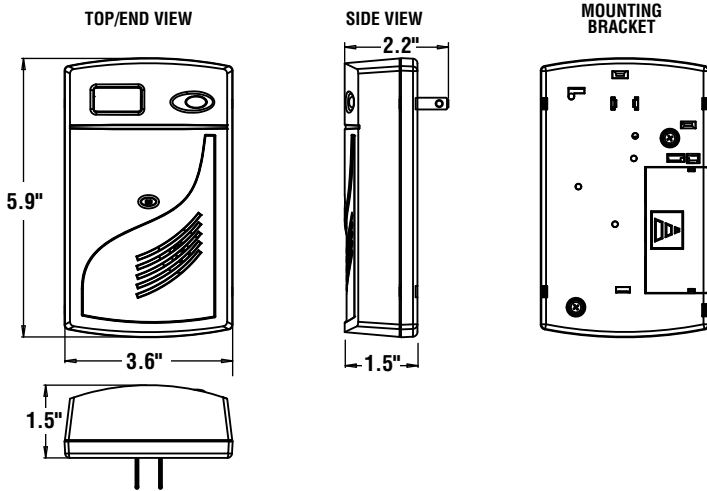

TECHNICAL SPECS

Alarm Dimensions:	5.9" H x 3.6" L x 1.5" D
Weight:	6.5 oz
Operating Voltage:	120V AC 60Hz w/ 9V battery backup
Operating Current:	.09 amps (standby/alarm)
Temperature Range:	40°F (4°C) to 100°F (38°C)
Humidity Range:	10% to 95% relative humidity (RH)
Audio Alarm:	85dB at 10 feet
Test/Silence:	Electronically simulates carbon monoxide condition, causing the unit to alarm Press and hold test/silence button
Alarm Reset:	Automatic when CO clears
Interconnections:	Up to 18 units of First Alert or BRK Smoke, CO and Heat Alarms. Maximum of 12 smoke alarms. See user's manual for details.
CO Sensor:	Electrochemical
Indicator Lights/Sounds:	AC Power: Constant Red LED, Display: blank DC Power: Intermittent Red LED, Display: "bAt" Local Alarm: Red LED flashes rapidly, Display: CO level in PPM
Listing:	Listed to UL2034 Standard

ARCHITECTURAL AND ENGINEERING SPEC

The carbon monoxide alarm shall be a BRK Model C0614 and shall provide at a minimum the following features and functions:

1. An electrochemical CO sensor and an LCD multifunction digital display with peak CO level memory capability.
2. Powered by 120V AC, 60Hz and have a monitored 9V battery backup and a solid state piezo horn rated at 85dB at 10 ft. and shall be capable of self restoring.
3. The unit shall perform self diagnostic tests and issue a malfunction warning both audibly (three chirps) and visually ("Err" in display) if the unit malfunctions.
4. A visual LED power-on indicator to confirm unit is receiving power or to confirm unit has switched to battery backup mode. In battery backup mode, digital display indicates "bAt"; "bAt" indication will flash if battery is weak or missing.
5. The CO sensor is adjusted not to detect CO levels below 30 PPM and will not alarm when exposed to constant levels of 30 PPM for 30 days. It will alarm at the following levels: 400 PPM CO between 4 and 15 minutes, 150 PPM CO between 10 and 50 minutes and 70 PPM CO between 60 and 240 minutes.
6. A test/silence button to check all alarm functions and to silence any nuisance alarms. In addition, the unit shall have a low battery silence feature to quiet the low battery chirp for up to eight hours.
7. The unit shall be capable of operating between 40°F (4°C) and 100°F (38°C) and relative humidity between 10% and 95%.
8. The unit shall at a minimum meet the requirements of UL2034, NFPA 720 and ICC.

SHIPPING SPECS:

Individual Carton Dimensions	6.81" L x 3.99" W x 2.38" H
Weight	0.61 lbs.
Cube	0.037 ft3
UPC	0 29054 00382 9
Master Carton Dimensions	7.69" L x 7.31" W x 7.38" H
Master Pack	6
Weight	4.0 lbs.
Cube:	0.24 ft3
I2 of 5:	600 29054 00382 1
Pallet Information	
Cases per Layer	30
Number of Layers:	6
Cases per Pallet:	180
Units per pallet:	1,080
Cube:	49.3 ft3
Weight:	785 lbs.

INSTALLATION OF ALARM

Installation of this smoke alarm must conform to all local electrical codes and Article 760 of the National Electrical Code (NFPA 70) and NFPA 720.

THE PARTS OF THIS CO ALARM

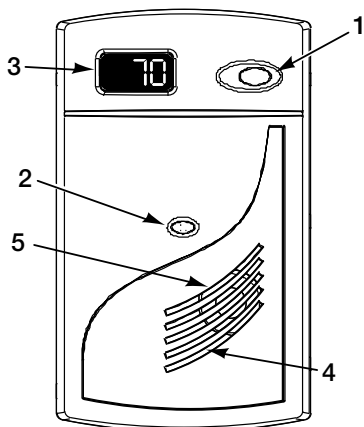

1. Test/Silence/Scroll Button
2. POWER/ALARM Light
3. Digital Display
4. Air Vents
5. Alarm Horn (under cover)



©2009 BRK Brands, Inc. a Jarden Corporation
Company (NYSE: JAH)
3901 Liberty Street Road
Aurora, IL 60504-8122
All rights reserved

First Alert is a registered trademark of the First Alert Trust
BRK is a registered trademark of BRK Brands, Inc.
CM2930