

CASSETTE TYPE AIR CONDITIONER

Indoor Unit Operation & Installation Manual

AB094FAAHA

AB124FAAHA

AB184FCAHA

AB244FCAHA

AB424FCAHA

AB484FCAHA

No.0010576722A

- Please read this operation manual before using the air conditioner.
- Please keep this manual carefully and safely.

■ Contents

Cautions	1-5
Part name of the unit.....	6
Maintenance.....	7-9
Trouble Shooting	10-11
When Trouble Happens.....	12-13
Customer Need-to-know.....	14
Installation Procedure	15-25
Electrical Wiring.....	26-28
Technical Specification.....	29

■ Cautions

Disposal of the old air conditioner

Before disposing an old air conditioner that goes out of use, please make sure it's inoperative and safe. Unplug the air conditioner in order to avoid the risk of child entrapment.

It must be noticed that air conditioner system contains refrigerants, which require specialized waste disposal. The valuable materials contained in a air conditioner can be recycled. Contact your local waste disposal center for proper disposal of an old air conditioner and contact your local authority or your dealer if you have any question. Please ensure that the pipework of your air conditioner does not get damaged prior to being picked up by the relevant waste disposal center, and contribute to environmental awareness by insisting on an appropriate, anti-pollution method of disposal.

Disposal of the packaging of your new air conditioner

All the packaging materials employed in the package of your new air conditioner may be disposed without any danger to the environment.

The cardboard box may be broken or cut into smaller pieces and given to a waste paper disposal service. The wrapping bag made of polyethylene and the polyethylene foam pads contain no fluorochloric hydrocarbon.

All these valuable materials may be taken to a waste collecting center and used again after adequate recycling.

Consult your local authorities for the name and address of the waste materials collecting centers and waste paper disposal services nearest to your house.

Safety Instructions and Warnings

Before starting the air conditioner, read the information given in the User's Guide carefully. The User's Guide contains very important observations relating to the assembly, operation and maintenance of the air conditioner.

The manufacturer does not accept responsibility for any damages that may arise due to non-observation of the following instruction.

- Damaged air conditioners are not to be put into operation. In case of doubt, consult your supplier.
- Use of the air conditioner is to be carried out in strict compliance with the relative instructions set forth in the User's Guide.
- Installation shall be done by professional people, don't install unit by yourself.
- For the purpose of safety, the air conditioner must be properly grounded in accordance with specifications.
- Always remember to unplug the air conditioner before opening inlet grill. Never unplug your air conditioner by pulling on the power cord. Always grip plug firmly and pull straight out from the outlet.

■ Cautions

- All electrical repairs must be carried out by qualified electricians. Inadequate repairs may result in a major source of danger for the user of the air conditioner.
 - Do not damage any parts of the air conditioner that carry refrigerant by piercing or perforating the air conditioner's tubes with sharp or pointed items, crushing or twisting any tubes, or scraping the coatings off the surfaces. If the refrigerant spurts out and gets into eyes, it may result in serious eye injuries.
 - Do not obstruct or cover the ventilation grille of the air conditioner. Do not put fingers or any other things into the inlet/outlet and swing louver.
 - Do not allow children to play with the air conditioner. In no case should children be allowed to sit on the outdoor unit.
4. The wiring method should be in line with the local wiring standard.
 5. The power cable and connecting cable are self-provided. The requirement of the power cable: **H05RN-F 3G 1.5mm²**
The requirement of the connecting cable: **H05RN-F 2 i (1.0~1.5)mm²**
All the cables shall have got the European authentication certificate.
 6. The breaker of the air conditioner should be all-pole switch; and the distance between its two contacts should be no less 3mm. Such means for disconnection must be incorporation in the fixed wiring.
 7. The waste battery shall be disposed properly.
 8. The indoor unit installation height is at least 2.5m.

Specifications

The refrigerating circuit is leak-proof.

The machine is adaptive in following situation

1. Applicable ambient temperature range:

			Rated	Maximum	Minimum
Cooling	Indoor	DB °C	27	32	21
		WB °C	19.5	23	15
	outdoor	DB °C	35	43	21
		WB °C	24	26	15
Heating	Indoor	DB °C	20	27	20
		WB °C	15	15	15
	outdoor	DB °C	7	21	-10
		WB °C	6	15	--

2. If the supply cord is damaged, it must be replaced by the manufacturer or its service agent or a similar qualified person.
3. If the fuse on PC board is broken please change it with the type of T 3.15A/250VAC.

■ Cautions

Safety cautions

Carefully read the following information in order to operate the airconditioner correctly.

Below are listed three kinds of Safety Cautions and Suggestions.

WARNING! Incorrect operations may result in severe consequences of death or serious injuries.

CAUTION! Incorrect operations may result in injuries or machine damages; in some cases may cause serious consequences.

INSTRUCTIONS: These information can ensure the correct operation of the machine.

Be sure to conform with the following important Safety Cautions.

The Safety Cautions should be at hand so that they can be checked at any time when needed.

If the conditioner is transferred to the new user, this manual should be as well transferred to the new user.

WARNING!

- **Don't blow the human body with the cooling air too long, and don't let the room temperature decrease too low either.**

Otherwise the one will feel unpleasant or harm ones' health.



- **If any abnormal phenomena is found (e. g. smell of firing), please cut off the power supply immediately, and contact the dealer to find out the handling method.**

In such case, to continue using the conditioner will damage the conditioner, and may cause electrical shock or fire hazard.



- **When need maintenance and repairment, call dealer to handle it.**

Incorrect maintenance and repairment may cause water leak, electrical shock and fire hazard.

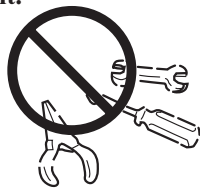

- **Please let the dealer be responsible for installing the conditioner.**

Incorrect installation may cause water leak, electrical shock and fire hazard.

- **Don't put fingers or any other things into the inlet/outlet and swing louver while the conditioner is in operation.**

Because the highspeed fan is very dangerous and may cause injuries.



- **Call the dealer to take measures to prevent the refrigerant from leaking.**

If conditioner is installed in a small room be sure to take every measure in order to prevent suffocation accident even in case of refrigerant leakage.

- **When conditioner is deinstalled or reinstalled dealer should be responsible for them.**

Incorrect installation may cause water leaking, electrical shock and fire hazard.

■ Cautions

CAUTIONS!

- **Conditioner should not be used for any other purpose other than airconditioning.**

Don't use air-conditioner for any other special purposes, e.g. the preservation and protection of food, animals, plants, precision apparatus as well as work of art, otherwise the qualities of these stuffs may be damaged.



- **Don't dismantle the outlet of the outdoor unit.**

The exposure of fan is very dangerous which may harm human beings.



- **When air-conditioner is co-used with other heat-radiator the frequent replacement of room atmosphere should be required.**

Inefficient ventilation may cause suffocation.



- **After a long time use of air-conditioner the base should be checked for any damages.**

If the damaged base is not repaired, the unit may fall down and cause accidents.



- **No goods or nobody is permitted to placed on or stand on outdoor unit.**

The falling of goods and people may cause accidents.



- **Pets and plants should not be blown directly in the air flow.**

Otherwise will suffer damage.



- **Don't operate the air-conditioner with damp hands.**

Otherwise will be shocked.



- **Only use correctly-typed fuse.**

May not use wire or any other materials replacing fuse, otherwise may cause faults or fire accidents.



- **Don't place any burning unit in the air flow of air-conditioner, which may cause incomplete combustion.**



- **No inflammable spray fluid should be permitted to be placed or used near to air-conditioner otherwise may cause fire accidents.**



- **Air-conditioner should be cleaned only after power supply is cut off to keep from shock or hurt.**



- **Don't clean air-conditioner with water.**

Otherwise may cause shock.



- **When use the fumigating insecticide don't open air-conditioner.**

Otherwise the poisonous chemicals may settle in air-conditioner which harm the health of chemical-allergic people.



■ Cautions

Installation

Please ask the dealer or specialist to install, never try by the users themselves. After the installation please be sure of the following conditions.

WARNING !

- **Please call dealer to install the air-conditioner.**
Incorrect installation may cause water leaking, shock and fire hazard.

CAUTION !

- **Air-conditioner can't be installed in the environment with inflammable gases because the inflammable gases near to air-conditioner may cause fire hazard.**
- **Installed electrical-leaking circuit breaker.**
It easily cause electrical shock without circuit breaker.
- **Connect earthing wire.**
Earthing wire should not be connected to the gas pipe, water pipe, lightning rod or phone line, incorrect earthing may cause shock.  Earthing
- **Use discharge pipe correctly to ensure efficient discharge.**
Incorrect pipe use may cause water leaking.

[Location]

- Air-conditioner should be located in well-vented and easily-accessible place.
- Air-conditioner should not be located in the following places:
 - (a) Places with machine oils or other oil vapours.
 - (b) Seaside with high salt content in the air.
 - (c) Near to hot spring with high content of sulfide gases.
 - (d) Area with frequent fluctuation of voltage e.g. factory, etc.
 - (e) In vehicles or ships.
 - (f) Kitchen with heavy oil vapour or humidity.
 - (g) Near to the machine emitting electric-magnetic waves.
 - (h) Places with acid, alkali vapour.
- TV, radio, acoustic appliances etc are at least 1 m far away to the indoor unit, outdoor unit, power supply wire, connecting wire, pipes, otherwise images may be disturbed or noises be created.

- As required, take measures against heavy snow.

[Wiring]

- Air-conditioner should be equipped with special power supply wire.

[Operating noise]

- Choose the following locations:
 - (a) Capable of supporting air-conditioner weight, don't increase operating noise and vibration.
 - (b) Hot vapour from outdoor unit outlet and operating noise don't disturb neighbour.
- No obstacles around the outdoor unit outlet.

■ Introduction to Spare Parts

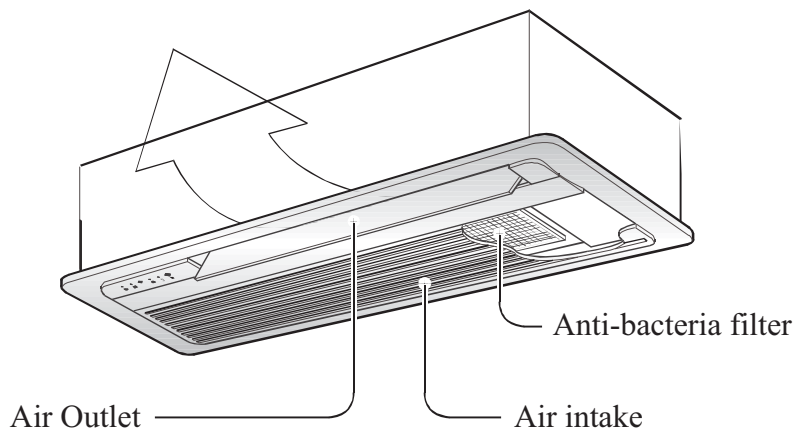
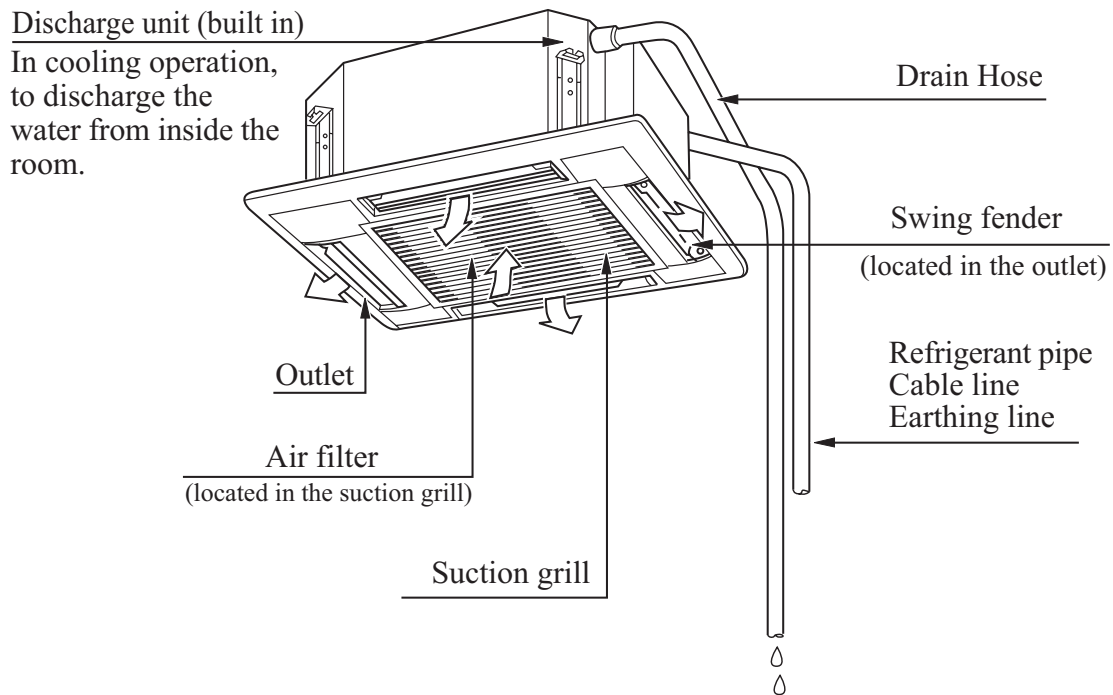

Maintenance

[Clean air filter]

NOTE When having to clean, don't dismantle air-filter, otherwise may cause faults. In the environment where there is too much dust, air filter should be cleaned for more times. (about half a year one time)

1. Open inlet grill

Press the elliptical "PUSH" knob, the inlet grill will automatically drop. (the inlet grill is caught with two pothooks)

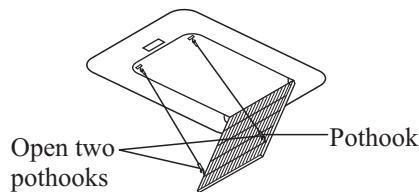
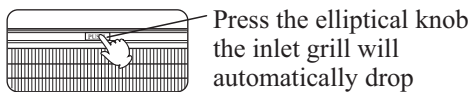

2. Open two othooks

3. Dismantle air filter

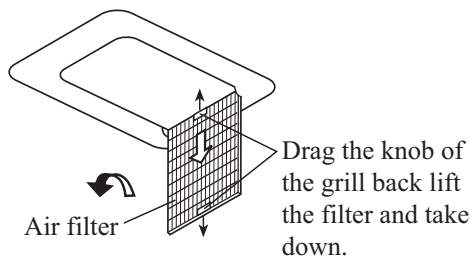

4. Clean

CAUTION!

- Don't wash with water over 50°C, to prevent discoloring or deforming.
- Don't dry over fire. Filter maybe burn.

(A) Remove dust with vacuum filter.

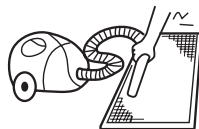

(B) Wash with water.

With too much dust, use soft brush and neutral detergent.

Swing off the water, and then place in cool place.

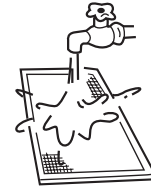

5. Install air filter

(1) Put filter into protruding parts at the top of the inlet grill.

(2) Connect the two pothooks with inlet grill See 2

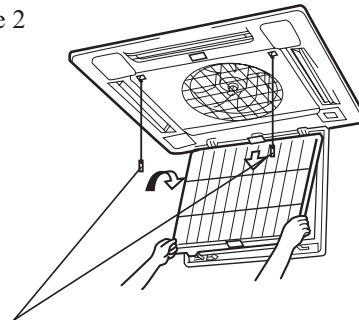

Connect the two pothooks with inlet grill

6. Close inlet grill See 1.

[Clean inlet grill]

1. Open inlet grill

- Press the elliptical "PUSH" knob, the inlet grill will automatically drop. (the inlet grill is caught with two pothooks)

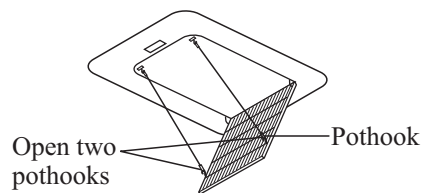
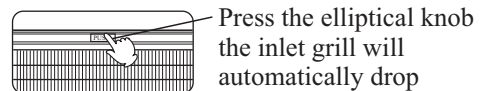

Maintenance

2. Take off airfilter

See "clean air filter"

3. Take of inlet grill

Open the inlet grill by an angle of 45°, lift up.

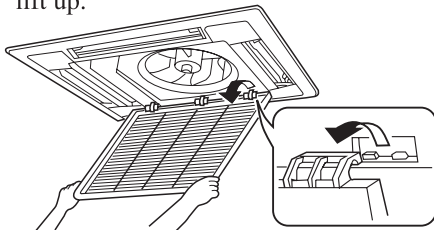

4. Clean

CAUTION!

- Don't wash with water over 50°C, to prevent decoloring or deforming.
- Use soft brush, water and neutral detergent, then swing off the water.



NOTE

When the filter too much dust

- To spray the special detergent for vent fan or utensils.

5. Install inlet grill see 3

6. Install air filter see "Clean air filter"

7. Close inlet grill see 1

[Clean outlet and shell]

CAUTION!

- Don't use gasoline, benzene, dilutant, polishing powder, or liquid insecticide.

- Don't wash with water over 50°C, otherwise may cause decoloring or deforming.
- Use soft dry cloth to scrub.
- If dust not removed, can use water or neutral detergent.
- If ceiling built-in conditioner's swing plate too dirty, it can be dismantled (as described below) and cleaned.

[Dismantle and install swing plate]

1. Fix the swing plate at the bottom.
2. Dismantle the swing plate.

CAUTION!

- Use water to clean the plate and don't heavily scrub, otherwise the fine hair may fall off. Unscrew the screw at both ends of the swing plate.

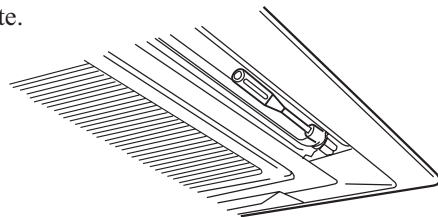

[Dismantle and install swing plate]

3. Install swing plate

Lightly rotate swing plate to insert the ridge at both ends of the outlet into the groove and then screw up.

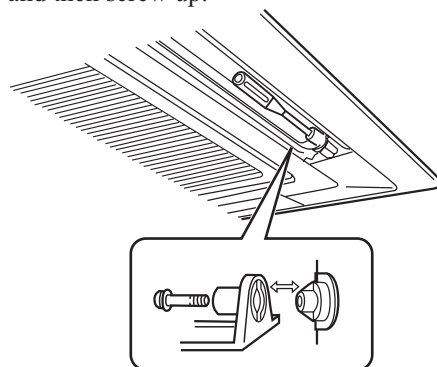

Maintenance

Seasonal Reserve

Post-season Care

Operate the unit with FAN mode on a fair day for about half a day to dry the inside of the unit well.

Stop operation and turn off the power supply switch .Electric power is consumed even the air conditioner is in stop.

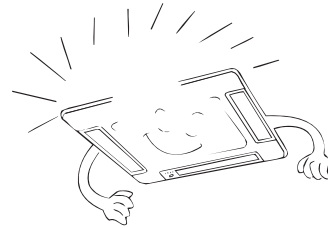

Clean the air filter, indoor unit and outdoor unit,and cover the unit with dustcoat.

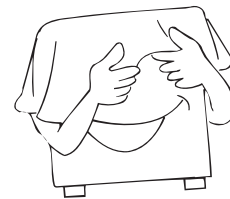

Pre-season Care

See that there is no obstacles blocking the air inlet and air outlet of both indoor and outdoor unit to avoid reduce the working efficiency.

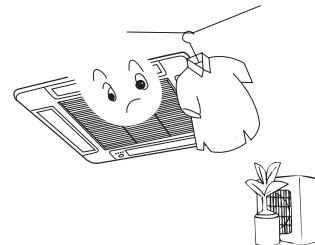

Be sure to install the air filter, ensure that the air filter is not dirty. Otherwise may result in machine damages or cause malfunction due to dust inside the unit

To prevent compressor when start in HEAT mode, please cut in the power supply switch 12 hours before starting run,furthermore, always keep the power supply switch on during the using senson.

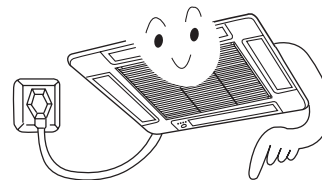



NOTE

1. **The inner part of indoor unit must be cleaned. Consult dealer, because clean must be done by technician.**
2. **In cooling operation, discharging system discharge water in room.**

■ Trouble Shooting

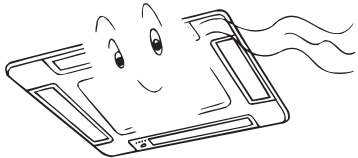
The followings are not malfunction

<p>Water flowing sound is heard</p> 	<p>When the air conditioner is started, when the compressor starts or stops during operation or when the air conditioner is stopped, it sometimes sounds □ Bi- Bi-□ or □Godo-Godo□. It is the flowing sound of the refrigerant, not a malfunction.</p>
<p>Cracking sound is heard</p>	<p>This is caused by heat expansion or contraction of plastics</p>
<p>It smells.</p>	<p>Air blown out from the indoor unit sometimes smells. The smell results from smells of furniture, paint, tobacco absorbed by indoor unit.</p>
<p>During operation, white fog comes out of indoor unit.</p> 	<p>When in COOL or DRY mode, a thin water fog can be seen blown out of unit, this is the condensed fog because the suddenly cooled indoor air is blown out.</p>
<p>Automatically switch into FAN mode during cooling.</p>	<p>To prevent frost from being accumulated on the indoor unit heat exchanger, it sometimes automatically switched into the FAN mode, but it will soon back to the cooling mode.</p>
<p>The air conditioner cannot be restarted soon after it stops. Air conditioner does not start?</p> 	<p>This is because of the self-protection function of the system, therefore, it cannot be restarted for about three minutes after it stops.</p> <p style="text-align: center;">Please wait for three minutes</p>

■ Trouble Shooting

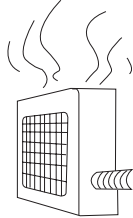
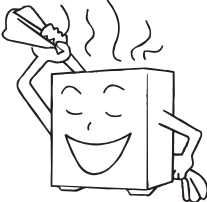

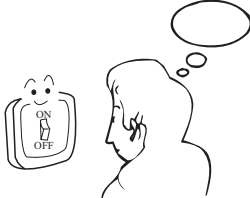

<p>Air does not blow or the fan speed cannot be changed during drying.</p>	<p>In DRY mode, when room temperature becomes 2°C higher than temperature setting, unit will run intermittently at LO speed regardless of FAN setting</p>
<p>Water or vapor generated from the outdoor unit during heating.</p> 	<p>This happens when the frost accumulated on the outdoor unit is removed (during defrosting operation).</p> <p>Defrosting operation</p> 
<p>During heating, indoor fan is still running even unit is stopped.</p>	<p>To get rid of the excess heat, indoor fan will continue running for a while after unit automatically stops.</p>

Please check the following things about your air conditioner before making a service call.

Unit fails to start.		
<p>Is the power supply switch on ?</p>  <p>Power supply switch is not in ON position.</p>	<p>Is city supply power normal ?</p> 	<p>Is the earth leakage breaker in action ?</p> <p>Be sure to turn off the power supply switch immediately and contact the sales dealer.</p>

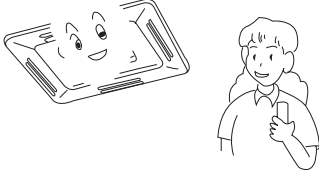
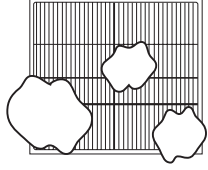
■ When Trouble Happens

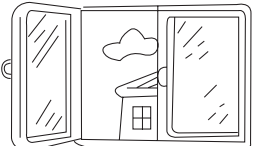
Insufficient cooling or heating

<p>The operation controller adjusted as required</p> 	<p>Air filter too dirty ?</p> 	<p>Horizontal swing louver upward ? (in HEAT mode)</p> 
<p>Any obstacle exists at the air inlet or outlet?</p> 	<p>Door or window left opened ?</p> 	

Insufficient cooling

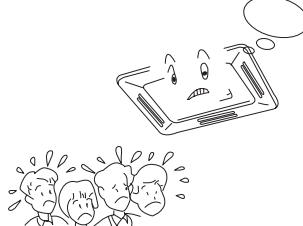
<p>Any other heat sources in the room?</p> 	<p>Sunlight direct into the room ?</p> 	<p>Too crowded in the room ?</p> 
--	--	---

Cooled air blown out (when heating)

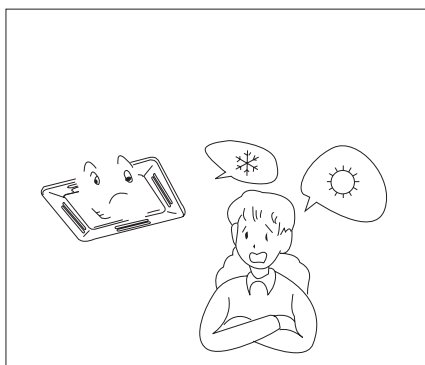

When the air conditioner does not operate properly after you have checked the above-mentioned items or when following phenomenon is observed, stop the operation of the air conditioner and contact your sales dealer.

- 1)The fuse or breaker often shuts down.
- 2)Water drops off during cooling or drying operation.
- 3)There is an irregularity in operation or abnormal sound that is audible.

When Trouble Happens

1. Error display

Indoor unit malfunction display code

Indoor unit malfunction	Display code	Indoor unit malfunction	Display code
Float switch or water motor abnormal	E0	The communication with electronic expansion box is abnormal	E7
Outdoor unit abnormal	E1		
Liquid temperature sensor is abnormal	E3	The communication between the wire remote controller and indoor unit control board is abnormal	E8
Gas temperature sensor is abnormal	E4		
Indoor unit address abnormal (Firstly you saw E5 in controller LCD, and then the failure code is changed from E5 to E9)	E5	The communication between indoor and outdoor unit is abnormal	E9
		Water temp. sensor is abnormal (Only used for the twin energy source function)	E0
Indoor unit EEPROM data is abnormal	E6		

Remote controller Timer and Operation indicator malfunction code

When the unit running, Timer indicator flash stand for indoor unit malfunction

Timer indicator Flashing times	Indoor unit malfunction
Flashing once	The liquid tube temperature sensor is abnormal
Flashing twice	The gas tube temperature sensor is abnormal
Flashing 3 times	The environment temperature sensor is abnormal
Flashing 4 times	The communication with outdoor unit is abnormal
Flashing 5 times	The communication with the electronic expansion valve control board is abnormal
Flashing 10 times	Indoor unit PG fan motor is abnormal
Flashing 11 times	Indoor unit water overflow or float switch is abnormal
Flashing 12 times	Indoor unit EEPROM data is abnormal
Flashing 15 times	Water temp. sensor is abnormal (Only used for the twin energy source function)

Outdoor unit malfunction display code

When the wire remote controller display E1, Can check the outdoor unit control board LED1 or outdoor unit malfunction display code to sure outdoor unit malfunction.

When the operation indicator flashing stand for outdoor unit malfunction, Operation indicator flashing times can't determinant outdoor unit malfunction, You must check the outdoor unit control board LED1 flashing times or outdoor unit malfunction display code to sure outdoor unit malfunction.



Others malfunction manual please read the outdoor unit manual.

Please keep this manual carefully and safely.

Customer Need-to-know

Customer Need-to-know

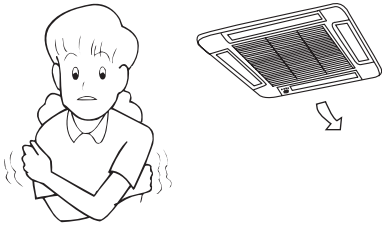
- Please install the air conditioner according to the requirements specified in this manual to ensure the air conditioner work well.
- Be careful not to scratch the surface of the case during moving the air conditioner.
- Please keep the installation manual for future reference when maintenance and changing installation place.
- After installation ,please use the air conditioner according to the specification in the operation manual.

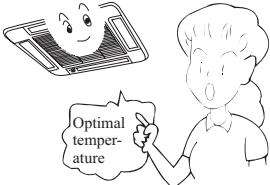
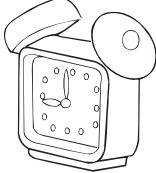
Using Directions	
<p>Adjust suitable airflow direction</p> 	<p>Avoid direct sunlight and airflow</p> 
<p>Keep the proper indoor temperature. Too cool or hot is not good for your health. Furthermore, it will result in excessive consumption of electric power.</p> 	<p>Effectively use timer. Using TIMER mode, you can make the room temperature reach a suitable temperature when you wake up or go back home.</p> 

ATTENTION: after finishing installation, confirm no refrigerant leakage.

Installation Procedure

Installation tools

The installation tools listed in the following sheet can be used as required.



1. Screw driver
2. Hacksaw
3. Drill with a diameter of 60mm
4. Inner hexagon spanner, shifting spanner
5. Spanner (14, 17, 19, 24, 27mm)
6. Pipe cutter
7. Pipe expander
8. Knife
9. Pincers
10. Leakage detector or soapy water
11. Band tape
12. Scraper
13. Refrigerant oil

Standard accessories

The following parts mentioned in this manual are the installation accessories we prepared.

Symbol	Parts Name
A	Adhesive tape
B	Pipe clamp
C	Connecting hose
D	Drainage hose
E	Non-hydroscopic heat insulating material
F	Gypsum powder

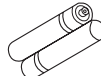
Following in the list are the accessories supplied with the unit, which can be used as required

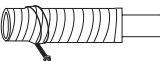
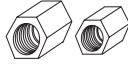
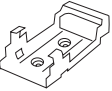
No.	Accessory parts	Qty.
①	 Remote controller	1
②	 Battery	2
③	 Wire clamp	4
④	 Heat insulation sheathing	1+1
⑤	 Accessories	1
⑥	 Screw cap	1+1
⑦	 Remote controller bracket	1

■ Installation Procedure

CAUTIONS: To ensure proper installation, read "Cautions" carefully before working. After installation, start the unit correctly and show customers how to operate and maintain the unit.

Meanings of Warning and Cautions:

Warning! Serious injury or even death might happen, if it is not observed.

Caution! Injury to people of damages to machine might happen, if it is not observed.

WARNING!

- Installation shall be done by professional people, don't install unit by yourself. Incorrect installation will cause water leakage, electric shock or fire.
- Install unit as per the Manual. Incorrect installation will cause water leakage, electric shock or fire accident.
- Be sure to use specified accessories and parts. Otherwise, water leakage, electric shock, fire accident or unit falling down may happen.
- Unit should be placed on a place strong enough to hold the unit. Or, unit will fall down causing injuries.
- When install the unit, take in consideration of storms, typhoon, earthquake. Incorrect installation may cause unit to fall down.
- All electric work shall be done by experienced people as per local code, regulations and this Manual.
- Use exclusive wire for the unit. Incorrect installation or undersized electric wire may cause electric shock or fire accident.
- All the wires and circuit shall be safe. Use exclusive wire firmly fixed. Be sure that external force will not affect terminal block and electric wire. Poor contact and installation may cause fire accident.
- Arrange wire correctly when connecting indoor and outdoor power supply. Fix terminal cover firmly to avoid overheat, electric shock or even fire accident.
- In case refrigerant leakage occurred during unit installation, keep a good ventilation in the room.
- Poisonous gas will occur when meet with fire.
- Check the unit upon installation. Be sure there is no leakage. Refrigerant will induce poisonous gas when meet heat source as heater, oven, etc.
- Cut power supply before touching terminal block.

CAUTION!

- Unit shall be grounded. But grounding shall not be connected to gas pipe water pipe, telephone line. Poor grounding will cause electric shock.
- Be sure to install a leakage breaker to avoid electric shock.
- Arrange water drainage according to this Manual. Cover pipe with insulation materials in case dew may occur. Unproper installation of water drainage will cause water leakage and wet your furniture.
- To maintain good picture or reduce noise, keep at least 1 m from T.V. radio, when install indoor and outdoor unit, connecting wire and power cable. (If the radio wave is relatively strong, 1 m is not enough to reduce noise).
- Don't install unit in following places:
 - (a) Oil mist or oil gas exists, such as kitchen, or, plastic parts may get aged, or water leakage.
 - (b) Where there is corrosive gas. Copper tube and welded part may be damaged due to corrosion, causing leakage.
 - (c) Where there is strong radiation. This will affect unit's control system, causing malfunction of the unit
 - (d) Where flammable gas, dirt, and volatile matter (thinner, gasoline) exist, These matter might cause fire accident.



Earthing

- Refer to paper pattern when installing unit.

Cautions for the installation personnel

- Don't fail to show customers how to operate unit.

Installation Procedure

1 BEFORE INSTALLATION

<Don't discard any accessories until completed>

- Determine the way to carry unit to installation place.
- Don't remove packing until unit reaches installation place.
- If unpacking is unavoidable, protect unit properly.

2 SELECTION OF INSTALLATION PLACE

(1) Installation place shall meet the following and agreed by customers:

- Place where proper air flow can be ensured.
- No block to air flow.
- Water drainage is smooth.
- Place strong enough to support unit .
- Place where inclination is not evident on ceiling.
- Enough space for maintenance.
- Indoor and outdoor unit piping length is within limit. (Refer to Installation Manual for outdoor unit.)
- Indoor and outdoor unit, power cable, inter unit cable are at least 1 m away from T.V. radio. This is helpful to avoid picture disturbance and noise. (Even if 1 m is kept, noise can still appear if radio wave is strong)

(2) Ceiling height

Indoor unit can be installed on ceiling of 2.5-3m in height. (Refer to Field setting and Installation Manual of ornament panel.)

(3) Install suspending bolt. Check if the installation place is strong enough to hold weight. Take necessary measures in case it is not safe. (Distance between holes are marked on paper pattern. Refer to paper pattern for place which need be reinforced)

Installation space

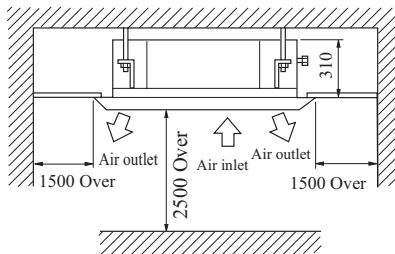

AB424FCAHA AB484FCAHA

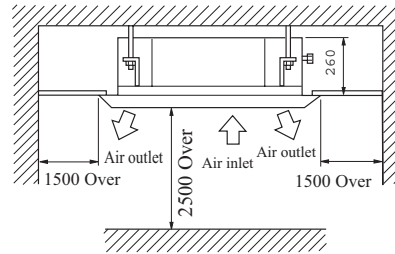

AB184FCAHA AB244FCAHA

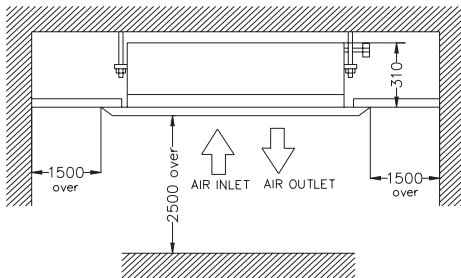

AB094FAAHA AB124FAAHA

Installation Procedure

3 PREPARATION FOR THE INSTALLATION

(1) Position of ceiling opening between unit and suspending bolt.

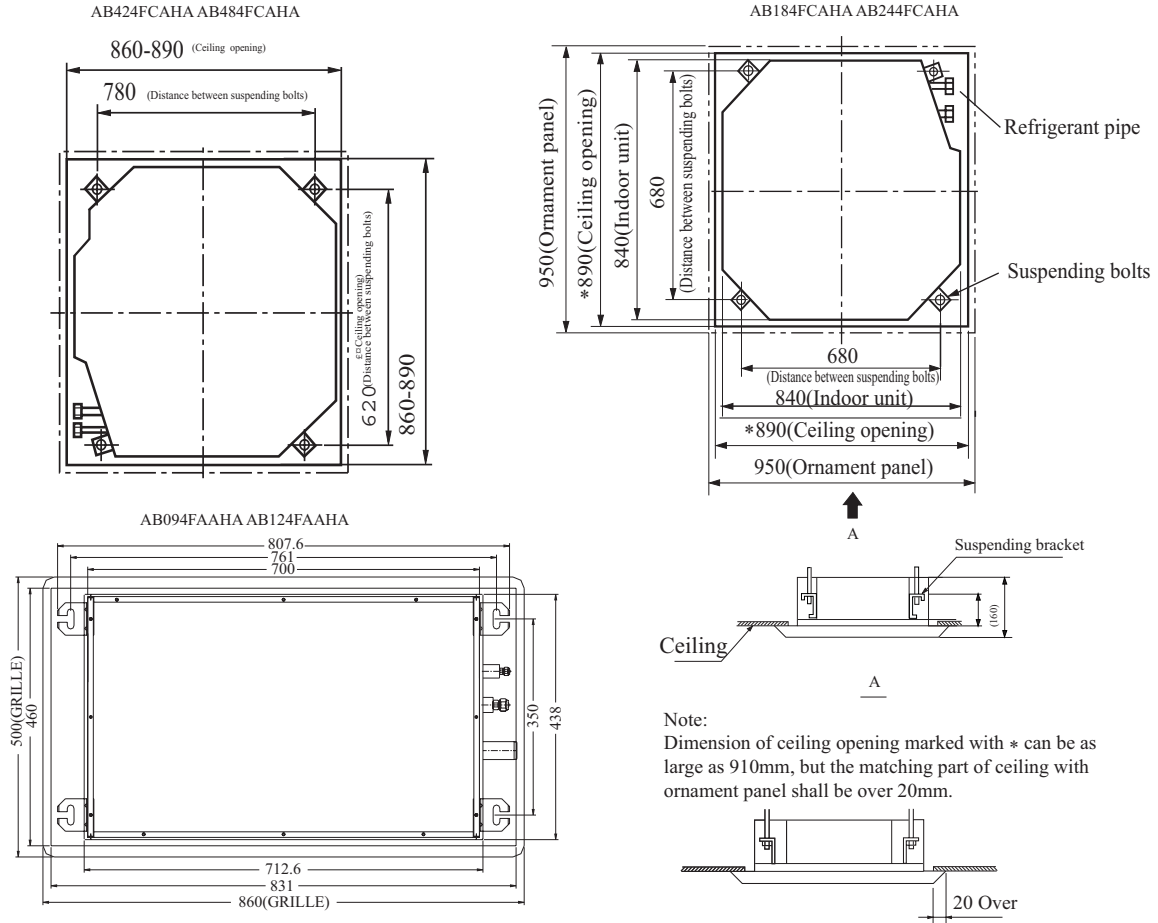

(2) Cut an opening in ceiling for installation if necessary. (when ceiling already exists.)

- Refer to paper pattern for dimension of ceiling hole.
- Connect all pipings (refrigerant, water drainage), wirings (inter unit cable) to indoor unit, before installation.
- Cut a hole in ceiling, may be a frame should be used to ensure a smooth surface and to prevent vibration. Contact your real estate dealer

(3) Install a suspending bolt.

(Use a M10 bolt)

To support the unit weight, anchor bolt shall be used in the case of already exists ceiling. For new ceiling, use built-in type bolt or parts prepared in the field. Before going on installing adjust space between ceiling.

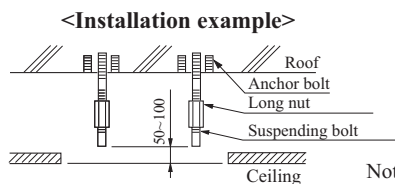

Note: All the above mentioned parts shall be prepared in field.

Installation Procedure

4 INSTALLATION OF INDOOR UNIT

In the case of new ceiling

- (1) Install unit temporarily
 - Put suspending bracket on the suspending bolt. Be sure to use nut and washer at both ends of the bracket.
- (2) ● As for the dimensions of ceiling hole, see paper pattern. Ask your real estate dealer for details.
 - Center of the hole is marked on the paper pattern.
 - Center of the unit is marked on the card in the unit and on the paper pattern.
 - Mount paper pattern ⑤ onto unit using 3 screws ⑥. Fix the corner of the drain pan at piping outlet.

< After installation on the ceiling >

- (3) Adjust unit to its right position. (Refer to preparation for the installation-(1))
- (4) Check unit's horizontal level.
 - Water pump and flating switch is installed inside indoor unit, check four corners of the unit for its level using horizontal compartor or PVC tube with water. (If unit is tilting against the direction of water drainage, problem may occur on floating switch, causing water leakage.)
- (5) Remove the washer mounting ②, and tighten the nut above.
- (6) Remove the paper pattern.

In the case of ceiling already exists

- (1) Install unit temporarily
 - Put suspending bracket on the suspending bolt. Be sure to use nut and washer at both ends of the bracket. Fix the bracket firmly.
- (2) Adjust the height and position of the unit. (Refer to preparation for the installation (1)).
- (3) Proceed with ③ and ④ of "In the case of new ceiling".

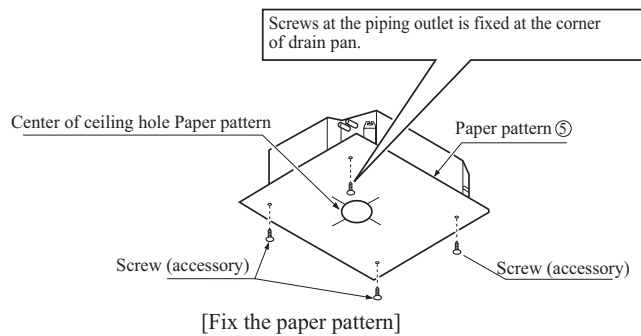
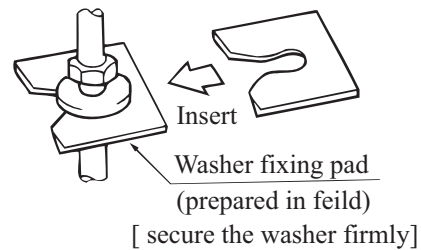
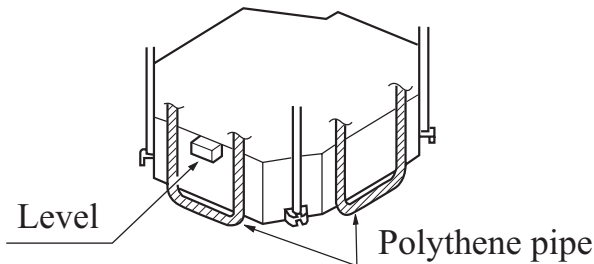
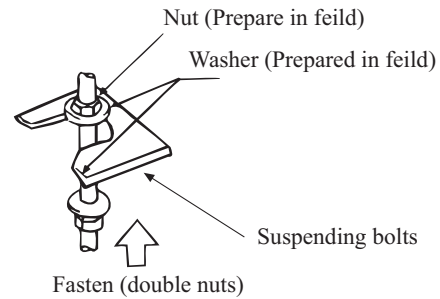

Installation Procedure

5 REFRIGERANT PIPING (As for outdoor piping, please refer to installation Manual of outdoor unit.)

- Outdoor is precharged with refrigerant.
- Be sure to see the Fig.1, when connecting and removing piping from unit.
- For the size of the flare nut, please refer to Table 1.
- Apply refrigerant oil at both inside and outside of flare nut. Tighten it band tight 3-4 turns then tighten it.
- Use torque specified in Table 1. (Too much force may damage flare nut, causing gas leakage).
- Check piping joints for gas leakage. Insulate piping as shown in Fig. below.
- Cover joint of gas piping and insulator ⑦ with seal.

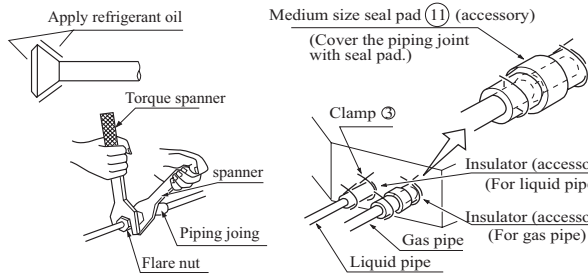

Table 1

Pipe size	Tighten torque	A(mm)	Flare shape
φ6.35	1420~1720N·cm (144~176kgf·cm)	8.3~8.7	
φ9.52	3270~3990N·cm (333~407kgf·cm)	12.0~12.4	
φ15.88	6180~7540N·cm (630~770kgf·cm)	18.6~19.0	
φ19.05	9720~11860N·cm (990~1210kgf·cm)	22.9~23.3	

6 INSTALLATION OF WATER DRAINAGE PIPE

(1) Install water drainage pipe

- Pipe dia. shall be equal or larger than that of unit piping. (pipe of polyethene; size: 25mm; O.D:32mm)
- Drain pipe should be short, with a downward slope at least 1/100 to prevent air bag from happening.
- If downward slope can't be made, take other measures to lift it up.
- Keep a distance of 1-1.5m between suspending brackets, to make water hose straight.

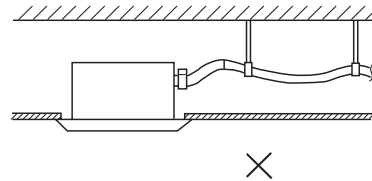
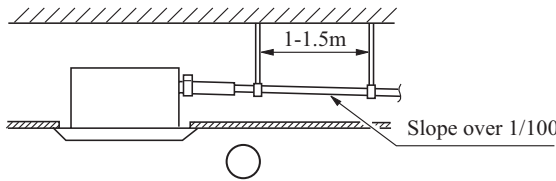

- Use the self-provided stiff pipe and clamp ① with unit. Insert water pipe into water plug until it reaches the white tape. Tighten the clip until head of the screw is less than 4mm from hose.
- Wind the drain hose to the clip using seal pad ⑨. Insulate drain hose in the room.

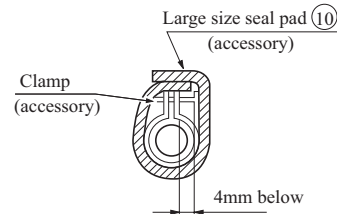
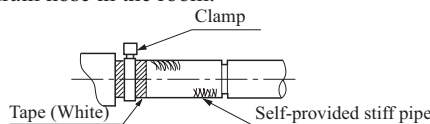

<Cautions for the drain water lifting pipe>

- Installation height shall be less than 280mm.
- There should be a right angle with unit, 300mm from unit.

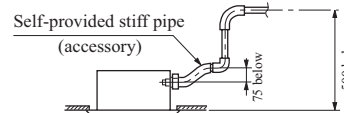
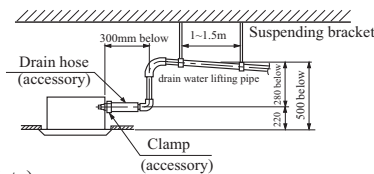

(Note)

- The slope of water drain hose (1) shall be within 75mm, don't apply too much force on it.
- If several water hoses join together, do as per following procedures.



Specifications of the water hoses shall meet the requirements for the unit running.

Installation Procedures

7 INSTALLING THE DECORATED BOARD ON THE BODY OF INDOOR UNIT

- As shown in Fig. 1, make the wind deflector motor of the decorated board face to the orifice of the indoor unit, and then mount the decorated board onto the body of the indoor unit.

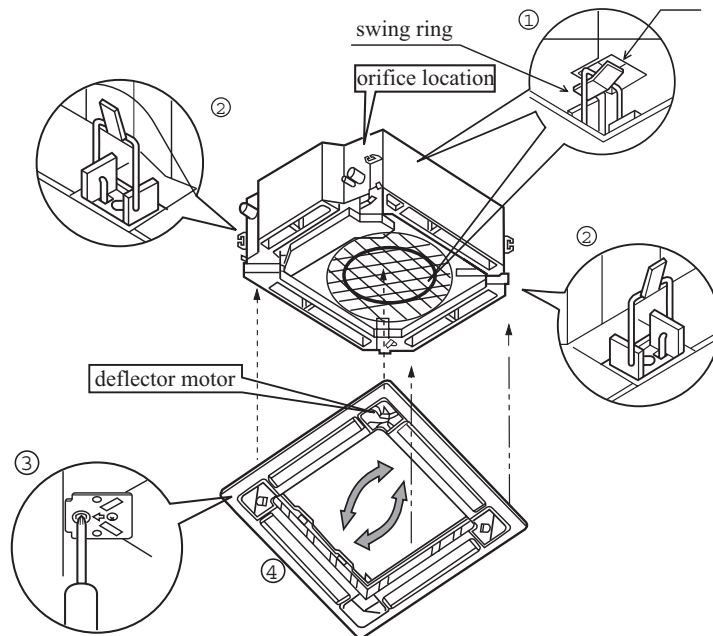

Fig.1

- Mounting the decorated board:

- a. Hang temporarily the swing rings(2 pcs) opposite to the deflector motor of the decorated board on the ring stators of the swing rings of the indoor unit;
- b. Hang temporarily the other swing rings on the ring stators of the swing rings of the indoor unit (take care not to get the lead wire of the deflector motor into the sealing);
- c. Screw all 4 hex head screws under the rings about 15mm to lift the board;
- d. Turn and adjust the decorated board in the direction of arrow as shown in Fig. 4 until it covers the hole of the ceiling.
- e. Fasten the screw to keep the thickness of the sealing between the decorated board and the unit body within 5-8mm, as shown in Fig. 2.

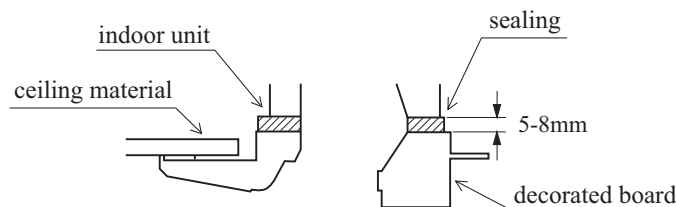

Fig.2

- f. Mount the wiring of the decorated board according to the mounting drawing attached to the inside of the machine;
- g. Check with the control if the mounting is correct and make sure if the machine work normally;
- h. Mount the air inlet grid and angle covers.

Installation Procedures

Attention

Inappropriate tightening of screws might cause the faults as shown in Fig. 3.

Tighten the screws properly.

If there is still a gap between the decorated board and the ceiling after tightening the screws, please readjust the height of the body of the indoor unit. (Fig. 4)

If the indoor unit keeps the horizontal level and the drainpipe can't be influenced, adjust the height of the body of the indoor unit from the holes on the angles of the decorated board.

Fig.3

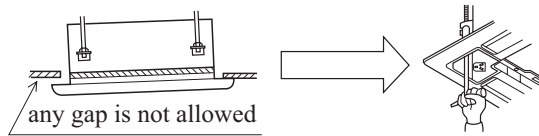
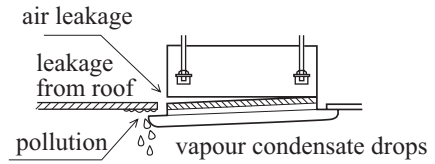

Fig.4

○ Wiring of Decorated Board

- a. Connect it to the connector of the wind deflector motor lead on the decorated board (Fig. 5);
- b. Connect it to the receiving terminal of remote control on the decorated board.

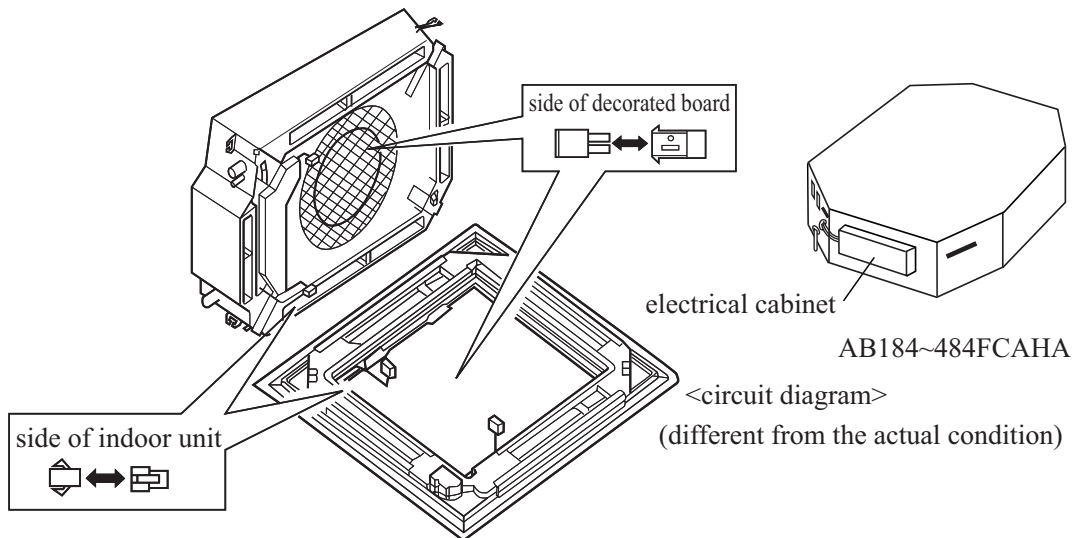

Fig.5

Installation Procedures

Mounting Air Inlet Grid and Angle Covers

(1) Mounting the air inlet grid:

Take care not to wind the lead of the wind deflector motor during mounting the air inlet grid.

(2) For Model AB184-484FCAHA units, the angle covers should be mounted on the angles.

- ϕ Tie the thread of the angle cover onto the cleat on the decorated board as shown in Fig. 6.
- ϕ Mount the angle cover onto the decorated board (as shown in Fig. 7).

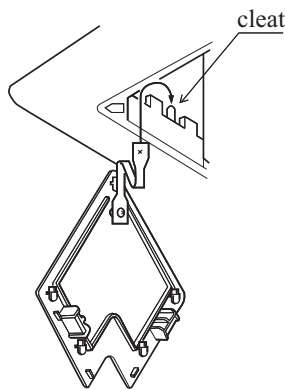

Fig.6

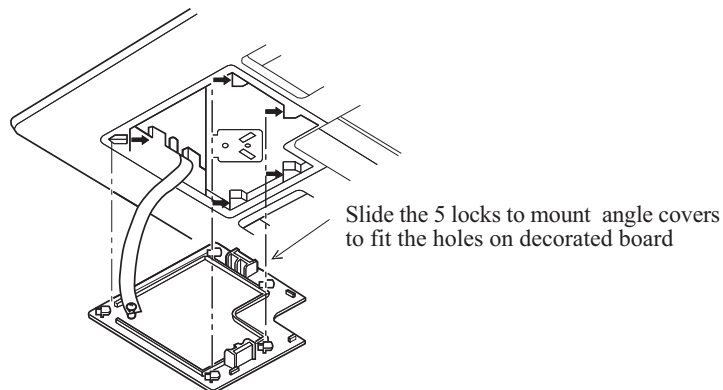

Fig.7

⚠ Attention

- For proper drainage, the drainpipes should be connected according to the installation manual. Heat preservation should be performed as to prevent condensing. Improper connections may cause the water leakage.

Requirements:

- The drainpipe of the indoor unit should be heat-insulated.
- Heat insulation should be treated for the connection with the indoor unit. Improper heat insulation may cause condensing.
- The drainpipe with the down gradient of over 1/100 can't be in the S shape, or abnormal sound can be caused.
- The lateral length of the drainpipe should be kept with 20m. Under the condition of long pipes, supports can be provided every 1.52m as to avoid unevenness.
- The central piping should be connected according the following drawing.
Take care not to apply external force on the connection of the drainpipes.
-
-

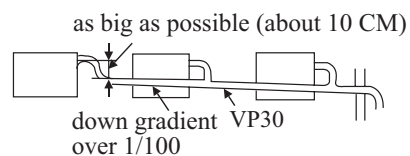
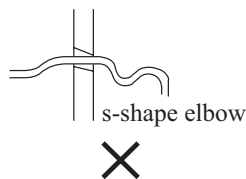
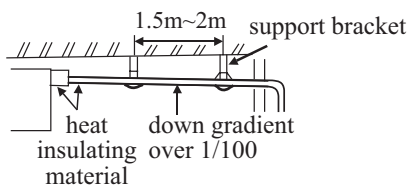

Installation Procedures

Piping Materials & Heat Insulating Materials

As to prevent condensation, heat insulating treatment should be performed. The heat insulating treatment for piping should be done respectively.

Piping Material	Hard PVC tube VP31.5mm (inner bore)
Heat Insulating Material	Vesicant polythene thickness: over 7mm

Hose

The attached hoses can be used to adjust the eccentricity and angle of the hard PVC tube.

- Stretch the hose directly to make connections as to avoid distortion. The soft end of the hose should be positioned with a clamp.
- The hose should be used in the lateral direction.

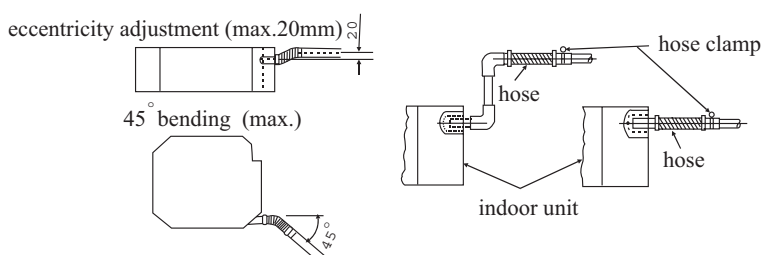

Heat Insulating Treatment:

- Wrap the connection between the clamp and the root segment of the indoor unit without any gap with heat insulating materials as shown in the drawing

Lifting Drainpipe

The drainpipe can be lifted 360mm.

When the down gradient of the drainpipe can't be ensured, after upright lifting, the drainpipe is in the down slope.

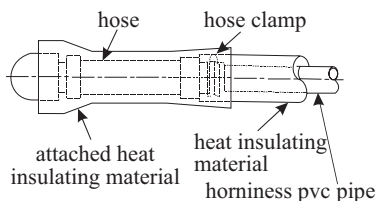

Confirming Drainage

The drainage should be confirmed during the test run to make sure that there is leakage at the connection.

The confirmation of drainage should be also performed during the installation in the winter season.

Fill water from the outlet or the specified position and confirm the drainage.

Fill 600cc water with a hose from the outlet or the specified location on the machine. Add the water slowly. Don't add water to the motor of the drainage pump.

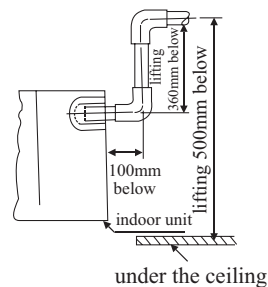

- After mounting the electrical system, do refrigerating operation and meanwhile add water and check.

If the electrical installation hasn't been completed, pull out the terminal(2P) of the floater switch on the electrical cabinet. After confirming the drainage,

- connect the terminal of the floater switch and run the drainage pump for 5 minutes until it stops automatically.

Confirm the sound of the motor:

- Confirm the sound of the motor of the drainage pump and meanwhile check the drainage.

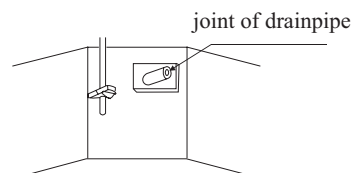

Installation Procedure

Tubing Permissible Length & Height Difference

Please refer to the attached manual of outdoor units.

Tubing Materials & Specifications

Model		AB094~ 124FAAHA	AB184~ 244FAAHA	AB424~ 484FAAHA
Tubing Size (mm)	Gas pipe	∅12.70	∅15.88	∅19.05
	Liquid pipe	∅6.35	∅9.52	∅9.52
Tubing Material	Phosphor deoxybronze seamless pipe (TP ₂) for air conditioner			

Refrigerant Filling Amount

Add the refrigerant according to the installation instruction of outdoor unit. The addition of R22 refrigerant must be performed with a measure gage to ensure the specified amount while compressor failure can be caused by filling too much or little refrigerant.

Connecting Procedures of Refrigerant Tubing

Proceed the flare tube connecting operation to connect all the refrigerant tubes.

- Dual wrenches must be used in the connection of indoor unit tubing.
- Mounting torque refers to the right table

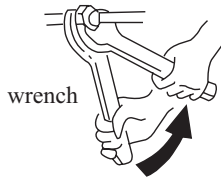

Outer Diameter of Tubing (mm)	Mounting Torque (N-m)	Increase mounting Torque (N-m)
∅ 6.35	11.8 (1.2kgf-m)	13.7 (1.4kgf-m)
∅ 9.52	24.5 (2.5kgf-m)	29.4 (3.0kgf-m)
∅ 12.70	49.0 (5.0kgf-m)	53.9 (5.5kgf-m)
∅ 15.88	78.4 (8.0kgf-m)	98.0 (10.0kgf-m)
∅ 19.05	98.0 (10.0kgf-m)	117.7 (12.0kgf-m)

Cutting and Enlarging

Cutting or enlarging pipes should be proceeded by installation personnel according to the operating criterion if the tube is too long or flare opening is broken.

Vacuumizing

Vacuumize from the stop valve of outdoor units with vacuum pump. Refrigerant sealed in indoor machine is not allowed to use for vacuumization.

Open All Valves

Open all the valves of outdoor units. [NB: oil balancing stop valve must be shut up completely when connected one main unit.]

Checkup for Air Leakage

Check if there is any leakage at the connecting part and bonnet with hydrophone or soapsuds.

Connecting

Connecting circular terminals:



1. Connecting circular terminals:
The connecting method of circular terminal is shown in the Fig. Take off the screw, connect it to the terminal tier after heading it through the ring at the end of the lead and then tighten it.
2. Connecting straight terminals:
The connection methods for the circular terminals are shown as follows: loosen the screw before putting the line terminal into the terminal tier, tighten the screw and confirm it has been clamped by pulling the line gently.
3. Pressing connecting line
After connecting line is completed, press the connecting line with clips which should press on the protective sleeve of the connecting line.

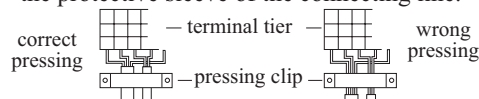

Electrical Wiring

⚠ Warning

- Electrical construction should be made with specific mains circuit by the qualified personnel according to the installation instruction. Electric shock and fire may be caused if the capacity of power supply is not sufficient. ⚠
- During arranging the wiring layout, specified cables should be used as the mains line, which accords with the local regulations on wiring. Connecting and fastening should be performed reliably to avoid the external force of cables from transmitting to the terminals. Improper connection or fastness may lead to burning or fire accidents. ⚠
- There must be the ground connection according to the criterion. Unreliable grounding may cause electrical shocks. Do not connect the grounding line to the gas pipe, water pipe, lightning rod and telephone line. ⚠

⚠ Attention

- Only copper wire can be used. Breaker for electric leakage should be provided, or electric shock may occur.
- The wiring of the mains line is of Y type. The power plug L should be connected to the live wire and plug N connected to null wire while ⊕ should be connected to the ground wire. For the type with auxiliary electrically heating function, the live wire and the null wire should not be misconnected, or the surface of electrical heating body will be electrified. If the power line is damaged, replace it by the professional personnel of the manufacturer or service center.
- The power line of indoor units should be arranged according to the installation instruction of indoor units.
- The electrical wiring should be out of contact with the high-temperature sections of tubing as to avoid melting the insulating layer of cables, which may cause accidents.
- After connected to the terminal tier, the tubing should be curved into be a U-type elbow and fastened with the pressing clip.
- Controller wiring and refrigerant tubing can be arranged and fixed together. ⚠
- The machine can't be powered on before electrical operation. Maintenance should be done while the power is shut down.
- Seal the thread hole with heat insulating materials to avoid condensation.
- Signal line and power line are separately independent, which can't share one line. [Note: the power line, connecting line, signal line are provided by users. Parameters are shown as below: 3 (1.0-1.5) mm²; parameters for signal line: 2 (0.75-1.25)mm²(shielded line)]

Supply Wiring Drawing

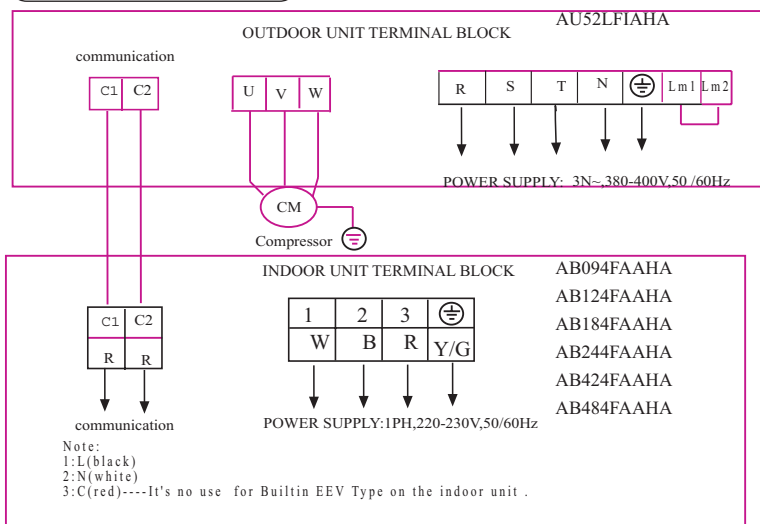

Electrical Wiring

Field setting

Field setting the unit number

In order to realize central control of the MRV air conditioning system, its necessary to set the indoor unit number (control address).

Indoor unit number setting

Indoor unit number setting switch and confirmation of the settings.

There is a 4-position dial switch for setting the indoor unit number and fan speed level on the computer board of the indoor unit.

Setting way is as follows:

Before connecting the power supply, please set the indoor unit number manually according to the following table

Matrix of the dial switch and indoor unit number

Position 1	Position 2	Position 3	Representing unit number
0	0	0	1
1	0	0	2
0	1	0	3
1	1	0	4
0	0	1	5
1	0	1	6
0	1	1	7
1	1	1	8

- The first bit of SW02 and SW03 is used to choose wired control or remote control type .
 ON means that the unit with wired controller .And OFF is remote controller.
- The second bit of SW02 is used to choose built-in or outside electronic expansion valve setting.
 ON means built-in type.And "OFF" means outside type.
- The second bit of SW03 is used to select the twin energy source function.
 "ON":The unit without TES function.
 "OFF":The unit can be used as TES function.
 When it is used for TES function ,the water temperature sensor is available .

SW02

Example:

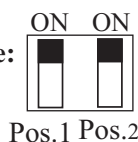

SW03

Example:

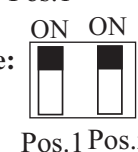

SW01

Example:

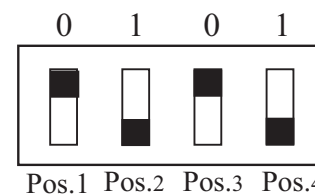
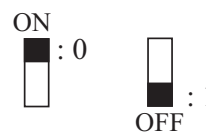

Setting for No. 3 indoor unit

"ON" means that in heating mode the indoor unit fan speed can be choosed to middle and low level. "OFF" means that the indoor unit fan speed can be choosed to high, middle and low level.After producing in plant , the position is "OFF".

Auto restart (to be applied for a necessary situation) :

After the **Auto restart** is set, if power failure suddenly occurs while the air conditioner is working, it will resume the previous working state when the power is supplied again.

*The setting method of auto restart function of wired remote control model or wired control+ remote control model:press the [sleep] button of the wired control or remote control 10 times within 5 seconds and after the buzzer rings 4 times,the air conditioner will enter the state of auto restart function.

The cancel method :press the [sleep] button of the wired control or remote control 10 times within 5 seconds and after the buzzer rings 2 times, the Auto restart function will be cancelled.The setting method of wireless remote control:press the [swing] button of the remote control 10 times within 5 seconds and after the buzzer rings 4 times,the air conditioner will enter the state of auto restart function;

The cancel method :press the [swing] button of wireless remote controller 10 times within 5 seconds and after the buzzer rings 2 times, the Auto restart function will be cancelled;

*The setting method of wireless remote control:press the [swing] button of the remote control 10 times within 5 seconds and after the buzzer rings 4 times,the air conditioner will enter the state of auto restart function;

The cancel method :press the [swing] button of wireless remote controller 10 times within 5 seconds and after the buzzer rings 2 times, the Auto restart function will be cancelled;

Notes: When a power failure suddenly occurs during the air conditioner is working after the **Auto restart** is set, if the air conditioner will not be used for a long time, please cut off the power supply to prevent its operation from being resumed after the power is supplied again, or press the "Switch On/Off" button after the power comes again.

Electrical Wiring

The unit has temperature compensation function.

(Only used for remote controller)

You can use [swing] button of the remote controller to set or cancel temperature compensation function.

(1) About temperature compensation function setting

* The setting method for heating mode:

press [ON/OFF] button of the remote controller to start the indoor unit, setting temperature: 24℃, press [swing] button 7 times in 5 seconds, the buzzer will ring twice, and enter heating temp. compensation mode.

set compensation temp. , if the set temp. is 25℃, the compensation temp. is +1℃, you can set it in range of 0℃ to +6℃

*The setting method for cooling mode:

press [ON/OFF] button of the remote controller to start the indoor unit, setting temperature: 24℃ : press [swing] button 7 times in 5 seconds, the buzzer will ring twice, and enter cooling temp. compensation mode.

(2) Temperature compensation function checking

*In cooling mode, setting temp.: 30 degree, High fan speed, press [swing] button 7 times in 5 seconds, The Running lamp will flash, the times of flash is same with cooling compensation setting number

*In heating mode, setting temp. :16 degree, high fan speed, press [swing] 7 times in 5 seconds, the running lamp will flash, the flashing times is same with heating compensation setting number

Concerning MRV Auto Restart function for H-MRV models

Haier Auto Restart function when the unit power drops down suddenly, the unit microprocessor will store the previous working condition and when the power is on again, the unit will run as this memory.

Auto Restart function is designed basically on the MRV whole system, but it is suitable for each indoor unit individually.

If some of indoor units power cut down, but the outdoor unit and the other indoor units still work, maybe problems will happen such as freezing at cooling mode and overload protection at heating mode on those indoor units without power.

Reason

When one or some indoor units power drops down and the other indoor units are still work, the indoor units without the power, will keep the previous working condition before the power is off.

And expansion valve keeps open at a kind of opening rate condition as the previous requirement, so there is refrigerant flowing in the exchanger, but the indoor fan stops working. If the units work at cooling mode, the indoor units without the power will maybe make freezing. If the unit works at heating mode, maybe the outdoor unit compressor will stop because of the pressure or temperature protection. This is our design basically on Auto Restart function currently.

Haier, Herewith, solemnly informs our customers, installers, distributors, etc. **when making installation, please make sure when the power is shut down whether artificially or accidentally, the whole system including outdoor unit and all the indoor units must be off. If you do not make the installation as our indication, Haier will not be responsible for any problem resulting from this.**

Pay special care to the following and check after installation

Item to be checked	Unproper installation may cause	Check
	Unit might fall down, make vibration or noise.	
Is gas leakage check performed?	This may lead to gas shortage.	
Is unit properly insulated?	Dew or water drop may occur.	
Is water drainage smooth?	Dew or water drop may occur.	
Is power voltage meet that stipulated on the nameplate?	Problem may occur or parts got burned.	
Is wiring and piping correctly arranged?	Problem may occur or parts got burned.	
Is unit safely grounded?	There might be a danger of electric shock.	
Is wire size correct?	Problem may occur or parts got burned.	
Are there any obstacles on air inlet and outlet grill of indoor and outdoor unit?	This may cause poor cooling.	
Is record made for piping length and refrigerant charging amount?	It is hard to control refrigerant charging amount.	

Technical Specifications

Model	AB094FAAHA	AB124FAAHA	A184FCAHA	AB244FCAHA
Power Supply	1PH.220V~,60Hz	1PH.220V~,60Hz	1PH.220V~,60Hz	1PH.220V~,60Hz
Cooling Capacity	2800W	3600W	6000W	7200W
heating Capacity	3200W	3900W	6300W	8000W
Noise (Indoor Units)	--	--	34dB(A)	35 dB(A)
Net Weight (Indoor Units)	20kg	20kg	28kg	28kg
Air Volume (Indoor Units)	400m ³ /h	450m ³ /h	900m ³ /h	1020m ³ /h
Net Dimensions (mm)	710*440*270	710*440*270	840*840*240	840*840*240
Panel Dimensions (mm)	860*500*60	860*500*60	950*950*80	950*950*80
Refrigerant liquid pipe/ Refrigerant gas pipe	6.35/12.7	6.35/12.7	9.52/15.88	9.52/15.88

Model	AB424FCAHA	AB484FCAHA		
Power Supply	1PH.220V~,60Hz	1PH.220V~,60Hz		
Cooling Capacity	2800W	3600W		
heating Capacity	3200W	3900W		
Noise (Indoor Units)	37dB(A)	42dB(A)		
Net Weight (Indoor Units)	35kg	35kg		
Air Volume (Indoor Units)	1580m ³ /h	1920m ³ /h		
Net Dimensions (mm)	840*840*295	840*840*295		
Panel Dimensions (mm)	950*950*80	950*950*80		
Refrigerant liquid pipe/ Refrigerant gas pipe	9.52/19.05	9.52/19.05		