

POWER SERIES®

Px300.4

Px600.2

BPx500.1

BPx1100.1

BPx2200.1

car audio
power amplifier
owner's manual



THE OFFICIAL BRAND
OF LIVE MUSIC.



THANK YOU

for purchasing a JBL Power Series® amplifier.
In order that we may better serve you should you
require warranty service for your new amplifier, please
retain your original purchase receipt and return the
enclosed warranty registration card.



Designed and Engineered
in the USA

INSTALLATION

WARNING: Playing loud music in an automobile can hinder your ability to hear traffic and permanently damage your hearing. We recommend listening at low or moderate levels while driving your car. JBL accepts no liability for hearing loss, bodily injury or property damage resulting from the use or misuse of this product.

IMPORTANT: To get the best performance from your JBL Power Series® amplifiers, we strongly recommend that installation be entrusted to a qualified professional. Although these instructions explain how to install JBL Power Series amplifiers in a general sense, they do not show specific installation methods that may be required for your particular vehicle. If you do not have the necessary tools or experience, do not attempt the installation yourself. Instead, please ask your authorized JBL car audio dealer about professional installation.

INSTALLATION WARNINGS AND TIPS

- Always wear protective eyewear when using tools.
- Turn off all audio systems and other electrical devices before you start. Disconnect the (–) negative lead from your vehicle’s battery.
- Check clearances on both sides of a planned mounting surface before drilling any holes or installing any screws. Remember that the screws can extend behind the surface.

- At the installation sites, locate and make a note of all fuel lines, hydraulic brake lines, vacuum lines, and electrical wiring. Use extreme caution when cutting or drilling in and around these areas.
- Before drilling or cutting holes, use a utility knife to remove unwanted fabric or vinyl to keep material from snagging in a drill bit.
- When routing cables, keep input-signal cables away from power cables and speaker wires.
- When making connections, make certain they are secure and properly insulated.
- If the amplifier’s fuse must be replaced, use only the same type and rating as that of the original. Do not substitute another kind.

CHOOSING A LOCATION AND MOUNTING THE AMPLIFIER

Amplifiers need air to stay cool. Suitable locations are under a seat (provided the amplifier doesn’t interfere with the seat adjustment mechanism), in the trunk, or in any other location which provides enough air for the amp to cool itself. Do not mount the amplifier with the heat sink facing downward, as this makes convection cooling of the amplifier impossible.

Mount the amplifier so that it is not damaged by the feet of backseat passengers or shifting cargo in the trunk. Mount the amplifier so that it remains dry – never mount an amplifier outside the car or in the engine compartment. Using the amplifier as a template, mark the location of the mounting holes on the mounting surface, drill pilot holes, and attach the amplifier to the mounting surface with screws. Make sure the amplifier is mounted securely.

POWER CONNECTIONS

The Power Series amplifiers are capable of delivering extremely high power levels, and require a heavy-duty and reliable connection to the vehicle’s electrical system in order to perform optimally. Please adhere to the following instructions carefully:

Ground Connection

Connect the amplifier’s Ground (GND) terminal to a solid point on the vehicle’s metal chassis, as close to the amplifier as possible. Refer to the chart below to determine minimum wire-gauge size. Scrape away any paint from this location; use a star-type lock washer to secure the connection.

Power Connection

Connect a wire (see chart at right for appropriate gauge) directly to the vehicle’s positive battery terminal, and install an appropriate fuse holder within 18" of the battery terminal. *Do not install the fuse at this time.* Route the wire to the amplifier’s location, and connect it to the amplifier’s Positive (BATT +) terminal. Be sure to use appropriate grommets whenever routing wires through the firewall or other sheet metal. *Failure to adequately protect the positive wire from potential damage may result in a vehicle fire.* When you are done routing and connecting this wire, you may install the fuse at the battery.

NOTE: The BPx2200.1 is supplied with an external 150A fuse. If you are running a dedicated wire to this amplifier, this fuse should be installed near the battery, as specified above. If you are running multiple amplifiers off a power distribution block, this fuse should be installed between the distribution block and the BPx2200.1.

In any case, a fuse must be installed within 18" of the battery terminal.

Remote Connection

Connect the amplifier’s Remote (REM) terminal to the source unit’s Remote Turn-On lead using a minimum of 18-gauge wire.

Speaker Connections

Refer to the application guides on the pages that follow. Speaker connections should be made using a minimum of 1.5 mm² wire.

Wire Gauge Chart

Amplifier Model	Maximum Current Draw	Minimum Wire
Px300.4	78A	16 mm ²
Px600.2	78A	16 mm ²
BPx500.1	50A	10 mm ²
BPx1100.1	110A	25 mm ²
BPx2200.1	190A	2 x 25 mm ²

These recommendations assume 2,3 to 3,5 m wire runs. If your installation differs markedly, you will need to adjust the wire gauge accordingly.

Important Note: If you are planning to use optional neon tubes, you *must* install them before making any electrical connections to the amplifier (refer to “Installing Neon Tubes” on page 7).

APPLICATIONS - BPX MODELS

To the right are several application diagrams to help plan your subwoofer system installation. **Figures 1 through 3** show how to configure the JBL Power Series subwoofer amplifiers (models BPx500.1, BPx1100.1 and BPx2200.1) for 2-channel, bridged-mono and parallel-mono operation (also see "Setting the Output Mode" on page 6).

NOTE: For simplicity, Figures 1 through 3 do not show power, remote and input connections.

If the nominal impedance of your speaker system is close to 2 ohms, be prepared to try both bridged and parallel configurations to determine which performs better.

Set OUTPUT MODE to 2CH/BR (on input panel)



See "Setting the Crossover(s)" on page 6 to adjust X-OVER controls (on input panel)

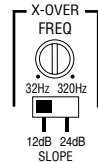
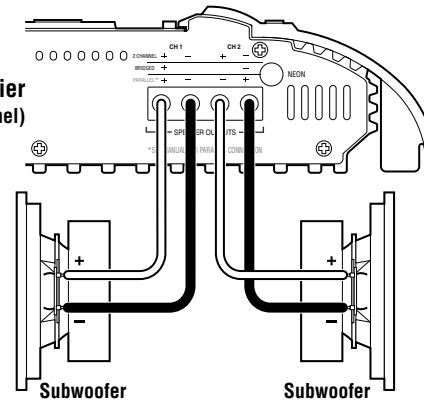

Figure 1. The JBL Power Series subwoofer amplifier is set to 2-channel mode to drive a pair of subwoofers.



Set OUTPUT MODE to 2CH/BR (on input panel)



See "Setting the Crossover(s)" on page 6 to adjust X-OVER controls (on input panel)



Figure 2. The JBL Power Series subwoofer amplifier is set to bridged (mono) mode to drive a single subwoofer. Use this mode only when the nominal impedance of the speaker system is 2 ohms or greater.

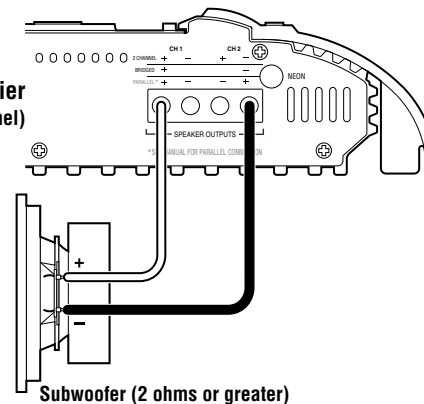

Set OUTPUT MODE to PARALLEL (on input panel)



See "Setting the Crossover(s)" on page 6 to adjust X-OVER controls (on input panel)



Figure 3. The JBL Power Series subwoofer amplifier is set to parallel mode to drive a single subwoofer. Use this mode only when the nominal impedance of the speaker system is less than 2 ohms.

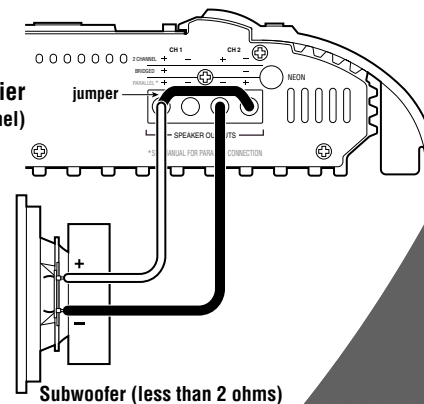

NOTE: A jumper is added between the + terminals.

APPLICATIONS - PX600.2

The JBL Px600.2 amplifier can be set up for stereo or bridged-mono operation, as shown in **Figures 4 and 5**.

NOTE: For simplicity, Figures 4 and 5 do not show power, remote and input connections.

Figure 4. The JBL Px600.2 amplifier is set to stereo mode to drive a pair of full-range speakers.

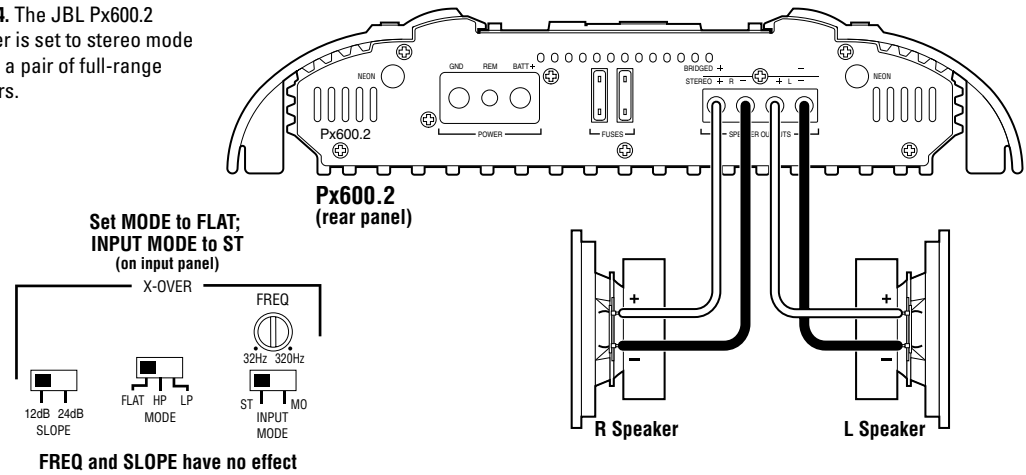
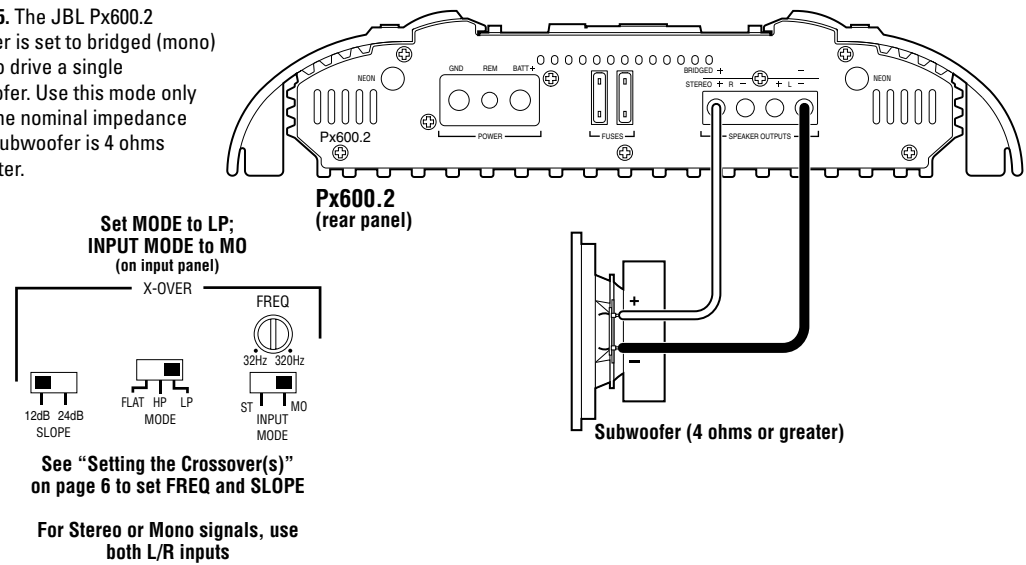

Figure 5. The JBL Px600.2 amplifier is set to bridged (mono) mode to drive a single subwoofer. Use this mode only when the nominal impedance of the subwoofer is 4 ohms or greater.



APPLICATIONS - Px300.4

The JBL Px300.4 amplifier can be set up for stereo or tri-mode operation, as shown in **Figures 6 and 7**.

NOTE: For simplicity, Figures 6 and 7 do not show power, remote and input connections.

Figure 6. The JBL Px300.4 amplifier is set to stereo mode to drive front and rear pairs of full-range speakers.

NOTE: To limit bass sent to full-range speakers, set X-OVER MODE to HP. See page 6 to set FREQ and SLOPE.

Set REAR and FRONT INPUT MODE to ST (on input panel)



Set REAR and FRONT X-OVER MODE to FLAT (on input panel)

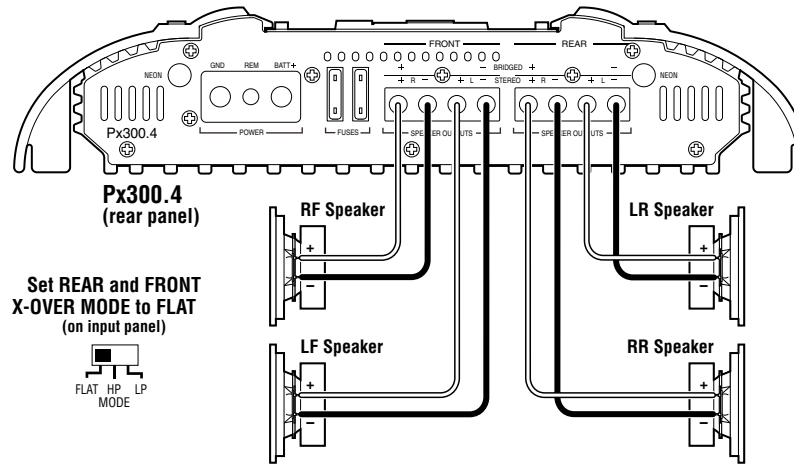

Figure 7. The JBL Px300.4 amplifier is set to drive a stereo component system and a subwoofer with a nominal impedance of 4 ohms or greater.

NOTE: To drive a pair of rear midbass speakers (instead of subwoofer), set INPUT MODE to ST, X-OVER MODE to LP, and use DBO to set HP filter.

Set FRONT INPUT MODE to ST (on input panel)



Set REAR INPUT MODE to MO (on input panel)



Set FRONT X-OVER MODE to HP (on input panel)



Set REAR X-OVER MODE to LP (on input panel)



See "Setting the Crossover(s)" on page 6 to set FREQ and SLOPE

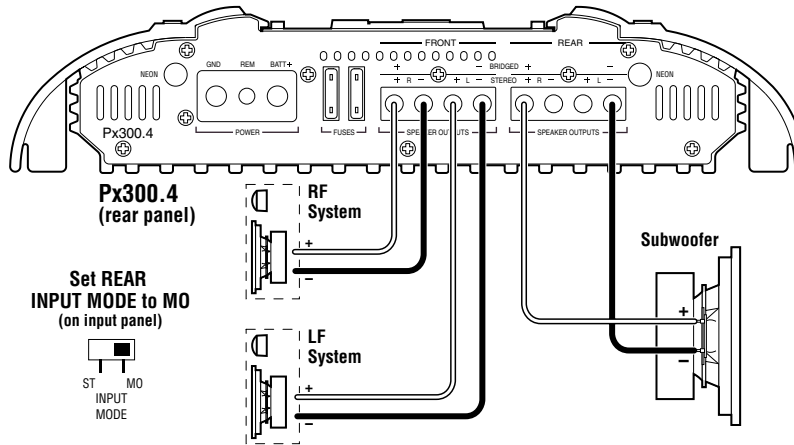

INSTALLATION AND SETUP

SETTING THE OUTPUT MODE

Setting an output mode depends on your choice of system configuration and the nominal impedance of your speaker system. JBL Power Series BPx amplifiers provide rated power into any impedance between 1 and 4 ohms. The BPx500.1, BPx1100.1 and BPx2200.1 amplifiers can be configured to provide high voltage to loads of 2 ohms or greater, or high current for loads below 2 ohms.

Using the Bridge Mode

If your speaker system has a nominal impedance of 2 ohms or greater, bridge the amplifier's two channels to drive the speaker(s). On BPx models, set the OUTPUT MODE switch to 2CH/BR (see **Figure 2** on page 3).

Using the Parallel Mode (BPx Models Only)

If the nominal speaker-system impedance is less than 2 ohms, connect the two amplifier channels in parallel to drive the speaker(s), as shown in **Figure 3** on page 3. On BPx models, set the OUTPUT MODE switch to PARALLEL.

NOTE: If the nominal impedance of your subwoofer system is close to 2 ohms, try both series and parallel to determine which mode provides the highest volume. Use the I/E OPT LED according to "Setting Input Sensitivity" on the right.

Using the 2-Channel Mode

With any Power Series amplifier, you can also drive two woofers separately by connecting the speakers in the 2-channel mode (see **Figure 1** on page 3). In this mode, the minimum nominal impedance is 2 ohms. On BPx models, set the OUTPUT MODE switch to 2CH/BR.

SETTING THE CROSSOVER(S)

IMPORTANT: If you plan to use the Px300.4 or Px600.2 to drive full-range speakers, set the X-OVER MODE switch(es) to FLAT and skip to the next section, "Setting Input Sensitivity."

1. Initially set the X-OVER FREQ control(s) midway. Later, when listening to music (in the next section), adjust them for least-perceived distortion from midrange and high-frequency speakers, while allowing them to reproduce as much bass as possible.
2. Depending on your system plan, set the X-OVER MODE switch(es) to LP (low-pass), HP (high-pass), or FLAT.
3. For HP filters, set the X-OVER SLOPE switch(es) to 24dB to limit bass and provide increased system volume with less distortion.

For LP filters, use 12dB or 24dB according to taste. However, using a 24dB slope will make bass less directional since midrange frequencies are being filtered from the woofer's response. When choosing a low-pass filter frequency for your subwoofers, choose the highest frequency that will remove vocal information from the sound of the subwoofer.

SETTING INPUT SENSITIVITY

NOTE: For BPx models, you can use the supplied REMOTE LEVEL CONTROL instead of the amplifier's INPUT LEVEL control to set input sensitivity. Connect the remote module's attached cable to the REMOTE LEVEL CONTROL (RJ-11) jack on the amplifier's input panel.

1. Initially, turn the INPUT LEVEL control(s) to the minimum (counterclockwise) position(s).
2. Reconnect the (-) negative lead to your vehicle's battery. Apply power to the audio system and play a dynamic music track from CD or tape.

NOTE: After the source unit is on, blue LEDs (on the top panel) will illuminate, indicating the amplifier is on. If not, check the wiring, especially the remote connection from the source unit. Also refer to "Troubleshooting" on the next page.

3. On the source unit, increase the volume control to maximum position. Slowly increase the INPUT LEVEL control(s) (clockwise) towards three o'clock and observe the I-E/OPT LED (on the amplifier top). At the ideal setting, it should flash on musical peaks, signifying maximum voltage is being delivered in the 2-channel or bridge modes, or maximum current is being delivered in the parallel mode. If the I-E/OPT LED is on steadily, the amplifier is being overdriven. Turn the INPUT LEVEL control(s) back slightly until the I-E/OPT LED flashes on musical peaks.

SETTING DBO (ALL MODELS EXCEPT PX600.2)

Dynamic Bass Optimizer™ (DBO) is a new approach to enhancing low-frequency reproduction in a vehicle. Conventional bass boost controls add bass at a fixed frequency and cause the amplifier to consume considerable power. DBO conserves valuable power at the lowest frequencies and allows you to adjust the level and "character" of the bass sound, instead of just the amount of boom.

Since a subwoofer in a vented box is given to overexcursion below the tuned frequency, set the HP FREQ control 10Hz below the box's resonant (tuned) frequency (e.g., 30Hz for a vented box tuned to 40Hz). Power typically wasted in this region will now be conserved and be available for frequencies the enclosure will reproduce. Use the BOOST Installation and setup control to boost the bass at the set frequency by as much as 12dB, as shown in **Figure 8**.

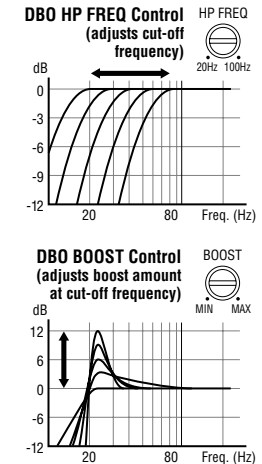

Figure 8. Frequency response curves show typical DBO control ranges for selected JBL Power Series amplifiers.

INSTALLATION AND SETUP

For sealed enclosures, use DB0 to enhance the middle of the bass region. Set the HP FREQ control to 35Hz to 40Hz and adjust the BOOST control to taste. This will make the bass sound bigger and fuller. Alternatively, for tighter-sounding bass, set the HP FREQ control between 45Hz and 50Hz, and also adjust the BOOST control according to your preference.

For infinite-baffle applications, set the HP FREQ control to the speaker's F_s value (to keep the subwoofer from trying to create bass below the resonant frequency) and adjust the BOOST control to taste.

INSTALLING NEON TUBES (OPTIONAL)

1. Using a Phillips screwdriver, remove all screws on the amplifier's output/power end panel and set them aside.
2. Using a 3/32-inch Allen wrench, remove only the screws on the amplifier's (top) clear cover and set them aside.
3. Remove the end panel and slide the cover off. Set both parts aside.

4. Locate the enclosed hardware bag and remove the four clips. Each clip has a square end and a larger round end. Using a round end, press two clips onto each neon tube (e.g., Street Glow AN9 or equivalent), as shown in **Figure 9** below.
5. For each tube, align both clips so the square ends slide onto an exposed extrusion edge, as shown in Figure 9. Do not cover any screw holes. When installed correctly, each neon tube will sit under an extrusion and not be visible when viewed from directly above.
6. Route each neon tube's power cable through its respective NEON hole on the end panel (see **Figure 9**).
7. Slide the cover back into place and reinstall its screws. Then, replace the end panel and reinstall its screws.
8. Finish the installation of the neon tubes as instructed in their owner's manual.

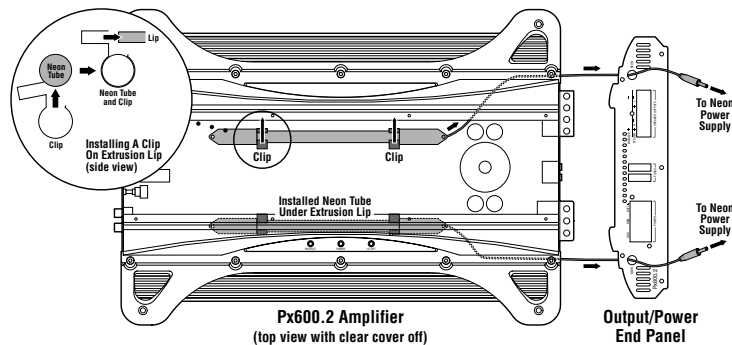

Figure 9.
Installing neon tubes in a JBL Px600.2 amplifier.
Installation is similar for other models.

TROUBLESHOOTING

SYMPTOM	LIKELY CAUSE	SOLUTION
No audio (POWER LED is off)	No voltage at BATT+ or REM terminals, or bad or no ground connection	Check voltages at amplifier terminals with VOM
No audio (PROTECT LED flashes every 4 sec.)	DC voltage on amplifier output	Amplifier may need service; see enclosed warranty card for service information
No audio (PROTECT LED is on)	Amplifier is overheated	Make sure amplifier cooling is not blocked at mounting location; verify speaker-system impedance is within specified limits (see "Specifications" on the next page)
No audio (PROTECT and POWER LEDs flash)	Voltage less than 9V on BATT+ connection	Check vehicle charging system for defective voltage regulator
I-E/OPT LED is on all times (not flashing)	Amplifier is being overdriven	Check INPUT LEVEL setting; see previous page
No audio (PROTECT LED is on)	Voltage more than 16V or less than 8.5V on BATT+ connection regulator	Check vehicle charging system for defective voltage regulator
Distorted audio	Input sensitivity is not set properly, or amplifier or source unit is defective	Check INPUT LEVEL setting; or check speaker wires for shorts or grounds
Distorted audio and PROTECT LED flashes	Short circuit in speaker or wire	Remove speaker leads one at a time to locate shorted speaker or wire, then repair
Music lacks "punch"	Speakers are not connected properly	Check speaker connections for proper polarity

SPECIFICATIONS

	Px300.4	Px600.2	BPx500.1	BPx1100.1	BPx2200.1
Power Output, 4 Ohms	75W x 4	150W x 2	N/A	N/A	N/A
Power Output, 2 Ohms	150W x 4	300W x 2	250W x 2	575W x 2	1100W x 2
Power Output, Bridged, 4 Ohms	300W x 2	600W x 1	500W x 1	1100W x 1	2200W x 1
Power Output, Parallel, 1 Ohm	N/A	N/A	500W x 1	1100W x 1	2200W x 1
Min. Speaker Impedance	2 ohms	2 ohms	1 ohm	1 ohm	1 ohm
Frequency Response	11Hz ~ 45kHz, +1dB	10Hz ~ 45kHz, +1dB	20Hz ~ 320Hz, -3dB	20Hz ~ 320Hz, -3dB	20Hz ~ 320Hz, -3dB
Input Sensitivity (RCA type)	250mV ~ 6V	250mV ~ 6V	250mV ~ 6V	250mV ~ 6V	250mV ~ 6V
THD + Noise (4 Ohms)	0.04%	0.04%	0.5%	0.5 %	0.5 %
Signal-to-Noise	95dB	95dB	93dB	93dB	93dB
Maximum Current Draw	78A	78A	50A	110A	190A
Fuse Replacement	30A x 2	30A x 2	30A x 2	30A x 3	150A x 1 external fuse
Dimensions (H x W x L)	312mm x 432mm x 66mm	312mm x 432mm x 66mm	312mm x 330mm x 66mm	312mm x 432mm x 66mm	312mm x 555mm x 66mm

Declaration of Conformity



We, Harman Consumer International
2, route de Tours
72500 Chateau-du-Loir
FRANCE

declare in own responsibility, that the product described in this owner's manual is in compliance with technical standards:

EN 55013/A14:1999
EN 55020/A14:1999

Emmanuel Millot
Harman Consumer
International
Chateau-du-Loir, France 5/03

* BPx500.1, BPx1100.1 and BPx2200.1 amplifiers are performance-engineered by Crown.

JBL Consumer Products

250 Crossways Park Drive, Woodbury, NY 11797 USA

© 2003 Harman International Industries, Incorporated

JBL and Power Series are registered trademarks, and Dynamic Bass Optimizer is a trademark, of Harman International Industries, Incorporated.

Part No. PSAMPOM5/03

H A Harman International Company

www.jbl.com