

# Bassman<sup>®</sup> 500



OWNER'S MANUAL | MANUAL DE INSTRUCCIONES  
MODE D'EMPLOI | MANUAL DO PROPRIETÁRIO  
MANUALE UTENTE | BEDIENUNGSHANDBUCH  
INSTRUKCJA OBSŁUGI | NÁVOD K POUŽITÍ  
NÁVOD NA POUŽITIE | UPORABNIŠKI PRIROČNIK  
オーナーズ・マニュアル | 用户手册

Fender<sup>®</sup>

# Bassman<sup>®</sup> 500

Thank you for choosing the Fender<sup>®</sup> Bassman<sup>®</sup> 500 watt hybrid (tube preamp + class-D power amp) bass head. This amplifier was designed to provide the ultimate bass playing experience, with two channels (Vintage/Overdrive), classic good looks and modern technology designed to maximize classic technology.

The Vintage channel offers a classic Fender passive tone stack. This "cut-only" interactive circuit provides a distinctly old-school caramel-like thickness to the notes. The Overdrive channel has an active tone stack, very quick and responsive, with the ability to get incredibly aggressive. Foot switch between these on stage for an instant tone make-over.

Silent recording is easy. Simply disconnect any connected speaker cabinet and capture the Preamp tone out of the XLR output without waking the neighbors!

The Bassman 500 will provide a lifetime of thick, natural, balanced tone that sits fat in your live or studio mix. Enjoy!

**PRODUCT REGISTRATION** — Please visit: [www.fender.com/product-registration](http://www.fender.com/product-registration)

## Front Panel

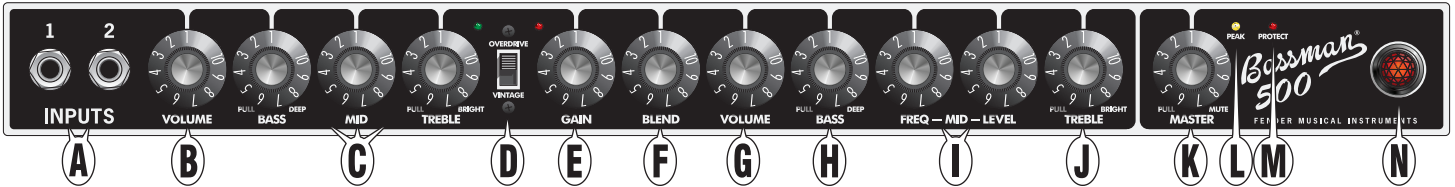

**A. INPUTS** — Plug your bass into the input that sounds the best to you! input "2" is a lower sensitivity input (-6db) and provides cleaner response with high-output or active instruments. if both inputs are used simultaneously, their input sensitivities become identical, both -6db.

**B. VOLUME** — Adjusts the volume level of the Vintage channel.

**C. BASS / MID / TREBLE** — Classic, cut-only (passive) tone stack. Pull the BASS knob out for emphasis in the low-frequency range (DEEP). Pull the TREBLE knob out for an increase in the high-frequency range (BRIGHT).

**D. CHANNEL SELECT** — Selects the active channel as indicated by the green and red LEDs. When the VINTAGE channel is selected (switch in the down position, green LED), the knobs on the left {B-C} are active. When the OVERDRIVE channel is selected (switch in the up position, red LED), the knobs on the right {E-J} are active.

*The included Footswitch can also be used to select channels. See FOOTSWITCH {R} on next page.*

**E. GAIN** — Adjusts the amount of preamp tube distortion in the overdrive channel.

**F. BLEND** — Controls the amount of distorted signal (set by GAIN) to be blended with the clean bass signal. Lower settings can maintain a cleaner tone, with some added grit. Higher settings will produce more distorted tones and add sustain. Set to "1" for clean tube bass signal only.

**G. VOLUME** — Adjusts the volume level of the Overdrive channel. Use together with the GAIN knob {E} to set the overall loudness of the Overdrive channel.

**H. BASS** — Adjusts the amount of low-frequency boost or cut ( $\pm 15\text{dB}$ ) of the Overdrive channel. Set this knob to the center detent position for flat bass response. Pull this knob out for low-frequency emphasis (DEEP).

**I. MID FREQ / MID LEVEL** — Use the FREQ knob to set the frequency at which the LEVEL knob adjusts the middle-frequency boost or cut ( $\pm 18\text{dB}$ ) of the Overdrive channel. Set the LEVEL knob to the center detent position for flat mid response.

*It is easiest to adjust MID when the LEVEL control is at its maximum or minimum, so that the effect of the FREQ knob is more easily heard. Once the proper FREQ setting is found, adjust the LEVEL knob to the desired setting.*

**J. TREBLE** — Adjusts the amount of high-frequency boost or cut ( $\pm 15\text{dB}$ ) of the Overdrive channel. Set this knob to the center detent position for flat treble response. Pull this knob out for a high-frequency boost (BRIGHT).

**K. MASTER** — Adjusts the overall volume of the amplifier. Pull this knob out to mute all outputs from the amp except the TUNER output, useful for silent instrument tuning.

*Bassman amps are equipped with Fender's Delta-Comp™ limiter. Setting the MASTER level higher or playing more aggressively will result in more compression and sustain!*

**L. PEAK** — This LED illuminates when the amplifier is producing maximum peak power (reaching the limiter threshold). To avoid overheating the class-D power amplifier, reduce the output level to where the PEAK LED is flashing during playing rather than being on continuously for extended periods.

**M. PROTECT** — This LED illuminates when the class-D amplifier has gone into protect mode due to exceeding safe operating temperature or maximum current limit (i.e. operating at 2-ohms). This LED also illuminates briefly during power on. The speaker output will be muted when this led is on.

**N. POWER INDICATOR** — Illuminates when power to the unit is switched on.

**NOTE:** The TUNER OUT {S}, POWER AMP IN and PRE AMP OUT {T} jacks are balanced TRS (Tip/Ring/Sleeve) type jacks, with tip=positive (+), ring=negative (-) and sleeve=ground (GND). While standard shielded TS (Tip/Sleeve) "mono" guitar cables can certainly be used, the use of "stereo" TRS cables may improve signal-to-noise ratio and reduce hum due to line noise.

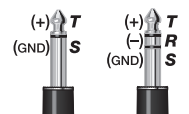

## Rear Panel

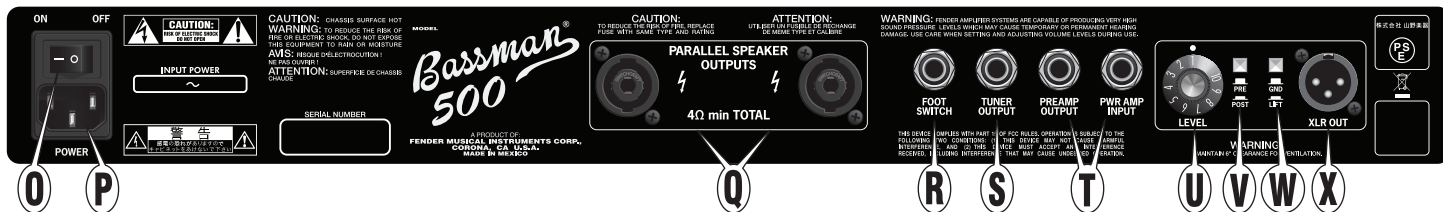

- O. POWER SWITCH** — Press to the "ON" position to switch the amplifier on. Press to the "OFF" position to switch the amplifier off.
- P. IEC POWER INLET** — Connect to a grounded outlet in accordance with the INPUT POWER voltage and frequency specified next to the power inlet on your amplifier.
- Q. PARALLEL SPEAKER OUTPUTS** — Connect speaker cabinets here.

 *Bassman 500 amps are equipped with combination speaker output jacks which allow you to use Speakon® or 1/4" (6.3 mm) speaker cables.*

The power rating of the external cabinets should meet or exceed the rating listed on the amplifier. The MINIMUM impedance of all connected speaker cabinets is 4Ω. The following list shows some acceptable parallel speaker cabinet combinations:

SPEAKER COMBINATIONS	TOTAL IMPEDANCE
4Ω	4Ω
8Ω	8Ω
8Ω + 8Ω	4Ω
8Ω + 16Ω	5.33Ω
8Ω + 16Ω + 16Ω	4Ω
16Ω + 16Ω	8Ω
16Ω + 16Ω + 16Ω + 16Ω	4Ω

**IMPORTANT NOTE:** Bassman 500 amplifiers include a digital power amplifier that operates in bridge mode. Both the tip (+) and sleeve (-) have voltage present, so never ground either the tip (+) or sleeve (-) of the speaker cable. Always make connections with the power turned off, and use care when making connections with cables that have non-insulated (bare metal) type plugs. Using speaker cables with insulated bodies is preferred, but not required.

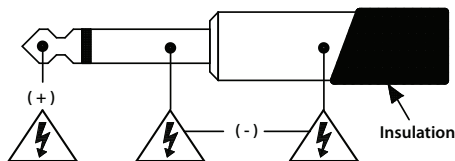

- R. FOOTSWITCH** — Plug the included footswitch in here to enable remote channel switching. When the footswitch is connected, the front panel CHANNEL SELECT switch {D} is disabled, but the channel indicator LEDs will operate normally.
- S. TUNER** — Connect your instrument tuner here.
- T. PREAMP OUT / POWER AMP IN** — Multi-functional input/output jacks that can be used in a variety of configurations:
  - 1) **Effects Loop** — Connect PREAMP OUTPUT to the input of your effects device and connect PWR AMP INPUT to the output jack of your effects device. The signal level here is nominally line level (+4dBu) and is most suitable for professional rack-style effects. MASTER {K} affects the send level, and the effects device controls the return level.
  - 2) **Multiple Bassman® Amps** — Connect PREAMP OUTPUT on the primary unit to POWER AMP IN on an auxiliary unit. The knobs on the primary unit control the auxiliary unit.
- U. LEVEL** — Use to adjust the output level of the XLR OUT jack {X} to accommodate the input sensitivities of outboard sound equipment.
- V. PRE / POST** — Select "POST" to include all preamp signal adjustments {B–C or E–J} in the XLR OUT signal. Select "PRE" for a DIRECT tube driven signal, unaffected by preamp controls.
- W. GROUND / LIFT** — Select "LIFT" to disconnect the ground connection on the XLR OUT jack which may reduce hum or line noise in some situations. Normally leave this button out, in the "GND" (grounded) position.
- X. XLR OUT** — A balanced, line level output for connection to mixing consoles and recording equipment. Disconnect speakers {Q} for silent recording.

## Thermal Performance & Protection

Bassman 500 amplifiers are equipped with variable speed fan cooling and thermal shutdown protection. The fan will start at a low speed and increase as you play harder. **Leave at least 6 inches of clearance in the front and rear of your amplifier and do not block the vents underneath the electronics chassis with cables or other objects stored in the cabinet.** If the amplifier vents are blocked, or it is used in an extremely hot environment, the class-D amplifier may overheat and enter thermal protection causing the PROTECT LED to illuminate

and the speaker output to mute temporarily. In the event of an output short circuit or over current situation (i.e. operating below minimum impedance) the class-D amplifier will enter protection causing the PROTECT LED to illuminate and the speaker output to mute temporarily. The class-D amplifier will automatically resume operation within a few seconds, when it has returned to a safe operating temperature and the fault has been removed.

## Tube Replacement

The Bassman® uses the following types of tubes:

**Pre-Amplifier:** Two 12AX7A tubes (V1, V2)

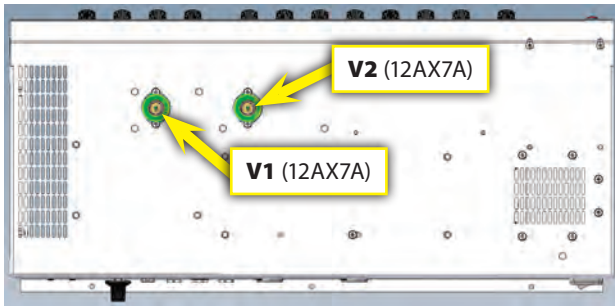

(Chassis, bottom view)

If your amplifier is not performing as it should, refer to the Troubleshooting section below. Generally speaking with most tube audio amplifiers the tubes are the most likely thing to fail and may be replaced without taking your amplifier to a qualified service technician. If any tubes need replacing, carefully read and follow these steps. If you do not feel comfortable replacing your amplifier's tubes, take it to an authorized Fender service center. All other service needs should be referred to an authorized Fender service center. There are no user serviceable parts inside the electronics chassis. Lethal voltages exist inside your tube amplifier! Tube amplifier components get very hot! Failure to follow all these instructions may result in damage to your amplifier, or personal injury!

### How to Replace the Tubes on your amplifier:

- 1) Turn off the amplifier and remove the power cable from the IEC inlet {P}. You might also want to disconnect other cables (such as the speaker, line-out, effects loop, etc) so that they are not in the way.
- 2) Caution! The tubes get very hot during operation and may cause burn injuries. Wait for the amplifier to cool down before proceeding to the next step.

- 3) After the amplifier has cooled down, to gain access to the preamp tubes use a #2 Phillips screw driver to remove the 4 nickel screws holding the rear grille.
- 5) You now have access to the tubes. Preamp tubes have metal shields that must be twisted and pulled down to remove them. Pull the tubes straight down to remove them. **Caution:** Excessive side-to-side motion could cause the Locator-Pin on the bottom of the tube to fracture in the socket, which will not be covered by the Fender Electronic Product Warranty to remove. If you are uncomfortable in performing this process please seek the assistance of an Authorized Fender Electronics Service Center.
- 9) Replace the rear grille and install the four nickel mounting screws.
- 10) Reconnect the speaker cable and any other signal cables you disconnected in step 1.
- 11) Reconnect the power cable.

### Note on Handling Tubes:

It is important not to leave fingerprints, grease, or other foreign substances on the glass surface of the tubes. This is especially important for the power output tubes. If fingerprints or other substances are left on the surface of the tube, they will cause the tube to become hotter than normal in that spot, which can lead to cracks in the glass and premature failure of the tube. Some people recommend not touching the tubes with bare hands at all. However, it is usually impossible to avoid. Take the following steps to ensure that the tubes are clean and will have the maximum possible life:



- 1) Wash your hands before handling the tubes.
- 2) Avoid excess handling of the tubes.
- 3) After installation of the tubes, wipe them with a clean cloth to remove any fingerprints or foreign substances.

## Troubleshooting

**PROBLEM:** I cannot hear any sound coming out of my Bassman, but my instrument is plugged in and the power to the amplifier is turned on and the red jewel {N} on the front is glowing.

### SOLUTIONS:

- Make sure the VOLUME knobs {B and G} and MASTER Volume {K} are set above "1."
- Make sure that the MASTER Volume knob {K} is pressed in (defeat "MUTE").
- If outboard gear is connected in the effects loop {T} (between PREAMP OUTPUT and PWR AMP INPUT) make sure it is turned on and functioning. If unplugging the cable from the PWR AMP INPUT jack solves the problem, the problem is in the outboard gear in the effect loop, not with the Bassman.
- Verify that the speaker cable is connected properly between the PARALLEL SPEAKER OUTPUTS {Q} and speaker cabinets.
- Try replacing the speaker and instrument cables.
- Try a different instrument.

If none of these solutions solve the problem, investigate the pre-amp tubes (see below).

**PROBLEM:** No sound is coming from the amplifier when the instrument is connected to INPUT {A}, but the amplifier DOES work when connecting the instrument directly into the POWER AMP INPUT {V}.

**SOLUTIONS:** One of the preamp tubes V1 or V2 (both 12AX7) is bad. If the amplifier works normally in the 'VINTAGE' channel, but does not work properly in the 'OVERDRIVE' channel (unless BLEND {F} is set to "1"), replace preamp tube V2 with a new tube. Otherwise, replace preamp tube V1 with a new tube.

**PROBLEM:** Amplifier feeds back creating a loud high-pitched sound, even when no instrument is connected, and especially when Volume, Gain, or tone controls are at high settings in either channel. -OR- The amplifier creates unintentional ringing noises, which sound like chimes, while playing certain notes. -OR- Mechanical noises like tapping on the amplifier chassis (i.e. with a pick or drumstick) are picked up and amplified through the speakers.

**SOLUTIONS:** Preamp tubes are becoming "microphonic." Replace V1 and/ or V2 (both 12AX7) with a new tube. If the problem only occurs in the 'OVERDRIVE' channel, try replacing V2 first.

# Block Diagram

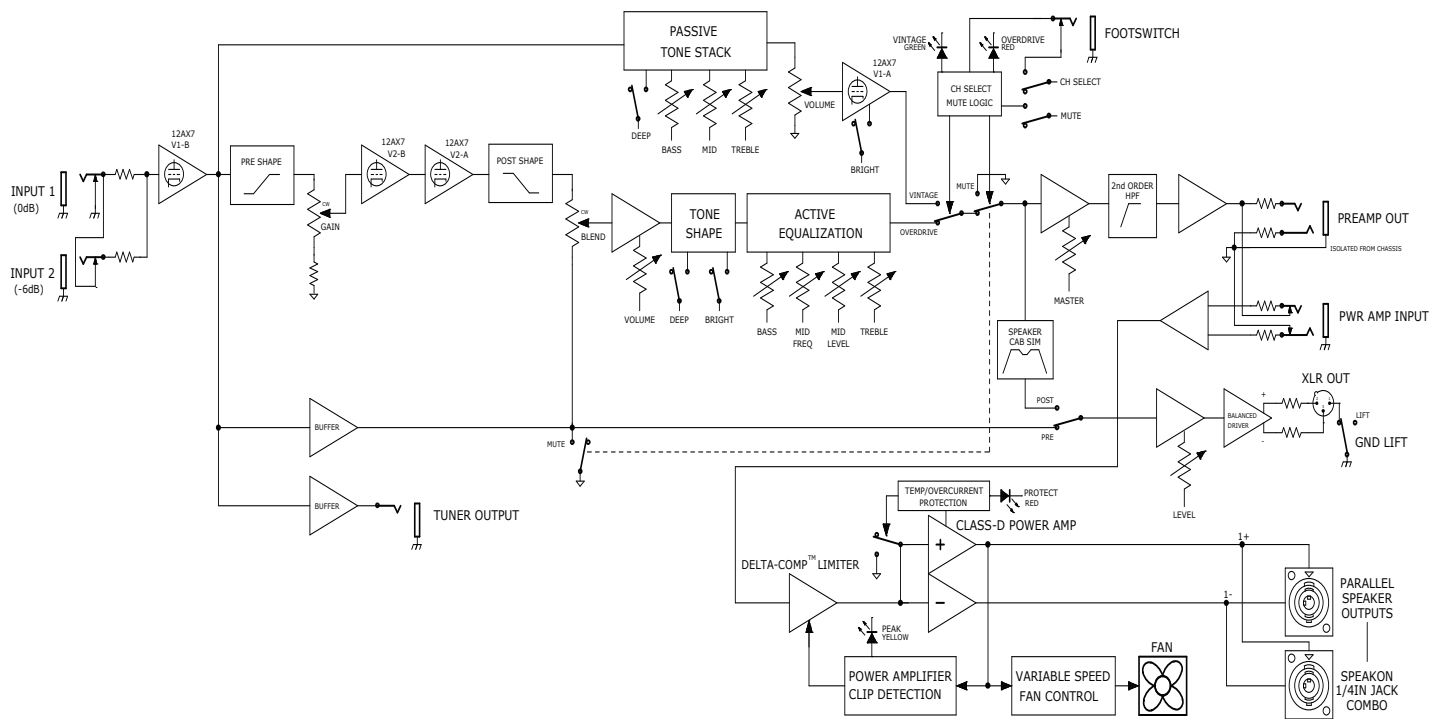

## Specifications

<b>MODEL:</b>	<b>Bassman 500</b>
<b>TYPE:</b>	PR 2809
<b>POWER</b>	<b>REQUIREMENTS:</b> 950W <b>OUTPUT:</b> 350W into 8Ω 500W into 4Ω
<b>INPUT IMPEDANCES</b>	<b>INPUT 1:</b> >820kΩ <b>INPUT 2:</b> 136kΩ (-6dB) <b>POWER AMP:</b> 20kΩ (balanced)
<b>OUTPUT IMPEDANCES</b>	<b>XLR OUT:</b> 50Ω (balanced) <b>TUNER:</b> 220Ω (balanced) <b>PREAMP:</b> 220Ω (balanced)
<b>tone Controls VINTAGE</b>	<b>BASS:</b> 10dB range @ 40Hz (MID: 5, TREBLE: 5) <b>MID:</b> 15dB range @ 400Hz (BASS: 5, TREBLE: 5) <b>TREBLE:</b> 9dB range @ 4kHz (BASS: 5, MID: 5)
<b>tone Controls OVERDRIVE</b>	<b>BASS:</b> ±15dB @ 80Hz (Deep: -18dB @ 640Hz) <b>MID LEVEL/FREQ:</b> ±18dB @ 200Hz to 3.3kHz <b>TREBLE:</b> ±15dB @ 4kHz (Bright: +10dB @ 6kHz)
<b>SPEAKERS (RECOMMENDED):</b>	Bassman 810 (P/N: 2249200000) Bassman 610 (P/N: 2249300000) Bassman 410 (P/N: 2249400000) Bassman 115 (P/N: 2249500000)
<b>TUBES:</b>	Two 12AX7A (P/N: 0013341000)
<b>ACCESSORIES (INCLUDED)</b>	<b>FOOTSWITCH:</b> 1-button, Vintage (P/N: 0057172000)
<b>DIMENSIONS</b>	<b>HEIGHT:</b> 8.6 in (21.7 cm) <b>WIDTH:</b> 22.7 in (57.6 cm) <b>DEPTH:</b> 10.5 in (26.7 cm)
<b>WEIGHT:</b>	17 lb (7.7 kg)



Product specifications are subject to change without notice.

**PART NUMBERS / REFERENCIAS / RÉFÉRENCE / NÚMERO DAS PEÇAS / NUMERO PARTI / TEILENUMMERN  
NUMERY REFERENCYJNE / REFERENČNÍ ČÍSLA / REFERENČNÉ ČÍSLA / REFERENČNE ŠTEVILKE / 部品番号 / 型号**

**Bassman 500**

2249600000 (120V, 60Hz)  
2249601000 (110V, 60Hz) TW  
2249603000 (240V, 50Hz) AU  
2249604000 (230V, 50Hz) UK  
2249605000 (220V, 50Hz) ARG  
2249606000 (230V, 50Hz) EU  
2249607000 (100V, 50/60Hz) JP  
2249608000 (220V, 50Hz) CN  
2249609000 (220V, 60Hz) ROK  
2249613000 (240V, 50Hz) MA

部件名称 (Part Name)	有毒有害物质或元素 (Hazardous Substances' Name)					
	铅 (PB)	汞 (Hg)	镉 (Cd)	六价铬 (Cr <sup>6+</sup> )	多溴联苯 (PBB)	多溴二苯醚 (PBDE)
部分电子元件	X	O	O	O	O	O
部分机器加工金属部件	X	O	O	O	O	O
部分其他附属部件	X	O	O	O	O	O

O: 表示该有毒有害物质在该部件所有均质材料中的含量均在 SJ/T 11363-2006 规定的现量要求以下  
X: 表示该有毒有害物质至少在该部件的某一均质材料中的含量超出 SJ/T 11363-2006 规定的现量要求

**AMPLIFICADOR DE AUDIO**

IMPORTADO POR: Fender Ventas de México, S. de R.L. de C.V.  
Calle Huerta #279, Int. A. Col. El Naranjo. C.P. 22785. Ensenada, Baja California, México.  
RFC: FVM-140508-CIO  
Servicio al Cliente: 01(800) 7887395, 01(800) 7887396, 01(800) 7889433

A PRODUCT OF:

**FENDER MUSICAL INSTRUMENTS CORPORATION  
CORONA, CALIFORNIA, USA**

Fender®, Bassman® and Delta-Comp™ are trademarks of FMIC.  
Other trademarks are property of their respective owners.  
Copyright © 2014 FMIC. All rights reserved.

P/N 7707241000 REV A