

# Cuisinart®

## INSTRUCTION AND RECIPE BOOKLET



### Pizzelle Press

### WM-PZ2

For your safety and continued enjoyment of this product, always read the instruction book carefully before using.

---

## TABLE OF CONTENTS

Important Safeguards .....	2
Instructions for Use .....	3
Special Features.....	3
Tips & Hints .....	4
Recipes.....	5
Cleaning and Maintenance .....	7
Storage.....	7
Warranty .....	7

## IMPORTANT SAFEGUARDS

When using an electrical appliance, basic safety precautions should always be followed, including the following:

1. READ ALL INSTRUCTIONS.
2. Do not touch hot surfaces. Use handles and knobs.
3. To protect against fire, electrical shock, and injury to persons, DO NOT IMMERSE CORD, PLUG, OR UNIT in water or other liquids.
4. Close supervision is necessary when any appliance is used by or near children.
5. Unplug from outlet when not in use and before cleaning. Allow to cool before putting on or taking off parts, and before cleaning appliance.
6. Do not operate any appliance with a damaged cord or plug, or after the appliance malfunctions or has been damaged in any manner. Return appliance to the nearest Cuisinart Authorized Service Facility for examination, repair, or adjustment.
7. The use of accessory attachments not recommended by Cuisinart may result in fire, electrical shock, or injury to persons.
8. Do not use outdoors.
9. Do not let power cord hang over edge of table or counter, or touch hot surfaces.
10. Do not place on or near a hot gas or electric burner, or in a heated oven.
11. Unplug the unit when finished pressing pizzelle.
12. Do not use appliance for other than intended use.

13. Extreme caution must be used when moving an appliance containing hot oil or other hot liquids.
14. Always attach plug to appliance first, then plug cord into the wall outlet. To disconnect, turn control to setting #1, then remove plug from wall outlet.
15. **WARNING: TO REDUCE THE RISK OF FIRE OR ELECTRIC SHOCK, REPAIR SHOULD BE DONE ONLY BY AUTHORIZED PERSONNEL. DO NOT REMOVE THE BASE PANEL. NO USER SERVICEABLE PARTS ARE INSIDE.**

## SAVE THESE INSTRUCTIONS FOR HOUSEHOLD USE ONLY

### SPECIAL CORD SET INSTRUCTIONS

A short power-supply cord is provided to reduce the risks resulting from becoming entangled in or tripping over a longer cord.

Longer extension cords are available and may be used if care is exercised in their use.

If a long extension cord is used, the marked electrical rating of the extension cord should be at least as great as the electrical rating of the appliance, and the longer cord should be arranged so that it will not drape over the countertop or tabletop where it can be pulled on by children or animals, or tripped over.

### NOTICE:

This appliance has a polarized plug (one blade is wider than the other). To reduce the risk of electric shock, this plug will fit in a polarized outlet only one way. If the plug does not fit fully in the outlet, reverse the plug. If it still does not fit, contact a qualified electrician. Do not modify the plug in any way.

## INSTRUCTIONS FOR USE

1. Before using your Cuisinart® Pizzelle Press for the first time, remove all protective paper and wrapping. Remove any dust from shipping by wiping the plates with a damp cloth.
2. Preheat the Pizzelle Press. Close lid and plug cord into a 120V AC wall outlet. The red light will go on to signal power. The green indicator light will go on when the unit is ready to use.

Note: The first time you use your Pizzelle Press, it may have a slight odor and may smoke a bit. This is normal, and common to appliances with a nonstick surface.

3. When the green indicator light goes on, scoop ingredients onto bottom plates according to the recipes provided. Close the lid and lock down the latch to hold the plates closely together.
4. The green light will go off and the red light will illuminate again. It may take several seconds for the red light to come on. This is normal.
5. Once the pizzelle are ready to be removed from the unit, the green light will illuminate once again. Baking time is determined by browning level. Choose a setting on the browning control dial. For golden crisp pizzelle, we recommend using setting #3 or #4.
6. Unlatch the plates and lift the top cover. Remove the pizzelle by loosening the edges with a heat-resistant plastic spatula. Never use metal utensils, as they may damage the nonstick coating.
7. Always disconnect the plug from the wall outlet, once cooking has been completed.

## SPECIAL FEATURES

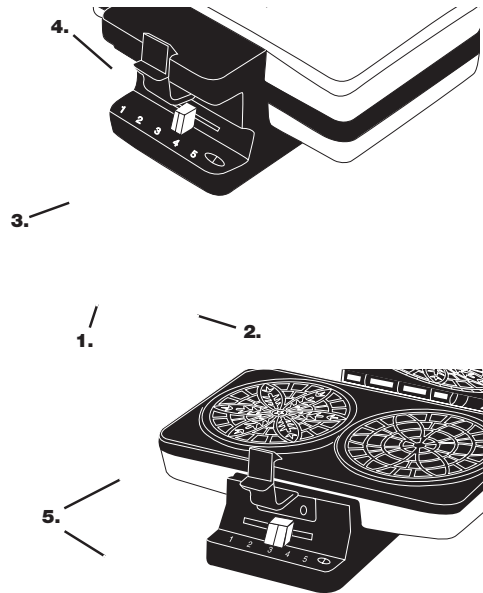

- 1. Browning Control Adjustment**
  - Five settings to customize pizzelle, from light to deep golden brown.
- 2. Indicator Lights**
  - Signal when pizzelle press is ready to bake, and when the pizzelle are ready to eat.
- 3. Lockdown Latch**
  - Holds plates closely together, to prevent lifting during cooking.
- 4. Brushed Stainless Steel Housing**
- 5. Pizzelle Plates**
- 6. Rubber Feet (Not Shown)**
  - Keep unit steady without marking the countertop.
- 7. Cord Storage (Not Shown)**
  - Cord wraps around base for easy storage.
- 8. BPA-Free (Not Shown)**
  - All parts that come in contact with food are BPA-Free.

---

Note: This Pizzelle Press has been treated with a special nonstick coating. Before the first use, we suggest you season the grids with cooking spray or oil. If using oil, apply with a paper towel or pastry brush. You may find it helpful to repeat this process before each use of the pizzelle press.

## TIPS & HINTS

Always allow the Cuisinart® Pizzelle Press to preheat completely before baking pizzelle.

Make certain that the green indicator light is lit before baking subsequent batches of pizzelle.

Be certain that the Pizzelle Press is completely clean before preheating. Crumbs and batter baked onto the press will cause sticking.

Use a small amount of vegetable oil or melted vegetable shortening applied with a heatproof pastry brush to lightly condition the press. Butter will burn or smoke when heated, and many cooking sprays contain lecithin, which can become “gummy” and sticky when heated on a nonstick cooking surface.

If you are rolling your pizzelle, roll them immediately upon removing them from the press. Remove one pizzelle at a time, allowing the second to remain on the hot press (allow to remain open) while rolling.

Hot pizzelle can be molded around the cylinder provided or a small custard cup or ramekin to create a cup. Shaped pizzelle should be filled just before serving.

Lighter pizzelle are easier to roll/mold than darker pizzelle.

If pizzelle run over the edges of the mold, trim while warm with a sharp knife or kitchen scissors.

Allow pizzelle to cool completely on a wire rack before storing.

In a dry climate, store pizzelle in a shallow cookie jar or container with loose-fitting lid. Add a layer of paper towel between each cookie to absorb excess moisture. In a humid climate, store pizzelle in a tightly covered container.

Pizzelle can be frozen. Stack in small bundles with a sheet of paper towel between each cookie, wrap in plastic wrap, then place in a resealable food storage bag and squeeze out excess air.

If pizzelle become soft, arrange them in a single layer on a cookie sheet. Place in a 300°F oven for 3 to 5 minutes.

Many pizzelle batters may be prepared ahead, covered tightly and stored in the refrigerator for up to 24 hours before baking pizzelle.

“Center” the batter just a little behind the direct center of each patterned cookie grid, so that when the lid is closed it will push the batter forward to the center, making a more evenly rounded pizzelle.

When finished baking pizzelle, unplug unit and open to cool completely. Brush any residual crumbs from the press, paying particular attention to the pattern indentations, using a soft brush such as a new toothbrush, pastry brush (do not use a brush with any metal wire, such as a bottle brush), or cotton swab. Then wipe the unit with a dampened soft cloth, such as a microfiber cloth (available in most kitchenware/gourmet stores), to remove all grease and crumbs. Allow unit to dry completely before storing.

About the Recipes:

Many pizzelle recipes can be mixed ahead of time, covered and refrigerated. Remove batter from refrigerator about 30 minutes before baking.

It is important to measure flour and other dry ingredients properly for best baking results. Use nested measuring cups of graduated sizes – do not use measuring cups meant for liquid measurements. Stir flour before measuring, then spoon or scoop into the measuring cup and level with the straight edge of a spatula or table knife.

Nutritional information is based on number of servings indicated. If a recipe produces a range of servings, it is based on the highest serving yield for that particular recipe. If a recipe has a lower fat option, that is the one used for nutritional information.

---

# RECIPES

## CLASSIC PIZZELLE

Our basic pizzelle recipe is flavored with the universally popular vanilla. You may vary the taste by using other flavors such as anise, almond or lemon extract.

Makes 36 - 40 pizzelle

- 1-3/4 cups all-purpose flour
- 2 teaspoons baking powder
- 3 large eggs
- 3/4 cup granulated sugar
- 1/2 cup unsalted butter, melted
- 1 tablespoon vanilla extract or anise extract

Preheat the Cuisinart® Pizzelle Press on Setting 3 while preparing the batter.

Place flour and baking powder in a small bowl and stir to combine; reserve. Place eggs and sugar in a medium bowl. Using a Cuisinart® SmartPower™ Hand Mixer, mix on medium speed for 1 minute, until thickened. On low speed, add the melted butter and vanilla in a steady stream and mix until combined, about 15 seconds. Add the flour mixture and mix until just combined, about 10 to 15 seconds; do not overmix.

It may be necessary to lightly brush both the top and bottom grids with a flavorless vegetable oil or melted vegetable shortening before baking. Use the spoon provided to scoop the dough, about 1-1/2 – 2 teaspoons, and drop onto one of the patterned cookie grids; repeat to make a second cookie. Close the lid and lock. The red indicator light will come on. When the red indicator light goes out and the green indicator light comes on, the pizzelle are ready. For a lighter colored pizzelle, bake for a shorter time; for darker pizzelle, add a few more seconds. Remove pizzelle from the press using a heat-proof plastic spatula and place on a rack to cool completely. Warm pizzelle may be wrapped around the dowel provided to form cannoli shells. Completely cooled pizzelle may be dusted with powdered sugar before serving.

Nutritional information per pizzelle:

Calories 60 (40% from fat) • carb. 8g • pro. 1g • fat 3g • sat. fat 2g • chol. 22mg • sod. 17mg • calc. 3mg • fiber 0g

Variations:

Marble Pizzelle: Add 2 ounces finely chopped bittersweet or semisweet chocolate to the batter. Bake as directed.

## DOUBLE CHOCOLATE PIZZELLE

While chocolate pizzelle are not traditional, they are quite delicious. Use with your favorite ice cream to make ice cream sandwiches.

Makes 36 - 40 pizzelle

- 1-1/2 cups all-purpose flour
- 1/4 cup unsweetened cocoa powder
- 2 ounces very finely chopped bittersweet or semisweet chocolate
- 2 teaspoons baking powder
- 3 large eggs
- 1 cup granulated sugar
- 1/2 cup unsalted butter, melted
- 1 tablespoon vanilla extract

Preheat the Cuisinart® Pizzelle Press on Setting 3 while preparing the batter.

Place flour, cocoa, chopped chocolate, and baking powder in a small bowl and stir with a whisk or fork to combine; reserve. Place eggs and sugar in a medium bowl. Using a Cuisinart® SmartPower™ Hand Mixer, mix on medium speed for 1 minute, until thickened. On low speed, add the melted butter and vanilla in a steady stream and mix until combined, about 15 seconds. Add the flour mixture and mix until just combined, about 10 to 15 seconds; do not overmix.

It may be necessary to lightly brush both the top and bottom grids with a flavorless vegetable oil or melted vegetable shortening before baking. Use the spoon provided to scoop the dough, about 1-1/2 – 2 teaspoons, and drop onto one of the patterned cookie grids; repeat to make a second cookie. Close the lid and lock. The red indicator light will come on. When the red

indicator light goes out and the green indicator light comes on, the pizzelle are ready. Adjust baking times for softer or crispier cookies, according to personal preference. Remove pizzelle from the press using a heatproof plastic spatula and place on a rack to cool completely. Warm pizzelle may be wrapped around the dowel provided to form cannoli shells. Completely cooled pizzelle may be dusted with powdered sugar before serving.

Nutritional information per pizzelle:

Calories 71 (41% from fat) • carb. 10g • pro. 1g • fat 3g • sat. fat 2g • chol. 22mg • sod. 17mg • calc. 4mg • fiber 0g

Variation:

Mocha Almond Pizzelle: Dissolve 1 tablespoon instant espresso powder in 2 tablespoons hot water. Add to batter along with 1/3 cup finely ground almonds. Use 1-1/2 teaspoons each of almond and vanilla extracts in place of 1 tablespoon vanilla extract.

### HAZELNUT PIZZELLE

This delicately flavored cookie is delightful to serve with after-dinner coffee.

Makes 36 - 40 pizzelle

- 1-3/4 cups all-purpose flour
- 2 ounces finely ground blanched hazelnuts (1/2 cup)\*
- 2 teaspoons baking powder
- 3 large eggs
- 3/4 cup granulated sugar
- 1/2 cup unsalted butter, melted
- 1 tablespoon Frangelico liqueur
- 2 teaspoons vanilla extract

Preheat the Cuisinart® Pizzelle Press on Setting 3 while preparing the batter.

Place flour, ground nuts and baking powder in a small bowl and stir with a whisk or fork to combine; reserve. Place eggs and sugar in a

medium bowl. Using a Cuisinart® SmartPower™ Hand Mixer, mix on medium speed for 1 minute, until thick. On low speed, add the melted butter and vanilla in a steady stream and mix until combined, about 15 seconds. Add the flour mixture and mix until just combined, about 10 to 15 seconds; do not overmix.

It may be necessary to lightly brush both the top and bottom grids of the Pizzelle Press with a flavorless vegetable oil or melted vegetable shortening before baking. Use the spoon provided to scoop the dough, about 1-1/2 – 2 teaspoons, and drop onto one of the patterned cookie grids; repeat to make a second cookie. Close the lid and lock. The red indicator light will come on. When the red indicator light goes out and the green indicator light comes on, the pizzelle are ready. For a lighter colored pizzelle, bake for a shorter time; for darker pizzelle, add a few more seconds. Remove pizzelle from the press using a heatproof plastic spatula and place on a rack to cool completely. Warm pizzelle may be wrapped around the dowel provided to form cannoli shells. Completely cooled pizzelle may be dusted with powdered sugar before serving.

Nutritional information per pizzelle:

Calories 71 (46% from fat) • carb. 8g • pro. 1g • fat 4g • sat. fat 2g • chol. 22mg • sod. 17mg • calc. 6mg • fiber 0g

Variation: You may vary the type of nut used. Try almond, pecan, walnut or pistachio. For Chocolate Marble Nut Pizzelle, add 2 ounces very finely chopped bittersweet or semisweet chocolate to the batter.

\*Grind nuts as finely as possible without turning into nut butter. This can be done easily in a Cuisinart® Food Processor or Mini-Prep® Plus Chopper/Grinder. You may wish to add a tablespoon of the sugar from the recipe to the nuts when chopping.



## CLEANING AND MAINTENANCE

Once you have finished cooking, remove plug from electrical outlet. Leave top lid open so plates begin to cool. Be certain plates have cooled completely before cleaning.

Never take your Pizzelle Press apart for cleaning. Simply brush crumbs from grooves, and absorb any excess cooking oil by wiping with a dry cloth or paper towel.

You may clean the plates by wiping with a damp cloth, to prevent staining and sticking from batter or oil buildup. If batter adheres to plates, simply pour a little cooking oil onto the cooked batter and let stand approximately 5 minutes, thus allowing batter to soften for easy removal. **DO NOT POUR OIL ONTO PIZZELLE PLATES WHEN PLUGGED IN.**

To clean exterior, wipe with a soft dry cloth. Never use an abrasive cleanser or harsh pad. **NEVER IMMERSE CORD, PLUG OR UNIT IN WATER OR OTHER LIQUID.**

## STORAGE

Store with cord wrapped securely around base. For compact storage, stand Pizzelle Press upright on hinge end with Cuisinart logo upside down. The Pizzelle Press has been designed with a special latching feature, so lid stays closed during storage.



## WARRANTY LIMITED 90 DAY WARRANTY

This warranty is available to consumers only. You are a consumer if you own a Cuisinart® Pizzelle Press which was purchased at retail for personal, family or household use. Except as otherwise required under applicable law, this warranty is not available to retailers or other commercial purchasers or owners.

We warrant that your Cuisinart® Pizzelle Press will be free of defects in materials and workmanship under normal home use for 3 years from the date of original purchase.

We recommend that you visit our website, [www.cuisinart.com](http://www.cuisinart.com) for a fast, efficient way to complete your product registration. However, product registration does not eliminate the need for the consumer to maintain the original proof of purchase in order to obtain the warranty benefits. In the event that you do not have proof of purchase date, the purchase date for purposes of this warranty will be the date of manufacture.

If your Cuisinart® Pizzelle Press should prove to be defective within the warranty period, we will repair or, if we think necessary, replace it. To obtain warranty service, please call our Customer Service Center toll-free at 1-800-726-0190 or write to: Cuisinart, 7811 North Glen Harbor Blvd., Glendale, AZ 85307.

To facilitate the speed and accuracy of your return, enclose \$10.00 for shipping and handling. (California residents need only supply a proof of purchase and should call 1-800-726-0190 for shipping instructions.) Please be sure to include your return address, description of the product's defect, product serial number, and any other information pertinent to the return. Please pay by check or money order.

**NOTE:** For added protection and secure handling of any Cuisinart® product that is being returned, we recommend you use a traceable, insured delivery service. Cuisinart cannot be held responsible for in-transit damage or for packages that are not delivered to us. Lost and/or damaged products are not covered under warranty.

Your Cuisinart® Pizzelle Press has been manufactured to the strictest specifications and has been designed for use only with authorized accessories and replacement parts. This warranty expressly excludes any defects or damages caused by accessories, replacement parts or repair service other than those authorized by Cuisinart.

This warranty does not cover any damage caused by accident, misuse, shipment or other than ordinary household use.

This warranty excludes all incidental or consequential damages. Some states do not allow the exclusion or limitation of these damages, so they may not apply to you.

# Cuisinart®

S A V O R T H E G O O D L I F E®



Coffeemakers



Food  
Processors



Toaster Ovens



Blenders



Cookware



Ice Cream  
Makers

Cuisinart offers an extensive assortment of top quality products to make life in the kitchen easier than ever. Try some of our other countertop appliances and cookware, and Savor the Good Life®.

[www.cuisinart.com](http://www.cuisinart.com)

©2010 Cuisinart  
150 Milford Road  
East Windsor, NJ 08520  
Printed in China

Any other trademarks or service marks referred to herein are the trademarks or service marks of their respective owners.

10CE114763

IB-4271B