

WARNING: Do not drill mounting holes with speaker in place, as this could allow drill shavings to damage the voice coil.

Always ensure the audio system is turned off before making any connections to the amplifier, speakers, crossover or source unit. Failure to do so could result in permanent damage to the audio system.

When wiring the speakers, ensure that the wire is protected from sharp metal objects, and always use rubber grommets when wire through metal panels. Ensure all terminals and connections are protected from the vehicle chassis and from each other.

When connecting the source unit/amplifier crossover and speakers, you connect the positive and negative output wire from the source unit/amplifier or crossover, to the corresponding speaker terminals. This will ensure the audio system will be in correct phase.

For further product and installation information please visit www.fusionelectronics.com

Para obtener más información sobre los productos o su instalación, visite www.fusionelectronics.com

Weitere Informationen zum Produkt und zur Installation finden Sie auf folgender Website: www.fusionelectronics.com

Ga naar www.fusionelectronics.com voor meer product- en montage-informatie

Pour plus de renseignements sur les produits et l'installation, veuillez consulter www.fusionelectronics.com

Per ulteriori informazioni su prodotto e installazione, potete visitare www.fusionelectronics.com

За дополнительной информацией о продукции и установке обращайтесь на www.fusionelectronics.com

RECORD YOUR PURCHASE DETAILS HERE:

MODEL NUMBER _____ DATE OF PURCHASE _____

AFFIX RECEIPT HERE

WARNING! Audio Systems can produce sound levels over 135dB. Continuous exposure to sound pressure levels over 100dB may cause permanent hearing loss! Please watch for emergency vehicles as warning signals may not be heard. USE COMMON SENSE!

YOU CAN HELP PROTECT THE ENVIRONMENT!
Please remember to respect the local regulations:
Hand in the non-working electrical equipment
to an appropriate waste disposal center.



PUBLISHED BY FUSION ELECTRONICS LIMITED:
© Copyright 2008 by FUSION Electronics Limited.
All rights reserved. Specifications and design are
subject to change without notice.

WWW.FUSIONELECTRONICS.COM

FUSION[®]

POWERPLANT COMPONENT SPEAKERS

PP-CM525, PP-CM650

Speaker Parameters

	PP-CM5250	PP-CM650
Max Power Rating	210 Watts	280 Watts
RMS Power Rating	95 Watts	120 Watts
Frequency Response	50Hz - 22kHz	40Hz - 22kHz
Impedance	4 Ohms	4 Ohms
Sensitivity	90 dB	91 dB
Mounting Depth	60mm	65mm
Mounting Diameter	125mm	140mm

Crossover Specifications

2-way, passive Butterworth crossover network
12db/octave slope rates
Adjustable 3-point tweeter level
High pass 3.5kHz
Low pass 4.0kHz

Installation Guidelines

Before any wiring and installation is performed, FUSION recommends you first plan the complete installation process. Look at the wiring routing, speaker location, and fitment. Make sure you recheck the installation at completion.

A correct front stage and stereo image can be achieved by proper speaker placement. Ideally, speakers need to be positioned where the sound produced is directed at the occupants of the vehicle. The adjustable tweeter supplied with FUSION PowerPlant Component Speakers is designed to make this easier.

Fusion speakers have been designed to fit in many stock or factory positions in the vehicle FUSION recommends a location with sufficient air volume behind the speaker, for it to work within its frequency range.

Installation Warning

1. Ensure the vehicle 12 volt lead is removed from the battery before any equipment is connected.
2. Investigate the vehicle gas tanks, brake lines, and electrical wiring locations before you begin installation.
3. Attach the product securely to the vehicle to prevent damage in the event of an accident.
4. Ensure all wiring is protected to avoid damage or pinching of the cables.

Installation Guidelines:

Bass/mid speaker installation

1. Ensure there is adequate clearance and depth for the speaker to be mounted
2. Use the supplied template to mark out the correct diameter hole
3. Drill four holes for the mounting screws
4. Correctly connect the crossover to the speaker. Observe polarity. The striped wire is the positive.
5. Carefully study the mounting diagram before attempting to mount the speaker. Insert the speaker and grille frame and affix with the screws provided. Your PowerPlant speaker is provided with two choices of grille frame. The custom grille is screwed directly into the frame of the speaker (see diagram A on reverse side). For the mesh grille, first remove the mesh, then fit the speaker and the grille. The mesh is fitted last by simply pushing the tabs on the mesh into the self-locking slots in the grille frame. (see diagram B on reverse side).

WWW.FUSIONELECTRONICS.COM

FUSION[®]

Diagram A - mesh grille

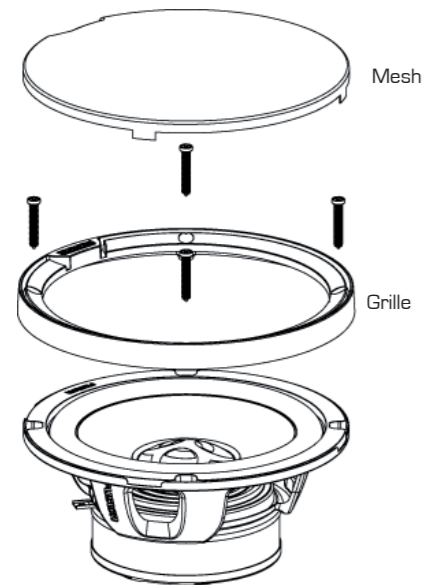
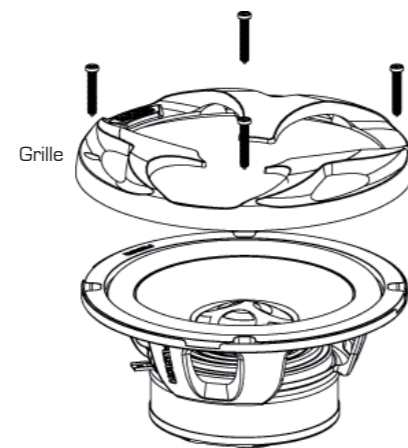

Diagram B - Custom grille



Tweeter Installation
Surface/angle mount

FUSION offers three choices of mounting styles to accommodate the varying requirements for on and off axis mounting positions. The most important goal for tweeter placement is the need to keep an un-obstructed path on axis to approximately 4" below the rear vision mirror. The reason for this is to enhance the perception of centre image. When mounting, make sure there is no wiring behind the mounting surface, use the tweeter mount that enables the best sound focus and use this as the template for drilling the mounting holes. Run the wiring back to the crossover.

Flush mount

First check that the tweeter can be flush mounted into the surface you have chosen, especially with regards to depth. Mark out a 50mm hole and cut this out. Having a hole saw will greatly improve the tidiness and the integrity of the hole. Assemble the rear mount with the spring clamp and press through from the rear of the mounting surface, then bayonet the front plate and the rear mount together as shown in the flush mount illustration. Run the wiring back to the crossover.

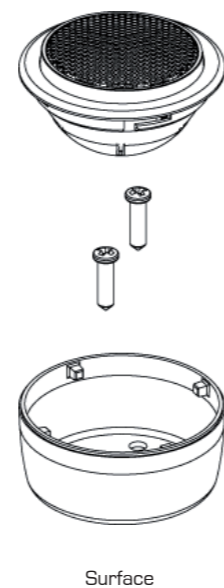
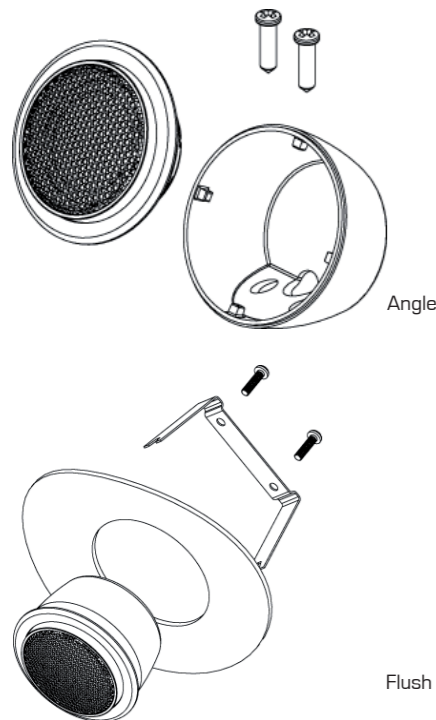

Crossover Installation

1. FUSION crossovers are manufactured specifically for use with the FUSION full range component system. Use of any other crossover may result in damage to one or more of the components.
2. The x-over is designed for installation under the vehicle dash, under the rear parcel shelf or in the trunk of the vehicle. They should not be located where they are subject to moisture, such as a leaky door. If possible locate the crossovers closer to the speakers than the amplifier.
3. Use the crossover to mark the mounting holes. Make sure there is sufficient clearance on the other side of the mounting surface and that the mounting surface is perfectly flat to avoid damage to the crossover.
4. Drill two pilot holes for the screws and wire the crossovers.
5. Cut the pre-run speaker cable to the correct length. Connect the cable to the crossover, ensure the correct polarity.
6. Screw into position.
7. Adjust the tweeter level by removing the lid and selecting the desired setting. There are three options available -3, 0, +3dB.

