

# 33 V2

## 330mm Polyglass subwoofer



- Zamak chassis, 4 layers Kapton former voice-coil
- Polyglass cone, Butyl surround
- High power handling
- Deep frequency in small sealed box



### Specifications

Nominal power	400 W	
Maximum power	800 W	
Sensitivity	90 dB	
Cone	Polyglass	
Surround	Butyl	
Nom. impedance	2 x 4 ohms	
DC resistance	2.1 ohms	
VC diameter	65 mm	2 <sup>9/16</sup> in
VC height	32 mm	1 <sup>1/4</sup> in
Former	Aluminium	
Layers	4	
Wire	Copper	
Inductance	2.6 mH	
Xmax	11 mm	
Magnet d x h	155 x 40 mm	6 <sup>1/8</sup> x 1 <sup>9/16</sup> in
Magnet weight	6400 g	14.1 lb
Flux density	0.75 T	
Gap height	10 mm	3/8 in
Net weight	8.4 kg	18.51 lb

### Suggested Application

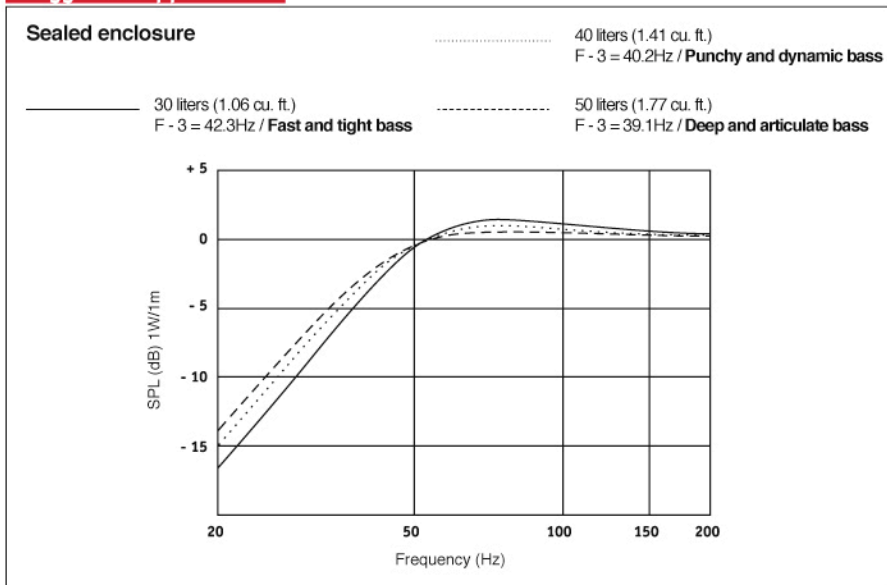

### Parameters

Fs	28.71 Hz	
Vas	76.18 l	2.69 Ft <sup>3</sup>
Qts	0.537	
Qes	0.610	
Qms	4.510	
Re	2.1 ohms	
Sd	530.93 cm <sup>2</sup>	82.29 in <sup>2</sup>
Cas	5.42E-07 m <sup>5</sup> /N	
Mas	56.66 kg/m <sup>4</sup>	
Ras	2266.19 ohms.ac	
Cms	1.92E-04 m/N	
Mms	159.71 g	0.35 lb
Rms	6.388 Kg/s	
Ces	1610.27 mF	
Les	19.08 mH	
Res	15.53 ohms	
Bl	9.96 N/A	
SPL	86.55 dB/W/m	

### Mechanical Drawing

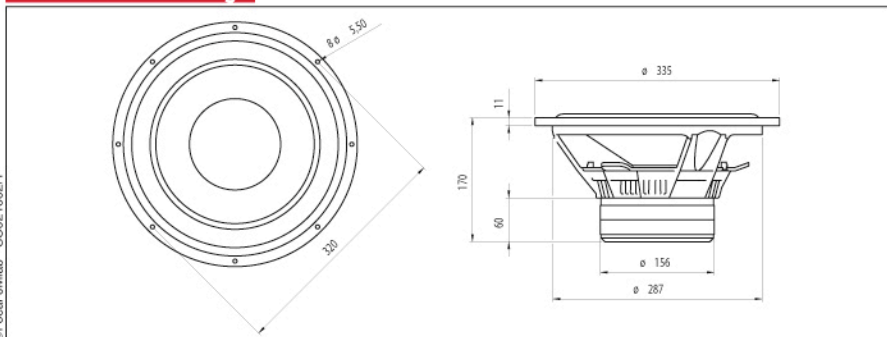

### Suggested application

Load	V (l)	Fb (Hz)	F-3 (Hz)	Ql
Vented	-	-	-	-
Sealed	-	-	-	-

Focal® is a trademark of Focal-JMLab®