

## *User Guide*

# Traveling Saw

CTS Models 5, 7 and 9

*Installation*

*Operation*

*Maintenance*

*Troubleshooting*



*Instant Access  
Parts and Service  
(800) 458-1960  
(814) 437-6861*

*[www.conairnet.com](http://www.conairnet.com)*

**CONAIR™**

The Conair Group, Inc.  
One Conair Drive  
Pittsburgh, PA 15202  
Phone: (412) 312-6000  
Fax: (412)-312-6227

UGE058/0803

*Record your equipment's model and serial number(s) and the date you received it in the spaces provided.*

It is important to record the model and serial number(s) of your equipment and the date you received it in the User Guide. Our service department uses this information, along with the manual number, to provide help for the specific equipment you installed.

Keep this User Guide and all manuals, engineering prints and parts lists together for documentation of your equipment.

<b>Date:</b>
<b>Document Number:</b> <b>UGE058/0803</b>
<b>Serial number(s):</b> ..... .....
<b>Model number(s):</b> ..... .....
<b>Power Specifications:</b>  <b>Amps</b> .....
<b>Volts</b> .....
<b>Phase</b> .....
<b>Cycle</b> .....

**DISCLAIMER:** The Conair Group, Inc., shall not be liable for errors contained in this User Guide or for incidental, consequential damages in connection with the furnishing, performance or use of this information. Conair makes no warranty of any kind with regard to this information, including, but not limited to the implied warranties of merchantability and fitness for a particular purpose.

---

# TABLE OF CONTENTS

<b>INTRODUCTION</b> . . . . .	<b>1-1</b>
Purpose of the User Guide . . . . .	1-2
How the Guide is Organized . . . . .	1-2
Your Responsibilities as a User . . . . .	1-2
ATTENTION: Read this so no one gets hurt . . . . .	1-3
How to Use the Lockout Device . . . . .	1-5
<b>DESCRIPTION</b> . . . . .	<b>2-1</b>
What is the CTS Saw? . . . . .	2-2
Typical Applications . . . . .	2-2
How the CTS Saw Works . . . . .	2-3
CTS Saw Features . . . . .	2-5
Specifications . . . . .	2-6
Optional Equipment . . . . .	2-7
<b>INSTALLATION</b> . . . . .	<b>3-1</b>
Unpacking the Boxes . . . . .	3-2
Preparing for Installation . . . . .	3-3
Positioning the CTS Saw . . . . .	3-4
Connecting the Main Power Source . . . . .	3-6
Installing the Encoder . . . . .	3-7
Installing the Saw Blades . . . . .	3-8
Preparing for Testing . . . . .	3-9
Testing the Installation . . . . .	3-9
<b>OPERATION</b> . . . . .	<b>4-1</b>
The Saw Control . . . . .	4-2
Machine Frame and Support System . . . . .	4-4
Blade Height Adjustment . . . . .	4-4
Upper Clamp Adjustment . . . . .	4-4
Power Supply . . . . .	4-5
Control Panels . . . . .	4-5
Pneumatic Cylinder Operation . . . . .	4-6
Electrical Operation . . . . .	4-7
Machine Lubrication . . . . .	4-8
System Inspection . . . . .	4-8
Blade Replacement . . . . .	4-9
Chip Collection Shrouds and Blower Connection . . . . .	4-10
<b>MAINTENANCE</b> . . . . .	<b>5-1</b>
Maintenance Features . . . . .	5-2
Warnings and Cautions . . . . .	5-2
Maintenance Overview . . . . .	5-4
Preventative Maintenance Schedule . . . . .	5-4

---

## **MAINTENANCE CONTINUED . . . . .5-1**

- Checking the Blades . . . . .5-6
- Checking Electrical Connections . . . . .5-7

## **TROUBLESHOOTING . . . . .6-1**

- Before Beginning . . . . .6-2
- A Few Words of Caution . . . . .6-2
- Identify the Cause of a Problem . . . . .6-3
- Electrical Problems . . . . .6-4
- Product Quality Problems . . . . .6-5
- Checking the Servo Amplifier . . . . .6-7
- Checking the Encoder . . . . .6-8

## **APPENDIX . . . . .**

- Customer Service Information . . . . .A-1
- Warranty Information . . . . .A-2
- Servo Instructions . . . . .B-1

## **PARTS/DIAGRAMS**

This section has been provided for you to store spare parts lists and diagrams.

---

# INTRODUCTION

- *Purpose of the User Guide . . . .1-2*
- *How the User Guide  
is organized . . . . .1-2*
- *Your Responsibilities  
as a User . . . . .1-2*
- *ATTENTION: Read this so  
no one gets hurt . . . . .1-3*
- *How to Use the  
Lockout Device . . . . .1-5*

---

## PURPOSE OF THE USER GUIDE

This User Guide describes the Conair CTS Saw and explains step-by-step how to install, operate, maintain and repair this equipment.

Before installing this product, please take a few moments to read the User Guide and review the diagrams and safety information in the instruction packet. You also should review manuals covering associated equipment in your system. This review won't take long, and it could save you valuable installation and operating time later.

---

## HOW THE USER GUIDE IS ORGANIZED

Symbols have been used to help organize the User Guide and call your attention to important information regarding safe installation and operation.



Symbols within triangles warn of conditions that could be hazardous to users or could damage equipment. Read and take precautions before proceeding.



Numbers within shaded squares indicate tasks or steps to be performed by the user.



A diamond indicates the equipment's response to an action performed by the user.



An open box marks items in a checklist.



A shaded circle marks items in a list.

---

## YOUR RESPONSIBILITY AS A USER

You must be familiar with all safety procedures concerning installation, operation and maintenance of this equipment. Responsible safety procedures include:

- Thorough review of this User Guide, paying particular attention to hazard warnings, appendices and related diagrams.
- Thorough review of the equipment itself, with careful attention to voltage sources, intended use and warning labels.
- Thorough review of instruction manuals for associated equipment.
- Step-by-step adherence to instructions outlined in this User Guide.

We design equipment with the user's safety in mind. You can avoid the potential hazards identified on this machine by following the procedures outlined below and elsewhere in the User Guide.

 **ATTENTION:**  
**READ THIS SO NO**  
**ONE GETS HURT**



**DANGER: Sharp blades!**

Most injuries caused by knife blades occur when the saw has been turned off. Handle blades with care at all times.



- Always wear cut-resistant gloves when the blade guard is open and when handling blades.
- Always lock out the saw before opening any guards.
- Always wait until the saw blade has stopped completely before opening the saw guard. (approximately five minutes)

CTS Saw are equipped with several safety devices to ensure safe operation. Never remove or disable these devices to sustain production. Operating without these devices can cause severe injury.

- The STOP button activates a circuit that stops the saw.



**WARNING: Improper installation, operation, or servicing may result in equipment damage or personal injury.**

This equipment should only be installed, adjusted, and serviced by qualified technical personnel who are familiar with the construction, operation, and potential hazards of this type of machine.

All wiring, disconnects, and fuses should be installed by qualified electrical technicians in accordance with electrical codes in your region. Always maintain a safe ground. Do not operate the equipment at power levels other than what is specified on the machine serial plate.

---

**ATTENTION:  
READ THIS SO NO  
ONE GETS HURT**



**WARNING: Voltage Hazard**

This equipment is powered by three-phase alternating current, as specified on the machine serial tag and data plate.

A properly-sized conductive ground wire from the incoming power supply must be connected to the chassis ground terminal inside the electrical enclosure. Improper grounding can result in severe personal injury and erratic machine operation.

Always disconnect and lockout power before opening the electrical enclosure or performing non-routine procedures such as maintenance.





### **WARNING: Electrical hazard**

Before performing maintenance or repairs on this product, disconnect and lock out electrical power sources to prevent injury from unexpected energization or start-up. A lockable device has been provided to isolate this product from potentially hazardous electricity.

# HOW TO USE THE LOCKOUT DEVICE

Lockout is the preferred method of isolating machines or equipment from energy sources. Your Conair product is equipped with the lockout device pictured below. To use the lockout device:

**1 Stop or turn off the equipment.**

**2 Isolate the equipment from electrical power.**

Turn the rotary disconnect switch to OFF or O position.

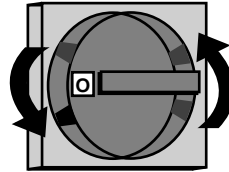

**3 Secure the device with an assigned lock or tag.**

**4 The equipment is now locked out.**

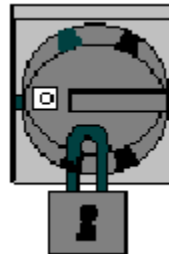

### **CAUTION: Moving parts**

Before removing lockout devices and returning switches to the ON position, make sure that all personnel are clear of the machine, tools have been removed and all safety guards are reinstalled.



---

## DESCRIPTION

- *What is the CTS Saw? . . . . .2-2*
- *Typical Applications . . . . .2-2*
- *How the CTS Saw Works . . . . .2-3*
- *CTS Saw Features . . . . .2-5*
- *Specifications . . . . .2-6*
- *Optional Equipment . . . . .2-7*

---

## WHAT IS THE CTS SAW?

The Conair CTS Saw is an on- or off-line sawing device capable of both on-demand and continuous cutting.

---

## TYPICAL APPLICATIONS

Conair CTS Saws can cut extrudable plastics and rubber both on- and off-line. Other extrudable materials-foods, ceramics, magnets, soaps, etc.-may also be cut depending on specific application requirements.

CTS Saws are available with different cutting capacities (5, 7, and 9 inches) to suit your specific needs. The standard saw orientation is right-to-left, saws can also be made with a left-to-right orientation (see Specifications in this section). (The illustrations in this User Guide represent the standard right-to-left configuration.)

CTS saws are limited to a specific range of product sizes based on each unit's cutting capacity.

Different materials, line speeds, temperatures and material cross-sections can result in different cutting torques. If you are changing any of these parameters, consult your Conair service personnel to be sure your equipment can handle the changes.

---

## HOW THE CTS SAW WORKS

The Conair CTS saws are designed for the inline cutting of profiles, pipe and tubing of a wide variety of sizes.

Located as part of the extrusion line downstream of the extruder, the CTS performs five sequential functions in the cut operation as follows:

1. The saw table begins to travel with the product in a linear motion then the clamps lock the product to the table.
2. The saw blade travels up and through the product
3. The saw blade returns to its down (home) position
4. The clamp releases the product
5. The saw table returns to its starting (home) position and readies for the next cycle

These functions are preformed automatically with contact closure by means of either depressing the manual cut pushbutton or by activating a flag switch mounted downstream of the unit as standard.

There are available options that also initiate the cut cycle including an internal timer, electronic length counter, or any other device that has a N.O. (normally open) contact.

---

# HOW THE CTS SAW WORKS

CONTINUED

The CTS Saw models have these features:

Saw clamps hold the product in place while the blades pass through it during the cutting cycle.



Extruded material enters the saw from the upstream side. (right-to-left operation)

Cut pieces are collected on a dump table or carried away on a conveyor

---

# CTS SAW FEATURES

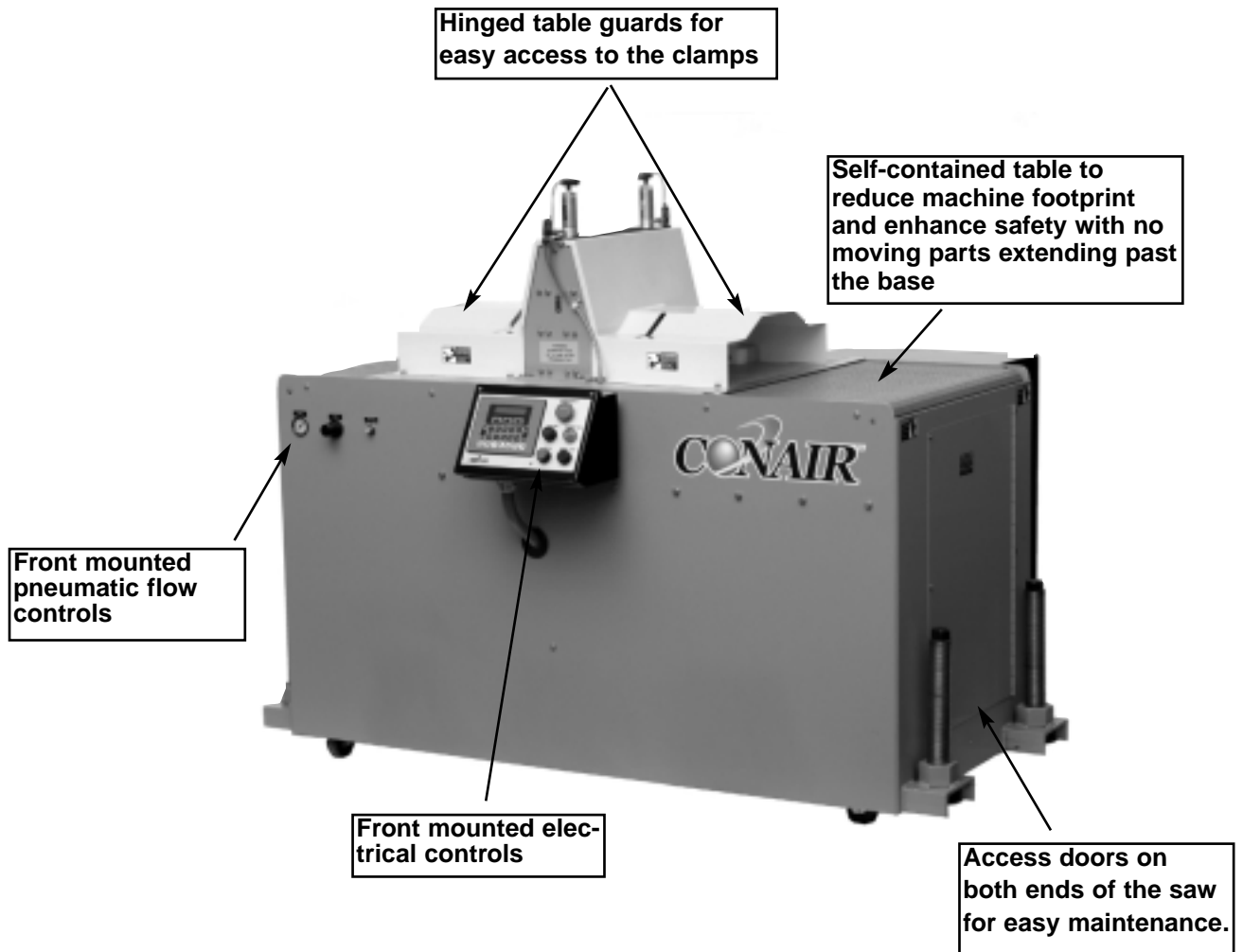

**SPECIFICATIONS**

**TRAVELING CUT-OFF SAW  
CTS Series**

**CTS-5, CTS-7 AND CTS-9**

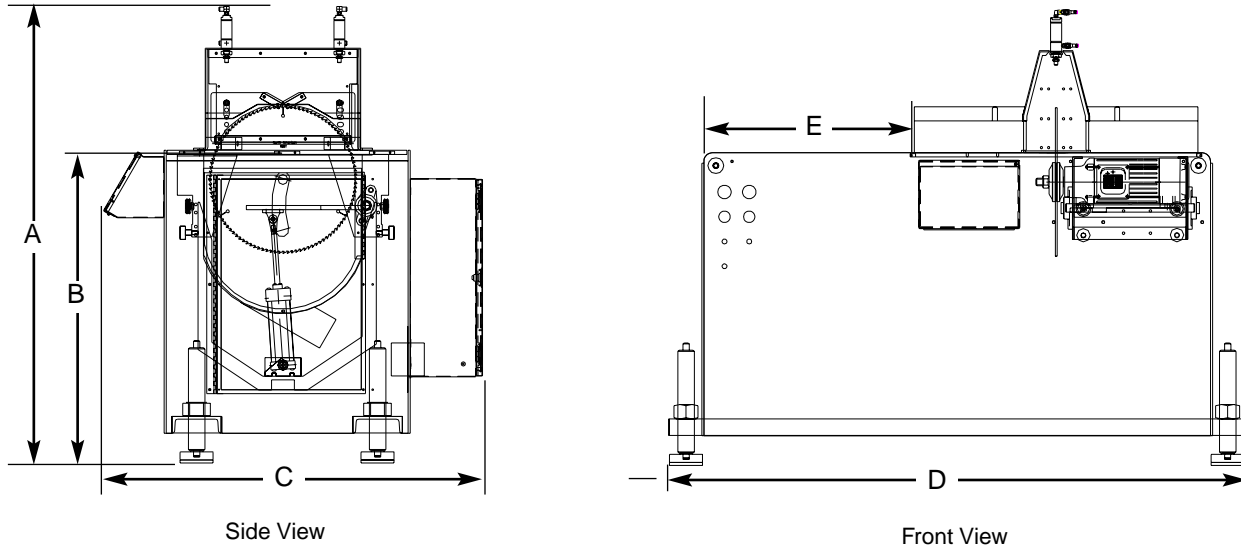

MODELS	CTS-5	CTS-7	CTS-9
<b>Performance characteristics</b>			
Pipe capacity in. {mm} OD	5 {127}	7 {178}	9 {229}
Profile capacity in. {mm} HxW*	4 x 8 {102 X 203}	5x13 {127 X 330}	6X17 {152 X 432}
Blade size in. {mm}	18 {457}	23 {584}	27 {686}
Blade type	carbide tipped	carbide tipped	carbide tipped
Blade drive motor Hp {kW}	3 {2.2}	5 {3.7}	5 {3.7}
Feed direction†	Right to left	Right to left	Right to left
<b>Dimensions in. {mm}</b>			
A - Height	57 {1448}	60 {1524}	63 {1600}
B - Height to centerline	40 {1016}	40 {1016}	40.4 {1026}
C - Width	46.5 {1181}	57 {1448}	61 {1549}
D - Length	70 {1778}	88 {2235}	88 {2235}
E - Table Travel	24 {609}	24 {609}	24 {609}
<b>Weight lbs. {kg}‡</b>			
Installed	575 {261}	825 {374}	1700 {771}
Shipping	675 {306}	925 {420}	1800 {817}
<b>Voltage Total Amps§</b>			
230V/3 phase/60 Hz	9.7 A	15.1 A	15.1 A
460V/3 phase/60 Hz	4.9 A	7.6 A	7.6 A
230V/3 phase/60 Hz (servo)	26.2 A	30.6 A	30.6 A
460V/3 phase/60 Hz (servo)	13.1 A	15.3 A	15.3 A
<b>Compressed air requirement</b>			
Pressure psi {bars}	80 {5.52}	80 {5.52}	80 {5.52}
Consumption ft³/m {liter/sec}	5 {2.4}	7 {3.3}	8 {3.8}
NPT fitting size	3/8 in.	3/8 in.	3/8 in.
<b>SPECIFICATION NOTES:</b>			
* The HxW dimension is provided for guidance only. The actual capacity can vary depending on the profile you are trying to produce.			
† Left to right feed direction is available as an option.			
‡ If the optional chip collection system is ordered, add 50 lbs. {22.7 kg} to the installed and shipping weights.			
§ The optional chip collection system adds 6 A on 230V models; 3 A on 460V models.			



---

**Flag switch for cut length activation**

**Programmable length counter for cut length activation**

**Servo control for optimal cut length and repeatable length accuracy**

**Dust collector system for material particulates retention (highly recommended for proper operation)**

**Left to right machine operation**

This options changes the machine direction from the standard right to left extrusion flow.

**Finer tooth blade for thin material and materials that are easy to fracture.**

## **OPTIONAL EQUIPMENT**

---

---

---

## INSTALLATION

- *Unpacking the Boxes* . . . . .3-2
- *Preparing for Installation* . . . . .3-3
- *Positioning the CTS Saw* . . . . .3-4
- *Connecting the Main  
Power Source* . . . . .3-6
- *Installing the Encoder* . . . . .3-7
- *Installing the Saw  
Blades* . . . . .3-8
- *Preparing for Testing* . . . . .3-9
- *Testing the Installation* . . . . .3-9

---

# UNPACKING THE BOXES

The CTS Saw comes fully assembled in a single crate.



## **CAUTION: Lifting**

To avoid personal injury or damage to the saw lift the saw using a forklift or hoist with straps that have been positioned at the saw's center of gravity.



- 1** Carefully uncrate the saw and its components.
- 2** Remove all packing material, protective paper, tape, and plastic. Compare contents to the shipping papers to ensure that you have all the parts.
- 3** Carefully inspect all components to make sure no damage occurred during shipping. Check all wire terminal connections, bolts, and any other electrical connections, which may have come loose during shipping.
- 4** Record serial numbers and specifications in the blanks provided on the back of the User Guide's title page. This information will be helpful if you ever need service or parts.
- 5** You are now ready to begin installation. Complete the preparation steps on page 3-3.

# PREPARING FOR INSTALLATION

## 1 You need these tools for installation:

- wire strain relief
- 16- or 18-inch adjustable wrench
- set of Allen wrenches
- ½ inch open or box end wrench
- flashlight

## 2 Plan the location. Make sure the area where the saw is installed has the following:

- **A grounded power source.** Check the saw's serial tag for the correct amps, voltage, phase and cycles. All wiring should be completed by qualified personnel and should comply with your region's electrical codes.
- **Clearance for safe operation and maintenance.** Make sure there is enough clearance around the saw for maintenance and servicing.



### **WARNING: Improper installation, operation, or servicing may result in equipment damage or personal injury.**

This equipment should only be installed, adjusted, and serviced by qualified technical personnel who are familiar with the construction, operation, and potential hazards of this type of machine.

All wiring, disconnects, and fuses should be installed by qualified electrical technicians in accordance with electrical codes in your region. Always maintain a safe ground. Do not operate the equipment at power levels other than what is specified on the machine serial tag and data plate.

---

# POSITIONING THE CTS SAW

- 1 Move the saw into position.** Place the saw in position downstream of the belt puller.



## CAUTION: Lifting

To avoid personal injury or damage to the saw, lift the saw using a forklift or hoist with straps that have been positioned at the saw's center of gravity.

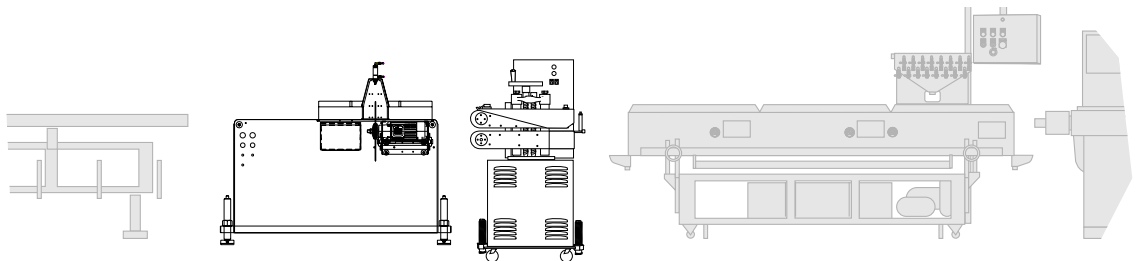

Saw

- 2 Determine the best distance** from the belt puller to the CTS Saw.

- **For flexible products**, the saw should be as close as possible to the puller.
- **For rigid products**, leave enough space to allow the product to flex during the cutting cycle. In some cases, it may be necessary to allow 6-8 feet between the puller and saw.

- 3 Align the saw with the extrusion line.**

- 4 Measure the centerline height** of the extrudate as it exits the extrusion die. Adjust all equipment on the extrusion line (sizing tank, cooling tanks, belt puller, and saw) to this height.

continued on the next page

---

## POSITION THE SAW CONTINUED

- 5** Adjust the saw's floorlock/caster assembly to the center height of the extrusion line using a 16- or 18-inch adjustable wrench. Once the correct height is reached, adjust the pad assembly to remove the weight from the casters for operation. This minimizes machine vibration during the cutting cycle.

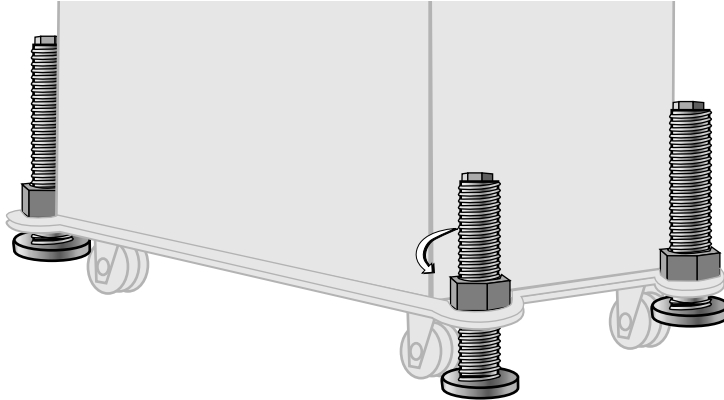

- 6** Use a plumb line or laser to check for a **straight line** from the extrusion die through each line component to the saw center line of the table. Adjust as necessary.

# CONNECTING THE MAIN POWER SOURCE



## **WARNING: Electrical hazard**

Before performing any work on this product, disconnect and lock out electrical power sources to prevent injury from unexpected energization or start-up. A lockable device has been provided to isolate this product from potentially hazardous electricity.



## **WARNING: Improper installation, operation, or servicing may result in equipment damage or personal injury.**

This equipment should only be installed, adjusted, and serviced by qualified technical personnel who are familiar with the construction, operation, and potential hazards of this type of machine.

All wiring, disconnects, and fuses should be installed by qualified electrical technicians in accordance with electrical codes in your region. Always maintain a safe ground. Do not operate the equipment at power levels other than what is specified on the machine serial tag and data plate.

**IMPORTANT:** Always refer to the wiring diagrams that came with your saw before making electrical connections. The diagrams show the minimum size main power cable required for your saw, and the most accurate electrical component information.

- 1 Open the servo saw's electrical enclosure.** Turn the disconnect dial on the door to the OFF or O position and open the door.

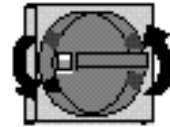

- 2 Insert the main power wire** through the knockout in the side of the enclosure. Secure the wire with a rubber compression fitting or strain relief.

- 3 Connect the power wires** to the terminals indicated on the wiring diagram that came with your machine.

- 4 Check every terminal screw** to make sure wires are secure. Gently tug each wire. If a wire is loose, use a screwdriver to tighten the terminal.

- 5 Connect the ground wire** to either grounding point shown in the diagram.

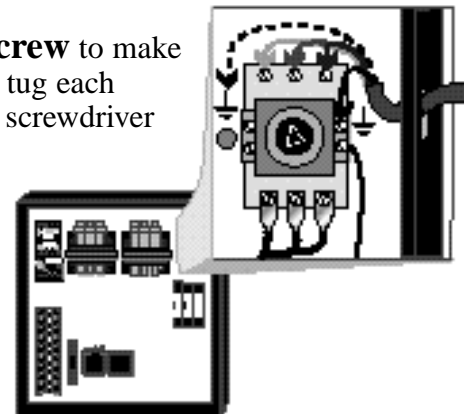





### **CAUTION: Handle with care.**

The encoder is a delicate piece of equipment and must be handled gently.

## **INSTALLING THE ENCODER**

Conair uses bi-directional encoders to ensure that only product that moves forward is counted.

Installing the encoder consists of several parts:

- the encoder
- the measuring wheel
- the connecting cable

The encoder is fitted with a 1 foot circumference wheel which rides on either the upper belt of the belt puller or (for rigid profiles and pipe) on the extrudate itself upstream of the puller.



**Encoder**



**Wheels**



**Connecting Cable**

The encoder is supplied with an integral mounting bracket. How and where you attach the encoder to the puller depends on your particular puller and application.

- If the wheel rides on the puller belt, make sure that its linear alignment is the same as the belt. Place the wheel near the center of the belt to minimize bouncing. Try to avoid cracks and other belt features that may affect accuracy.
- Make sure the location allows you to keep the wheel clean. Any small buildup on the wheel will affect its circumference and change the cut length.

After the encoder is installed, attach it to the saw control using the supplied cable. The cable has been hard-wired to the control at the factory.

# INSTALLING THE SAW BLADES



## **DANGER: Sharp blades!**

Most injuries caused by saw blades occur when the saw has been turned off. Handle blades with care at all times.



- Always wear cut-resistant gloves when the blade guard is open and when handling blades.
- Always lock out power to the saw before opening any guards.
- Always wait until the saw blade has completely stopped before opening the saw guard. (approximately five minutes)

CTS saws are equipped with several safety devices to ensure safe operation. Never remove or disable these devices to sustain production. Operating without these devices can cause severe injury.

**1** Open the rear access door of the machine.

**2** Remove the screws that retain the blade door to the blade shroud and hinge open the door.

**IMPORTANT:** Always note the blade tooth direction when removing blade to insure that the replacement blade is installed the same. Rotating a carbide blade in the wrong direction will usually damage the blade. As standard, the blade rotation should have the top of the blade rotating away from the front or operator side of the unit.

**3** Remove the hex nut.

The blade is held on with a hex nut tightened on the motor arbor shaft. Based on either right to left or left to right saw operation, the hex nut will be either a left hand or right hand thread. A right to left saw operation means that the product is entering the saw from the right side. A right to left operating saw will use a left-handed threaded arbor. This is done to insure that the arbor nut will want to continually tighten during blade rotation. The motor has an arrow on the housing to indicate the arbor rotation. Remove the hex nut using the spanner wrench provided to hold the blade shaft. The saw blades will be removable at this time.

---

## PREPARING FOR TESTING

- 1 Make sure all components** are installed according to assembly drawings. Make sure that all bolts on the saw have been tightened.
- 2 Check that saw is firmly locked** into position with the anchoring screws.
- 3 Check that all wiring conforms to electrical codes**, and all wiring covers are in place.
- 4 Plug in the air supply**

---

## TESTING THE INSTALLATION

- 1 Turn on the main disconnect.** Plug in the main power cord and turn on the main disconnect.
- 2 Check that the E-Stop button is in the out, extended position.**
- 3 Press the vacuum start button.**  
Check the rotation of the vacuum motor for correct phasing. (The phase in your plant may be different from the Conair factory.)
- 4 Press the saw start button.**  
Turn off the saw and vacuum.
- 5 Check the saw blade rotation.**  
The top of the saw blade should turn towards the front or operator side. If the top of the blade is spinning away from you or the operator side switch one of the 3-phase plug wires. Then recheck the blade rotation.
- 6 Make a sample cut.** Restart the vacuum and the saw motor and press the manual cut button. The saw should make one sample cut.

If the saw is not working properly at any time, turn it off immediately and refer to the Troubleshooting section of this User Guide.

If you do not encounter any problems, proceed to the Operation section.

---

---

---

# OPERATION

- *The Saw Control* . . . . .4-2
- *Machine Frame and Support System* . . . . .4-4
- *Blade Height Adjustment* . . . . .4-4
- *Upper Clamp Adjustment* . . . . .4-5
- *Power Supply* . . . . .4-5
- *Control Panels* . . . . .4-5
- *Pneumatic Cylinder Operation* . . . . .4-6
- *Electrical Operation* . . . . .4-7
- *Machine Lubrication* . . . . .4-8
- *System Inspection* . . . . .4-8
- *Blade Replacement* . . . . .4-9
- *Chip Collection Shrouds and Blower Connection* . . . .4-10

---

# THE SAW CONTROL

**IMPORTANT:** Before applying power, ensure that the SAW BLADE UP and TABLE FORWARD valves are closed (fully clockwise), and that the saw blade is not installed on the cut-off saw.

- 1** Connect the electrical line cord to a source of power compatible with the nameplate on the saw cut-off saw.
- 2** Connect the air supply to the FRL (filter-regulator-lubricator) on the saw.
- 3** If the optional dust collector was purchased, **install and connect the dust collector**
- 4** Turn the main disconnect switch to the ON position; the POWER ON light will illuminate.
- 5** Press Start or (if equipped with Dust Collector) turn Dust Collector power “ON” first and then press saw motor “START”
- 6** Check the motor rotation. If the motor rotation is incorrect: Reverse the connections at the AC plug end.
- 7** Once the rotation is correct, disconnect the power, and install the blade on the cut-off saw.
- 8** Make sure that the FRL is set for 6--65 PSI

**NOTE:** Setting the FRL to higher level will only release air from the system. The CTS is equipped with a relief valve that is preset for approximately 70 PSI. The CTS is equipped with a relief valve that is preset for approximately 70 PSI. The relief valve is in place to protect the air components from damage due to excessive air pressure.

- 9** Press MANUAL CUT
- 10** Adjust the TABLE FORWARD speed control to match the approximate line speed.
- 11** Adjust the SAW BLADE UP speed control to the desired blade travel speed.
- 12** Set the blade height limit by adjusting the collar on the lifting rod (located on the table surface)

continued on the next page

- 
- 13** Adjust the **TABLE RETURN** speed control to the suitable travel return speed.

**NOTE:** *The TABLE RETURN pressure must be set high enough to return the table to the start position and trigger the TABLE START micro-switch.*

- 14** Adjust the **clamp pressure regulator** to grasp the profile firmly.

**NOTE:** *Both the clamp pads and pressure can be adjusted so that the profile is not crushed.*

## THE CONTROL FEATURES CONTINUED

---

## **MACHINE FRAME AND SUPPORT SYSTEM**

The machine frame is constructed of welded steel that has been primed and painted to resist corrosion and provide a maintenance free finish. The frame is supported by, four leveling screws, that both permanently fix the position of the unit and also help accommodate any uneven flooring. These screws have a welded hex nut to allow adjustment with a wrench.

The motors and machine components are mounted inside the frame and completely guarded for operator safety.

These and all guards should always remain securely in place when machine is running and should be re-installed after any maintenance procedures that have required their removal.

---

## **BLADE HEIGHT ADJUSTMENT**

The saw blades are mounted to and driven by a 3500 RPM arbor motor. This motor is mounted on a pivot assembly, which guides and secures the saw blade through the cutting process.

There is adjustment for how high the saw blade will extend through the table depending on the product being cut. For maximum cut cycles, the saw blade should be adjusted so that the blade just passes through the product before returning home. Too much blade extension will waste valuable time and limit the amount of cuts that will be available per minute. This adjustment is made externally with the hand knob positioned at the rear of the cutting table. Turning the knob counterclockwise will allow the blade to extend farther up through the table and turning the knob clockwise will reduce the amount that the blade will come up.



---

## UPPER CLAMP ADJUSTMENT

As with the blade height adjustment, there is also a requirement to adjust the product clamps to adequately clamp different size products. The clamps are reversible and can be used for clamping round or flat items. If you are running a round product such as pipe or tubing, the side of the clamp that has a "V" notch should be used and for flat surfaced products, the straight side of the clamp should be used.

**To remove and/or adjust each clamp assembly:**

- 1** Lock out and tag out the power to the saw. *See Section 1: Introduction, How to use the Lockout Device.*
- 2** Wait at least five minutes for the blade to stop completely.
- 3** Pull the hitch pin from the clamp keeper pin and remove both pins.
- 4** Slide the clamps to the desired position.
- 5** Re-insert the keeper pins.
- 6** Re-install the hitch pins.

**IMPORTANT:** *The clamps should be set approximately 1/8"-1/4" above the product in the "up" position to allow for positive clamping. Always check to see if setting is correct before operating in line.*

---

This equipment is powered by either 230 or 460 VAC , Three Phase, as specified on the machine nameplate.

## POWER SUPPLY

- 1** Connect the machine power through a fused disconnect of proper rating. Make sure the power is grounded through the power cable to the plant electrical ground.

---

The operator control panels are located on the front of the saw frame. The pneumatic control panel is located to the left of the operator controls platform. It consists of a pressure regulator, pressure gauge, and flow controls. All items are labeled, easily accessible and lockable.

## CONTROL PANELS

The electrical control panel is located just to the right of the pneumatic control. It consists of start and stop pushbuttons, a power on light, a manual cut pushbutton and an emergency stop extended pushbutton. All items are labeled and easily accessible.

---

# PNEUMATIC CYLINDER OPERATION

The carriage travel, blade pivot and clamp assemblies are moved with air cylinders. The speed of the movement of the **carriage assembly** is controlled by flow controls located on the operator panel. Clockwise rotation will slow the table speed and counterclockwise rotation will increase the table speed.

The **blade pivot assembly** is moved up and down with an air cylinder located below the table. It is controlled by flow controls mounted on the operator panel. These are labeled table up speed and table down speed. Clockwise rotation will slow the table movement speed and counterclockwise rotation will increase the table movement speed.

The **clamp assembly** is moved up and down by air cylinders mounted above the clamp. They are controlled by flow controls mounted on the Cylinders. Clockwise rotation will slow the clamp movement speed and counterclockwise rotation will increase the clamp movement speed.

The table and clamp pressure setting is adjusted with a pressure regulator located on the operator panel. The pressure level setting is displayed on the gauge located above the regulator. The table and clamp pressure should never exceed 60 PSI.

The main filter/regulator/lubricator is mounted on the side of the machine near the electrical enclosure and should be maintained as described in the manufacturers documentation.

This unit should always be supplied with clean dry air. Incoming pressure should be set at approximately 65 PSI. Maximum pressure is 70 PSI.

***IMPORTANT:*** *This unit should always be supplied with clean dry air. Incoming pressure should be set at approximately 65 PSI. Maximum pressure is 70 PSI.*

---

The operation of the saw consists of an automatic sequence of events.

- 1** To start the saw the main power must be on and the appropriate air supply to the machine. With the power on, the control panel will have the power on light illuminated.
  
- 2** To start the saw motor, push the start button. Once the saw motor is started, push the yellow manual cut button and the machine will start its automatic cycle. The clamps will come down and the table will begin to travel away from its home position. Immediately after this happens, the saw pivot assembly will raise the blade up through the table slot until it reaches its up limit switch. Upon reaching this switch, the saw pivot will immediately return down through the table, the clamps will raise and the table will return to its home position, completing one cycle.

## ELECTRICAL OPERATION

**IMPORTANT:** *An important reminder is that the speed settings of the pneumatic flow controls will affect the cycle time of the machine. The flow controls must be set properly to a compromise between cycle time and cut quality. Flow control settings should be adjusted at this time and fine-tuned during the initial phase of the saw operation.*

---

## MACHINE LUBRICATION

The machine is supplied to you completely lubricated. After running the unit for long periods of time, this lubrication will break down and become useless. Follow this lubrication chart for optimum performance.

Component	Type of Lubricant	Duration
Table Pivot Bearings	Chassis Lube	6-9 months
Clamp Post Slides	Chassis Lube	5-6 months

---

## SYSTEM INSPECTION

Although this unit was designed to require a minimum amount of maintenance, it should be inspected periodically to insure that it remains in top operating condition.

Items to inspect are as follows:

- Saw Tracks- The steel tracks that the saw motor carriages travel on, will after time, begin to wear from the constant contact with the cam rollers. They should be visually inspected for wear and replaced as necessary.

- Saw Track Rollers- The steel cam rollers that the saw motor carriages travel on, will after time, begin to wear from the constant contact with the saw tracks. They should be visually inspected for wear and replaced as necessary.

- Pneumatic System- Approximately once every 12 months or sooner if able, all system pneumatic components should be visually inspected. All hoses should be checked for wear or damage. All regulators and flow controls should be adjusted through their usable ranges to insure proper operation.

- 1 Lock out and tag out the power to the saw.** See Section 1: Introduction, How to use the Lockout Device.
- 2 Wait at least five minutes for the blade to stop completely.**

**IMPORTANT:** Always note the blade tooth direction when removing blade to **insure that the replacement blade is installed the same.** Rotating a carbide blade in the wrong direction will usually damage the blade. As standard, the blade rotation should have the top of the blade rotating away from the front or operator side of the unit.

- 3 Open the rear access door of the machine.**
- 4 Remove the screws that retain the blade door to the blade shroud and hinge open the door.**
- 5 Remove the hex nut.**

The blade is held on with a hex nut tightened on the motor arbor shaft. Based on either right to left or left to right saw operation, the hex nut will be either a left hand or right hand thread. A right to left saw operation means that the product is entering the saw from the right side. A right to left operating saw will use a left-handed threaded arbor. This is done to insure that the arbor nut will want to continually tighten during blade rotation. The motor has an arrow on the housing to indicate the arbor rotation. Remove the hex nut using the spanner wrench provided to hold the blade shaft. The saw blades will be removable at this time.

## BLADE REPLACEMENT



### **WARNING:** Electrical hazard

Before performing maintenance or repairs on this product, disconnect and lock out electrical power sources to prevent injury from unexpected energization or start-up. A lockable device has been provided to isolate this product from potentially hazardous electricity.



### **CAUTION:** Moving parts

Before removing lockout devices and returning switches to the ON position, make sure that all personnel are clear of the machine, tools have been removed and all safety guards are reinstalled.

---

# CHIP COLLECTION SHROUDS AND BLOWER CONNECTION

The CTS Saw has been equipped with a chip collection shroud that is connected to the outside of the base to aid in removing chips and debris from the blade area.

The success rate of chip removal is dependent on the type and ability of the customer supplied removal system or Conair's optional vacuum system.

***WARNING: If you did not purchase a Conair dust collection system **you must** connect a customer supplied dust collector. Failure to do so may result in a fire hazard!***

---

# MAINTENANCE

- *Maintenance Features* . . . . .5-2
- *Warnings and Cautions* . . . . .5-2
- *Maintenance Overview* . . . . .5-4
- *Preventative Maintenance*
  - Schedule* . . . . .5-4
- *Checking the Blades* . . . . .5-6
- *Checking Electrical*
  - Connections* . . . . .5-7

---

## MAINTENANCE FEATURES

The CTS Saw models need regular, scheduled maintenance for peak performance. Among the features that require maintenance are:

- Saw blades
- Blade mounting hardware
- Product guides
- The saw guard hardware
- Saw alignment
- Floor locks
- Shafts of optional slide rail system
- Electrical cables
- Control panel lights

---

## WARNINGS AND CAUTIONS

To maintain the best performance of the saw it must be cleaned and inspected regularly. Maintenance includes a daily, weekly, quarterly, and semi-annual (every 6 months) schedule.

Use this maintenance schedule as a guide. You may need to shorten the time of the maintenance schedule, depending on how often you use the saw, and the types of material flowing through it.

Follow all precautions and warnings when working on the equipment.



**WARNING: Improper installation, operation, or servicing may result in equipment damage or personal injury.**

This equipment should only be installed, adjusted, and serviced by qualified technical personnel who are familiar with the construction, operation, and potential hazards of this type of machine.

All wiring, disconnects, and fuses should be installed by qualified electrical technicians in accordance with electrical codes in your region.





### **WARNING: Voltage Hazard**

This equipment is powered by alternating current, as specified on the machine serial tag and data plate. Do not operate the equipment at power levels other than what is specified on the machine serial tag and data plate.

A properly-sized conductive ground wire from the incoming power supply must be connected to the chassis ground terminal inside the electrical enclosure. Improper grounding can result in severe personal injury and erratic machine operation.

Before performing maintenance or repairs on this product, disconnect and lock out electrical power sources to prevent injury from unexpected energization or start-up. A lockable device has been provided to isolate this product from potentially hazardous electricity.

## **WARNINGS AND CAUTIONS CONTINUED**



### **DANGER: Sharp blades!**

Most injuries caused by saw blades occur when the saw has been turned off. Handle blades with care at all times.



- Always wear cut-resistant gloves when the blade guard is open and when handling blades.
- Always lock out power to the saw before opening any guards.
- Always wait until the saw blade has completely stopped before opening the saw guards. (approximately five minutes.)

CTS saws are equipped with several safety devices to ensure safe operation. Never remove or disable these devices to sustain production. Operating without these devices can cause severe injury.

---

# MAINTENANCE OVERVIEW

This section describes the daily, weekly, monthly and semi-annual maintenance schedules that should be performed when changing materials or lines, or when changing equipment, as well as the maintenance procedures to follow.

Cutting either flexible or rigid materials generates tremendous shock and vibration to the entire unit. Anything that can loosen, will over time.

To maintain the best performance, follow this maintenance schedule and develop an effective preventative maintenance program.

---

# PREVENTATIVE MAINTENANCE SCHEDULE

## ● Daily

### ☐ Checking saw blade(s)

Clean, sharpen or replace as needed (see Section 4, Blade Replacement.)

### ☐ Inspecting the blade mounting hardware

The blade securing bolt should use both a lock washer and flat washer, and be tightened enough to fully compress the lock washer. Replace the holding pins if they appear worn.

### ☐ Inspecting the the saw product guides for wear and alignment.

### ☐ Inspecting saw alignment

Proper saw alignment is critical for optimum performance. Use a plumb line or laser to check for a straight line from the extrusion die to the saw bushings.

### ☐ Check floor locks

It is always recommended that the weight be removed from the casters for optimum stability during cutting cycles. Check to see if the floor locking mechanism is properly adjusted.

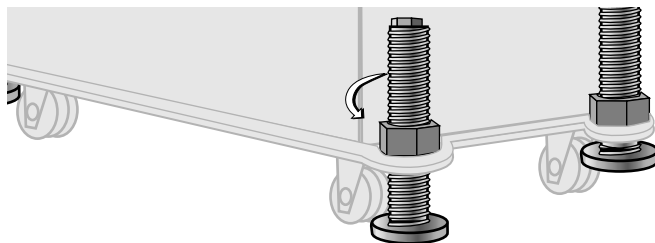

# PREVENTATIVE MAINTENANCE SCHEDULE

## CONTINUED

### ● Weekly

- Blow or vacuum, dust and chips from all surfaces of the saw. Open pneumatic and electrical enclosures and remove the dust and chips from all components.
- Check that the FRL (filter-regulator-lubricator) for the air input is filled with oil and that the oiler is working. Pressure should be set for around 60 PSI.

This unit also has an automatic drain for any moisture that may develop. The bowl should be kept clean to ensure it will operate properly.

### ● Quarterly

- Blow or vacuum, dust and chips from the inside the saw. Remove all dust and chips from inside all control cabinets. Remove any excess oil from the pneumatic enclosure.
- Verify that all electrical terminals are tight.
- Check that all air lines are in order (free of cuts or abrasions). Check the saw travel rails and rollers for debris and wear.
- Check that the adjustable mufflers on the SAW BLADE UP cylinder is set for a smooth downward return.
- Check that the adjustable mufflers on the clamp cylinder are set so that the clamp operates quickly - a slow cycle on the clamp-down will cause inaccurate cuts in length.
- Check the condition of the clamp pads. If worn or damages, replace with a new set of pads.
- Check the condition of the clamp pads. If worn or damages, replace with a new set of pads.
- Check the condition of the blade. If the blade is dull, have the unit sharpened; if it is damaged, have the blade replaced.



#### **WARNING:** Electrical hazard

Before performing maintenance or repairs on this product, disconnect and lock out electrical power sources to prevent injury from unexpected energization or start-up. A lockable device has been provided to isolate this product from potentially hazardous electricity.



#### **CAUTION: Moving parts**

Before removing lock-out devices and returning switches to the ON position, make sure that all personnel are clear of the machine, tools have been removed and all safety guards are reinstalled.

---

# CHECKING BLADES

Blades become dull over time depending on the material being cut, cut rate, blade speed, and blade material and thickness. Check blades regularly for sharpness as well as scratches, nicks, burrs, and material buildup. Clean, sharpen or replace as needed (see Installing Saw Blades).



## **DANGER: Sharp blades!**

Most injuries caused by knife blades occur when the saw has been turned off. Handle blades with care at all times.



- Always wear cut-resistant gloves when the blade guard is open and when handling blades.
- Always lock out the saw before opening any guards.
- Always wait until the saw blade has stopped completely before opening the saw guard. (approximately five minutes)

CTS Saw are equipped with several safety devices to ensure safe operation. Never remove or disable these devices to sustain production. Operating without these devices can cause severe injury.

- The STOP button activates a circuit that stops the saw.



## **WARNING: Improper installation, operation, or servicing may result in equipment damage or personal injury.**

This equipment should only be installed, adjusted, and serviced by qualified technical personnel who are familiar with the construction, operation, and potential hazards of this type of machine.

All wiring, disconnects, and fuses should be installed by qualified electrical technicians in accordance with electrical codes in your region. Always maintain a safe ground. Do not operate the equipment at power levels other than what is specified on the machine serial plate.

# CHECKING ELECTRICAL CONNECTIONS



## **WARNING: Electrical hazard**

Before performing any work on this product, disconnect and lock out electrical power sources to prevent injury from unexpected energization or start-up. A lockable device has been provided to isolate this product from potentially hazardous electricity.



## **WARNING: Improper installation, operation, or servicing may result in equipment damage or personal injury.**

This equipment should only be installed, adjusted, and serviced by qualified technical personnel who are familiar with the construction, operation, and potential hazards of this type of machine.

All wiring, disconnects, and fuses should be installed by qualified electrical technicians in accordance with electrical codes in your region. Always maintain a safe ground. Do not operate the equipment at power levels other than what is specified on the machine serial tag and data plate.

- 1 Be sure the main power is disconnected and the saw is locked out.** Always disconnect and lock out the main power source before opening the unit or servicing.
- 2 Turn the main power disconnect to the off position** before opening the electrical enclosure on the back of the saw or the back of the control. This is a safety device to prevent you from opening the doors if the power is still on.



continued on the next page

---

# CHECKING ELECTRICAL CONNECTIONS CONTINUED

- 3** Open the electrical enclosure.
- 4** **Inspect all wires and connections.** Look for loose wires, burned contacts, and signs of over-heated wires. Have a qualified electrician make any necessary repairs or replacements.
- 5** Close the electrical enclosure door.
- 6** **Inspect the exterior power cords.** Cords should not be crimped, exposed, or rubbing against the frame. If the main power cord runs along the floor, make sure it is not positioned where it could rest in pooling water or could be run over and cut by wheels or casters.

---

# TROUBLESHOOTING

- *Before Beginning* . . . . .6-2
- *A Few Words of Caution* . . . . .6-2
- *Identifying the Cause of a Problem* . . . . .6-3
- *Electrical Problems* . . . . .6-4
- *Product Quality Problems* . . . . .6-5
- *Checking the Servo Amplifiers* .6-7
- *Checking the Encoder* . . . . .6-8

---

## BEFORE BEGINNING

You can avoid most problems by following the recommended installation, operation and maintenance procedures outlined in this User Guide. If you have a problem, this section will help you determine the cause and tell you how to fix it.

Find any wiring, parts, and assembly diagrams that were shipped with your equipment. These are the best reference for correcting a problem. The diagrams will note any custom features or options not covered in this User Guide.

Verify that you have all instructional materials related to the saw. Additional details about troubleshooting and repairing specific components are found in these materials.

Check that you have manual for other equipment connected in the system. Troubleshooting may require investigating other equipment attached to, or connected with the saw.

---

## A FEW WORDS OF CAUTION



**WARNING: Improper installation, operation, or servicing may result in equipment damage or personal injury.**

This equipment should only be installed, adjusted, and serviced by qualified technical personnel who are familiar with the construction, operation, and potential hazards of this type of machine.

All wiring, disconnects, and fuses should be installed and adjusted by qualified electrical technicians in accordance with electrical codes in your region. Always maintain a safe ground. Do not operate the equipment at power levels other than what is specified on the machine serial tag and data plate.



**WARNING: Electrical hazard**

Before performing maintenance or repairs on this product, disconnect and lock out electrical power sources to prevent injury from unexpected energization or start-up. A lockable device has been provided to isolate this product from potentially hazardous electricity.





### **DANGER: Sharp blades!**

Most injuries caused by saw blades occur when the saw has been turned off. Handle blades with care at all times.



- Always wear cut-resistant gloves when the cutting chamber is open and when handling blades.
- Always lock out power to the saw before opening the cutting chamber.
- Always wait until the saw has completely stopped before opening the cabinet door.

CTS saws are equipped with several safety devices to ensure safe operation. Never remove or disable these devices to sustain production. Operating without these devices can cause severe injury.

The Troubleshooting section covers problems directly related to the operation and maintenance of the saw. This section does not provide solutions to problems that originate with other equipment. Additional troubleshooting help can be found in manuals supplied with the other equipment.

The main problems you will see with the saw are:

- **Saw operation problems**, which focus on problems that are clearly related to the operation of the saw's electrical control systems.
- **Plastic product quality concerns**, which deal with product characteristics that may be related to saw operation. Of course, other sections of the extrusion line also influence the quality of the extruded product. This section does not provide solutions to problems originating with other equipment on the extrusion line.

Additional troubleshooting help can be found in the manufacturer's manuals included with this User Guide.

## **IDENTIFYING THE CAUSE OF A PROBLEM**

# ELECTRICAL PROBLEMS

Look in this section when you have problems such as lights on the control that are working improperly, buttons that do not execute the function properly, and when information input is not executed properly.

Symptom	Possible cause	Solution
◆ Saw will not start	The E-stop button is depressed.	Make sure the E-stop is extended.
	Motor overload tripped	Reset motor overload.
	Disconnect in the off position.	Turn disconnect to the on position.
◆ Saw blade runs backwards	AC Power is phased incorrectly for your plant	Change the wire on the plug to match your plants AC phasing.

# PRODUCT QUALITY PROBLEMS

Symptom	Possible cause	Solution
◆ Cut not square	Product guides not aligned square to the blade face	Re-align the product guides. Insure that the rear guide is square with the saw blade and tighten. Adjust the front guide accordingly allowing enough clearance for smooth product passage.
◆ Crack or fractures in cut surfaces	Blade speed too fast	Adjust speed control for blade feed into part (slower)
	Incorrect blade design	Investigate blade choice for the application.
	Incorrect cooling of extrudate	Improve the molecular structure with variation of cooling time or temperature.
◆ General poor cut quality	Incorrect blade design	Investigate blade choice for the application.
	Blade running backwards	Check motor rotation Check blade installation
◆ Product melting at cut	Blade speed too slow	Adjust speed control for blade feed into part (faster)
	Incorrect blade design	Investigate blade choice for the application.

# PRODUCT QUALITY PROBLEMS

CONTINUED

Symptom	Possible cause	Solution
◆ Incorrect cut length	Encoder or input device problem	Check encode or input device
	Puller problem	Check puller for drive consistencies or any belt to product slippage.
	Counter problem	Check cut length counter
	Saw clamps not holding	Check rubber saw clamps for wear and replace as necessary
◆ Table motion inconsistent	Roller ways dirty	Clean roller ways
	Rodless cylinder problem	Check and clean rodless cylinder
	Solenoid problem	Check table actuation solenoid for proper operation
	Low air pressure	Check main system regulator for incoming air pressure settings

---

The servo amplifier is equipped with a digital readout that can be seen through the viewing window on the electrical enclosure. This display shows amplifier status and error messages. Refer to the supplier's documentation included with this User Guide.

## CHECKING THE SERVO AMPLIFIER

***NOTE:*** Make sure you look for servo amplifier messages before you shut off the power.

---

## CHECKING THE ENCODER

When the encoder is working properly, the encoder LEDs on the control panel light or flicker as the encoder wheel moves and generates signals. If the LEDs do not light when the encoder wheel moves:

- 1 Check all connections.**
- 2 Check the encoder cable for damage.** If necessary, replace.
- 3 Check the connector that attaches the cable to the encoder.** Internal wiring may be shorted out if this connector is not handled properly.
- 4 Check the encoder itself.** There should be no play in the shaft.



### **WARNING: Delicate equipment**

The encoder is a delicate piece of equipment. Any rough handling can damage fragile parts.

- 5 If all else fails,** contact Conair Customer Service. See Appendix page A-1.

---

Conair has made the largest investment in customer support in the plastics industry. Our service experts are available to help with any problem you might have installing and operating your equipment. Your Conair sales representative also can help analyze the nature of your problem, assuring that it did not result from misapplication or improper use.

## WE'RE HERE TO HELP

To contact Customer Service personnel, call:



**From outside the United States, call: 814-437-6861**

## HOW TO CONTACT CUSTOMER SERVICE

You can commission Conair service personnel to provide on-site service by contacting the Customer Service Department. Standard rates include an on-site hourly rate, with a one-day minimum plus expenses.

### **If you do have a problem, please complete the following checklist before calling Conair:**

- Make sure you have all model, serial and parts list numbers for your particular equipment. Service personnel will need this information to assist you.
- Make sure power is supplied to the equipment.
- Make sure that all connectors and wires within and between the saw and related components have been installed correctly.
- Check the troubleshooting guide of this manual for a solution.
- Thoroughly examine the instruction manual(s) for associated equipment, especially controls. Each manual may have its own troubleshooting guide to help you.
- Check that the equipment has been operated as described in this manual.
- Check accompanying schematic drawings for information on special considerations.

## BEFORE YOU CALL ...

*Additional manuals and prints for your Conair equipment may be ordered through the Customer Service or Parts Departments for a nominal fee.*

---

## EQUIPMENT GUARANTEE

Conair guarantees the machinery and equipment on this order, for a period as defined in the quotation from date of shipment, against defects in material and workmanship under the normal use and service for which it was recommended (except for parts that are typically replaced after normal usage, such as filters, liner plates, etc.). Conair's guarantee is limited to replacing, at our option, the part or parts determined by us to be defective after examination. The customer assumes the cost of transportation of the part or parts to and from the factory.

## PERFORMANCE WARRANTY

Conair warrants that this equipment will perform at or above the ratings stated in specific quotations covering the equipment or as detailed in engineering specifications, provided the equipment is applied, installed, operated and maintained in the recommended manner as outlined in our quotation or specifications.

Should performance not meet warranted levels, Conair at its discretion will exercise one of the following options:

- Inspect the equipment and perform alterations or adjustments to satisfy performance claims. (Charges for such inspections and corrections will be waived unless failure to meet warranty is due to misapplication, improper installation, poor maintenance practices or improper operation.)
- Replace the original equipment with other Conair equipment that will meet original performance claims at no extra cost to the customer.
- Refund the invoiced cost to the customer. Credit is subject to prior notice by the customer at which time a Return Goods Authorization Number (RGA) will be issued by Conair's Service Department. Returned equipment must be well crated and in proper operating condition, including all parts. Returns must be prepaid.

Purchaser must notify Conair in writing of any claim and provide a customer receipt and other evidence that a claim is being made.

## WARRANTY LIMITATIONS

**Except for the Equipment Guarantee and Performance Warranty stated above, Conair disclaims all other warranties with respect to the equipment, express or implied, arising by operation of law, course of dealing, usage of trade or otherwise, including but not limited to the implied warranties of merchantability and fitness for a particular purpose.**



---

## Conair Servo Traveling Saw Operator Control Instructions

The Operator Control provides an intuitive user-friendly method to interface with the Conair Servo Traveling Saw. Information is viewed and entered at the Operator Control and is communicated to the servo positional amplifier via the RS-232 serial communication link.

The Operator Control is a flat membrane panel consisting of 22-keys and a large 2 line x 20 back lit LCD screen.



### Soft Keys

Soft keys - these are the three keys directly under the display. All three have a triangle on them. Occasionally, pages will appear that allow the operator to use one of the soft keys. On those occasions, text would typically appear directly above the key and the key will have a function. Think of the text as the soft key function indicator or title.

---

# **Conair Servo Traveling Saw Operator Control Instructions**

## **Numeric keys**

These are the black keys containing numbers 0 to 9. Numbers permit data entry of parameters. See Raise and Lower for value trim.

## **Fixed Function Keys (at Bottom)**

Underneath the numeric keys are fixed function keys. They contain universal symbols and text. The fixed function keys are Raise, Lower, Next, Prev (previous), Enter, Delete, Exit, Menu and Mute. These functions are described in the "Function keys - Fixed Functions" section of this manual.

## **LCD Screen**

The screen shows various pages depending on operator actions. In addition, it is used to indicate warnings. Mostly, it is used for viewing status and for setting parameters.

---

# Conair Servo Traveling Saw Operator Control Instructions

## Contents

Page 4	.....Power up Sequence
Page 5	.....Main Screen – Length Counter .....Count On/Off
Page 6	.....Total .....Total Reset .....Total On/Off
Page 7	.....Length Preset .....Total Reset
Page 8	.....Homing
Page 9	.....Home Already
Page 10	.....Menu Area .....Password Access
Page 11	.....Maintenance Area .....Encoder Direction
Page 12	.....Preventive Maintenance Area .....Power On Time
Page 13	.....Machine Cycles .....Table Speeds
Page 14	.....Table Return Speed
Page 15	.....Table Advance Speed
Page 16	.....Factory Area .....Error Message

---

## Conair Servo Traveling Saw Operator Control Instructions

### Power Up Sequence

At power up a series of system screens briefly appear. The software is Red Lion's Edict-97. This screen or similar shows first.

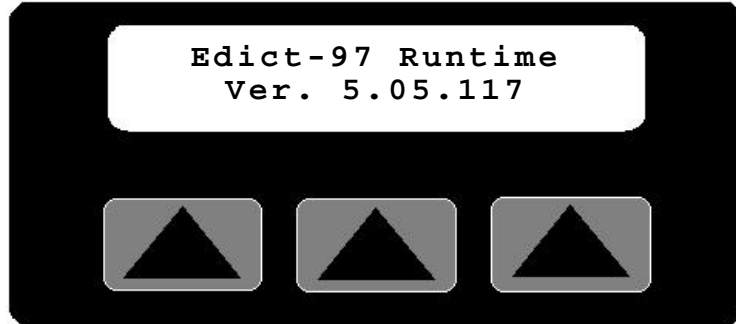

Next, the Communications message appears



If there are any problems with communications, this screen will remain on longer than a couple of seconds.

If there are no communication problems the Conair Servo Traveling Saw program will begin to run. The following

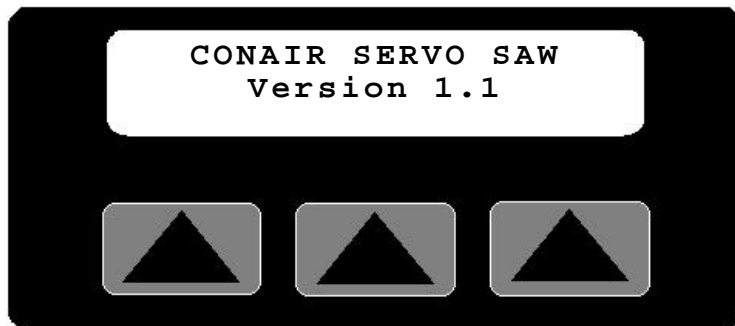

message or similar shows for 5-seconds.  
After the 5 second delay the Main Screen will appear.

---

## Conair Servo Traveling Saw Operator Control Instructions

### Main Screen

The Main Screen has three features. The top line displays the Length Counter. The bottom line contains the two soft key functions, Total and Length.

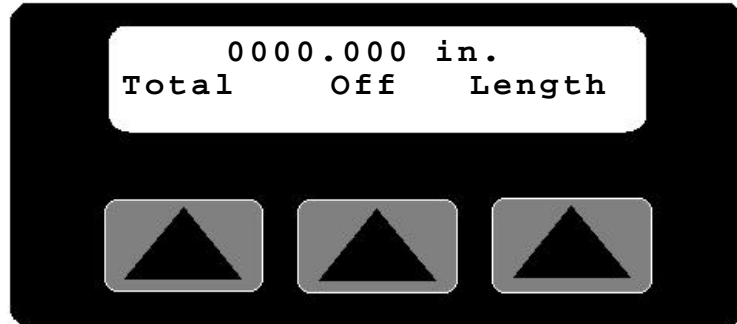

### Length Counter

The Length Counter displays counts only when the machine is started and soft key On/Off is on. If the machine is stopped or soft key On/Off is off, this counter will be forced to zero.

The length counter resides in the servo drive. The main screen shows snapshots of the count value that is read over the communications channel. A slight delay in updates will be noticed.

If a negative symbol is shown to the left of the count value, the encoder signal is reversed, i.e. rotating in the wrong direction. The Saw will not function while the encoder is going negative. It is possible to correct this by using the Direction function on the Maintenance Area page found in the Menu area. This will be shown later in the Menu section of this manual.

### On/Off Softkey

Under the count in the center of the bottom line of the display is a soft key labeled On or Off. Pressing this key while On is displayed will disable the counter. Likewise pressing this key while Off is displayed enables the counter. Pressing the stop button forces the counter off.

---

## Conair Servo Traveling Saw Operator Control Instructions

### Total Softkey

By pressing the soft key located under the word Total on the Main Screen, a six-decade total counter is available.

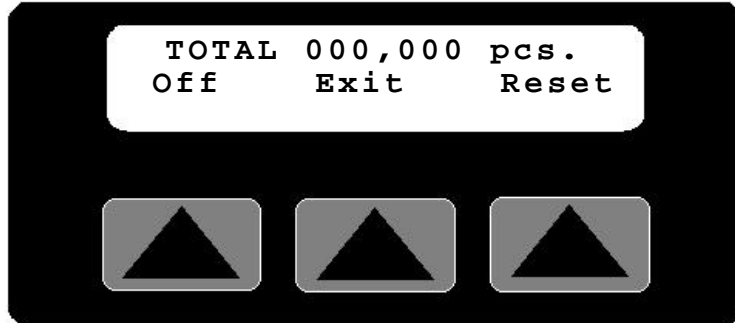

### Total Screen

This is typically used to count cut pieces during the day or days that the product is being produced.

Sample or aborted cuts are not counted. It is also possible to turn this counter off or on.

### Reset Softkey

Under the counter, on the right is a soft key labeled Reset. Pressing this key will zero the counter.

### Exit Softkey

Under the counter, in the center is a soft key labeled Exit. Pressing this key will return the display to the Main screen.

### On/Off Softkey

Under the counter on the left is a soft key labeled On or Off. Pressing this key while On is displayed will disable the counter. Likewise pressing this key while Off is displayed enables the counter.



**EXIT or PREV, fixed function keys return the display to the Main screen.**

---

## Conair Servo Traveling Saw Operator Control Instructions

### Length Softkey

By pressing the soft key located under the word Length on the Main Screen, the preset for the Length counter is available.

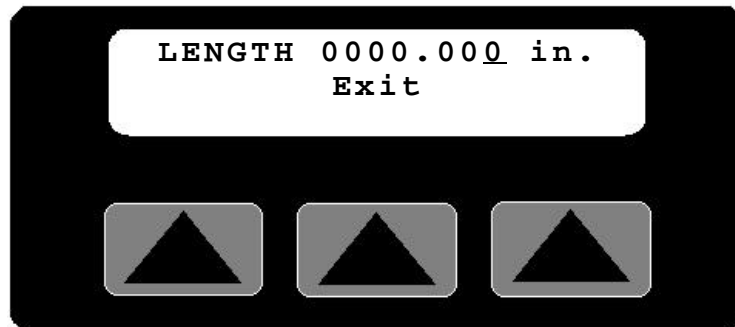

The number shown is the current length preset value, i.e. the length to cut the product. A cursor will appear in the least significant digit. The user has a choice of ways to adjust this number.



**Exit or Prev-** if no change is required press Exit or Prev to return to the Main screen.



**Raise** will increase the preset by 0.01". The key can be pressed once for each 0.01" increment required or held down to scroll up. Releasing the key will freeze the preset at the last value.



**Lower** will decrease the preset by 0.01". The key can be pressed once for each 0.01" decrement required or held down to scroll down. Releasing the key will freeze the preset at the last value.

### Numeric keys

Key in the length required and press enter. The decimal place is fixed so remember this when entering the preset. If you require 24 inches you must key in 24000 and then press enter. Keying only 24 will set the length to 0.024 inches.

### Enter or Delete?

If the keyed in number is correct press the enter key for it to be accepted and return to the Main screen. If it is wrong press the delete key and the previous preset will reappear.

---

# Conair Servo Traveling Saw Operator Control Instructions

## Homing

A defined Home location is required for all servo-positioning applications. After initial power up, Home must be found. All moves are relative to the home location.

The Home cycle occurs once after initial power up in response to the Start push button being pressed.

There are two kinds of home sequence, home seek and home already.

## Home Seek

If the saw table has been stopped away from the home location and the power to the machine switched off, upon

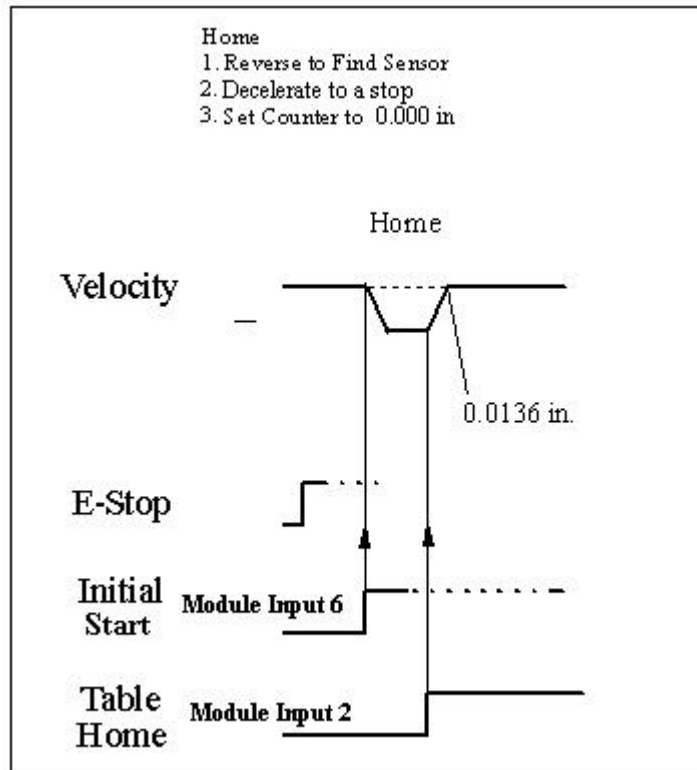

reapplying power, the first motion will be a home seek.

Pressing the start push button begins the home seek cycle. The table reverses towards the home sensor at reduced speed. Once it finds the home sensor, the table will decelerate to a stop approximately 0.0136 in. later. This position is set to 0.000 at end of home.



---

## Conair Servo Traveling Saw Operator Control Instructions

### Home Already

It is possible for the table to be in the home area already. In this case, the table will move forward until it moves off the home sensor. After this, motion is similar to the previous description.

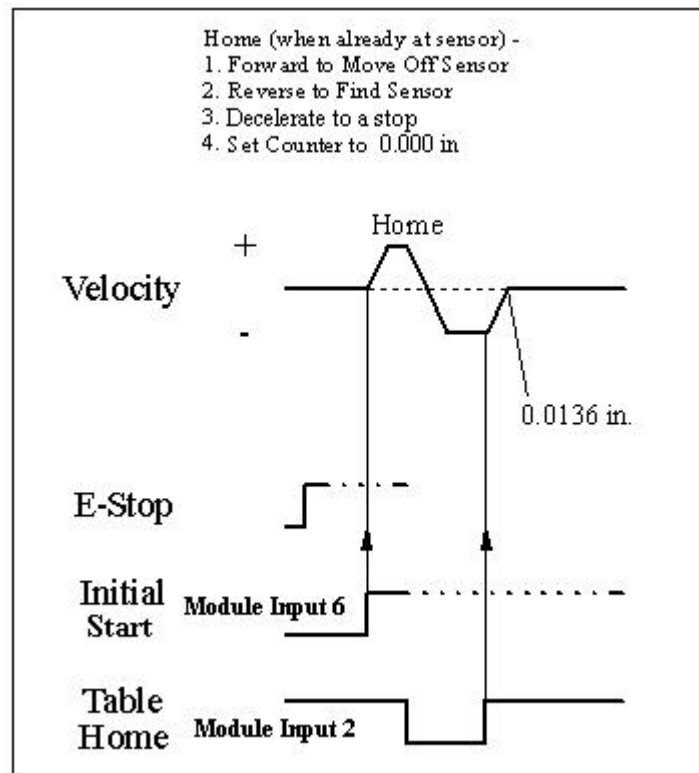

After a successful home has been completed, if the saw is stopped and the power to the machine is left on, the table position is still known. When the saw is restarted, the table will return at the cut cycle, table return speed.

---

## Conair Servo Traveling Saw Operator Control Instructions

### MENU AREA

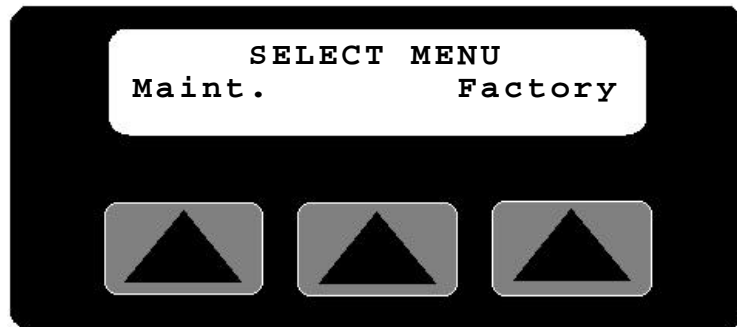

**Menu** function key is used to access the various Menu areas. There are two menus Maint. and Factory, with access via password to various sub-menus.

Menus are a convenient way to access parameters that do not need to be altered often, i.e. table speeds and encoder direction. In addition, preventive maintenance parameters can be monitored for scheduling purposes.

#### **Maint. Softkey**

Located under the word Maint. is the Maintenance soft key. The Maintenance area is password protected. This area should only be accessed by qualified personal. After pressing the Maintenance Softkey, the password entry screen is displayed.



With the numeral keys press 6 2 0 9 then the Enter key to access the maintenance area. An improper password will cause this message to be displayed for 3 seconds.

THE PASSWORD ENTERED  
WAS INCORECT!

---

## Conair Servo Traveling Saw Operator Control Instructions

### Maint. Area

There are three sub-menus, Dirctn, P/M, and Table accessible in the maintenance area.

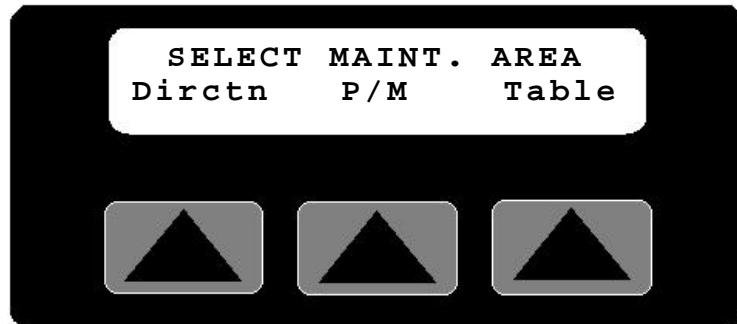

**Exit or Prev-** Pressing Exit or Prev will return the display to the Menu Area screen.

### Dirctn Softkey

By pressing the soft key located under the word Dirctn on the Maint. Area Screen, the direction of the encoder can be changed.

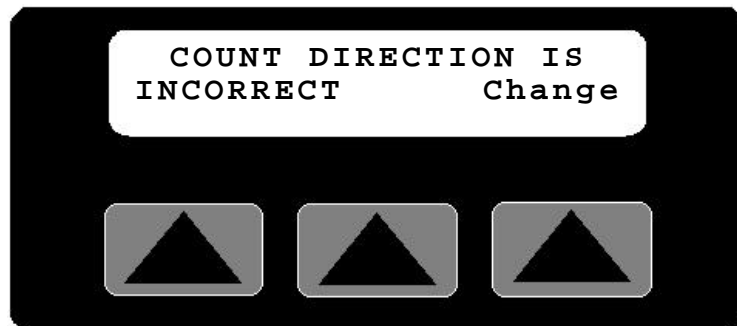

Located on the lower left side of the display is the status text (INCORRECT/CORRECT) for the encoder direction.



**Exit or Prev-** Pressing Exit or Prev will return the display to the Maint. Area screen.

### Change Softkey

With the machine stopped, by pressing the soft key located under the word Change. The direction of the encoder is reversed. After the change if the count direction is positive, the status text will now display the word CORRECT.

---

## Conair Servo Traveling Saw Operator Control Instructions

### P/M Softkey

Pressing the soft key located under the word P/M on the Maint. area screen. Selects the P/M area screen. Two preventive maintenance sub-menus, Time and Cycles can be displayed.

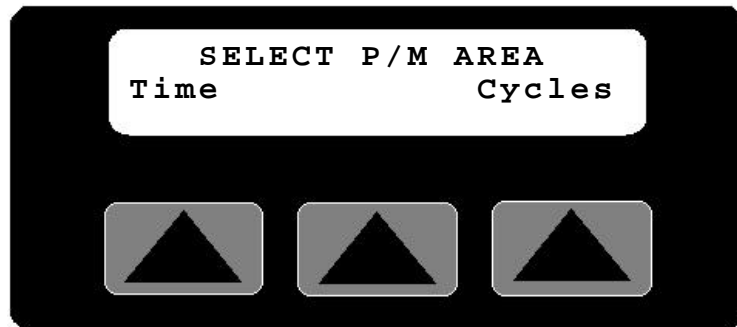

### Time Softkey

Pressing the soft key located under the word Time on the P/M area screen, selects the power-on time screen.

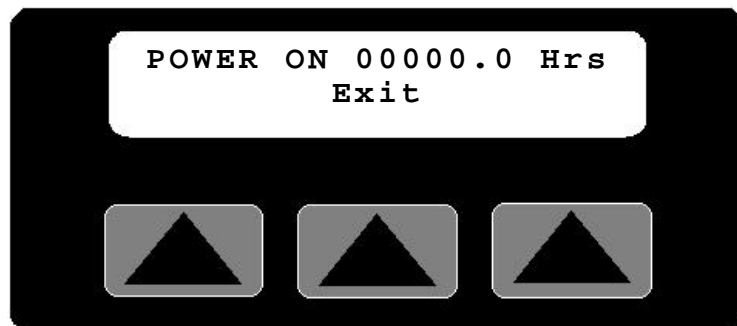

The Power-On time screen displays the total time in hours that the machine has had the power switched on. This information could be used for scheduling preventive maintenance. The displayed time can not be reset.



**Exit or Prev-** Pressing Exit, Prev or the Softkey under the word Exit returns the display to the P/M area screen.

---

## Conair Servo Traveling Saw Operator Control Instructions

### Cycles Softkey

Pressing the soft key located under the word Cycles on the

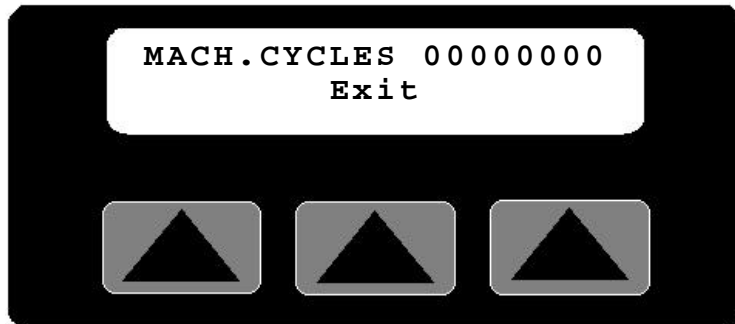

P/M area screen, selects the machine cycles screen.

The Machine Cycles screen displays the total cycles that the machine has completed. This information could be used for scheduling preventive maintenance. The displayed total can not be reset.



**Exit or Prev-** Pressing Exit, Prev or the Softkey under the word Exit returns the display to the P/M area screen.

### Table Softkey

Pressing the soft key located under the word Table on the Maint area screen. Selects the Table area screen. Two table

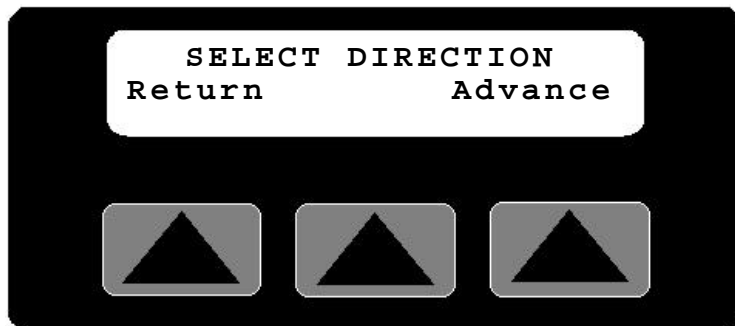

travel direction sub-menus, Return and Advance can be displayed.



**Exit or Prev-** Pressing Exit or Prev returns the display to the Maint area screen.

---

## Conair Servo Traveling Saw Operator Control Instructions

### Return Softkey

Pressing the soft key located under the word Return on the

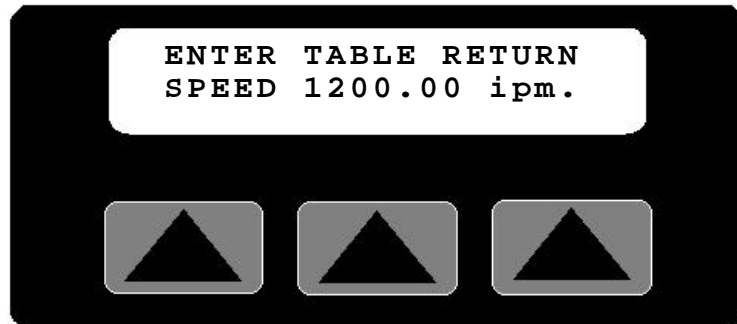

Table area screen. Selects the Table Return Speed screen. The number shown is the current return speed in inches per minute. A cursor will appear in the least significant digit. The user has a choice of ways to adjust this number. **The acceptable range is 120.00-1800.00 ipm**



**Exit or Prev-** if no change is required press Exit or Prev to return to the Table area screen.



**Raise** will increase the preset by 10.00 imp. The key can be pressed once for each 10.00 ipm increment required or held down to scroll up. Releasing the key will freeze the preset at the last value.



**Lower** will decrease the preset by 10.00 ipm. The key can be pressed once for each 10.00 ipm decrement required or held down to scroll down. Releasing the key will freeze the preset at the last value.

### Numeric keys

Key in the speed required and press enter. The decimal place is fixed so remember this when entering the preset. If you require 1200 inches per minute you must key in 120000 and then press enter. Keying only 1200 will set the speed to 12.00 inches per minute and the out of range warning will appear on the screen for 5 seconds.

### Enter or Delete?

If the keyed in number is correct press the enter key for it to be accepted and return to the Main screen. If it is wrong press the delete key and the previous preset will reappear.

---

## Conair Servo Traveling Saw Operator Control Instructions

### Advance Softkey

Pressing the soft key located under the word Advance on the Table area screen. Selects the Table Advance Speed screen.

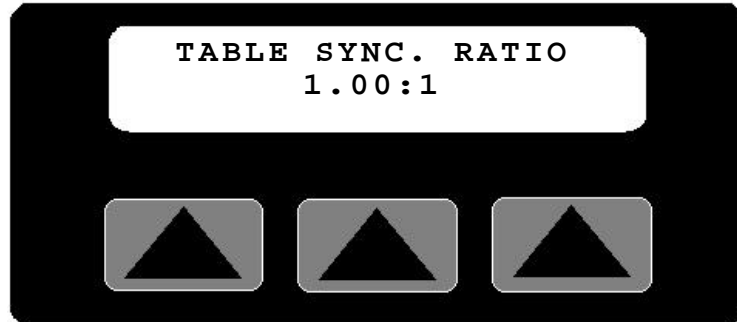

The number shown is the current table advance speed to encoder speed ratio. A cursor will appear in the least significant digit. The user has a choice of ways to adjust this number. **The acceptable range is 1.20-0.80 to 1 (+/- 20%)**



**Exit or Prev**-if no change is required press Exit or Prev to return to the Table area screen.



**Raise** will increase the preset by 0.01. The key can be pressed once for each 0.01 increment required or held down to scroll up. Releasing the key will freeze the preset at the last value.



**Lower** will decrease the preset by 0.01. The key can be pressed once for each 0.01 decrement required or held down to scroll down. Releasing the key will freeze the preset at the last value.

### Numeric keys

Key in the speed required and press enter. The decimal place is fixed so remember this when entering the ratio. If you require a 1.10:1 ratio you must key in 110 and then press enter. Keying only 11 will set the ratio to 0.11 and the out of range warning will appear on the screen for 5 seconds.

### Enter or Delete?

If the keyed in number is correct press the enter key for it to be accepted and return to the Main screen. If it is wrong press the delete key and the previous preset will reappear.

---

## Conair Servo Traveling Saw Operator Control Instructions

### (MENU AREA)

#### Factory Softkey

This area is password protected for factory use only.  
Please do not attempt to get around the password protection

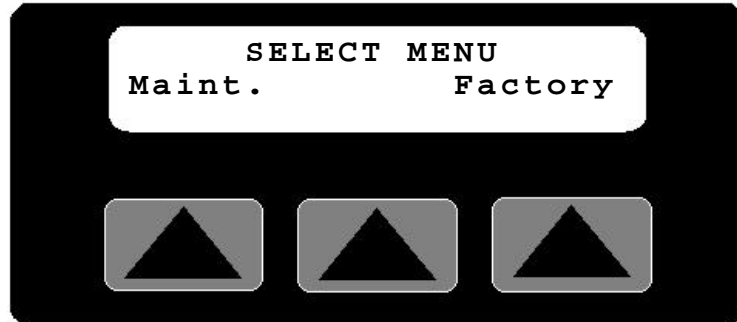

as parameters beyond this point are used for calibration and setup. These parameters should only be modified by trained personal. Improper settings will reduce the performance and possibly cause severe damage to your machine.

### ERROR MESSAGE

If a cut has not completed within a safe amount of table travel this message is displayed. The message will remain until any key is pressed.



The saw will continue to attempt making cuts, but parts will not be added to the total.

Corrective action would be to increase the speed of the blade travel or reduce the amount of blade travel. Either action will reduce the amount of table travel used while making a cut.





EQUIPMENT PARTS LIST  
 TO ORDER PARTS CALL TOLL FREE (800) 458-1960

Product: Saw CTS-5  
 REV #: 023525L020/0703  
 Instruction Manual:

Model No.: CTS-5  
 Serial No.: 148840

Assembly / Part Number (s)

Wiring Diagram Number (s)

\_\_\_\_\_  
 \_\_\_\_\_  
 \_\_\_\_\_

\_\_\_\_\_  
 \_\_\_\_\_  
 \_\_\_\_\_

Reference Number	Part Number	Qty	Description
	<b>General</b>		
1	26682401	4	Caster, 3-1/4" diameter
2	191-668-1105	4	Jack Screw Assembly
	<b>Blades Opt.</b>		
3	2667760103	1	Blade, 18", 48 Tooth
	<b>Table Assembly, Pneumatic / Servo</b>		
4	26678001	6	V Roller, Steel
5	29031102	2	Bearing, Flange 2 Bolt
6	26676701	1	Motor, Saw Arbor
7	26677901	4	Roller, Adjustable Height
8	29037407	1	Cylinder, 6" Stroke (Motor)
9	26677301	1	Belt, Plastic Conveyor 28"x 64"
10	29031102	2	Bearing, Flanged
11	29120631	1	Knob, Black Plastic
12	2990151001	1	Bearing, Bronze
13	29901930	1	Spring, SS

\* Indicates recommended spare parts | ▷ Indicates revisions change | *Italicized* indicates typographical



EQUIPMENT PARTS LIST  
 TO ORDER PARTS CALL TOLL FREE (800) 458-1960

Product:CTS-5  
 REV #: 023525L020/0703  
 Instruction Manual:

Reference Number	Part Number	Qty	Description	2 of 3
	<b>Servo Opt. / Table Travel</b>			
14	20974117	1	Motor, Servo 3000rpm	
15	29051011	1	Reducer, Gear 10:1	
16	29908007	4	Bearing, Flanged	
17	2905320340850	1	Sheave, Timing	
18	29053632	1	Bushing, Sheave	
19	2905320400850	1	Sheave, Timing	
20	29053631	1	Bushing, Sheave	
21	2905320640850	1	Sheave, Timing	
22	29053633	1	Bushing, Sheave	
23	2905338800850	1	Belt, Timing	
24	29053322000850	1	Belt, Timing	
25	26671748	2	Prox. Inductive	
26	26671810	2	Prox. Cable	
27	26676901	1	Switch, Magnetic	
28	26667660101	2	Solenoid Valve	
29	315-165-1012	4	Exhaust	
30	315-167-3007	1	Valve, Quick Exhaust	
31	315-163-2017	1	Gauge, 0-100psi	
32	315-167-2129	1	Flow, Control	
33	315-167-3013	5	Exhaust	
34	266-766-02	1	Manifold	
35	315-170-1001	1	Filter, Regulator, Lubricator	
36	26635304	1	Encoder, 3000PPR	
37	1545-30096	1	Wheel, Encoder	
38	71301811	1	Bracket, Arm	
39	17302403	1	Arm Aluminum	

\* Indicates recommended spare parts | ▷ Indicates revisions change | *Italicized* indicates typographical



EQUIPMENT PARTS LIST  
 TO ORDER PARTS CALL TOLL FREE (800) 458-1960

Product: CTS-5  
 REV #: 023525L020/0703  
 Instruction Manual:

Reference Number	Part Number	Qty	Description	3 of 3
	<b>Electrical Control, 3hp 230/460v (7140360201)</b>			
40	27500675	1	Switch Assy. Disconnect	
41	27501514	1	Contact, Aux. 1N.O. 1N.C.	
42	20973414	1	Breaker, Circuit	
43	27500202	1	Contactor, Non Rev. 12 Amp	
44	27500923	1	Contacts, Aux. 2N.O. 2N.C.	
45	27500109	1	Transformer, 250VA 240/480v	
46	20801476	1	Receptacle, Amphenol, 4 Pin	
47	20801459	1	Connector, Amphenol, 10 Pin	
48	26671601	2	Relay	
49	26671602	2	Relay	
50	1605-30000	1	Relay, Time	
51	1608-30000	7	Semi-Cond. Varistor	
52	26666702	1	Connector, Cable Gland	
	<b>230 Volt</b>			
53	27501510	1	Starter, 6.3-10.0 Amp	
54	20604012	2	Fuse, 1.5 Amp Type FNQ	
55	1646-30192	1	Receptacle, Flanged	

\* Indicates recommended spare parts | ▷ Indicates revisions change | *Italicized* indicates typographical