

Panasonic

Digital Proprietary Telephones
for Digital Super Hybrid Systems

Operating Instructions

Model **KX-T7420**
KX-T7425
KX-T7431
KX-T7433
KX-T7436



Please read this manual before using the
Digital Proprietary Telephone.

Thank you for purchasing a Panasonic Telephone.

Accessories

When unpacking, check the following items.

Handset one
Telephone line cord one
Handset cord one
Overlay one (KX-T7431, KX-T7433 and
KX-T7436 only)
Card holder with memory station card one (KX-T7420, KX-T7425 only)

Warning:

This is a Class A Product. In a domestic environment this product may cause radio interference in which case the user may be required to take adequate measures.

This Systemtelephone complies with the EU Directives.

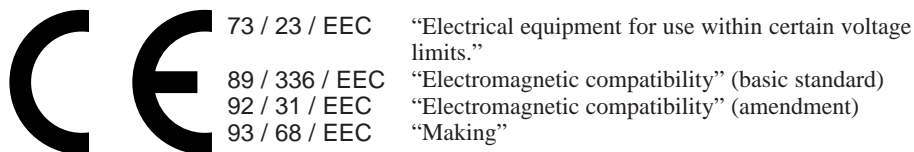

The CE mark on this Systemtelephone certifies compliance with the above mentioned Directives.

For your future reference

SERIAL NO. _____ DATE OF PURCHASE _____
(found on the bottom of the unit)

NAME OF DEALER _____

DEALER'S ADDRESS _____

Contents

Location of Controls	4
Getting Started	6
Connection	6
Controlling the volume/adjusting the display contrast	6
Description of the symbols	7
Making Calls	8
Calling	8
Speed dialling	8
One-touch dialling	8
Dialling the last number you dialled (Last Number Redial)	8
Receiving Calls	9
Receiving calls	9
Handsfree answerback	9
Picking up a call for someone else (Call Pickup)	9
When the Dialed Extension is Busy/No Answer	10
Reserving a busy line (Automatic Callback Busy)	10
Leaving a call notification (Message Waiting)	10
Calling Back	11
When you receive a notification (Message Waiting)	11
Calling using the call log (Incoming Call Log)	11
During a Conversation	12
Placing a call on hold	12
Transferring a call	12
Off-hook Monitor	13
Handset Microphone Mute	13
Paging	13
Paging a person and transferring a call	14
Answering an announced page	14
Answering a call waiting	14
Useful Features	15
Forwarding your calls (Call Forwarding)	15
Preventing others from disturbing you (Do Not Disturb [DND])	16
Three-party conversation (Conference)	17
Ringing tone selection for CO buttons	18
Storing numbers for One-touch dialling	18
How to Use the Display	19
Using the Jog Dial	19
KX-T7431	20
KX-T7433	21
KX-T7436	23
Storing in Speed Dialling	25
Storing names and numbers at your extension for personal use	25
Storing names and numbers in the system	27
Wall Mounting	28
Installing the Card Holder	29
Features List	30
Caution	32

Location of Controls

KX-T7431

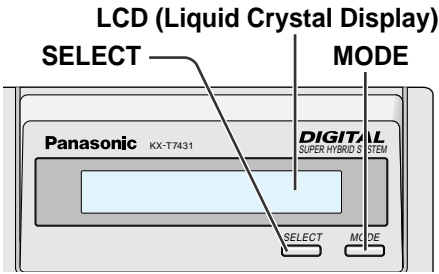

KX-T7433

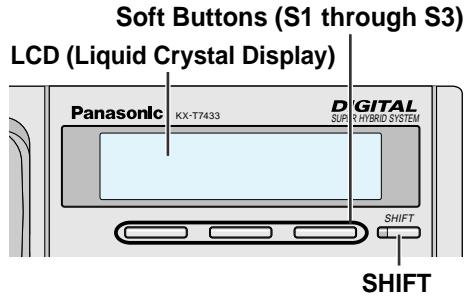

KX-T7436

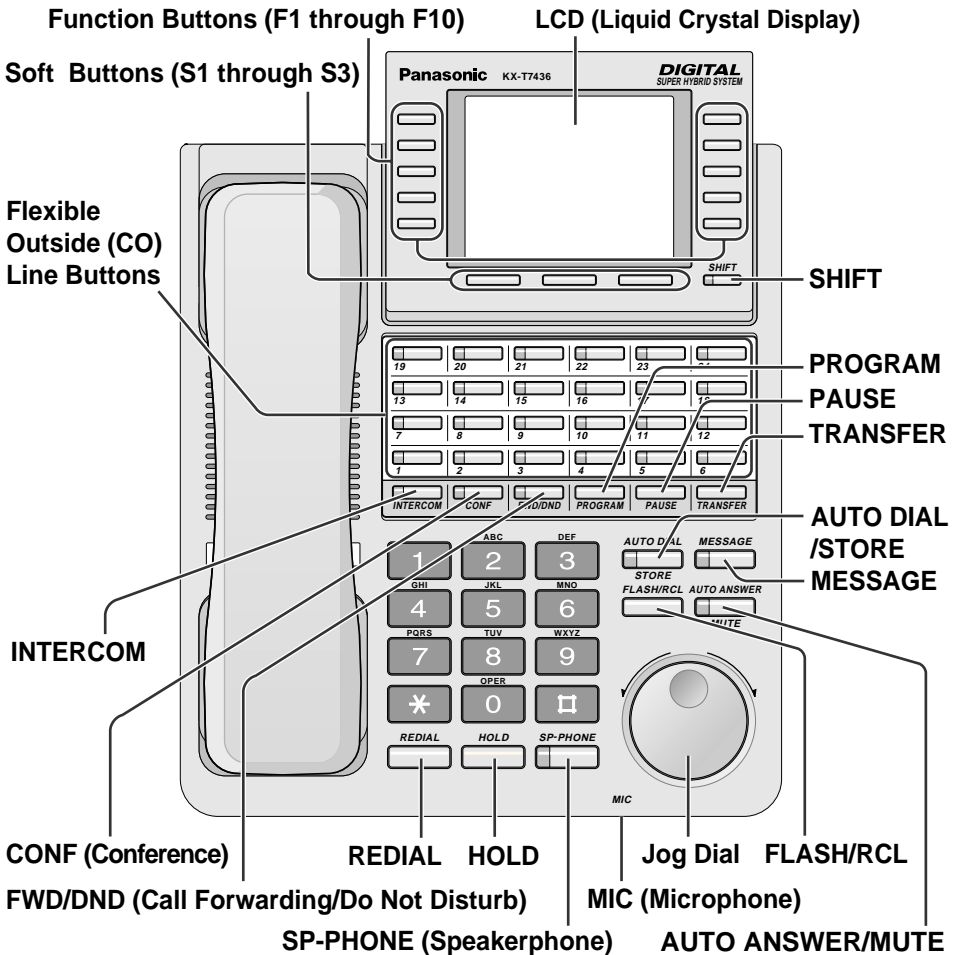

* The KX-T7420 and KX-T7425 are non-display models.

AUTO ANSWER
Used to answer an intercom call automatically.



MUTE

Used to listen to the other party without them hearing you.

AUTO DIAL/STORE
Used for speed dialling in the system or storing program changes.



CONF

Used to make a three-party conference.

FLASH/RCL
Used to disconnect the current call and make another call with holding the same outside line.



Flexible Outside (CO) Line Button

Used to make or receive an outside call, or access a feature if the button is assigned as a One-touch dialling button.



Function Button

Used to perform the displayed function or operation.



FWD/DND
Used to perform Call Forwarding or Do Not Disturb.



HOLD

Used to place a call on hold.



INTERCOM
Used to make or receive intercom calls.



Jog Dial

Used to adjust the volume and the display contrast or select desired items for each functions.



MESSAGE
Used to leave a notification or call back the party who left the notification.



MODE

Used to set the display to access a feature.



PAUSE

Used to insert a pause in speed dial numbers or in other numbers.



PROGRAM

Used to enter and exit the programming mode.



REDIAL

Used to redial.



SELECT

Used to select the displayed function or to call the displayed phone number.



SHIFT

Used to alternate the sub function on the display.



Soft Button

Used to perform the function or operation that appears on the bottom line of the display.



SP-PHONE

Used for the handsfree operation.



TRANSFER

Used to transfer a call to another party.



For KX-T7433 and KX-T7436 Users

The display angle can be adjusted.

- 1 Press the **LCD ADJ** button.
- 2 Lift or put down the display.

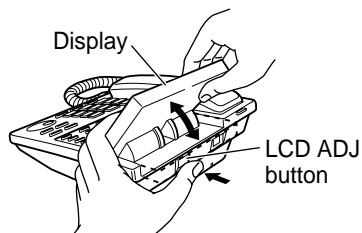

Getting Started

■ Connection

The telephone line cord (included)

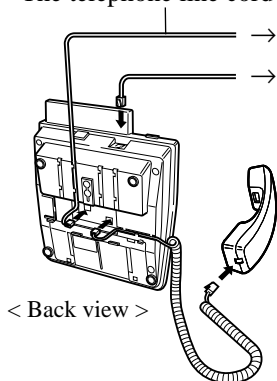

< Back view >

→ Connect to a Digital Super Hybrid System (**TO MAIN UNIT**).

→ Connect to a standard telephone jack (**TO TEL**), telephone answering machine, or fax for XDP* or parallel connections.

* For more details about XDP, consult with your dealer.

Attention

Ensure the cords are inserted in the grooves to prevent damage to the connectors, for both wall mounting and desktop positioning.

■ Controlling the volume/adjusting the display contrast

Speaker volume

- 1 Press the **SP-PHONE** button.
- 2 Rotate the **Jog Dial** in the desired direction.

Handset/Headset volume

- 1 Lift the handset.
(Press the SP-PHONE button for headset volume.)
- 2 Rotate the **Jog Dial** in the desired direction.

For KX-T7420 and KX-T7425 Users

Ringer volume

- 1 Adjust the **RINGER Volume selector** lever to the desired setting (OFF/LOW/HIGH).

RINGER Volume selector

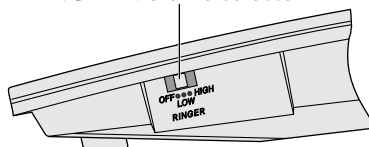

<Side view of the KX-T7420 and KX-T7425>

For KX-T7431 Users

Display contrast

While idle and on-hook

- 1 Press the **MODE** button six times.
Display:
- 2 Rotate the **Jog Dial** in the desired direction.

Ringer volume

While idle and on-hook

- 1 Press the **MODE** button five times.
Display:
- 2 Rotate the **Jog Dial** in the desired direction.

For KX-T7433 and KX-T7436 Users

Display contrast

While on-hook or during a conversation

- 1 Press the **CONT** (S1) button.

Display:

- 2 Rotate the **Jog Dial** in the desired direction.

Ringer volume

While idle and on-hook

- 1 Press the **RING** (S2) button.

Display:

- 2 Rotate the **Jog Dial** in the desired direction.

Description of the symbols

In this manual, many symbols are used. Some of the symbols are described below.



Off-hook

- Lift the handset.
or
- Press the SP-PHONE button.



Press the desired number keys on the telephone.



On-hook

- Replace the handset.
or
- Press the SP-PHONE button.



Various tones are heard depending on the operation.

Helpful hints for the handsfree operation

- **If the other party's voice is difficult to hear;**
Raise the sound level using the speaker volume control.
- **If the other party has difficulty hearing you;**
Lower the speaker volume.
- **Absorbing echoes;**
Use this unit in a room which has curtains and/or carpeting.
- **To avoid missing part of the conversation;**
If you and the other party speak at the same time, parts of your conversation will be lost. To avoid this, speak alternately.

Making Calls

Calling

To an extension

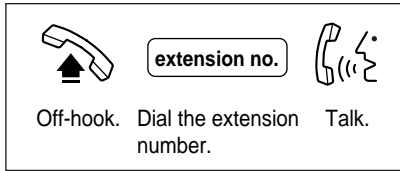

Off-hook. Dial the extension number. Talk.

To an external party

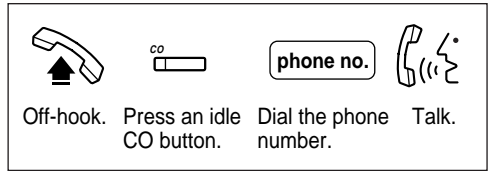

Off-hook. Press an idle CO button. Dial the phone number. Talk.

Speed dialling

Using a speed dial number stored in your telephone

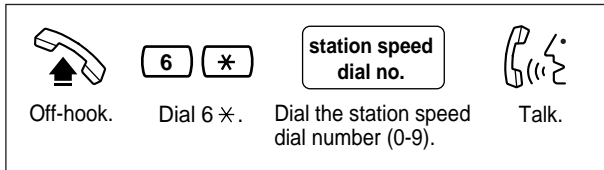

Off-hook. Dial 6 *. Dial the station speed dial number (0-9). Talk.

To store numbers, refer to page 25.

Using a speed dial number stored in the system

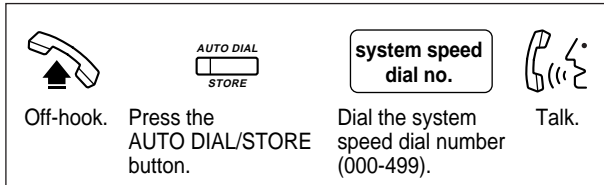

Off-hook. Press the AUTO DIAL/STORE button. Dial the system speed dial number (000-499). Talk.

To store numbers, refer to page 27.

One-touch dialling

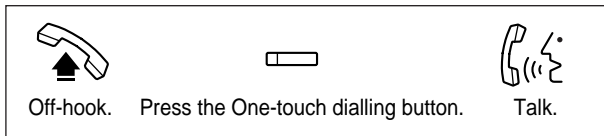

Off-hook. Press the One-touch dialling button. Talk.

To store numbers, refer to page 18.

Dialling the last number you dialled (Last Number Redial)

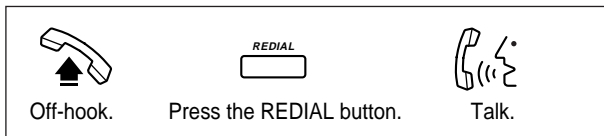

Off-hook. Press the REDIAL button. Talk.

Receiving Calls

Receiving calls

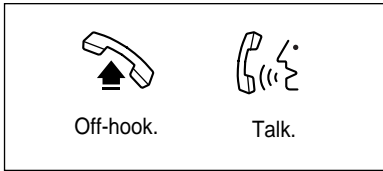

If your telephone rings,

- *Lift the handset or press the SP-PHONE button. (Default: The ringing line is selected.)*
- *Press the rapid flashing green outside (CO) line button or rapid flashing INTERCOM button.*

Handsfree answerback

You can answer an intercom call without lifting the handset.

The AUTO ANSWER/MUTE button light shows the current status as follows.

On: Set

Off: Not set

To set / cancel

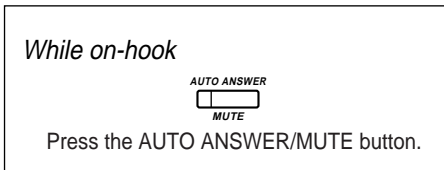

Picking up a call for someone else (Call Pickup)

You can answer an incoming call that is ringing at another extension from your telephone. A call within your extension group can be picked up.

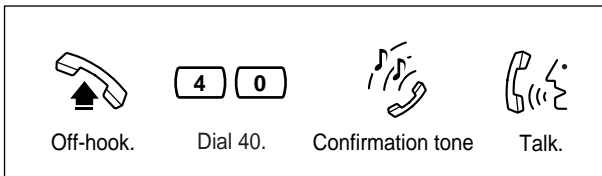





When the Dialed Extension is Busy/No Answer

Reserving a busy line (Automatic Callback Busy)

You can receive a notification when a busy extension becomes free. To answer the notification, lift the handset or press the SP-PHONE button. The called extension starts ringing automatically.

To set

When hearing a busy tone

Dial 6 or press the C.BCK (S3) button.*¹ Confirmation tone On-hook.

To answer and call*²

If you hear call back ringing

 The extension is called automatically.

Off-hook.

*¹ The C.BCK (S3) button is only available for KX-T7433 and KX-T7436 users.



*² If you do not answer after four callback rings, this feature will be cancelled.

Leaving a call notification (Message Waiting)

When the called extension is busy or does not answer, you can leave a notification to have the called extension call you back.



To leave a notification

When the called extension is busy or does not answer

Press the MESSAGE button. Confirmation tone On-hook.

To cancel a notification

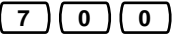
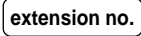
Off-hook. Dial 700. Dial the extension number. Confirmation tone On-hook.

Calling Back

■ When you receive a notification (Message Waiting)

The MESSAGE button lights to let you know that a call has been received.

To check and select the party (display telephone only)

While on-hook



Press the MESSAGE button until the desired message appears.

To call back



Off-hook.



Press the MESSAGE button.



Talk.

To clear all notifications



Off-hook.

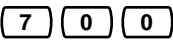

Dial 700.

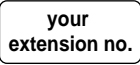

Enter your extension number.



Confirmation tone



On-hook.

■ Calling using the call log (Incoming Call Log)

(KX-T7433/KX-T7436 only)

If you do not answer a call, your telephone automatically records the incoming outside call information with the CLIP (Calling Line Identification Presentation) service*. You can also record the existing call during a conversation or call back the logged numbers. To confirm or call back using the call log, refer to pages 22 (for KX-T7433) and 24 (for KX-T7436).

* The CLIP service provides you with the caller's telephone number.

For more details, consult with your dealer.

To record the information of an existing call

During a conversation



Press the LOG (S2) button.

During a Conversation

Placing a call on hold

The corresponding outside (CO) line button or the INTERCOM button lights show the current status as follows.

Flashing green slowly: Your held call

Flashing red slowly: Another extension's held call

Holding

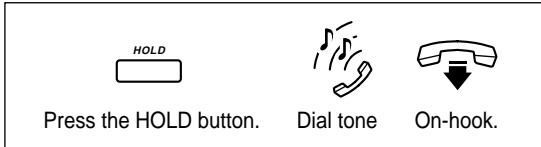

To retrieve a call at the holding extension*1

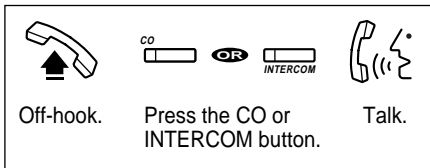

To retrieve an outside call from another extension*1

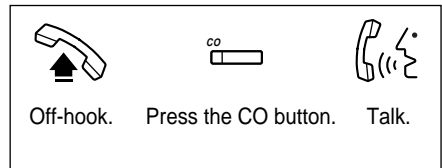

*1 *If a call is not retrieved within a specified time, you will hear an alarm as a reminder.*

Transferring a call

Using the TRANSFER button

To an extension

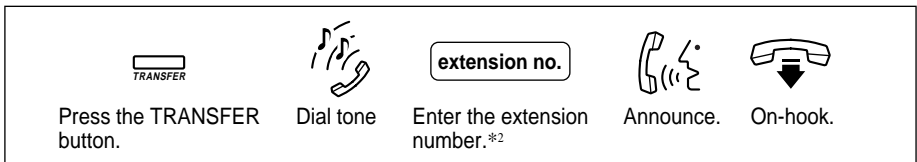

To an external party*3

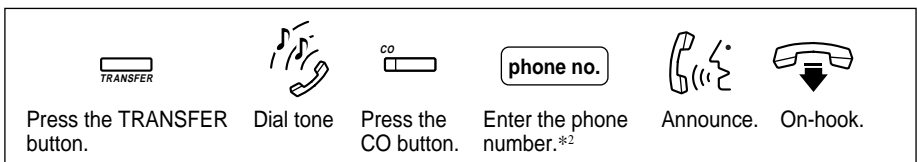

*2 *To retrieve the held call, press the TRANSFER button, corresponding Outside (CO) line button, or the INTERCOM button.*

*3 *Transferring a call to an external party may be restricted by System Programming.*



Off-hook Monitor (KX-T7431/KX-T7433/KX-T7436 only)

You can make other users listen to the conversation through the built-in speaker, while continuing the conversation using the handset.*1

To set

During a conversation using a handset



Press the SP-PHONE button.

To cancel

When the off-hook monitor mode is established



Press the SP-PHONE button.

*1 This is only available during a conversation with the handset.

Handset Microphone Mute

You can turn off the handset microphone so you can consult privately with others in the room. You will still be able to hear the other party.*2

To set

During a conversation using a handset



Press the AUTO ANSWER/MUTE button.

To cancel

When the handset microphone mute is established





Press the AUTO ANSWER/MUTE button.

*2 This is only available during a conversation with the handset.

Paging

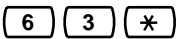



You can make a voice announcement to all people in the office through the telephone speaker and external speaker at the same time.

 Off-hook.	 Dial 63*.*3	 Confirmation tone	 Announce.
--	--	--	--

*3 For KX-TD208 users, dial 630.

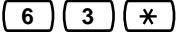







During a Conversation

Paging a person and transferring a call

				
Press the TRANSFER button.	Dial 63*.* ^{*1}	Confirmation tone	Announce and wait for an answer.	On-hook.

^{*1} For KX-TD208 users, dial 630.

Answering an announced page



Through a telephone speaker				
				
Off-hook.	Dial 43.	Confirmation tone	Talk.	
Through an external speaker*²				
				
Off-hook.	Dial 44 and the external pager number.	Confirmation tone	Talk.	

^{*2} The KX-TD816/1232 users only.

Answering a call waiting



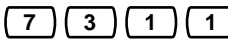
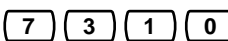
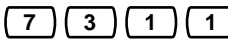
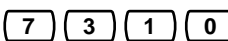

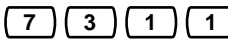
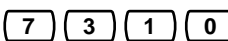
During a conversation, a call waiting tone occurs when an outside call is received or another extension is letting you know that another call is waiting. (Default: Cancel)

To set / cancel

	<table border="0"> <tr> <td></td> <td>To set</td> </tr> <tr> <td></td> <td>To cancel</td> </tr> </table>		To set		To cancel		
	To set						
	To cancel						
Off-hook.	To set: Dial 7311. To cancel: Dial 7310.	Confirmation tone	On-hook.				

To talk to the new party

While hearing a tone

			
Press the HOLD button. ^{*3}	Press the CO or INTERCOM button. ^{*4}		

^{*3} If you terminate the current call, disregard this step.

^{*4} If both parties are extensions, disregard this step.





Useful Features

■ Forwarding your calls (Call Forwarding)

You can have your incoming calls forwarded to another extension or external party.





All calls

All calls are forwarded to another extension.

 Off-hook.	 Press the FWD/DND button.	 extension no. Dial 2 and the extension number.	 Confirmation tone	 On-hook.
--	--	---	--	--





Busy

All calls are forwarded to another extension when your extension is busy.

 Off-hook.	 Press the FWD/DND button.	 extension no. Dial 3 and the extension number.	 Confirmation tone	 On-hook.
--	--	---	--	--





No answer

All calls are forwarded to another extension when you do not answer the call.

 Off-hook.	 Press the FWD/DND button.	 extension no. Dial 4 and the extension number.	 Confirmation tone	 On-hook.
--	--	---	--	--

Busy/No answer (BSY/NA)









All calls are forwarded to another extension when you do not answer or when your extension is busy.

 Off-hook.	 Press the FWD/DND button.	 extension no. Dial 5 and the extension number.	 Confirmation tone	 On-hook.
--	--	---	--	--

Useful Features

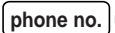



To outside (CO) line

All calls are forwarded to an external party. Some extensions may be restricted.



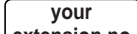

		   		
Off-hook.	Press the FWD/DND button.	Dial 69, the phone number and #.	Confirmation tone	On-hook.

Follow Me (From)





All calls are forwarded to another extension which you set to receive your calls at the receiving extension.

		 		
Off-hook.	Press the FWD/DND button.	Dial 7 and your extension number.	Confirmation tone	On-hook.

Cancelling (except Follow Me)

				
Off-hook.	Press the FWD/DND button.	Dial 0.	Confirmation tone	On-hook.

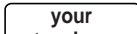



Cancelling Follow Me

		 		
Off-hook.	Press the FWD/DND button.	Dial 8 and your extension number.	Confirmation tone	On-hook.

Preventing others from disturbing you (Do Not Disturb [DND])



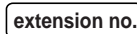

During a meeting or when you are busy, you can refuse an incoming call. You can also forward an incoming outside call to another extension or operator.

Forwarding to another extension





		 		
Off-hook.	Press the FWD/DND button.	Dial 1 and the extension number.	Confirmation tone	On-hook.







Forwarding to an operator

				
Off-hook.	Press the FWD/DND button.	Dial 10.	Confirmation tone	On-hook.

Refusing all calls

				
Off-hook.	Press the FWD/DND button.	Dial 1*.	Confirmation tone	On-hook.





Cancelling

				
Off-hook.	Press the FWD/DND button.	Dial 0.	Confirmation tone	On-hook.

Three-party conversation (Conference)

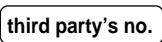



You can add another party during a conversation.

Adding a third party during a conversation

				
Press the CONF button.	Enter the third party's number.*1	Talk to the third party.	Press the CONF button.	Confirmation tone

*1 **To add an external party**, press an outside (CO) line button and dial the phone number.

To talk to one party by terminating the other

			
Press the CO or INTERCOM button.*2			Confirmation tone

Leaving a conference

On-hook.







*2 **This is only available for a combination of one extension and two outside (CO) lines or two extensions and one outside (CO) line.**

Useful Features

■ Ringing tone selection for CO buttons

You can select the desired ringer frequency for each outside (CO) line button.

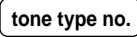







To program

 PROGRAM	 	 		 AUTO DIAL STORE	 PROGRAM
Press the PROGRAM button.	Dial 99.	Press the desired CO button twice.	Enter the tone type number (1 through 8).	Press the AUTO DIAL/STORE button.	Press the PROGRAM button.

■ Storing numbers for One-touch dialling

The stored number is dialled automatically by pressing an outside (CO) line button which is assigned as a one-touch dialling button.

To program

 PROGRAM	 				 AUTO DIAL STORE	 PROGRAM
Press the PROGRAM button.	Dial 99.	Press the desired CO button.	Dial 2.	Enter the desired number.	Press the AUTO DIAL/STORE button.	Press the PROGRAM button.

How to Use the Display

■ Using the Jog Dial

Using the display message and the Jog Dial, KX-T7431, KX-T7433 and KX-T7436 users can make a call or operate the features without programming the feature numbers. The displays used in this page are a KX-T7431.

<p>Extension Dialling</p> <div style="border: 1px solid black; padding: 2px; width: fit-content; margin: 5px auto;">Extension</div>	<p>You can make an intercom call using the directory.</p>	<p>Only items which have a name assigned are displayed in alphabetical order.</p>
<p>System Speed Dialling</p> <div style="border: 1px solid black; padding: 2px; width: fit-content; margin: 5px auto;">System Speed</div>	<p>You can make a call to a party stored in the system using the directory.</p>	
<p>Station Speed Dialling</p> <div style="border: 1px solid black; padding: 2px; width: fit-content; margin: 5px auto;">Station Speed</div>	<p>You can make a call to a party stored in your telephone.</p>	<p>Items which have a name assigned are displayed by priority in stored order. If a name is not assigned, the number is displayed.</p>
<p>System Feature Access</p> <div style="border: 1px solid black; padding: 2px; width: fit-content; margin: 5px auto;">Feature Access</div>	<p>You can access the features which are displayed in alphabetical order.*</p>	

** For more details about the accessible features, refer to your Digital Super Hybrid System manual or consult with your dealer.*

How to Use the Display

KX-T7431

Operating the feature

- 1 Press the **MODE** button repeatedly to set the display to the Jog Dial function (the second to fifth displays).

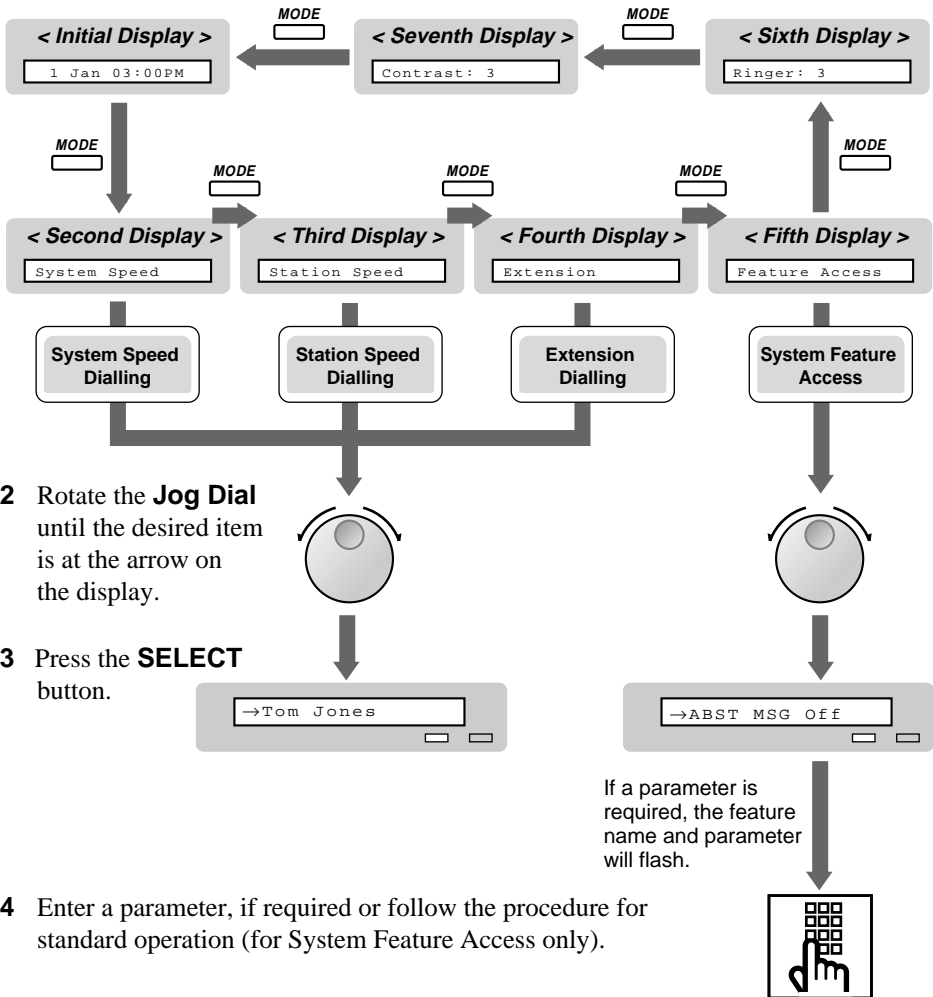

- 2 Rotate the **Jog Dial** until the desired item is at the arrow on the display.
- 3 Press the **SELECT** button.
- 4 Enter a parameter, if required or follow the procedure for standard operation (for System Feature Access only).



KX-T7433

Operating the feature

1 Press the **SHIFT** button repeatedly to set the display to the third display.

- 2 Select the desired feature.*
- Press the **STA** (S1) button (for Station Speed Dialling).
 - Press the **EXT** (S2) button (for Extension Dialling).
 - Press the **FEAT** (S3) button (for System Feature Access).

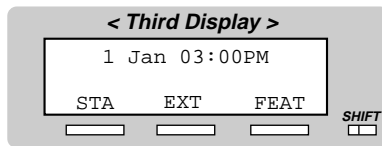

3 Rotate the **Jog Dial** until the desired item is at the arrow on the display.

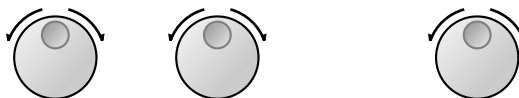

- 4 • Press the **CALL** (S3) button (for System Speed Dialling, Station Speed Dialling and Extension Dialling).
- Press the **SEL** (S3) button (for System Feature Access).

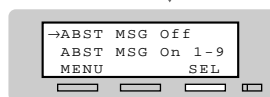
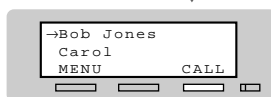
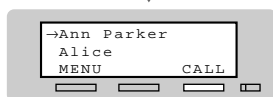

If a parameter is required, the feature name and parameter will flash.

5 Enter a parameter, if required or follow the procedure for standard operation (for System Feature Access only).

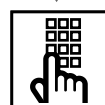

* Step 2 can be skipped for System Speed Dialling.

How to Use the Display

Confirming and calling back using the call log

- 1 Press the **SHIFT** button to set the display to the second display.
- 2 Select the desired call log.
 - Press the **OLD** (S1) button to see the confirmed information.
 - Press the **NEW** (S2) button to see the unconfirmed information.
- 3
 - Press the **INFO** (S1) button to see the information in detail.
 - Press the **NEXT** (S3) button to see another caller's information.

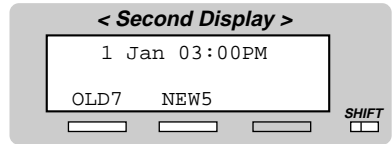

The sequence number and caller's number are displayed.

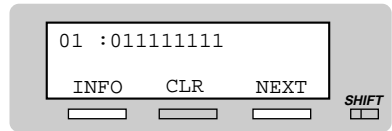

Pressing the INFO button provides you with more information.

- Once: sequence number/caller's name
- Twice: date/time/number of times called
- Three times: outside line number /outside line name

To see another caller's information

- 4 Off-hook.



- 5 Press the **CALL** (S1) button.

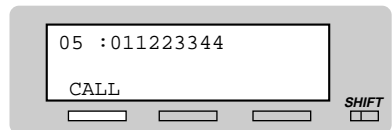



KX-T7436

Operating the feature

- 1 Press the **SHIFT** button repeatedly to set the display to the third display.
- 2 Select the desired feature.*
 - Press the **STA** (S1) button (for Station Speed Dialling).
 - Press the **EXT** (S2) button (for Extension Dialling).
 - Press the **FEAT** (S3) button (for System Feature Access).

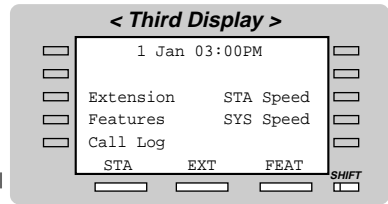

- 3 Rotate the **Jog Dial** until the desired item is at the arrow on the display.
- 4 • Press the **CALL** (S3) button (for System Speed Dialling, Station Speed Dialling and Extension Dialling).
- Press the **SEL** (S3) button (for System Feature Access). Or press the corresponding buttons on the side of the display (Function button).

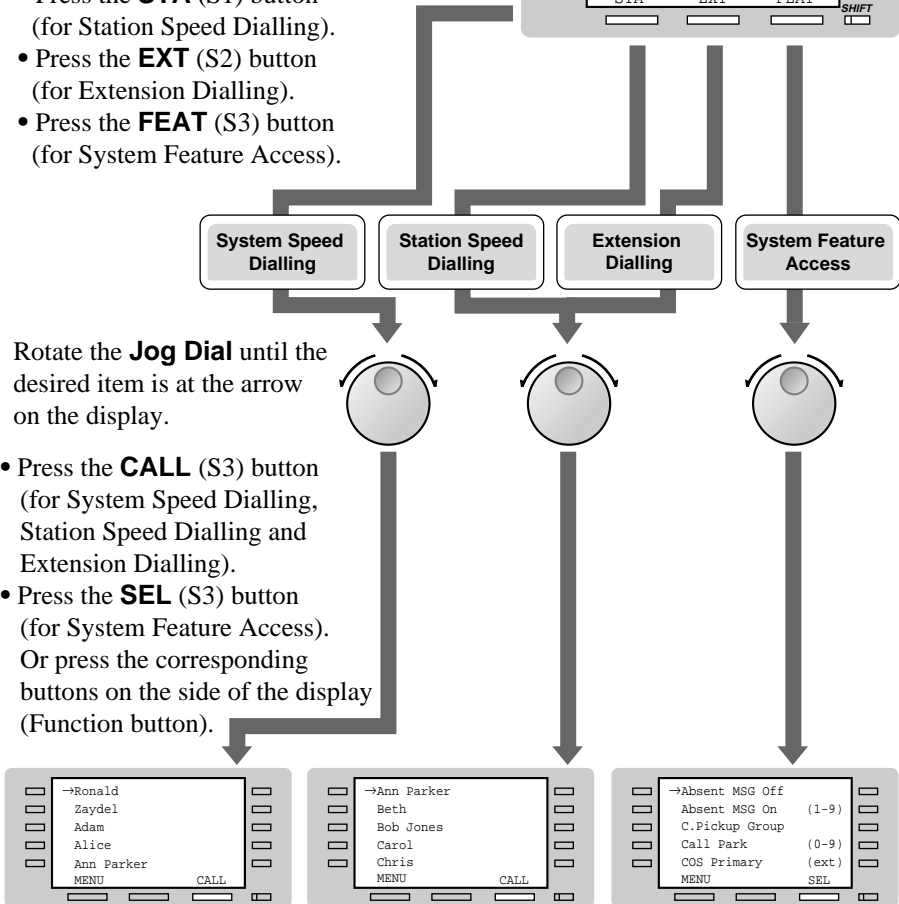

If a parameter is required, the parameter will flash.

- 5 Enter a parameter if required or follow the procedure for standard operation (for System Feature Access only).

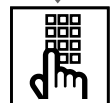

* Step 2 can be skipped for System Speed Dialling.

How to Use the Display

Confirming and calling back using the call log

- 1 Press the **SHIFT** button to set the display to the second display.
- 2 Select the desired call log.
 - Press the Function button (Call Log) to call a number previously dialled (for the outgoing call log).
 - Press the **OLD** (S1) button to see the confirmed call information you received.
 - Press the **NEW** (S2) button to see the unconfirmed call information you received.
- 3 Press the **NEXT** (S3) button to see another caller's information.*
- 4
 - Press the corresponding button on the side of the display (for the outgoing call log).
 - Off-hook (for the incoming call log).
- 5 Press the **CALL** (S1) button.*

Call Log, Outgoing
To make a call using the call log (last five outside calls you dialled).

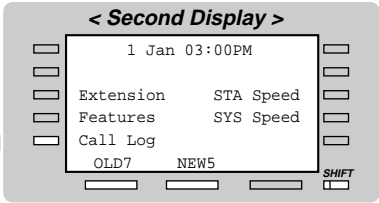
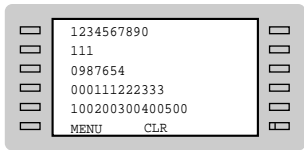

To see the confirmed information

To see the unconfirmed information

Outside line number/name
Caller's telephone number
Caller's name
Date and time
Sequence number
/number of times called

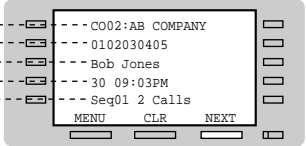

To see another caller's information

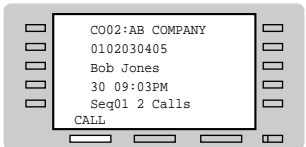



* Step 3 and 5 can be skipped for the outgoing call log.

Storing in Speed Dialling

Storing names and numbers at your extension for personal use

To store a phone number

	<input type="text" value="6"/> <input type="text" value="0"/>	<input type="text" value="station speed dial no."/>	<input type="text" value="phone no."/>	<input type="text" value="#"/>
Off-hook.	Dial 60.	Enter the station speed dial number (0-9).	Enter the phone number (16 digits max.).*1	Dial #.
				
Confirmation tone		On-hook.		

1 “ ” and PAUSE can be also stored as digits.

To store a phone number

– For KX-T7431 and KX-T7433 users *2

<input type="text" value="PROGRAM"/> <input type="text" value="9"/> <input type="text" value="9"/>	To continue		<input type="text" value="station speed dial no."/>	<input type="text" value="desired no."/>
Press the PROGRAM button and dial 99.	<input type="text" value="*"/> <input type="text" value="*"/>	Dial * * and enter the station speed dial number (0-9).	Enter the desired number (16 digits max.).*3	
<input type="text" value="AUTO DIAL STORE"/>			<input type="text" value="PROGRAM"/>	
Press the AUTO DIAL/STORE button.	Confirmation tone		Press the PROGRAM button.	

– For KX-T7436 users

<input type="text" value="PROGRAM"/> <input type="text" value="9"/> <input type="text" value="9"/>	To continue		<input type="text" value="desired no."/>	<input type="text" value="AUTO DIAL STORE"/>
Press the PROGRAM button and dial 99.	<input type="text" value=""/>	Press the desired function button.	Enter the desired number (16 digits max.).*3	Press the AUTO DIAL/STORE button.
	<input type="text" value="PROGRAM"/>			
Confirmation tone	Press the PROGRAM button.			

*2 This is only available for KX-TD816/1232 users.

3 “ ”, “#”, RECALL, SECRET (INTERCOM), - (CONF) and PAUSE can be also stored.

Storing in Speed Dialling

To store a name

– For KX-T7431 and KX-T7433 users *1

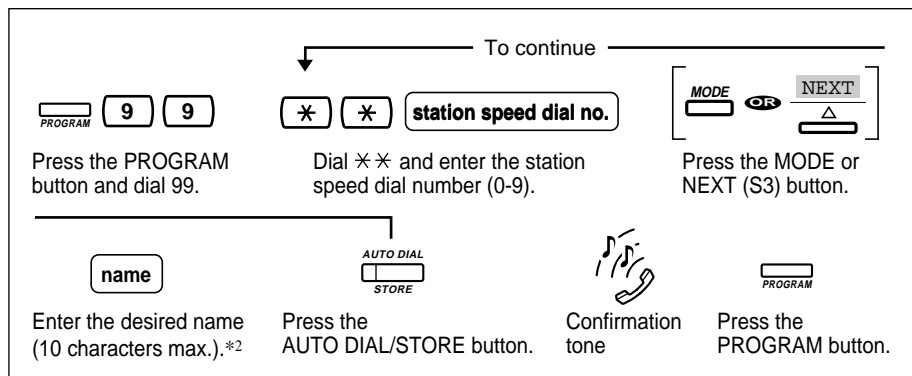

– For KX-T7436 users

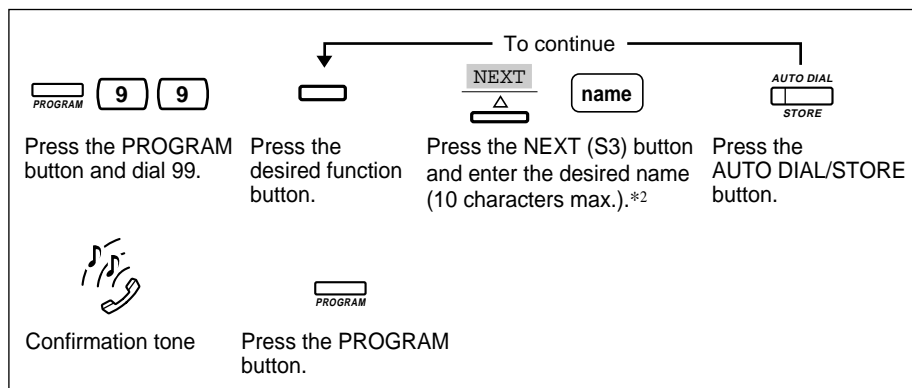

*1 This is only available for KX-TD816/1232 users.

*2 **To enter characters**, press 2 and rotate the Jog Dial to select the character. You can continue entering characters by pressing 2 and using the jog dial repeatedly. To correct a wrong entry, press the TRANSFER button and enter the new one.

Example: To enter “Mike”













- 1 Press 2, rotate the Jog Dial to enter “M”.
- 2 Press 2, rotate the Jog Dial to enter “i”.
- 3 Press 2, rotate the Jog Dial to enter “k”.
- 4 Press 2, rotate the Jog Dial to enter “e”.

Storing names and numbers in the system













(KX-T7431/KX-T7433/KX-T7436 only)

As the stored numbers can be used by all of the users in the system, confirm the stored entries with other users.

To store a phone number

 PROGRAM	 	User Password	  
Press the PROGRAM button.	Dial * *.	Enter the user password.	Dial 001.
 OR 		speed dial no.	desired no.
Press the SP-PHONE or NEXT (S3) button.		Enter the speed dial number (000-499).* ¹	Enter the desired number (24 digits max.).
 AUTO DIAL STORE		 HOLD	 PROGRAM
Press the AUTO DIAL/STORE button.	Confirmation tone* ²	Press the HOLD button.	Press the PROGRAM button.

To store a name

 PROGRAM	 	User Password	  
Press the PROGRAM button.	Dial * *.	Enter the user password.	Dial 002.
 OR 		speed dial no.	desired name
Press the SP-PHONE or NEXT (S3) button.		Enter the speed dial number (000-499).* ¹	Enter the desired name (10 characters max.).
 AUTO DIAL STORE		 HOLD	 PROGRAM
Press the AUTO DIAL/STORE button.	Confirmation tone* ²	Press the HOLD button.	Press the PROGRAM button.

*¹ 100 speed dial numbers (00-99) can be stored in the KX-TD208.

*² You can continue entering the number/name by pressing the NEXT (S3) or SP-PHONE button after the confirmation tone.

Wall Mounting

- 1** Remove the handset hook by pulling it toward the top of the unit. Turn it around and re-insert it.

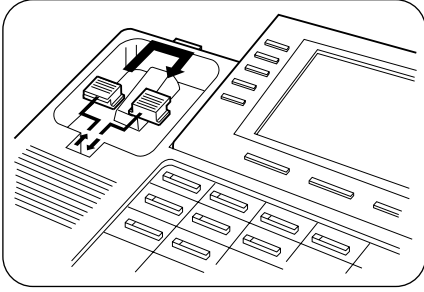

- 4** Insert the stand in the centre slots.

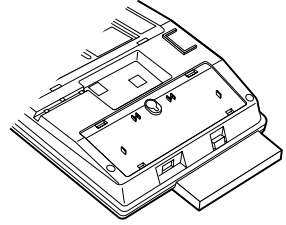

- 2** Remove the attached stand.

- 5** Mount the unit on the wall.

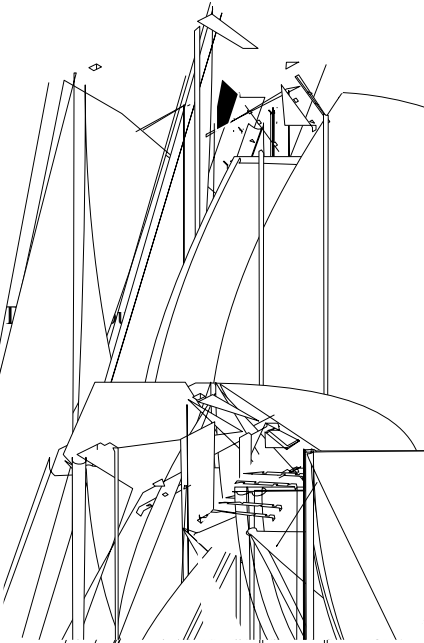

Installing the Card Holder

The KX-T7420 and KX-T7425 are equipped with a card holder with memory station card. Follow the instructions below to install the card holder to the unit.

- 1** Place the card holder edges so that they can be inserted under the slide rails on the unit.

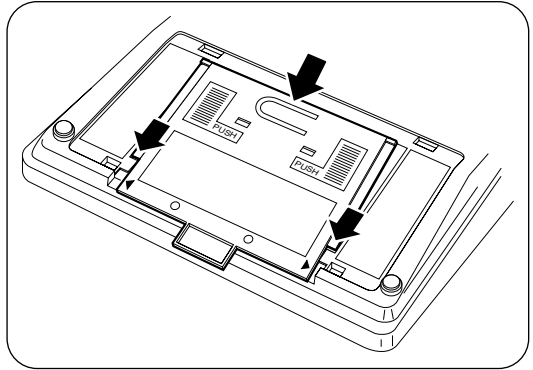

- 2** While pushing on the areas marked “PUSH”, insert the edges of the holder under the slide rails and then slide in the direction of arrow (A).

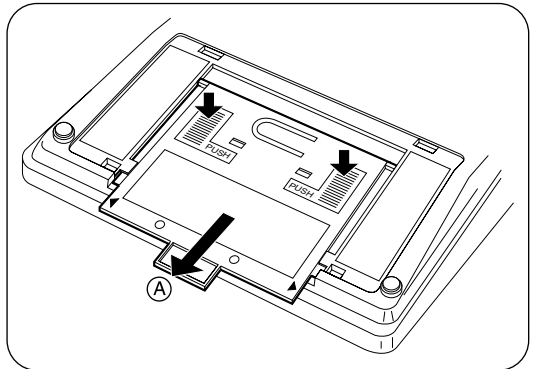





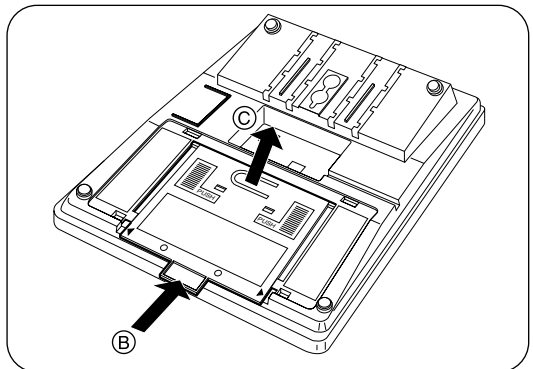



































































































Remove the card holder:

Push the card holder in the direction of arrow (B). Then, while pressing on the tab, pull the top of the holder in the direction of arrow (C).



Features List

Desired Function	Operation
Setting Absent Message	► 7 5 0 ► message no. ►
Account Code Entry	► 4 9 ► account code + # ► ► phone no.
Sending a Call Waiting tone (BSS)	<i>While hearing a busy tone</i> 2 ► Wait for an answer. ►
Forwarding a call	► ► 2 ► extension no. ► <div style="border: 1px dashed black; padding: 5px; margin: 5px;"> <p>Busy 3 ► extension no.</p> <p>No Answer 4 ► extension no.</p> <p>Busy / No Answer 5 ► extension no.</p> <p>To Outside Line 6 9 ► phone no. ► #</p> <p>Follow Me 7 ► your extension no.</p> <p>Cancel 0</p> <p>Cancel Follow Me 8 ► your extension no.</p> </div>
Holding a call	Holding ► ► To retrieve a call at the holding extension ► ►
Holding a call exclusively	Holding ► ► ► To retrieve a call on exclusive hold ► ►
Parking a call in the system	► 5 2 ► parking zone no. ►
Picking up a call	► 4 0 ►
Transferring a call	► ► ► ► <div style="display: flex; justify-content: space-around; width: 100%;"> <div>extension no. to an extension</div> <div>phone no. to an external party</div> </div> Announce. ►
Call Waiting	► 7 3 1 1 Set 7 3 1 0 Cancel ►
Three-party conference	► third party's no. ► ►
Paging	All extensions & external speaker ► 6 3 * For KX-TD816/1232 6 3 0 For KX-TD208 ► Announce.

Desired Function	Operation										
Do Not Disturb (DND)	 →  → <div style="border: 1px dashed black; padding: 5px; display: inline-block;"> <p>Forwarding to another extension  → extension no. → </p> <p>Forwarding to an operator  </p> <p>Refusing all calls  </p> <p>Cancelling </p> </div>										
Locking your extension	 → <table border="1" style="display: inline-table; vertical-align: middle;"> <tr> <td></td> <td></td> <td>lock code</td> <td>lock code</td> <td>Lock</td> </tr> <tr> <td></td> <td></td> <td>lock code</td> <td></td> <td>Unlock</td> </tr> </table> → 			lock code	lock code	Lock			lock code		Unlock
		lock code	lock code	Lock							
		lock code		Unlock							
Clearing the setting	 →    → 										
Message Waiting	<p>To leave a notification  → </p> <p>To cancel a notification  →    → extension no. → </p> <p>To call back  →  → </p> <p>To clear all notifications  →    → your extension no. → </p>										
Calling an operator	 →  → 										
Connecting an SLT in parallel	 → <table border="1" style="display: inline-table; vertical-align: middle;"> <tr> <td></td> <td></td> <td></td> <td>Set</td> </tr> <tr> <td></td> <td></td> <td></td> <td>Cancel</td> </tr> </table> → 				Set				Cancel		
			Set								
			Cancel								
Calling a pre-programmed party (Pickup Dialing)	<p>To store  →    → phone no. →  → </p> <p>To set / To cancel  → <table border="1" style="display: inline-table; vertical-align: middle;"> <tr> <td></td> <td></td> <td></td> <td>Set</td> </tr> <tr> <td></td> <td></td> <td></td> <td>Cancel</td> </tr> </table> → </p> <p>To dial </p>				Set				Cancel		
			Set								
			Cancel								
Speed dialling (Station)	<p>To set  →   → station speed dial no. → phone no. →  → </p> <p>To dial  →   → station speed dial no. → </p>										
Speed dialling (System)	 →  → system speed dial no. → 										

* For KX-TD816/1232 users, some features numbers can be changed by System Programming. Consult with your dealer for more details.

Caution

Cautions

- The apparatus is designed to be installed and operated under controlled conditions of ambient temperature and a relative humidity not greater than 60%.
- Avoid installing the apparatus in damp or humid environments, such as bathrooms or swimming pools.
- 999 or 112 can be dialled on the apparatus after accessing the CO line for the purpose of making outgoing calls to the BT emergency service.
- During dialling, this apparatus may tinkle the bells of other telephones using the same line. This is not a fault and we advise you not to call Fault Repair Service.
- If the apparatus does not operate properly, disconnect the unit from the extension line cord and then connect again.
- **Power failure transfer**
Even if the KX-T7400 series are connected to telephone line, they will not operate during a power failure.

Others:

- If there is any trouble, unplug the extension line and connect a known working phone. If the known working phone operates properly, have the defective phone repaired by one of the specified Panasonic Factory Service Centres. If the known working phone does not operate properly, check the Digital Super Hybrid System and the Internal extension wiring.
- Keep the unit away from heating appliances and electrical noise generating devices such as fluorescent lamps and motors.
- The unit should be kept free of dust, moisture and vibration, and should not be exposed to direct sunlight.
- Do not use benzine, thinner, or the like, or any abrasive powder to clean the cabinet. Wipe it with a soft cloth.
- Do not use any handset other than a Panasonic handset for model KX-T7400 series use.

- KX-T7400 series are capable of being used in conjunction with hearing aids fitted with inductive coil pick-ups. The handset should be held as for normal conversation. For operation the hearing aid should be set to it's "T" position or as directed in the operating instructions for the hearing aid.



- KX-T7400 series are designed to aid the visually handicapped to locate dial keys and buttons.
- KX-T7400 series cannot be connected to the public telecommunications network. Connecting the KX-T7400 series to the public telecommunications network is prohibited by law.

WARNING:

TO PREVENT FIRE OR SHOCK HAZARD, DO NOT EXPOSE THIS PRODUCT TO RAIN OR ANY TYPE OF MOISTURE.



MODEL No. **KX-T7400E**

Panasonic Business Systems U.K.
Panasonic House, Willoughby Road, Bracknell,
Berkshire RG12 8FP