

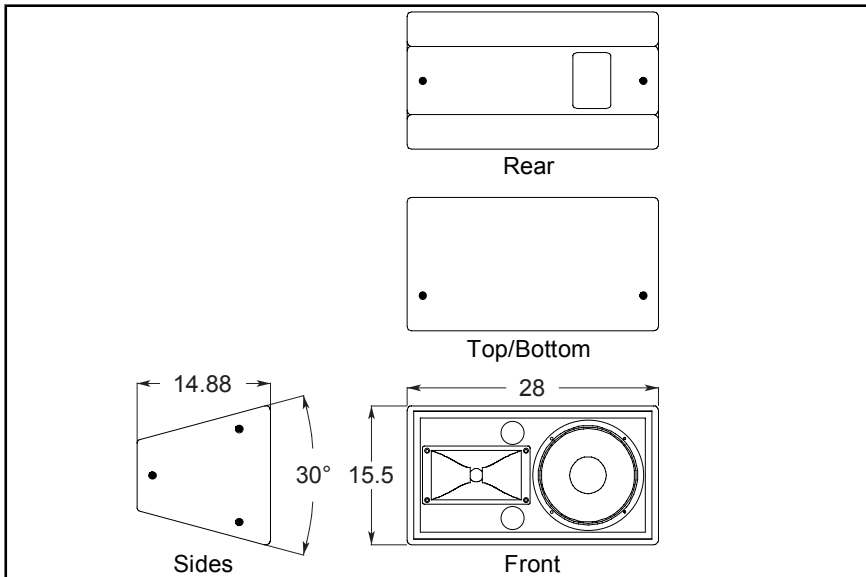

Custom Shop

Pre-Engineered
Loudspeaker Systems

CSC2264H



12" Two-Way System
Horizontal Configuration
60° x 40° Coverage Pattern
For Permanent Installation

Key Features:

- ▶ 2206H 12" VGC (Vented Gap Cooled™ LF transducer
- ▶ 2333 Optimized Aperture™ HF horn with 1.5" throat
- ▶ 2447J 4" diaphragm, 1.5" throat compression driver
- ▶ Compact trapezoidal enclosure
- ▶ DuraFlex finish - tough, weather resistant and paintable
- ▶ Tamper resistant internal Bi-amp/Passive crossover selector
- ▶ Advanced Network Topology for smooth power response and stable amplifier loading
- ▶ Versatile complement of suspension points

Specifications:

System:

Frequency Range (-10 dB):	37 Hz - 20 kHz
Frequency Response (±3 dB):	60 Hz - 18 kHz
Horizontal Coverage Angle (-6 dB):	80° averaged 500 Hz to 16 kHz
Vertical Coverage Angle (-6 dB):	70° averaged 500 Hz to 16 kHz
Directivity Factor (Q):	14 averaged 500 Hz to 16 kHz
Directivity Index (DI):	10.5 dB averaged 500 Hz to 16 kHz
Sensitivity ² :	95 dB SPL, 1W @ 1m (3.3 ft)
Calculated Maximum SPL ² :	129 dB SPL, 1W @ 1m (3.3 ft)
Nominal Impedance:	8 ohms (Passive crossover mode)
Power Rating ¹ :	600 watts IEC, 2400 watts peak

Transducers:

Low Frequency:	2206H, 300 mm (12 in) dia., 100 mm (4 in) edge wound ribbon voice coil
Nominal Impedance:	8 Ohms
Power Rating:	600 watts AES, 2400 watts peak
Sensitivity ² :	95 dB SPL, 1W @ 1m (3.3 ft)
Calculated Maximum SPL ² :	129 dB SPL, 1W @ 1m (3.3 ft)
High Frequency:	2447J; 100 mm (4") diaphragm and voicecoil dia., 76 mm (1.5") throat dia.; 2333 horn
Nominal Impedance:	16 Ohms
Input Power Rating:	75 W AES; 300 W Peak
Sensitivity ² :	112 dB, 1 W @ 1 m (3.3')
Calculated Maximum SPL:	137 dB @ 1 m (3.3')

Physical:

Enclosure:	Trapezoidal, 15° top & bottom angles, 18 mm birch plywood
Environmental Specifications:	Mil-Std 810, IPX4 per IEC 529
Suspension Attachment:	12 points, accept M10 threaded hardware
Finish:	Black DuraFlex coating (white or custom color optional)
Grille:	Black powder coated 18 gauge perforated steel grille with foam backing (white or custom color optional)
Input Connector:	2 x NL4 Neutrik Speakon connector
Dimensions (H x W x D):	394 mm x 711 mm x 378 mm (15.5 in x 28 in x 14.88 in)
Net Weight:	31.8 kg (70 lb)

The CSC2264H is a JBL Custom Shop produced adaptation of the Sound Power series SP212-6. The same transducers and switchable passive/active crossover network have been repackaged in a horizontal configuration enclosure. All of the features of the standard product have been maintained while adding installation flexibility.

The CSC2264H is available on a build-to-order basis. Contact the Custom Shop for information on availability and lead time.

¹Rating based on test signal of IEC filtered random noise with a peak-to-average ratio of 6 dB, two hours duration.
²Sensitivity is based on a swept 500 Hz to 2.5 kHz test signal for an input of 2.83V @ 8 ohms.

JBL continually engages in research related to product improvement. Some materials, production methods and design refinements are introduced into existing products without notice as a routine expression of that philosophy. For this reason, any current JBL product may differ in some respect from its published description, but will always equal or exceed the original design specifications unless otherwise stated.