

Operating manual

DVB cable receiver UFC 662sw



PREFACE

Dear customer,

this Operating Manual is intended to help you make the fullest use of the extensive range of functions offered by your new cable receiver.

We have tried to make the operating instructions as easy as possible to understand, and to keep them as concise as possible. To help you understand particular specialist terms that cannot be translated, we have added a short glossary at the end of the manual.

The power switch is an environmentally friendly feature. If you will not be using your receiver for an extended period, you should use the power switch to disconnect it from the power supply and save energy. For shorter breaks, you can use the remote control to switch the receiver to standby, which uses only a minimal amount of energy.

We wish you good reception and much pleasure using your new DVB-Cable receiver.

Your
KATHREIN team

IMPORTANT INFORMATION

The channels available on the cable network are subject to continual change. When such changes occur it is necessary to reset the channels. The information for these settings can be found on the Internet or in relevant magazines.

The information in this operating manual was correct at the time of going to print. We reserve the right however to make changes at any time and without prior notice. If new software is released for your receiver, and this affects the information in the operating manual (e.g. changes to the menus and/or functions), if we believe it necessary we will make available a new operating manual for download under "www.kathrein.de".

Please keep the original packaging in case you need to return the product at any time. If the product is not properly packed, the warranty claim is invalidated.

Make a note of the receiver's basic settings (these are set during the first installation), so you can restore them if necessary!

Before you switch off the receiver using the power switch, you must switch the remote control into stand-by mode by pressing the stand-by button. In stand-by mode, any changed data that is broadcast will be saved by the receiver. Once the receiver is in standby mode it can be fully switched off at any time at the power switch at the front of the unit. **Do not switch the receiver off at the power switch when it is in operating mode! This can lead to a loss of data and corruption of the software.**

INFORMATION ON AUDIO MPEG INC. AND S.I.SV.EL, S.P.A:

This unit makes use of legally protected technologies, which are protected by patents in the USA and also by other intellectual property rights in other countries. KATHREIN-Werke KG has obtained licences from Audio MPEG Inc. and Societa' Italiana per lo sviluppo dell'elettronica, S.I.SV.EL, S.P.A to use these technologies. These licences carry certain restrictions, which apply also to you as the customer. Accordingly this unit may only be used by the end customer for private non-commercial purposes and for the licensed content. It may not be used for commercial purposes. The use of products or processes that are sold or used with this unit is not included in this statement. The use of reverse engineering is not permitted in respect of the licensed technologies, nor is disassembly.



Manufactured under licence from Dolby Laboratories. "Dolby" and the double-D symbol are registered trademarks of Dolby Laboratories.



HDMI, the HDMI logo and High-Definition Multimedia Interface are trademarks or registered trademarks of HDMI Licensing LLC.

CONTENTS

PREFACE	2
IMPORTANT INFORMATION	3
CONTENTS	4
SAFETY INSTRUCTIONS - IMPORTANT INFORMATION	6
RECEIVER FEATURES/SCOPE OF SUPPLY	8
FEATURES	9
FEATURES	9
CONTROLS, DISPLAYS AND CONNECTIONS	10
CONNECTION AND SETUP	11
CONNECTION EXAMPLE	12
REMOTE CONTROL	14
FIRST INSTALLATION	15
OPERATING INSTRUCTIONS	19
MENU CONCEPT	19
MENU OVERVIEW	20
ALPHANUMERIC INPUTS	21
LANGUAGE SETTING - OSD	21
ON-SCREEN DISPLAYS (OSD)	22
CHANNEL MESSAGES	22
CHANNEL INFORMATION	22
SELECT AUDIO TRACK	23
ERROR REPORTING	23
CHANNEL LIST - TV/RADIO	23
EPG - ELECTRONIC PROGRAMME GUIDE	25
CALLING UP THE EPG	25
“CURRENT” VIEW	26
“PREVIEW” VIEW (PROGRAMME LISTINGS)	27
ADDITIONAL INFORMATION (i BUTTON)	28
RECORDING (TIMER)	29
ONCE-ONLY RECORDING	30
DAILY RECORDING	30
RECORD WEEKLY	31
TIMER LIST VIEW	32
VIDEOTEXT (TELETEXT)	33
EDIT TV-CHANNELLIST	34
SELECTION OF THE LIST/CHANNELS TO BE EDITED	34
EDITING LISTS/CHANNELS	35
“LAST FUNCTION” MEMORY	36
MOVE CHANNELS	36
DELETE CHANNELS	36
SKIP CHANNELS	36
LOCK CHANNELS	37
COPY CHANNELS TO THE FAVOURITES LIST	37

CONTENTS

START BLOCKSELECTION (HIGHLIGHTING SEVERAL CHANNELS)	37
EDIT TV-CHANNELLIST	38
REMOVE FROM FAVOURITES LIST	38
LOCK CHANNELS	39
RENAME FAVOURITES LIST	39
START BLOCKSELECTION (HIGHLIGHTING SEVERAL CHANNELS)	39
SEARCH CHANNELS (CHANNEL SEARCH).....	40
AUTOMATIC (CHANNEL) SEARCH.....	40
MANUAL (CHANNEL) SEARCH	42
ADVANCED CHANNEL SEARCH	43
PARENTAL CONTROL.....	45
LOCK MAINMENU	45
LOCK SET-TOP-BOX	45
DEFINE NEW PIN CODE.....	45
SETTINGS	46
FIRST INSTALLATION.....	47
REGION.....	47
TV SETTINGS (TV, VIDEO AND AUDIO).....	47
SUIT SCREEN MENU	49
DATE AND TIME	50
COMMON INTERFACE	50
SERVICE MENU	53
FACTORY RESET.....	53
CONNECTING UP THE VIDEO/PVR	54
RECORDING.....	54
USING THE FRONT PANEL/SERVICE	55
TECHNICAL APPENDIX.....	56
SCART SOCKET ASSIGNMENT	57
VHS/S-VHS SWITCHING.....	57
SHORT TECHNICAL GUIDE	58
TROUBLESHOOTING.....	60

SAFETY INSTRUCTIONS - IMPORTANT INFORMATION

These two pages contain important information about operation, installation location and connection of the unit. Read these instructions carefully before setting up the unit.



Danger!

Mains cable

Make sure that the mains cable (power supply cable) is not damaged. Units with a damaged mains cable must be disconnected from the mains (unplug it at the socket) and repaired by an electrical specialist before setup. Only use the power pack supplied (if available)!

Risk of fatal injury due to electric shock!

Cleaning

Disconnect the mains plug before cleaning the unit. Only use a dry cloth for cleaning and only clean the outer surface. Never open the casing of the unit.

Touching the parts inside the unit carries a risk of death due to electric shock!

Playing children

Make sure that children do not push any objects into the ventilation slots.

Risk of fatal injury due to electric shock!



Warning!

Earthing

The antenna system must be earthed as specified or equipotentially bonded.

EN 60728/11 and any national regulations must be complied with.

Risk of voltage surges due to lightning strikes!

Power supply voltage

Only operate the unit at the specified mains voltage (indicated on the rear of the unit or on the external power pack). The unit may only be connected to the mains and turned on once it has been connected to the antenna and to the TV set or the cable network and PC.

If the mains voltage is too high, there is a risk of fire!

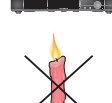

Moisture, direct sunlight, heat, naked flames

Protect the unit against moisture, dripping and splashed water (do not place any filled objects such as vases on top of the unit). Do not place the unit close to a heater or expose it to direct sunlight and do not operate it in damp locations. Only use the unit in a moderate climate, not in tropical conditions! Place no naked flames such as candles on top of the unit!

There is a risk of fire!



Batteries

If your unit was supplied with batteries (e.g. for the remote control), take care that the batteries are not exposed to excessively high temperatures, direct sunshine or fire. Exchange the batteries only with types that are identical or equivalent. Otherwise the batteries and also the remote control may be damaged. Comply also with the safety instructions stated on the batteries:

There is a risk of explosions!



Warning!



Warning!



Do not cover

Ventilation

The heat generated in this unit is adequately dissipated. However, the unit should never be installed in a cupboard or on shelves with inadequate ventilation. Never cover the cooling slots on the unit (e.g. with other equipment, magazines, tablecloths, clothing or curtains)!



SAFETY INSTRUCTIONS - IMPORTANT INFORMATION

Do not place any objects on top of the unit. Unless stated to the contrary in the "Connection and Set-Up" and "Installation" sections in the manual supplied, maintain a clearance of at least 10 cm above the unit, 2 cm to either side and 5 cm behind the unit, to allow unobstructed dissipation of the heat generated.

There is a risk of fire!



Important

Repairs

Ensure that any repairs to your unit are carried out by qualified personnel. Opening the unit and attempting to repair it yourself voids all warranty claims!

Improper work on the unit may jeopardise the electrical safety of the unit.

The manufacturer accepts no liability for accidents caused by the user opening the casing of the unit!

Connections

Incorrect wiring of the connections can lead to malfunctions or defects on the unit!

Periods of extended absence, thunderstorms, mains socket accessibility

In order to disconnect the unit from the mains completely, the mains plug must be unplugged from the wall socket! Therefore install the unit close to a mains socket and make sure that socket is accessible at all times, so that you can disconnect the unit from the mains if necessary.

If you are away for an extended period, and during thunderstorms, always switch the unit off at the mains and unplug it from the socket. This also applies to the other equipment connected to the unit. Isolation from the cable network is also recommended. Note any timer programming (receiver) and turn the unit on again promptly before the recording time.

Installation location

All electronic equipment generates heat. However, the heating of this unit lies within the permissible range. Sensitive furniture surfaces and veneers may become discoloured by the effects of constant heat over time. The feet of the unit can also cause colour changes to treated furniture surfaces. If necessary, place the unit on a suitable stable and flat base!



Electronic equipment is not domestic waste - it must be disposed of properly in accordance with directive 2002/96/EC OF THE EUROPEAN PARLIAMENT AND THE COUNCIL dated 27th January 2003 concerning used electrical and electronic appliances.

At the end of its service life, take this unit for disposal to an appropriate official collection point.

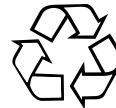

Spent batteries are special waste!

Do not throw spent batteries into your domestic waste; take them to a collection point for spent batteries!

RECEIVER FEATURES/SCOPE OF SUPPLY

The UFC 662sw receiver is suitable for the reception of digital cable TV and radio channels.

The HDMI interface offers the optimum capability for connecting the receiver to a flat-screen TV set. The built-in up-scaler processes the picture optimally for flat-screen TV sets.

Features are for instance: Kathrein EPG, guided first installation with country setting, electric audio output for Dolby Digital (AC 3), a video cinch output and Teletext with an 800-page memory.

The receiver is available in a black housing.

SCOPE OF SUPPLY

- UFC 662sw
- Remote control RC 671
- Scart cable
- 2 batteries AAA 1.5 V
- Power supply unit 230 V/12 V
- EMU 06, F adapter (F to IEC)
- Operating manual
- Safety Notes

FEATURES

FEATURES

- Reception of digital cable TV and radio channels
- HDMI output for good picture quality on your flat-screen TV set
- Up-scaler for upscaling the Pal signal (576i) to 576p, 720p and 1080i
- 4-character display
- Common Interface for one CA module ¹⁾
- Kathrein EPG with timer programming ²⁾
- Guided first installation with country setting
- Sorting by the pre-programmed channel list
- Suitable for downloading software and channel lists via a PC
- 8 favourite channel lists for TV and 8 for radio
- On-screen display (OSD) in 8 languages (D, GB, F, I, E, CZ, NL, TR)
- 14 timers; conveniently programmable using the EPG
- Language selection for multilingual broadcasts
- Electrical audio output for Dolby Digital data stream (AC 3)
- Scart socket programmable for composite colour and RGB signal output
- Cinch sockets for AV signal
- Videotext decoder with 800 page memory capacity and Videotext generation (only via Scart)
- Automatic 4:3 and 16:9 format recognition (choice of viewing format)
- Channel search
- Automatic date and time generation via DVB data stream
- Programme position sort function
- 4,000 channel memory
- Infra-red remote control
- On/off switch (disconnection from the 12 V supply) ³⁾
- Connection for external IR sensor (available as accessory)
- Compatible with the UFO[®]*compact* processing system

¹⁾ CA modules and Smartcards are not included with this product

²⁾ Displayed only if this information is broadcast by the channel provider

³⁾ The unit is not fully disconnected from the mains (see the sections "Safety Instructions - Important Instructions" and "Periods of extended absence, thunderstorms, mains socket accessibility")

CONTROLS, DISPLAYS AND CONNECTIONS

This section provides a brief description of all the controls, displays and connections.

VIEW OF FRONT PANEL (FLAP REMOVED)

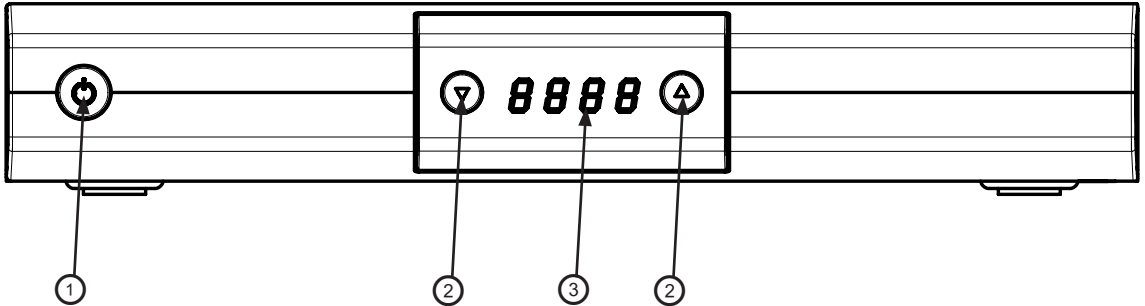

VIEW OF REAR PANEL

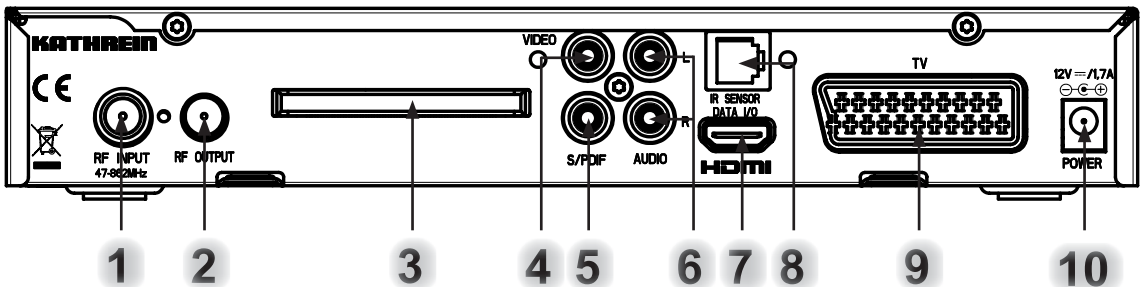

Front Panel Controls and Displays

1. On/Off switch ¹⁾
2. Channel select buttons (▼▲)
3. Display

¹⁾ The unit is not fully disconnected from the mains (see the sections "Safety Instructions - Important Instructions" and "Periods of extended absence, thunderstorms, mains socket accessibility")

²⁾ CA modules and Smartcards are not included with this product

Rear Panel Controls and Displays

1. RF(HF) input
2. RF(HF) loop-through output
3. Common Interface for one CA module for Pay-TV cards ²⁾
4. Video output (composite colour)
5. Electrical digital data stream output (SPDIF/Sony Philips Digital Interface Format) for Dolby Digital AC 3 audio
6. Audio outputs (L/R) - cinch sockets
7. HDMI Output
8. RJ 11 data interface/connection port for an external IR sensor
9. Scart socket for TV connection
10. Mains power cable

CONNECTION AND SETUP

The serial number sticker for the UFC 662sw is located on the underside of the unit.

The information printed on it includes the following:

- the exact designation (e.g. UFC 662sw)
- the part number and
- the serial number of the unit.

You do not need this information in order to operate the unit. If however, contrary to expectations, you need to make a claim under warranty and you do not have the packaging for the receiver to hand, you can find the above information about the unit on this sticker.

The following section is intended specifically for specialist dealers. You need not refer to this section unless you are carrying out the installation yourself.

The "Connection examples" section provides a sample configuration.

Do not connect the receiver to the power supply until all installation work has been properly carried out. Refer to the information in the "Safety instructions" section.

CONNECTING THE RECEIVER



Connect the RF input of the receiver to the antenna socket. For this, use a coaxial cable with a plug to with the F standard or the IEC standard (in combination with the F adapter supplied with the receiver).

If the IEC connector is not yet fitted to the cable, strip the insulation from the cable as shown in the following illustration and carefully fit the connector on to the end of the cable so that it is securely fitted.

Fitting a plug to the "F" standard

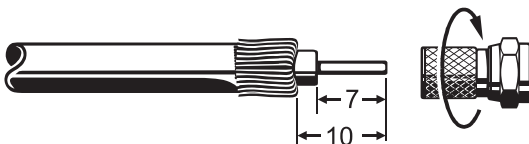

Fitting a plug to the "IEC" standard



When fitting the connector, make sure that no wires from the braid are touching the inner conductor, otherwise a short circuit will occur.

The quality of the reception signal depends on this connection!

CONNECTION AND SETUP

CONNECTION EXAMPLE

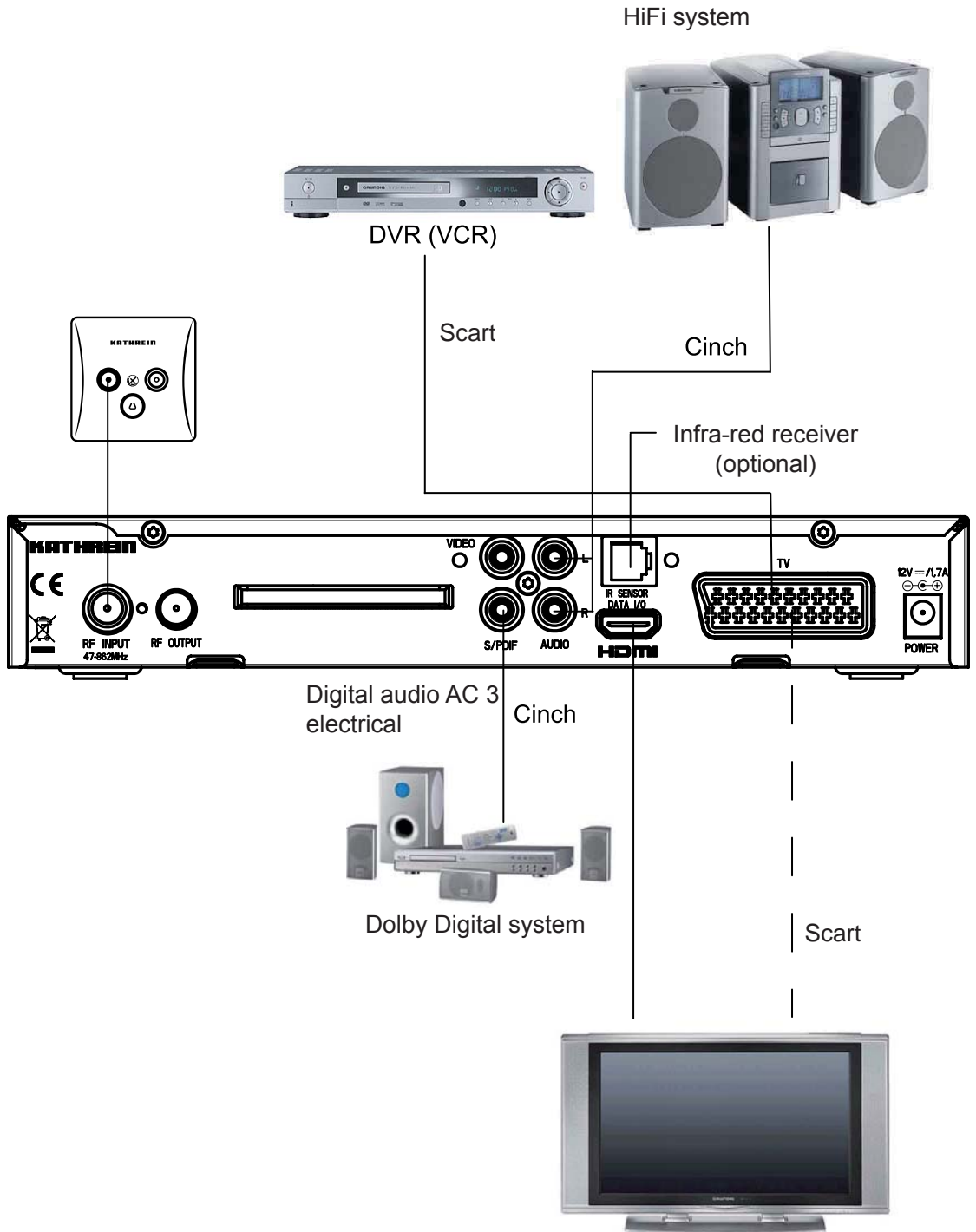

CONNECTION AND SETUP

TV AND VCR CONNECTION

Connect the cable receiver (HDMI or alternatively TV Scart socket) and the TV set using an HDMI or Scart cable (see “Connection example”). If your TV is stereo, you can receive the sound in stereo via the HDMI or Scart connection.

For system reasons, the same video signals are to be found at the TV Scart socket as at the video cinch output.

Use a Scart cable to connect the cable receiver (TV Scart socket) to the video recorder/PVR.



Connecting a video recorder/PVR to the TV Scart socket allows you only to record. It does not allow you to play back on the TV set via the receiver. If you are recording via an external video recorder/PVR, remember not to operate the receiver during recording, otherwise all the on-screen displays will appear on your recording.

AUDIO CONNECTION

If you want to play the sound on your hi-fi system, connect the audio cinch sockets to the input sockets on the hi-fi system, using an appropriate cable (see “Connection example”).

ELECTRICAL DIGITAL OUTPUT



The electric digital output is intended for the connection of a Dolby Digital system (see “Connection example”).

INSERTING BATTERIES INTO THE REMOTE CONTROL

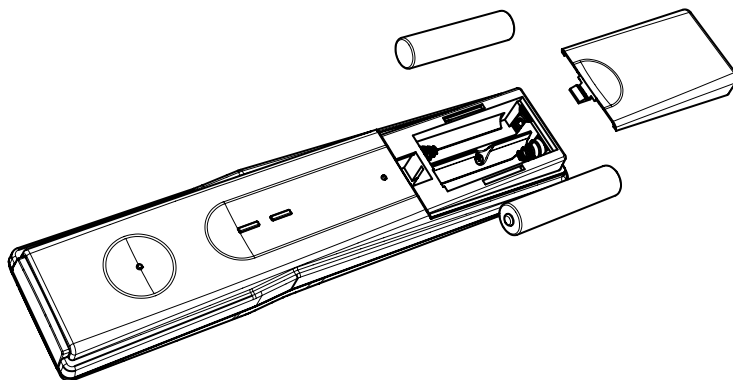
Remove the cover on the rear of the remote control. Insert the two batteries supplied into the remote control. Ensure correct polarity of the batteries; the + and – markings as indicated inside the battery compartment. Slide the cover back onto the housing until it locks in place.



REMOTE CONTROL

  wxyz

Numeric input for channels, timers etc.



Open the main menu, leave the menu and return to the TV picture

Volume



Sound on/off

 **FAV (red)**

Call up favourites selection

 **PIP (green)**

“Current” view in the EPG



Open EPG (Electronic Programme Guide)



Leave the menu step by step



Changing channel in the programme preview (EPG)

 (red)

Recording in EPG, editing in channel list



Currently not used





Power on/stand-by



Videotext (Teletext)



Access Channel Notification/Info



Channel selection up/down

 **OPT (yellow)**

Open channel options sound/subtitles selection

 **TV/R (blue)**

Switch between TV/radio



Cursor buttons



Confirm entry open channel list



Changing channel in the programme preview (EPG)



Stop recording



AV mode

The button symbols shown here can also be found in the description of the operating steps.

FIRST INSTALLATION

Before using your receiver for the first time, read the “Safety Instructions” and “Connection and Setup” sections.

The “Connection examples” section provides a sample configuration.



Do not connect the receiver to the power supply until all installation work has been properly carried out.

The guidance given in the “First Installation” section assumes that the receiver has been properly connected as per the “Safety Instructions” and “Connection and Set-Up” sections.

First switch your TV set on and select the AV channel slot. Switch on your receiver at the power switch at the front of the unit. The following display appears:

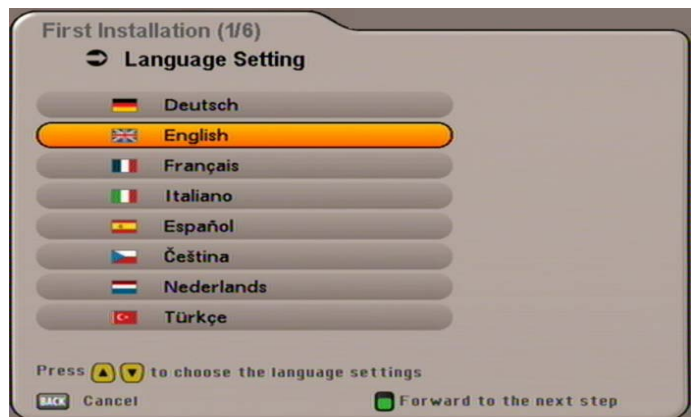

Also note the bars at the bottom of the on-screen display! These provide information on what to do next.

Select the menu language you want using the   buttons. Available options: German, English, French, Italian, Spanish, Czech, Dutch and Turkish.



Press the  (green) button to move to the next menu.

Note: *If you are unsure whether you chose the right option from a previous menu, you can go back a step at any time during the first installation process by pressing the  (red) button.*

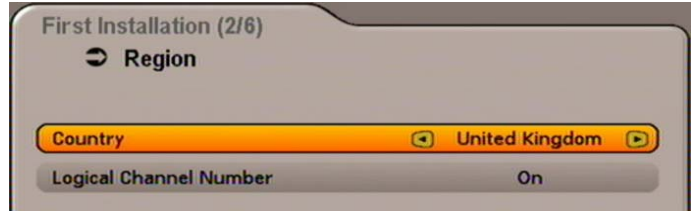

FIRST INSTALLATION

The following display appears:



Use the   buttons here to select whether you wish to use the factory pre-programmed channel sorting for the selected country. This function is however active only if you select the setting "On" for

"Logical Channel Number" in the next line. Press the   buttons to access the next line.

Use the   buttons here to select whether the channels that are found during a channel search should be sorted in accordance with the channel list saved for the previously selected country.

For example:

- "Germany" "Das Erste, ZDF, ..."
- "Austria" "ORF 1, ORF 2, ..."
- ...
- "Off" Channels are sorted in the order they are listed in the channel list

Press the  (green) button to move to the next menu.

The following display appears:

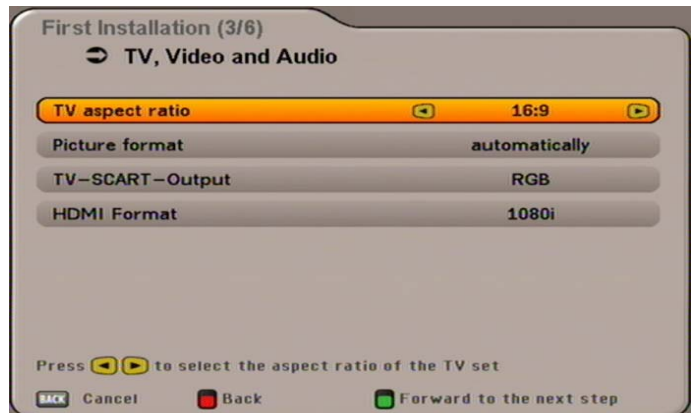

Use the  buttons here to select the settings for your TV set.

When doing this, refer to the operating instructions for your TV set!

TV aspect ratio

Here you can select the TV picture format. Either

- 4:3 or
- 16:9

FIRST INSTALLATION

Picture format

Here you can select the type of screen display, depending on the setting of your TV format:

- TV format "4:3": Pan & Scan or Letterbox
- TV format "16:9": "automatically" or "always 16:9"

TV-SCART-Output

Select the type of video signal at the TV Scart socket here. Select the signal that your TV set can process.

- FBAS - composite colour signal (colour/picture/blanking/synchronous signal) or
- RGB - Red/Green/Blue signal

HDMI Format



Here please select the format (resolution) that will be output at the HDMI socket. Select the resolution appropriate to your TV set.

Available options: "Auto" (automatic format choice), 576p, 720p or 1080i

Press the  (green) button to move to the next menu. The following display appears:





Execute Channel search

If you do not want to perform a channel search, press the  (green) button and continue with the "Date and time" section. If you do want to perform a channel search, use the   buttons to select "Yes". Since the unit is supplied with an empty channel list, we recommend you start a channel search.

If you selected "yes", you can press the  button to progress to the next selection item.



Channel Search Mode

Use the   buttons to select whether you wish to search "free and scrambled" or "only free" channels.

Press the  button to move to the next selection item.

FIRST INSTALLATION

Network Search

Use the   buttons (On/Off) to select whether a network search should be executed. If you set this to “On”, the networking of the transmission channels enables additional transmission channels that have not yet been saved to be located. They are then saved and searched for new channels in the same way as the existing channels.

If you set this to “Off”, only the factory-set frequency range will be searched.

Press the  (green) button to start the channel search, or if you set channel search to “Off” you are guided straight to the next item in the first installation process.

When the search has been completed, you will see the following message (example):





Use the  button to move to the next step of the first installation. The following display appears:

Local time offset

Use the   buttons to set the local time offset from UTC (formerly GMT) (e.g. for Great Britain +0 hours).

Use the   buttons to switch to the “Automatic clock change” field. Use

the   buttons to select whether the receiver should automatically change over to and from summer and winter time. If “On” is selected, the receiver automatically sets itself to the

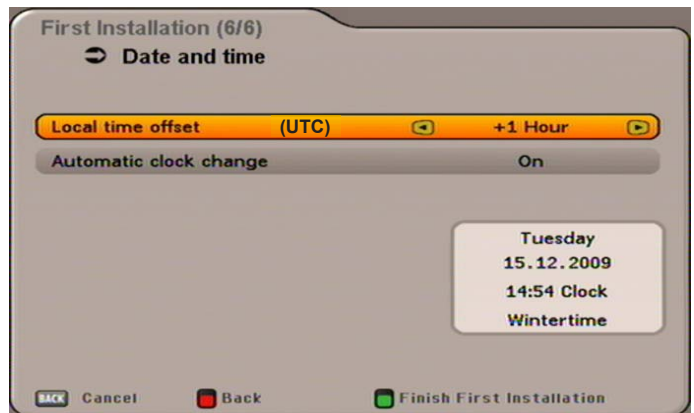

right time. If “Off” is selected, the field for manual selection of summer and winter time is displayed below.

Press the   buttons to perform the setting.

Press the  (green) button to close First Installation and return to the TV picture.

OPERATING INSTRUCTIONS

MENU CONCEPT

The structure of the menu concept is based on logical operating sequences. The programme showing on the current selected channel always appears in the top right-hand corner of the screen.

You will find detailed descriptions of the selected menu items in the relevant sections of the operating manual!

Note: *The selected menus, sub-menus and positions, as well as the parameters to be set, are each highlighted in colour. The menus are self-explanatory.*

Note the bar at the bottom of the on-screen display! This provides information on what to do next.



Press the **MENU** button to open the main menu, and use the **▲** **▼** buttons to select the sub-menus.

Press the **OK** button to access the sub-menus. Use the **▲** **▼** buttons to select the sub-menu options.

The settings under the various options are made either by pressing the **◀** **▶** buttons or using the numeric pad. You can exit the main menu and sub-menus and the various options step-by-step by pressing

the **BACK** button (the settings/changes you made are saved). Press **MENU** to return directly from one of the menus to the TV picture (the settings/changes you made are saved).

OPERATING INSTRUCTIONS

MENU OVERVIEW

Mainmenu

Open the menu by pressing the  button



OPERATING INSTRUCTIONS

ALPHANUMERIC INPUTS

Use the displayed keypad (see figure to the right) for entry of favourites names or search expressions by selecting numerals for the desired letters/digits. You can write

with upper or lower case letters ( button). Use the numeric pad to select the desired character. About two seconds after selection of the character, the cursor moves







automatically to the next position. The  button allows you to delete your entry character by character.



When you have selected all the characters, press the  button to “save” your entry and start a search to find the desired expression.

LANGUAGE SETTING - OSD

The language for the on-screen display is set as follows:

 →   → Language setting →  →   → English → 

Available options: German, English, Italian, French, Dutch, Spanish, Czech and Turkish.

After you have performed the settings, press the  or  button to exit the main menu. You will then return to the TV picture.

ON-SCREEN DISPLAYS (OSD)

CHANNEL MESSAGES

TV CHANNEL MESSAGES

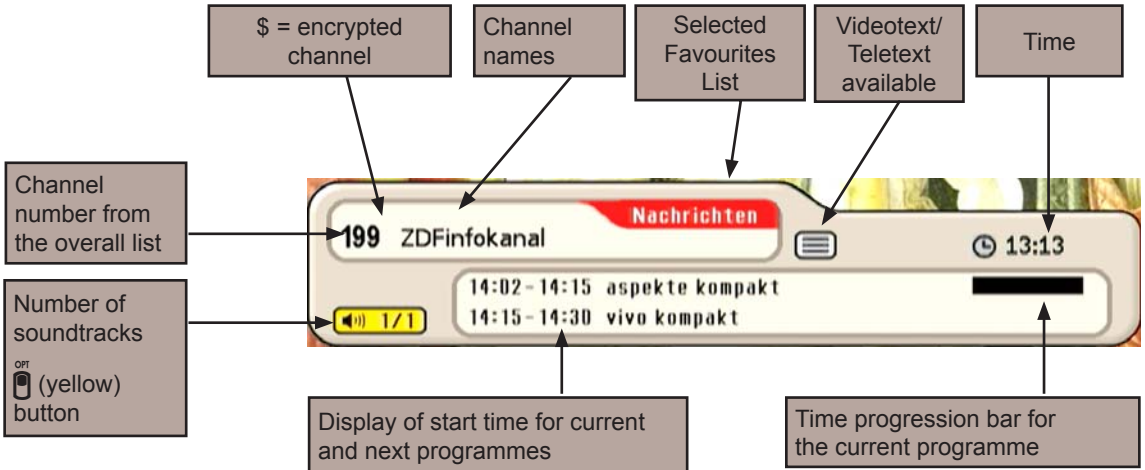

Channel information is shown for a few seconds each time the channel is changed (this can be changed under “Settings”, “Suit screen menu”).

RADIO CHANNEL MESSAGES

The information for the current radio channel has the same layout.

CHANNEL INFORMATION

Press **i** twice to view information on the current channel, if transmitted by the channel provider.

Use the **▲** **▼** buttons to scroll through the

pages. By pressing the **◀** **▶** buttons you can obtain information on the programmes to

come on the current channel. Press the **i**

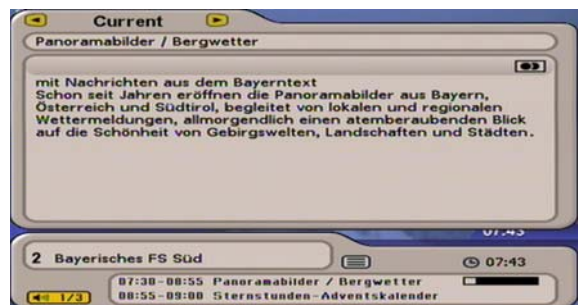

or **BACK** button to exit the display.





ON-SCREEN DISPLAYS (OSD)

SELECT AUDIO TRACK

Press the  (yellow) button once to view further soundtrack selection options, if these are transmitted

by the channel provider. Use the   buttons to scroll through the available selection options.

Press the  (yellow) button again, or press the  button to exit this display again.



ERROR REPORTING

“Weak or no signal” indicates that an error has occurred in the reception system or in the receiver settings.

Check the cable connection at the receiver and at the antenna socket. If you have changed settings, compare them against the basic settings (provided you had made a note of them as suggested).

CHANNEL LIST - TV/RADIO

Press the  button to access the channel list.

Also note the bars at the bottom of the on-screen display! These provide information on what to do next.



When you open this list the channel list selection/sort order is displayed from where you selected the last channel.









At the top left you will see the selected channel list (TV Channel or Radio Channel) displayed.

Press the  (blue) button to switch between the TV and radio channel lists.



ON-SCREEN DISPLAYS (OSD)

Underneath you can see the channel list with the sort order you selected. The channel list can display channels sorted by various selection and sorting criteria.

Selection and sorting options:

- Press the  (red) button to open the favourites list selection. The   buttons allow you to scroll through the existing favourites lists
- Press the  (green) button to return to the channel list. Use the   buttons to choose between the channel list (display all channels) and the list of “New channels” (provided by channel search).
- Press the  (yellow) button to see an alphabetic listing. This list displays all the channels sorted alphabetically, or the ones beginning with the selected initial letter. Use the   buttons to make the selection.





Search function:

- Press the  button to start the search. The numeric pad buttons allow you to input the desired search expression for the channel that is sought (see also “Operating instructions”, “Alphanumeric input”). Press the  button to start the search.

Press  to view the following items of information on a channel (see screenshot on the right as an example):

- Signal-Strength
- Signal-Quality
- Provider
- Frequency (MHz)
- Symbol Rate
- QAM mode



The cursor buttons () are used to navigate within the respective channel list view to select the desired channel. The selection of the desired channel is confirmed by pressing the  button. You will now hear and see the currently selected channel in the small window at the top right. To exit the channel list and return to the TV picture, press the  button again, or press the  button.

EPG - ELECTRONIC PROGRAMME GUIDE

CALLING UP THE EPG



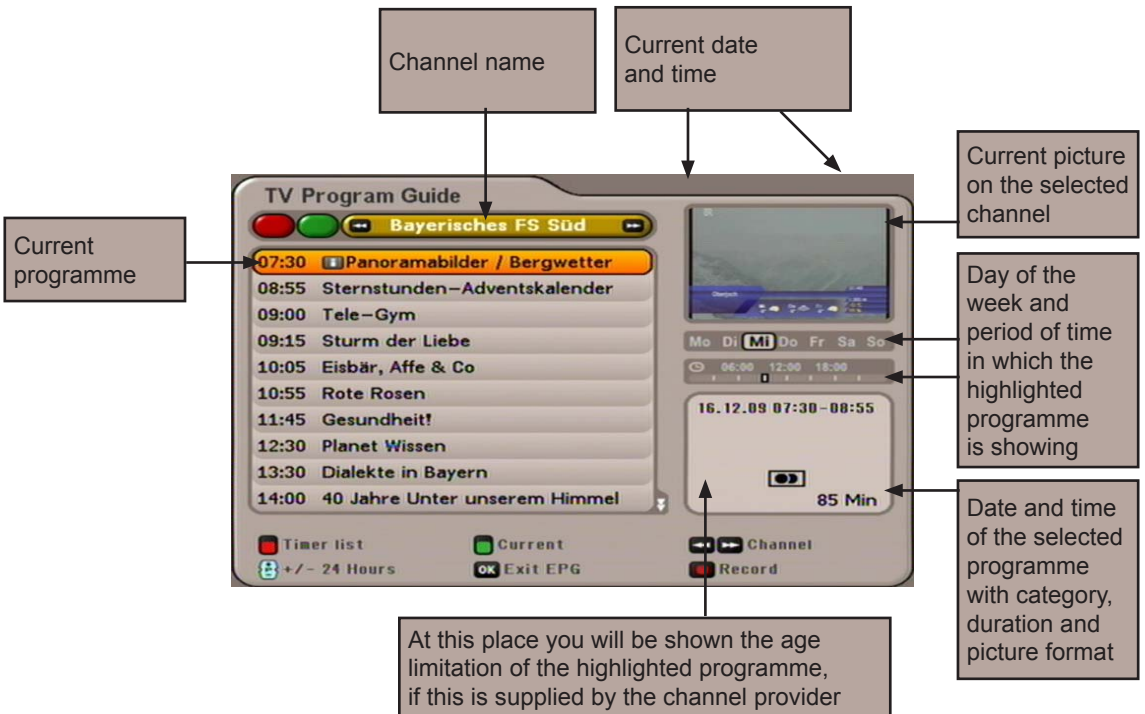







The EPG is opened by pressing the  button. Each time the EPG is opened, you will automatically be shown the "Preview" view, irrespective of which view you were shown the last time you left the EPG. The following display appears (example):







Note: *If you selected a favourites list before opening the EPG, you will see in the EPG only the data for the channels that are included in this favourites list.*

EPG - ELECTRONIC PROGRAMME GUIDE

Selection options:

-  (red) button Open the Timer list (display of all pre-programmed recordings)
-  (yellow) button Calling up the "Preview" view
-  (green) button Calling up the "Current" View
-  button Changing the channel from within the "EPG" view
-  button Next programme in the "Current" view
-  button (P+) jump forwards 24 hours in the EPG, (P-) jump backwards 24 hours
-  button Select the currently selected channel in all views. Pressing the  or the  button again closes the EPG and the selected channel is shown again on the TV screen
-  (red dot) button Add a programme to the recording settings
-  button Shows any further information on the selected programme.

Navigation within each view is always performed using the cursor buttons (). The  buttons allow you to select individual channels/programmes, and the  buttons allow you to scroll from page to page of the currently selected list.

Pressing the  or  button exits the EPG and returns to the TV picture.





You will see information on the current or next following programmes in the EPG only if it is supplied by the channel provider.



"CURRENT" VIEW

The "Current" view can be called up at any time in EPG by pressing the  (green) button.

In the "Current" view you can see all channels displayed in the order of the overall channel list. Provided that EPG data has been supplied by the channel provider, the receiver shows for each channel the current programme being shown, with start time, finish time, and progression bar.

You can use the cursor buttons () to select the desired programme and if available you can use the  button to call up further information on the desired programme.

EPG - ELECTRONIC PROGRAMME GUIDE

Pressing the  button displays the next programme ("Next" view); (pressing the  button returns you to the "Current" view.

If you wish to view the programme currently being shown on a channel, you need not exit the EPG, just select the desired channel. At the top right of the screen you will see the current TV picture for the selected channel.



"PREVIEW" VIEW (PROGRAMME LISTINGS)



The "Preview" view (programme listings) can be called up at any time in EPG by pressing the  (yellow) button.

Also note the bars at the bottom of the on-screen display! These provide information on what to do next.



In the "Preview" view you will see all the programmes that will be shown in the previous "Current" list of selected channels. Provided that EPG data has been supplied by the channel provider, the receiver displays the programmes that will be shown on the selected channel for several days in advance.

You can use the cursor buttons () to select the desired programme and, if available, you can use the  button to open further information on the desired programme.

Using the   buttons you can scroll through the channels in their sequence in the overall channel list. You remain however within the "Preview" view at all times.

The  button allows you to scroll backwards and forwards a day at a time.

Using the  (red dot) button you can copy the selected programme to the recording settings (see "Recording" section).

EPG - ELECTRONIC PROGRAMME GUIDE

ADDITIONAL INFORMATION (i BUTTON)

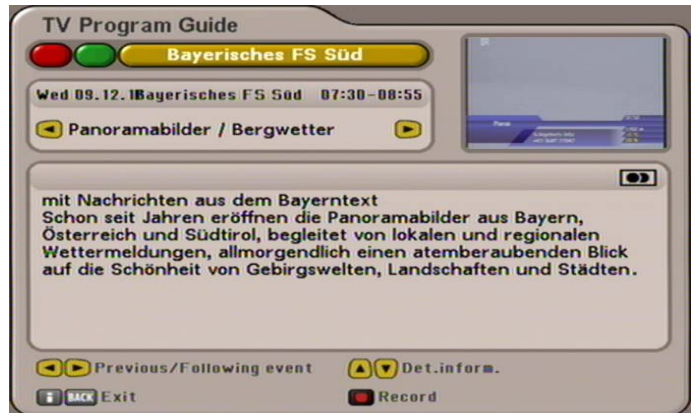

The additional information can always be called up by

pressing the  button whenever the “i symbol” appears in front of the programme name (see screenshot on the right). First however the channel must be selected. The following display appears (example):





The additional information available for a programme is displayed in its own window. By pressing the

 button, if available, you can open further additional information on the selected programme.



The   buttons enable you to display the additional information for the preceding or following programmes in the order of the previously selected list (see header). This feature always assumes that the data has been supplied by the channel provider.

Using the  (red dot) button you can copy the selected programme to the recording settings (see „Recording“ section).

Press the  or  button to drop the additional information.

EPG - ELECTRONIC PROGRAMME GUIDE

RECORDING (TIMER)

The  (red dot) button allows you to set up a programme at any time for recording on an external recorder. The programme to be recorded can be selected in any of the EPG views, provided the  (red dot) button appears at the bottom of the screen display.



If the programme appears on the EPG:

Select the desired programme and press the  (red dot) button. The following display appears (see example picture below):

If the programme does not appear on the EPG:

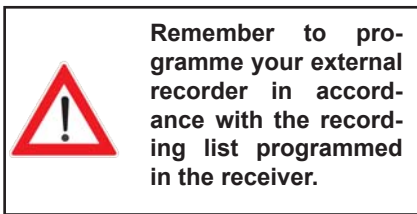
Select any programme on the channel on which the desired programme is to be transmitted at a later time and press the  (red dot) button (starting and finishing times together with the recording date must be input manually).



Use the   buttons to select the desired recording mode. The following recording mode options are available:



- **Once:** The recording will be performed once
- **Daily:** The recording will be performed daily at a time specified by you
- **Weekly:** The recording will be performed once a week on the same day and at the same time





Use the cursor buttons () to select the further items and use the keypad to complete the settings.





When all settings have been made, press the  button to save the recording settings. You can view the scheduled recordings in the Timer List of the EPG (see "Timer list" section).





EPG - ELECTRONIC PROGRAMME GUIDE

ONCE-ONLY RECORDING

Use the   buttons to select the recording mode “once” (see screenshot “Recording (timer)” section).

Use the   buttons to switch to the “Date” field and use the   buttons to select the desired recording day.

Then use the   buttons to switch to the selection field “Start” and use the   buttons or the number keys to select the desired recording start time.

Use the   buttons to switch to the selection field “Duration” and use the   buttons or the numeric pad buttons to select the desired recording length.



When all settings have been made, press the  button to save the recording settings. You can view the recording in the recording list view of the EPG (see item “Timer list”).



DAILY RECORDING

Use the   buttons to select the recording mode “daily” (see screenshot below).

Then use the   buttons to switch to the selection field “Start”

and use the   buttons or the number keys to select the desired

recording start time. Use the   buttons to switch to the selection field

“Duration” and use the   buttons

or the numeric pad buttons to select the desired recording length.

When all settings have been made, press the  button to save the recording settings. You can view the recording in the Plan recording view of the EPG (see item “Timer list”).



EPG - ELECTRONIC PROGRAMME GUIDE





RECORD WEEKLY







Remember that the day of the week for the desired programme is loaded in the recording list and you can make no further manual corrections to it! Therefore

before pressing the  (red dot) button, select the programme on the day of the week that in future you will wish to make the weekly recording.

Use the   buttons to select the recording mode “weekly” (see screenshot below).

Then use the   buttons to switch to the selection field “Start” and use the   buttons or the number keys to select the desired recording start time.

Use the   buttons to switch to the selection field “Duration” and use the   buttons or the numeric pad buttons to select the desired recording length.



When all settings have been made, press the  button to save the recording settings. You can view the recording in the Plan recording view of the EPG (see item “Timer list”).



EPG - ELECTRONIC PROGRAMME GUIDE

TIMER LIST VIEW

The Timer list view can be called up at any time in EPG by pressing the  (red) button.



The Timer list view shows you all the recordings that are scheduled.

The   buttons allow the recordings to be sorted into “once” or “repeated” recordings.

The cursor buttons () allow you to select a recording.

The  (red dot) button allows you to delete a recording that had been scheduled.

VIDEOTEXT (TELETEXT)







This symbol  in the channel information shows you whether Teletext is available for the selected channel.

When you press the  button, the receiver processes the Videotext/Teletext service data for your TV set to display, even when the signal is encrypted.







When the search is finished, the Teletext being broadcast by the relevant encrypted provider appears:

You have several options for opening the desired pages:

- Input with numeric keypad
- Scroll backwards and forwards using the   buttons
- Selection using the options indicated by the coloured buttons  (red),  (green),  (yellow) and  (blue) listed across the bottom of the screen

Press  or  to exit Teletext.

EDIT TV-CHANNELLIST

Select the “Edit TV-Channellist” menu using the  button, the   buttons on the main menu and .



Also note the bars at the bottom of the on-screen display! These provide information on what to do next.





When the menu is opened, the standard setting is for the receiver to show the channel list with all channels available (overall list).







SELECTION OF THE LIST/CHANNELS TO BE EDITED

Press the  (blue) button to switch between the TV and radio channel lists. Radio channels are edited in the same way as TV channels.

Editing favourite lists is explained as a separate item.

Selection options:

-  (blue) button Switch between radio and TV channels
-  (green) button Calling up the channel lists
-  (yellow) button Open the channel lists, sorted alphabetically
-  button Search for a specific channel (input the search expression using the numeric pad on the remote control, see also the sections “Operating Instructions” “Alphanumeric Entries”)

The channel list chosen is generally that sorted by categories (overall, favourites and alphabetic) using the   buttons (the standard list called up is the “Overall” channel list). Selection of channels in the list is performed using the cursor buttons . The   buttons allow you to select individual channels, and the   buttons allow you to scroll from page to page of the currently selected list.

EDIT TV-CHANNELLIST



EDITING LISTS/CHANNELS



When you have selected the channel or channel list to be edited, press the  (red dot) button to open the edit menu. You have the following edit options:



- **Move:**
Channel can be moved within the current list to another channel slot
- **Delete:**
Delete the channel from the current list
- **Skip:**
Channel will be skipped when zapping through the channels
- **Lock:**
Channel can be viewed only by entering a PIN
- **To Favorite:**
A channel can be assigned to any Favourites List
- **Start Blockselection:**
Several channels can be selected at the same time and edited together















As soon as you exit the menu under which you made the edit changes, you will be asked if you wish to save the changes. Use the   buttons to select either "Yes, save changes" or "No, don't save changes". Confirm your selection with the  button.

EDIT TV-CHANNELLIST







“LAST FUNCTION” MEMORY

The last editing action performed is saved on the  button, so by pressing the  button you can apply the last selection to other channels without having to open the edit menu again. As soon as you leave the current display, this option is cleared and becomes available again only after the edit menu has been opened and an action selected.

MOVE CHANNELS

Use the   buttons to select the channel to be moved from the current channel list (use the  (green) button to switch to the overall list, use the  (yellow) button to switch to the alphabetically sorted list). Press the  button to open the edit menu and use the   buttons to select the “Move” function. Confirm the command by pressing the  button. The channel you previously selected will now be shown inset slightly from the left. Now use the cursor buttons (   ) or the number buttons to select the new desired position for the channel, and confirm the new channel slot by pressing the  button.

DELETE CHANNELS







Use the   buttons to select the channel to be deleted from the channel list you have selected. Press the  button to open the edit menu and use the   buttons to select the “Delete” function. Confirm the command by pressing the  button.



A deleted channel can be recovered only by performing another channel search (see section “Channel Search”)!

The channel you previously selected will be deleted (from the favourite lists also!).



SKIP CHANNELS

Use the   buttons to select the channel to be skipped from the current channel list. Press the  button to open the edit menu and use the   buttons to select the “Skip” function. Confirm the command by pressing the  button.

The channel you previously selected is now shown in grey text. When zapping the channels this channel will in future be skipped and no longer shown in the channel list (called up using the  button). This function can be restored again using the edit menu (select: “Unskip”).

EDIT TV-CHANNELLIST

LOCK CHANNELS

Use the   buttons to select the channel to be locked from the channel list you have selected.





Press the  button to open the edit menu and use the   buttons to select the “Lock” function.



Confirm the command by pressing the  button. You are now prompted to enter the PIN code (factory default setting: 0000).

The channel you previously selected is now shown with a padlock to its right. In future this channel can be viewed only by entering the four-digit PIN code.

This function can be restored again using the edit menu (select: “Unlock”).

COPY CHANNELS TO THE FAVOURITES LIST



Use the   buttons to select the channel to be copied from the current channel list. Press the  button to open the edit menu and use the   buttons to select the “To Favorite” function.



Use the   buttons to select the favourites list to which the channel is to be copied. The channel remains in the overall channels list. Confirm the command by pressing the  button.



The channel you previously selected is now shown with an “F” and a yellow field in the channel list. The “F” shows that it is a favourite channel; the black dot in the yellow field shows in which of the eight favourites lists the channel can be found.



See the item “Edit favourite lists” for information on how to delete a channel from a favourite list.

START BLOCKSELECTION (HIGHLIGHTING SEVERAL CHANNELS)

Use the   buttons to select the channel from which you want to highlight further channels. You can only select channels that are listed in succession in the channel list you have selected.

Press the  button to open the edit menu and use the   buttons to select the “Start

Blockselection” function. Confirm with the  button. Use the   buttons to highlight the desired channels, starting from the previously highlighted channel and working upwards or downwards. The highlighted channels will be highlighted in yellow and marked with a tick on the left. When you have

highlighted the channels that you wish to select, press the  button to open the edit menu once again and use the   buttons to select the desired function (“Move”, “Delete”, “Skip”, “Lock” or “To Favorite”).





Confirm with the  button.

The selected function can now be used in the same way as described for the respective items in this section for a single channel.

EDIT TV-CHANNELLIST







EDIT FAVOURITES LISTS



When you have selected the favourites list to be edited (called up using the  (red) button and selected using the   buttons), press the  (red dot) button to open the edit menu. You have the following edit options:

- **Remove from favourites list:**
The channel will be removed from the favourites list
- **Lock:**
Channel can be viewed only by entering a PIN
- **Rename favourites list:**
The favourites list can be renamed
- **Start Blockselection:**
Several channels can be selected at the same time and edited together



REMOVE FROM FAVOURITES LIST

Use the   buttons to select the channel to be removed from the favourites list you have selected. Press the  button to open the edit menu and use the   buttons to select the "Remove from favourites list" function. Confirm the command by pressing the  button.

The channel you previously selected is now removed from the favourites list (but not deleted from the overall channel list).

EDIT TV-CHANNELLIST

LOCK CHANNELS

Use the   buttons to select the channel to be blocked in the favourites list you have selected.

Press the  button to open the edit menu and use the   buttons to select the “Lock” function.





Confirm the command by pressing the  button. You are now prompted to enter the PIN code (factory default setting: 0000).

The channel you previously selected is now shown with a padlock to its right. In future this channel can be viewed only by entering the four-digit PIN code.

The channel is also locked on all other channel lists. You need not additionally lock the channel in the other channel lists.



This function can be restored again using the edit menu (select: “Unlock”).

RENAME FAVOURITES LIST



Use the   buttons to select the favourites list to be renamed. Press the  button to open the edit menu and use the   buttons to select the “Rename favourites list” function.

Confirm the command by pressing the  button. A keypad will now be displayed with which you can enter the desired name alphanumerically using the numeric pad on the remote control. See also the section “Operating Instructions”, “Alphanumeric Entries”)



START BLOCKSELECTION (HIGHLIGHTING SEVERAL CHANNELS)

Use the   buttons to select the channel starting from which you want to highlight further channels. You can only select channels that are listed in succession in your selected favourite list. Press the

 button to open the edit menu and use the   buttons to select the “Start Blockselection”

function. Confirm with the  button. Now use the   buttons to highlight the desired channels, starting from the previously highlighted channel and working upwards or downwards. The highlighted channels will be highlighted in yellow and marked with a tick on the left. When you have highlighted

the channels that you wish to select, press the  button to open the edit menu once again and use

the   buttons to select the desired function (“Remove from favourites list”, or “Unlock”). Confirm

with the  button.

The selected function can now be used in the same way as described for the respective items in this section for a single channel.

SEARCH CHANNELS (CHANNEL SEARCH)

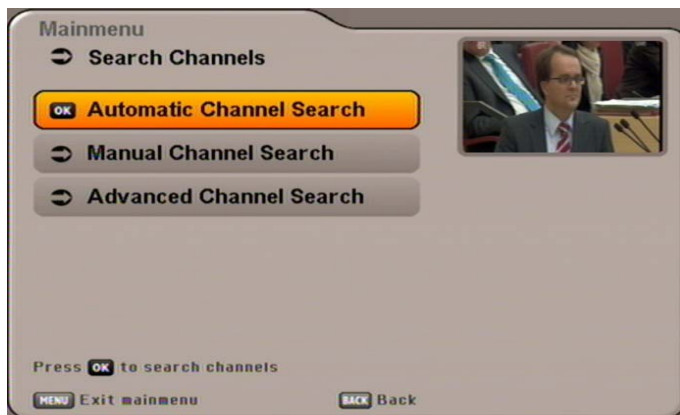

Select the "Search Channels" menu using the  button, the   buttons in the main menu and .

Also note the bars at the bottom of the on-screen display! These provide information on what to do next.



You have three options for a channel search.

- Automatic Channel Search - all transmission channels will be searched
- Manual Channel Search - only the selected transmission range will be searched
- Advanced Channel Search - search for a specific channel (you must input/select the search parameters yourself)

Use the   buttons to select the desired type of search and confirm your selection using the  button.





After a search (of whatever type) the receiver shows all newly found channels in the channel list under the rubric "New Channels". You will find this rubric in the channel list

by pressing the  (green) button (press the   buttons to make the selection).



AUTOMATIC (CHANNEL) SEARCH







SEARCH CHANNELS (CHANNEL SEARCH)

The   buttons allow you to select different sets of parameters for the search.

Channel Search Mode

Use the   buttons to select whether you wish to search “free and scrambled” or “only free” channels.

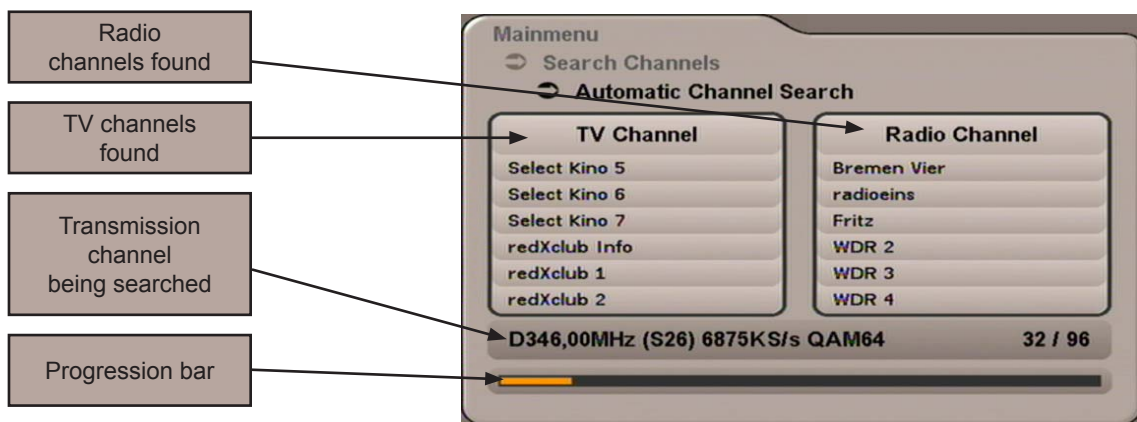

Use the   buttons to select “Start Search” and press the  button to start searching. You can cancel the search at any time by pressing the  button. During the search you will see the following message (example):





Newly found channels are identified with the designation “New” after the channel name. After completion of the search, you will see the following message (example):



Press the  button. You will be asked whether you wish to save the changes

or not. Use the   buttons to make the selection and confirm with

the  button. If you select “Yes, save changes”, the newly found channels will be added to the end of the channel list. Then press the  button to exit the menu. The channel list is called up on the TV screen by pressing the  button (see also section “On-Screen Displays” “Channel List TV/Radio”).

SEARCH CHANNELS (CHANNEL SEARCH)

MANUAL (CHANNEL) SEARCH

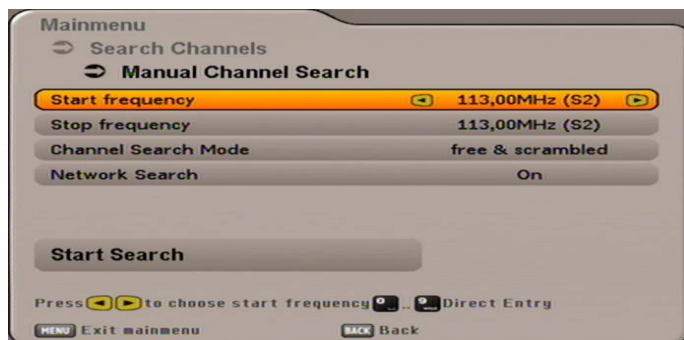

The buttons allow you to select different sets of parameters for the search.

Start frequency

Use the buttons to select the start frequency for the search.

Stop frequency

Use the buttons to select the end frequency for the search.

Channel Search Mode

Use the buttons to select whether you wish to search “free and scrambled” or “only free” channels.

Network Search

Use the buttons (On/Off) to select whether a network search should be performed. If you set this to “On”, the networking of the transmission channels enables additional transmission channels that have not yet been saved to be located. They are then saved and searched for new channels in the same way as the existing channels.

If you set this to “Off”, only the factory-set frequency range will be searched.

When you have made your settings, use the buttons to select “Start Search” and press the button to start searching. You can cancel the search at any time by pressing the button.

During the search you will see a display that shows you the progress of the search and the channels found so far. Newly found channels are identified with the designation “New” after the channel name.

SEARCH CHANNELS (CHANNEL SEARCH)

After completion of the search, you will see the following message (example):



Press the **OK** button. You will be asked whether you wish to save the changes or not. Selection is performed using the **▲▼** buttons and is confirmed by pressing the **OK** button. If you select "Yes, save changes", the newly found channels will be added to the end of the channel list. Then press the **BACK** button to exit the menu. The channel list is called up on to the TV screen by pressing the **OK** button (see also section "On-Screen Displays" "Channel List TV/Radio").

ADVANCED CHANNEL SEARCH



The **▲▼** buttons allow you to select different sets of parameters for the search.

Frequency

Using the **◀▶** buttons, select the frequency to be searched.

Symbol rate



Use the **◀▶** button or the number keys to enter the applicable symbol rate.

QAM mode



Use the **◀▶** buttons to enter the respective QAM mode.

SEARCH CHANNELS (CHANNEL SEARCH)





Channel Search Mode

Use the   buttons to select whether you wish to search “free and scrambled” or “only free” channels.

Network Search

Use the   buttons (On/Off) to select whether a network search should be performed. If you set this to “On”, the networking of the transmission channels enables additional transmission channels that have not yet been saved to be located. They are then saved and searched for new channels in the same way as the existing channels.







If you set this to “Off”, only the factory-set frequency range will be searched.

When you have made your settings, use the   buttons to select “Start Search” and press the  button to start searching. You can cancel the search at any time by pressing the  button.





During the search you will see a display that shows you the progress of the search.

After completion of the search, you will see the following message (example):





Press the  button. You will be asked whether you wish to save the changes or not. Selection is performed using the   buttons and is confirmed by pressing the  button. If you select “Yes, save changes”, the newly found channels will be added to the end of the channel list. Then press the  button to exit the menu. The channel list is called up on the TV screen by pressing the  button (see also section “On-Screen Displays” “Channel List TV/Radio”).

PARENTAL CONTROL

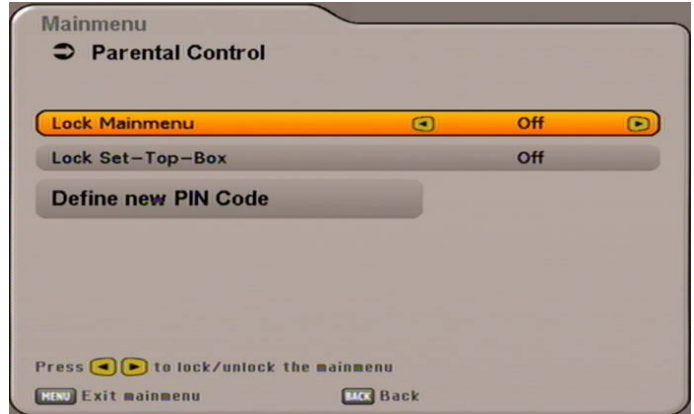

Select the "Parental Control" menu using the menu button , the   buttons on the main menu and . You are now prompted to enter the PIN code (factory default setting: 0000).

After entering the PIN using the number pad you are shown the following display:





Select the parameters to be changed using the   buttons.

LOCK MAINMENU

Use the   buttons (On/Off) to select whether the main menu should be locked. If the menu is locked, changes can be made only by entering the four-digit PIN code.

LOCK SET-TOP-BOX

Use the   buttons (On/Off) to select whether the receiver should be locked. If the receiver is locked, it can be operated only by entering the four-digit PIN code after it has been switched on (factory setting: 0000).

DEFINE NEW PIN CODE

Press  to replace the old PIN with a new one. Enter the new (four-digit) PIN. For security you must repeat the new PIN code once again.

Confirm the change of PIN code by pressing the  button.



Keep your PIN code in a safe place, so that you always have access to your channels should you ever forget it.

If you have forgotten your PIN code, you must contact your dealer, who will be able to unlock your receiver for you.

Press the  button to exit the menu again.

SETTINGS

The selected menus, sub-menus and items, as well as the parameters to be set, are each marked in colour. The menus are largely self-explanatory.

Note the bar at the bottom of the on-screen display. These provide information on what to do next.



Select the "Settings" menu using the **MENU** button, the **▲▼** buttons in the main menu and **OK**.

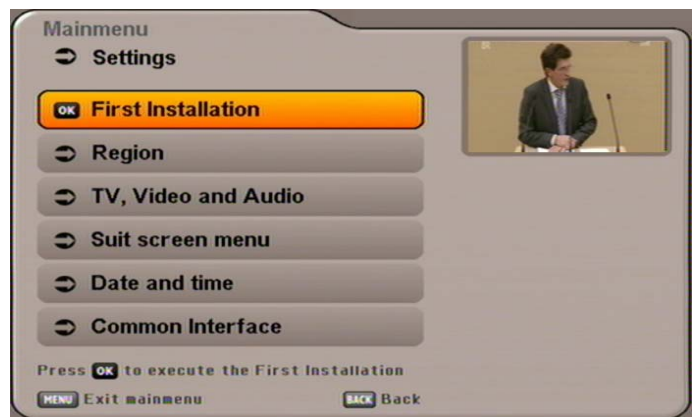

The individual menus are selected using the **▲▼** buttons and called up using the **OK** button.

Use the **▲▼** buttons to select the further options. If there is another sub-menu layer, press the **OK** button to open it. If there are no more sub-menus, make the settings using the  or the number pad.

Press the **BACK** button to save your settings and return to the previous menu. Press the **MENU** button to return directly to the TV picture, the changes will also be saved.



SETTINGS

FIRST INSTALLATION

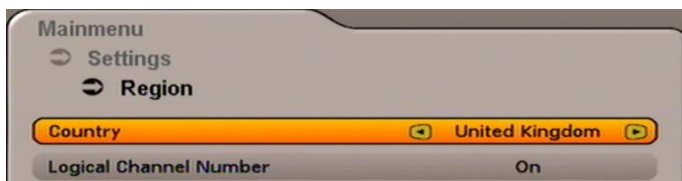

See “First Installation” section.

REGION



Use the   buttons here to select whether you wish to use the factory pre-programmed channel listing for the selected country. This function is however active only if you select the setting

“On” for “Logical Channel Number” in the next line. Press the   buttons to access the next line.

Use the   buttons here to select whether the channels that are found during a channel search should be sorted in accordance with the channel list saved for the previously selected country.

For example:



- “Germany” “Das Erste, ZDF, ...”
- “Austria” “ORF 1, ORF 2, ...”
- ...
- “Off” Channels are sorted in the order they are listed in the channel list

Press the  button to exit the menu again.

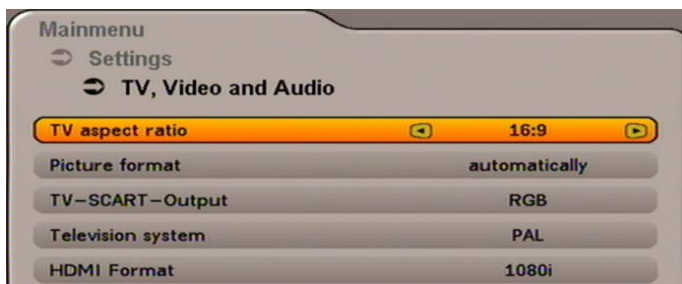
TV SETTINGS (TV, VIDEO AND AUDIO)





TV ASPECT RATIO

Here you can use the   buttons to select the picture format for your TV. Either

- 4:3 or
- 16:9 format.



SETTINGS

PICTURE FORMAT

Here you can use the   buttons to select the type of screen display, depending on the setting of your TV format:

- TV format "4:3": Pan & Scan or Letterbox
- TV format "16:9": "automatically" or "always 16:9"

TV-SCART-OUTPUT

Here you can use the   buttons to select the type of video signal at the TV Scart socket. Select the signal that your TV set can process. **When doing this, refer to the operating instructions for your TV set!**

- Composite baseband signal
(Colour Video Baseband Signal) or
- RGB - Red/Green/Blue signal

TELEVISION SYSTEM

Here you can use the   buttons to specify whether your TV set is a

- PAL or
- NTSC set.

HDMI FORMAT

Here you can use the   buttons to set the picture format to be transmitted to your TV set via HDMI,

Available options: "Auto" (automatic format choice), 576p, 720p or 1080i

Press the  button to exit the menu again.

SETTINGS

SUIT SCREEN MENU

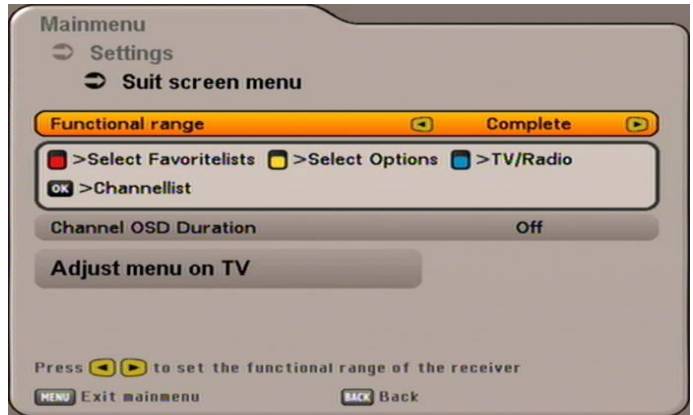

FUNCTIONAL RANGE

Here you can configure the functional scope of your receiver. You can choose between “Complete”, “Simple” and “Medium”. The following table shows which functions are available at each configuration step.

	(red) button	(yellow) button	(blue) button	button	button
High	Select Favoritelists	Select Options	TV/Radio	AV changeover	Channellist
Low	Not assigned	Not assigned	Not assigned	Not assigned	Programme Guide
Normal	Select Favoritelists	Select Options	TV/Radio	Not assigned	Programme Guide

CHANNEL OSD DURATION

Use the buttons to select the time after which you want the on-screen channel message display to be automatically cancelled. The selections available are “Off”, 1, 2, 3, 4, 5 or 6 Seconds.

ADJUST MENU ON TV

Press the button to align the on-screen displays on the TV screen. Now you can use the cursor buttons

to determine the position of the on-screen display. When you have achieved the desired position,

press the button to fix the desired position.





Press the button to exit the menu again.

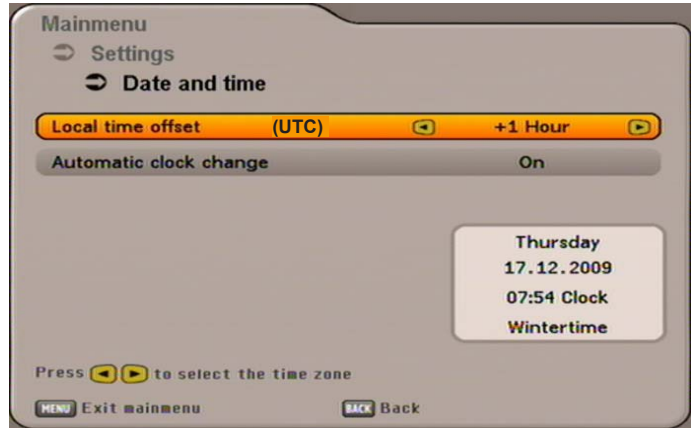

SETTINGS

DATE AND TIME







Local time offset

Use the   buttons to set the time zone variation from UTC (formerly GMT) (e.g. for Great Britain + 0 hours).

Use the   buttons to switch to the “Automatic clock change” field.

Automatic clock change

Use the   buttons to select whether the receiver should automatically change over to and from summer and winter time. If “On” is selected, the receiver automatically sets itself to the right time. If “Off” is selected, the field for manual selection of summer and winter time is displayed below.

The   buttons are also used to perform the setting.

Press the  button to exit the menu again.

COMMON INTERFACE



Always follow the operating instructions from your Pay-TV provider and the instructions supplied with the Smartcard and the CA module!

Smartcards and CA modules are not included with this product!

The cards and modules are issued by the respective pay TV providers, and contain the subscriber data and details of the channels for which the subscriber has paid. These channels are always scrambled.

Contact the Pay TV provider if you are interested in subscribing to a particular Pay TV channel.

You are responsible for the use of the Smartcard in the CA!

The Smartcard sold by the pay TV provider, specific to a particular encryption technology, is inserted into the CA module.

Store your card and PIN code securely when not in use!

SETTINGS

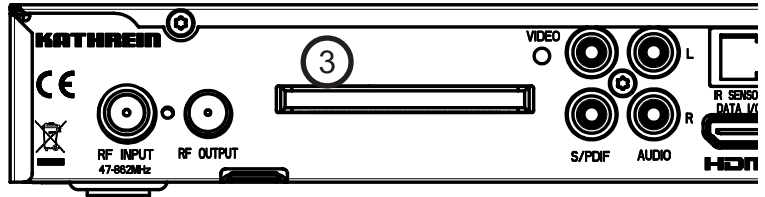
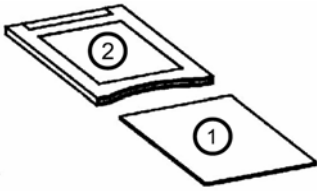

Inserting the CA module into the CI

The Common Interface (CI) (3) of the UFC 662sw is suitable for insertion of a CA (Conditional Access) module and is located at the rear of the receiver. The CA module (2) draws in the Smartcard (1) (chip contacts pointing downwards and towards socket strip) which it then inserts into the CI slot (3). The Smartcard should be inserted into the CA module without exerting excessive force. This also applies to inserting the CA module into the CI slot! Do not use a lot of force and follow the instructions supplied with the Smartcard and the CA module. To remove the CA module, pull the CA module back out of the Common Interface.

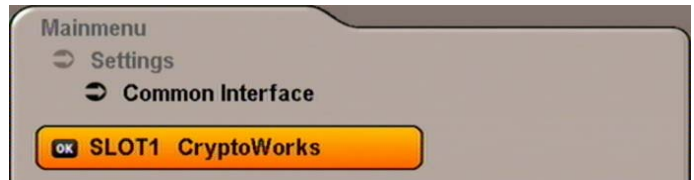

The screenshots below depend on the specific module and card, and so are only intended as examples:

Press the button to access the menu generated by the CA module:

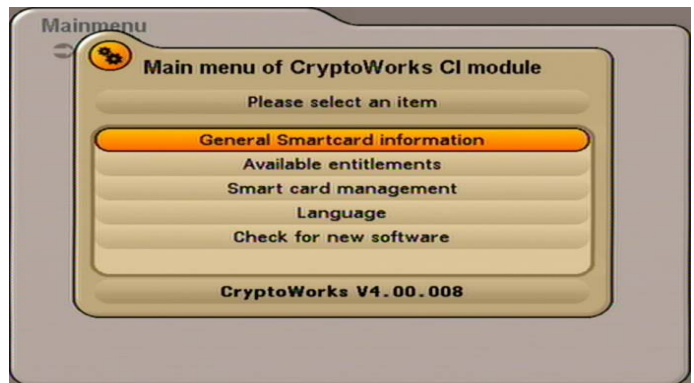

From this menu, your card and your PIN code allow you to access various channels from your Pay-TV provider.

"CryptoWorks" has been selected as an example here. The details can be different for each CA module. Always follow the instructions supplied by your pay TV provider!

Note: *The module displays may be shown in English, even if you have selected German as the menu language, because the menu is generated directly by the module!*

SETTINGS



Information for Conax, SECA, Viaccess and CryptoWorks users:

Note that with monthly activation intervals, the channel providers have different procedures for activating pay TV cards. Activation may therefore be a few days before or after the beginning of a new month. During this activation period, the CA module and card must be in the slot, and the receiver must be turned on a set to the booked Pay TV channel. Follow the instructions from the pay TV provider.

If your pay TV card is then still not enabled, we recommend you briefly withdraw the CA module with the card out of the slot, with the receiver switched on, and then re-insert it.

This information has nothing to do with the properties of the receiver; it is merely intended to assist you.

SERVICE MENU

Select the “Service” menu using the **MENU** button, the **▲▼** buttons in the main menu and **OK**. The following display appears:

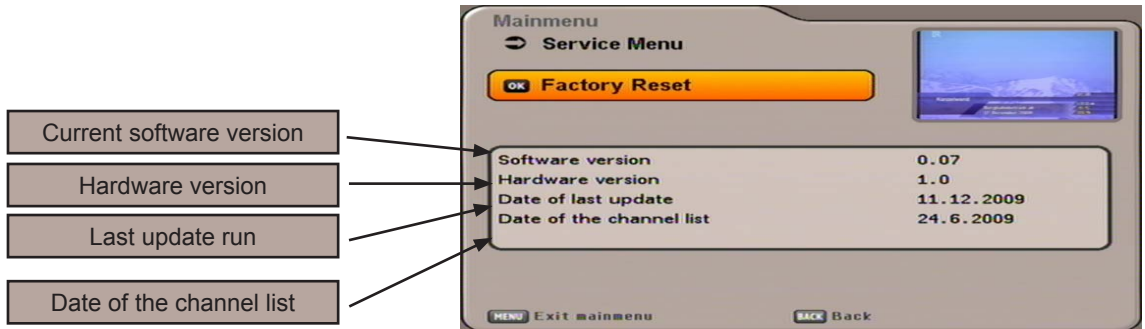

FACTORY RESET

Select the “Service” menu using the **MENU** button, the **▲▼** buttons in the main menu and **OK**.

Use the **▲▼** buttons to switch to “Factory Reset” and to call them up press the **OK** button. The following display appears:

You are now prompted to enter the PIN code (factory default setting: 0000). After entering the PIN using the number pad you are shown the following display:



Press the **OK** button to load the factory settings. You will also be asked if you wish too delete the channel list. Press the **OK** button to delete the channel list, or press the **BACK** button merely to reset to settings. Following the factory reset the receiver then automatically starts the First Installation procedure.

CONNECTING UP THE VIDEO/PVR

For details of how to connect an external recorder to the PVR, refer to the connection diagram in the “Connection and Setup” section in this manual, and to the instructions for the external recorder.

RECORDING

In order to make a VCR recording (Record), the cable receiver must be switched on, or the timers must be pre-programmed (see “EPG” “Recording (timer)” section).



Connecting a video recorder/PVR to the TV Scart socket allows you only to record. It does not allow you to play back on the TV set via the receiver. If you are recording via an external video recorder/PVR, remember not to operate the receiver during recording, otherwise all the on-screen displays will appear on your recording.

USING THE FRONT PANEL/SERVICE

If you have misplaced your remote control, or if the batteries are flat, you can still operate your receiver from the front panel.

BACKUP OPERATION

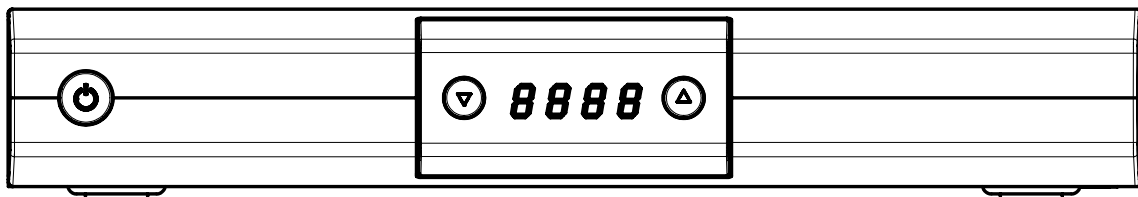

There are three buttons on the front of the receiver:

Power switch ¹⁾ (On/Off):

The power switch allows you to switch the receiver on (operation) and off again. You have no facility to switch the receiver into stand-by mode, since no stand-by switch is provided on the front or rear of the unit.

▼ button:

The channel down button switches to the next channel down in the currently selected channel list.

▲ button:

The channel up button switches to the next channel up in the currently selected channel list.



Because there are no numbered buttons, no password/PIN-protected functions can be displayed.

¹⁾ The unit is not fully disconnected from the mains (see the sections "Safety Instructions - Important Instructions" and "Periods of extended absence, thunderstorms, mains socket accessibility")

SERVICE

If, despite studying this operating manual, you still have questions about getting started with the unit or using it correctly, or if unexpected problems occur, please contact your specialist dealer. The Kathrein customer hotline is also at your disposal.

Tel: 0900/1122240 *

* (0.49 EUR per minute on Deutsche Telekom AG land lines, calls from mobile phones may cost more)

TECHNICAL APPENDIX

Type		UFC 662sw
Part no.		20210150
Colour		Black
RF properties		
Input frequency range	MHz	47-862
Input level range	dB μ V	46-86
Demodulation		QAM 16, 32, 64, 128, 256
TV system, video		
Modulation, FEC, demultiplexer		DVB-C standard
Video resolution		CCIR 601 (720 x 576 lines), 576p, 720p, 1080i
Video decryption		MPEG-1 and -2 compatible
Bit rate	MBit/s	1.5-15
TV system, audio		
Audio decoding		MPEG-1 and -2, layer 1 and 2
Sampling rate	kHz	32/44.1/48
S/N	dB	> 53
Power Supply		
Mains voltage (external power supply)	V _{AC} /Hz	230/50
DC	V	12
Power consumption (max./typ. operation/standby)	W	< 15/11/< 1
Connections		
RF input/output		F socket/IEC plug
TV output		1 x Scart sockets
Video output		Cinch socket
Video/audio output (digital)		1 x HDMI
Audio output (analogue)		2 x Cinch sockets
Audio digital output (electrical)		Cinch socket
Data interface		RJ 11 socket
Common Interface/Encryption system		1/-
General Information		
Permissible ambient temperature	°C	+5 to +40
Unit dimensions	mm	255 x 47 x 190
Weight	kg	1.0

TECHNICAL APPENDIX

SCART SOCKET ASSIGNMENT

Signal	Pin no.	TV	VCR/AUX
Right audio output	1	X	X
Right audio input	2		X
Left audio output	3	X	X
Audio earth	4	X	X
Blue earth	5	X	X
Audio left input	6		X
Blue signal	7	X	X
Switching voltage	8	X	X
Green earth	9	X	X
Data signal	10		
Green signal	11	X	X
Data signal	12		
Red earth	13	X	X
Data earth	14		
Red signal (C)	15	X	X
Blanking signal	16	X	X
Video earth	17	X	X
Blanking signal earth	18	X	X
Video output (FBAS/Y)	19	X	X
Video input	20		X
Connector shield	21	X	X

VHS/S-VHS SWITCHING

The Scart sockets are switchable between VHS and S-VHS. The changeover is performed by selecting "Main menu", "Settings", "TV, Video and Audio".

For VHS (RGB): The red signal is connected to terminal 15, the composite colour output to terminal 19.

For S-VHS (Y/C): The Y output is connected to pin 19, the C output to pin 15.

SHORT TECHNICAL GUIDE

AC 3

Output for Dolby Digital signal

AV programme pos.

Preferred programme slot on TV set for external connections such as Scart and HDMI

CAM – Conditional Access Module

Decryption decoder, which uses a smart card to decrypt the encrypted radio and TV signals.

CI - Common Interface

Internationally standardised interface for CA modules

Conditional Access (CA) system

Controls user access to services and programmes which are encrypted for reasons of copyright or for commercial reasons.

Data rate

Data bits transmitted per second. Is expressed in kbit/s or Mbit/s. The higher the data rate the better the quality of the transmitted signal.

Data reduction

Compression of video and audio signals. Redundant information is discarded.

Dolby Digital 5.1

Dolby Digital is a sound transmission that allows digital surround sound to be output on a home cinema system.

DVB - Digital Video Broadcasting

DVB-C refers to the transmission method (C = cable, S = satellite, T = terrestrial)

Eb/No ratio

The Eb/No ratio is a measure of the signal to noise ratio of a digital signal. The value is not identical to the C/N value familiar from analogue reception technology. At Eb/No values below 5 dB no reception is normally possible.

FEC

FEC is the abbreviation for Forward Error Correction. A technique for reducing the error rate of data transmission. Additional bits are inserted into the data stream, so that error-correction algorithms can be used on reception. The FEC error rate corresponds to the Viterbi rate.

HDMI - High Definition Multimedia Interface

Digital interface for digital video and audio data transmission (preferred for HDTV).

MPEG-2

MPEG is the abbreviation for Moving Picture Experts Group, a working group that formulates internationally applicable standards for the digital compression of video and audio. MPEG-2 has become established as the standard for compression of digital TV signals. MPEG-2 works up to a data rate of 100 Mbit/s.

MPEG-4

A further development of MPEG-2 with even higher data compression, intended for HDTV transmissions.

OSD - On-Screen Display

Displays by the receiver on the TV screen (e.g. main menu)

PAL

Analogue TV standard

Pay TV

Television channels available on subscription (e.g. Sky). Encrypted transmitters which can only be decrypted by using the appropriate smart card. As a rule these services are subscription-only.

PCMCIA

Standard for internal decoder interface for pay-TV

PIN

Personal Identification Number. For this unit the PIN is a 4-digit numeric code which must be entered to unlock the unit to allow access to certain functions and channels.

QAM - Quadrature-Amplitude-Modulation

Digital modulation process with phase shift keying, which is used for transmissions in cable networks.

Receivers

Receiver

RGB

Video signal made up of three individual colour signals (red, green, blue)

SHORT TECHNICAL GUIDE

Scart cable

21-pin connecting cable (e.g. receiver/TV)

Smart card

Card from Pay TV provider to decrypt its channels

Stand-by

Standby mode

Symbol Rate

The symbol rate describes the quantity of data that is transmitted per second. The symbol rate is measured in MSymbols/s and is equal to the number of symbols received per second.

Timer function

Clock function for pre-programmed switch on and off times

VCR/PVR connection

Connection for an external recorder (such as a video or DVD recorder)

Video bit rate

The video bit rate describes the quantity of data from the digitised video signal that is transmitted per second.

Viterbi rate

The Viterbi rate (code rate, error rate) characterises the error protection used by the programme provider. The DVB standard provides the following values: 1/2 - 2/3 - 3/4 - 5/6 - 7/8

TROUBLESHOOTING

In the event of a malfunction, first check all the cable connections and operating states:

1. Receiver and TV set power plugs are connected to wall socket
2. Antenna cables are connected to the receiver input
3. Receiver and TV set are correctly connected to each other by a HDMI or Scart or cinch cable
4. Audio connections are made to the Hi-Fi or Dolby Digital system as appropriate
5. Receiver and TV set (Hi-Fi/Dolby Digital system) are switched on (check power indicators)
6. Receiver is responding to remote control

A selection of troubleshooting tips is offered below.

Problem	Cause	Remedy
A "No signal!" warning appears on some or all channels	Antenna signal is absent or is defective.	Check the cable connection between your receiver and the cable socket. Refer to your cable network operator or an antenna specialist.
Remote control no longer responding	Receiver or remote control command set may have been unintentionally changed	Set infrared code 1 as described in this manual under "Main menu settings", "Basic settings", "Setting the remote control code", check the batteries
Wrong time being displayed	"Summer Time" setting wrong. An incorrect time was imported from the reception signal	On "Settings" - "Date and Time" setup menu check "Summer Time Enabled" and change as necessary Use the power switch to switch the receiver off from the current channel, e.g. Das Erste or ZDF, wait 10 seconds and then switch it back on

936.3719/-/0110/ZWT - Technical data subject to change.