

REB-1315LPNX Operational Manual

Version 1.0
2008/08/07

This document contains information highly confidential to RoyalTek Company LTD (RoyalTek). It is provided for the sole purpose of the business discussions between customer and RoyalTek and is covered under the terms of the applicable Non-Disclosure Agreements. Disclosure of this information to other parties is prohibited without the written consent of RoyalTek.

Prepared by RoyalTek Company LTD.

4F., No.188, Wen Hwa 2nd Rd., Kuei Shan,
Tao Yuan 333, Taiwan

TEL: 886-3-3960001

FAX: 886-3-3960065

<http://www.royaltek.com/contact>

Approved by	Checked by	Prepared by

文件編號：

Content

1. Introduction	3
1.1 Product Applications.....	3
1.2 Product Pictures.....	4
1.3 REB-1315LPNX Series Block Diagram.....	5
1.4 REB-1315LPNX Technical Specification	6
1.5 Application Circuit.....	7
1.6 Mechanical Layout	11
1.7 Hardware interface	12
2. Software Interface	16
3. GPS Receiver User’s Tip	21
4. Package Specification and Order Information.....	22
5. Matching active antenna	22
6. Contact Royaltek.....	23
7. Revision History	23

1. Introduction

RoyalTek REB-1315LPNX small form factor board is the newest generation of RoyalTek GPS module. The module is powered by latest SiRF Star III single chip and RoyalTek proprietary navigation technology that provides you with stable and accurate navigation data. The smallest form factor and miniature design is the best choice to be embedded in a device such as portable navigation device, personal locator, speed camera detector and vehicle locator.

Product Features

- ✧ 20 parallel channels
- ✧ SMT type with stamp holes
- ✧ TCXO design
- ✧ 0.1 second reacquisition time
- ✧ Small form factor with embedded SiRF Star III single chip technology.
- ✧ NMEA-0183 compliant protocol/ customize protocol
- ✧ Enhanced algorithm for navigation stability
- ✧ Excellent sensitivity for urban canyon and foliage environments.
- ✧ DGPS (WAAS, EGNOS) support
- ✧ Auto recovery while RTC crashes
- ✧ Build-in saw filter

1.1 Product Applications

- ✧ Automotive navigation
- ✧ Personal positioning and navigation
- ✧ Marine navigation
- ✧ Timing application

1.2 Product Pictures

(1) REB-1315LPNX



(2) REB-1315LPNX Interface board

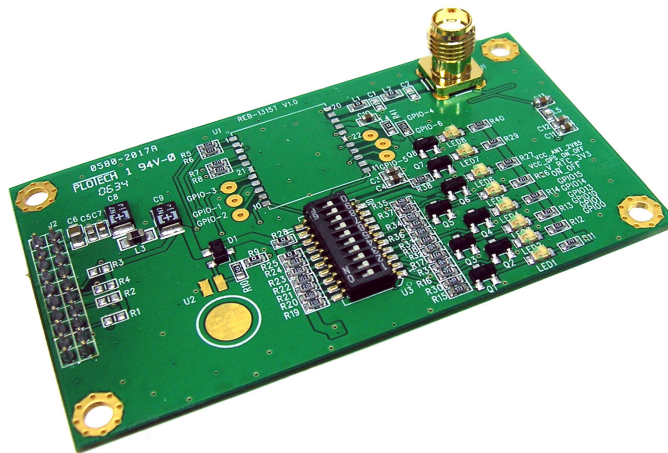

The interface board pin definition

RoyalTek Evaluation Kit REV-2000 for REB-1315LPNX

(Please refer to RoyalTek Evaluation Kit REV-2000 for REB-1315LPNX Operational Manual for more information)

1.3 REB-1315LPNX Series Block Diagram

System block diagram description:

- a. External antenna.
- b. 4 Mega bits flash memory.
- c. 22 pin I/O pin.

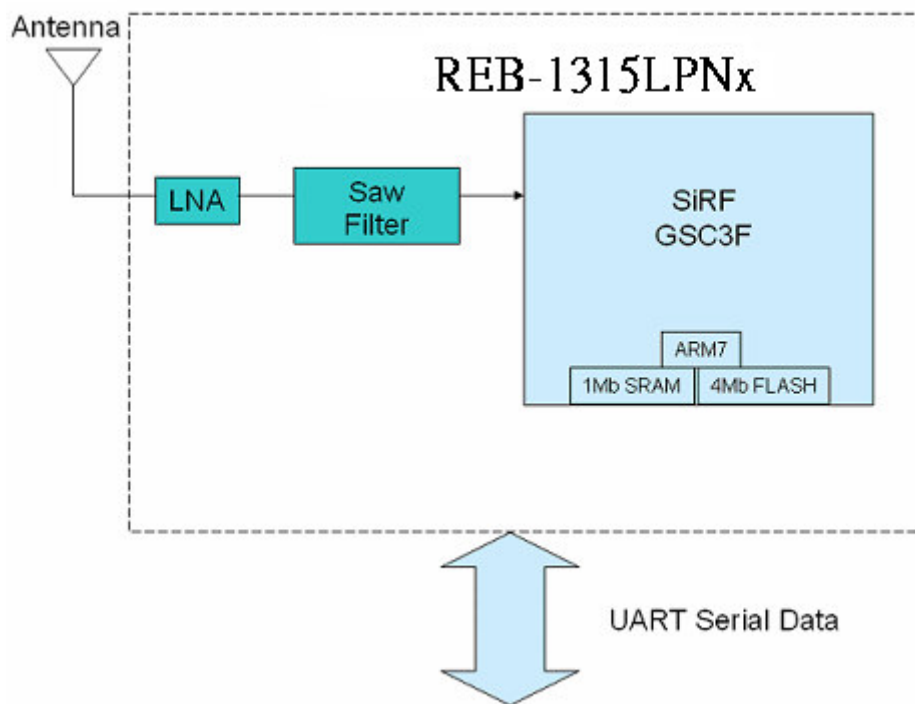

1.4 REB-1315LPNX Technical Specification

Impedance : 50Ω

No	Function	Specification
GPS receiver		
1	Chipset	SiRF Star III, GSC3f/LPx (Digital, RF in a single package)
2	Frequency	L1 1575.42MHz.
3	Code	C.A. Code.
4	Channels	20 parallel
5	Chip Sensitivity	-159dBm.
6	Chip Cold start (open sky)	35 sec
7	Chip Warm start(open sky)	35 sec
8	Chip Hot start (open sky)	1 se
9	Reacquisition	0.1sec typical
10	Position accuracy	10meters at 2D RMS.
11	Maximum altitude	18000 m
12	Maximum velocity	514 m/s
13	Trickle power mode	Duty cycle \leq 34%. (Variable)
14	Update rate	Continuous operation: 1Hz
15	DGPS	WAAS, EGNOS
Interface		
16	LNA	None
17	I/O Pin	22pin stamp holes
Mechanical requirements		
18	Weight	\leq 3.5g
Power consumption		
19	Vcc	DC 3.3 \pm 5%
20	Current	Avg. < 25mA@3.3V (Acquisition w/o ext. Antenna)
Environment		
21	Operating temperature	-40 ~ 85°C
22	Storage temperature	-40 ~ 85°C
23	Humidity	\leq 95%

1.5 Application Circuit

Reference schematic:

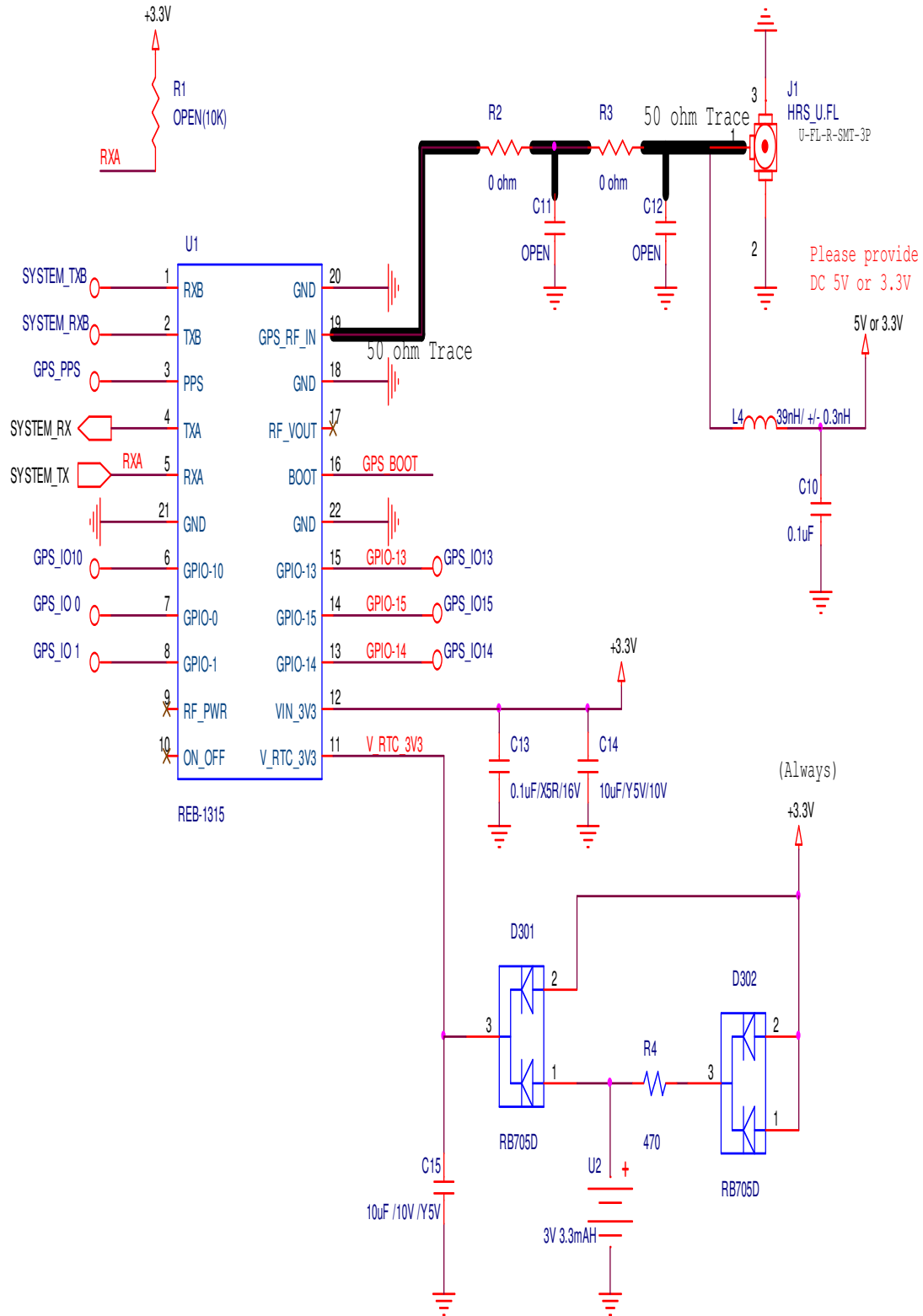

Note:

(1) Ground Planes:

These pin(18、20、21、22) should be connect to ground.

(2) Serial Interface:

(I)The TXA pin is the serial output data. Default output GPS protocol. (NMEA sentence).

(II). The RXA pin is the serial input data. Default output GPS protocol. (NMEA sentence)

(III) The TXB pin is the serial output data (Default Null)

(IV) The RXB pin is the serial input data (Default Null).

(3) Backup Battery:

It's recommended to connect a backup battery to V_RTC_3V3 pin.

In order to enable the warm start and hot start features of the GPS receiver.

If you use backup battery, should be adding a bypassing capacitor (10uF) at V_RTC_3V3 pin. It can reduce noise and increase the stability.

(4) RF_IN:

Connecting to the antenna has to be routed on the PCB. The transmission line must to be control impedance from RF_IN pin to the antenna or antenna connector of your choice. (Impedance 50Ω)

(5) Power:

Connect V_GPS_3V3 pin to DC 3.3V. The power supply must add bypass capacitor (10uF and 1uF).It can reduce the Noise from power supply and increase power stability.

(6) Active antenna bias voltage:

The RF_OUT pin (pin 17) is provide voltage 2.85V. If you use active antenna, you can use this pin to provide bias voltage for active antenna, but you must design the RF chock circuit to avoid the RF signal jamming.

P.S. :

(1) This pin can provide maximum current is 30mA @ 2.85V.

(2) The active antenna input gain ranges are recommend 25~ 30dB.

(7) GPIO:

The GPIOs functions are for customer used.

If no use GPIO functions, it doesn't connect anything.

Recommend Layout PAD :

Dimension : 13mm*15mm*2.2mm(Tolerance : $\pm 0.2\text{mm}$)

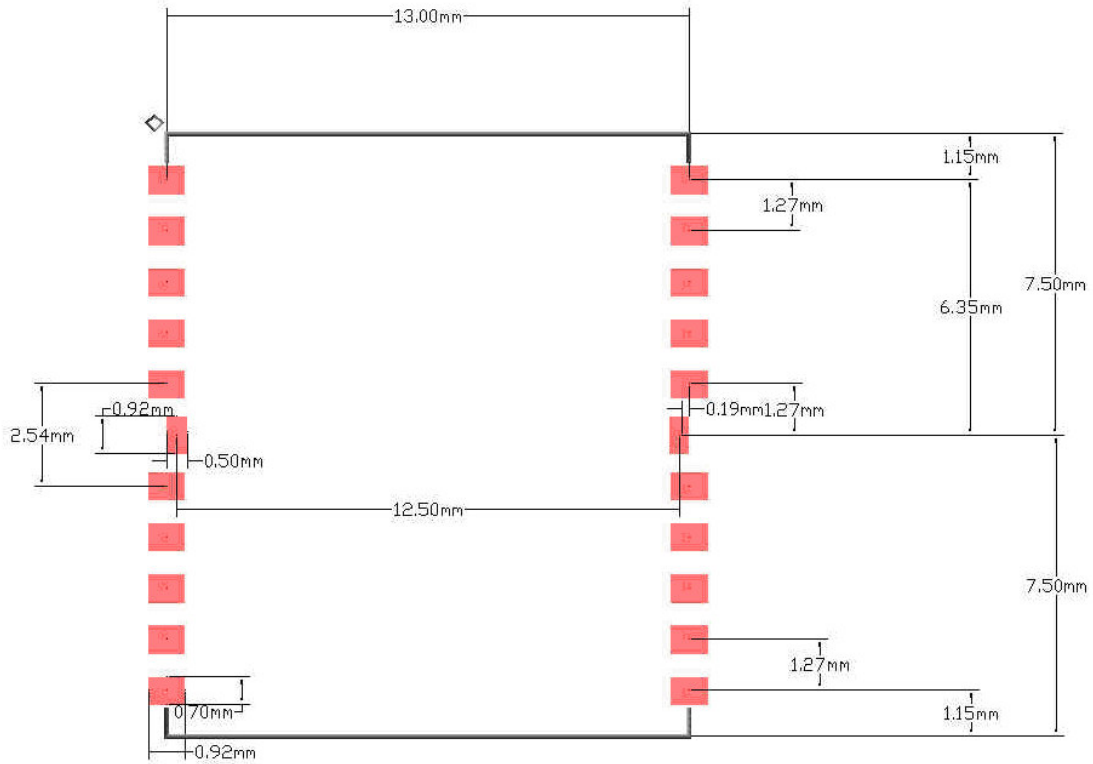

TOP View

Recommend paste mask pad

Recommend paste mask pad is shift outside the layout pad 0.2mm(See under figure)

Black Block is layout PAD、Blue Block(Gray region is paste mask pad recommend)

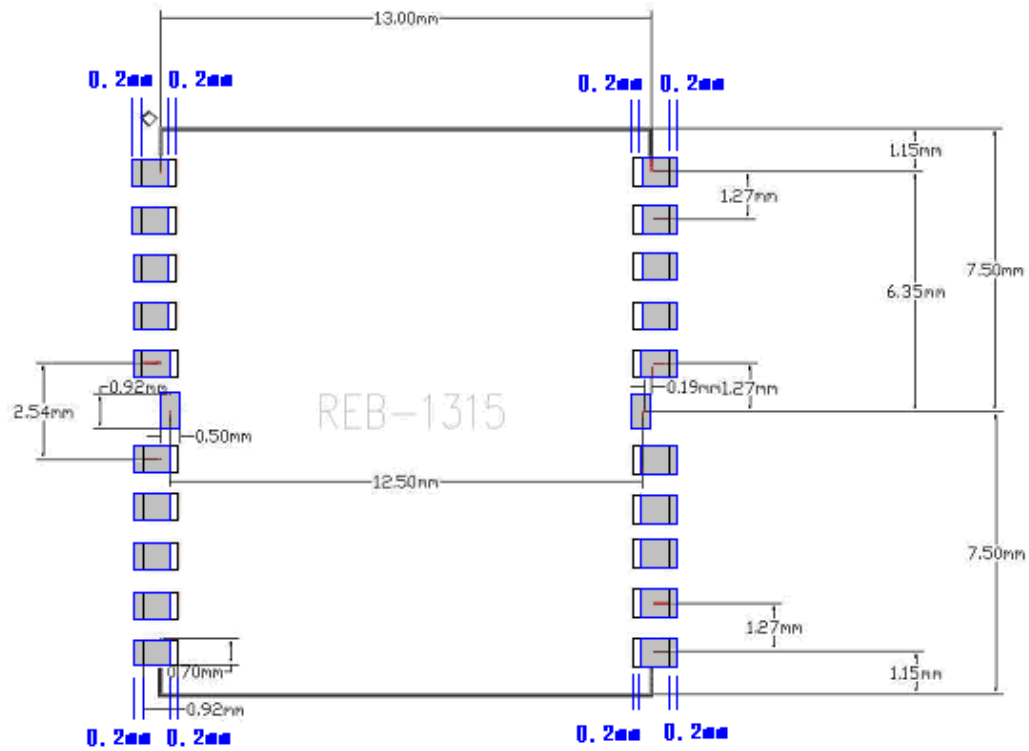

TOP View

1.6 Mechanical Layout

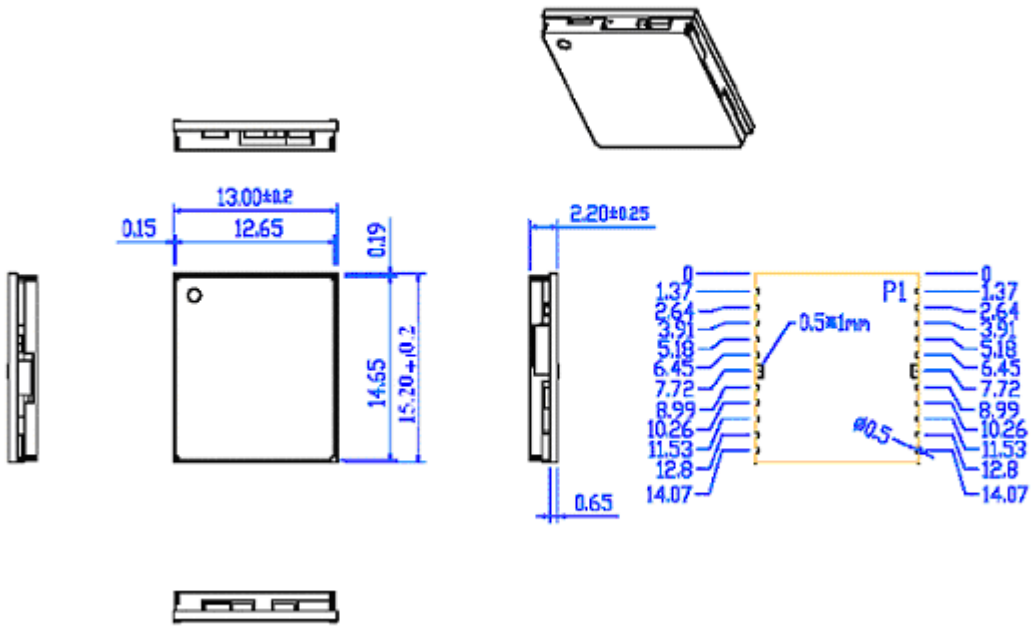

1.7 Hardware interface

Interface Pin Number:

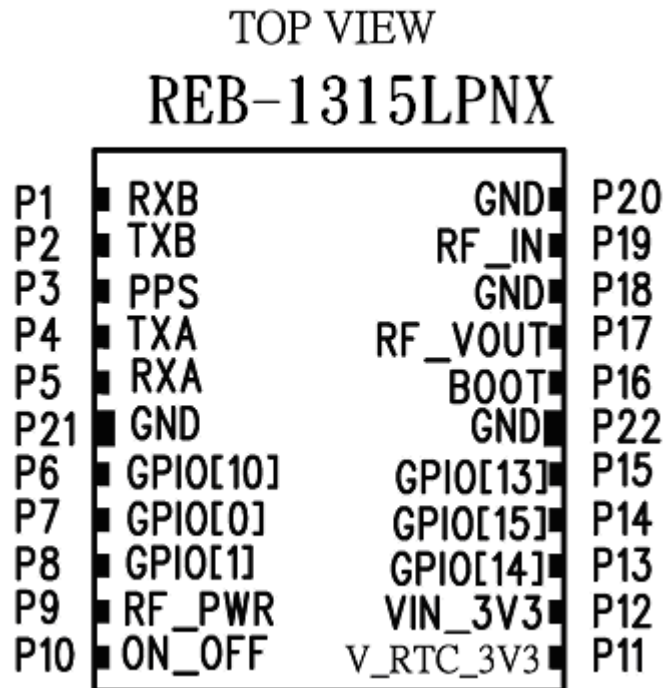

Pin defined:

Pin	Signal Name	I/O	Description	Characteristics
1	RXB	I	Serial port B	$3.15 \geq V_{IH} \geq 1.995V$ $-0.3V \leq V_{IL} \leq 0.855V$
2	TXB	O	Serial port B	$2.85V \geq V_{OH} \geq 2.375V$ $V_{OL} \leq 0.715V$
3	PPS	O	One pulse per second	$2.85V \geq V_{OH} \geq 2.375V$ $V_{OL} \leq 0.715V$
4	TXA	O	Serial port A	$2.85V \geq V_{OH} \geq 2.375V$ $V_{OL} \leq 0.715V$
5	RXA	I	Serial port A	$3.15V \geq V_{IH} \geq 1.995V$ $-0.3V \leq V_{IL} \leq 0.855V$
6	GPIO[10]	I/O	General purpose I/O	$3.15 \geq V_{IH} \geq 1.995V$ $-0.3V \leq V_{IL} \leq 0.855V$ $2.85V \geq V_{OH} \geq 2.375V$ $V_{OL} \leq 0.715V$
7	GPIO[0]	I/O	General purpose I/O	$3.15 \geq V_{IH} \geq 1.995V$ $-0.3V \leq V_{IL} \leq 0.855V$ $2.85V \geq V_{OH} \geq 2.375V$ $V_{OL} \leq 0.715V$
8	GPIO[1]	I/O	General purpose I/O	$3.15 \geq V_{IH} \geq 1.995V$ $-0.3V \leq V_{IL} \leq 0.855V$ $2.85V \geq V_{OH} \geq 2.375V$ $V_{OL} \leq 0.715V$
9	RF_PWR	O	Indicates power state of RF part	$V_{OH} = 2.85V$ $V_{OL} = 0V$
10	ON_OFF	I	Edge triggered soft on/off request.	$3.15 \geq V_{IH} \geq 1.995V$
11	V_RTC_3V3	I	Backup voltage supply	DC + 2.5 ~ +3.6V Current $\leq 10\mu A$
12	VIN_3V3	I	DC Supply Voltage input	DC +3.3V \pm 5%
13	GPIO[14]	I/O	General purpose I/O	$3.15 \geq V_{IH} \geq 1.995V$ $-0.3V \leq V_{IL} \leq 0.855V$ $2.85V \geq V_{OH} \geq 2.375V$ $V_{OL} \leq 0.715V$
14	GPIO[15]	I/O	General purpose I/O	$3.15 \geq V_{IH} \geq 1.995V$ $-0.3V \leq V_{IL} \leq 0.855V$ $2.85V \geq V_{OH} \geq 2.375V$ $V_{OL} \leq 0.715V$
15	GPIO[13]	I/O	General purpose I/O	$3.15 \geq V_{IH} \geq 1.995V$ $-0.3V \leq V_{IL} \leq 0.855V$ $2.85V \geq V_{OH} \geq 2.375V$ $V_{OL} \leq 0.715V$
16	Boot	I	Boot mode	$3.15 \geq V_{IH} \geq 1.995V$ $-0.3V \leq V_{IL} \leq 0.855V$
17	RF_VOUT	O	Supply Antenna	$V_O = 2.85V \pm 5\%$ Current 30mA

			Bias voltage	
18	GND	G	Ground	Reference Ground
19	RF_IN	I	GPS Signal input	50 Ω @1.57542GHz
20	GND	G	Ground	Reference Ground
21	GND	G	Ground	Reference Ground
22	GND	G	Ground	Reference Ground

VIN_3V3(+3.3V DC power Input)

This is the DC power supply input pin for GPS system. It provides voltage to module.

GND

GND provides the reference ground.

Boot

Set this pin to high for programming flash.

RXA

This is the main receiver channel and is used to receive software commands to the board from SIRFdemo software or from user written software.

RXB

This is the auxiliary receiving channel and is used to input differential corrections to the board to enable DGPS navigation. (Default Null).

TXA

This is the main transmitting channel and is used to output navigation and measurement data to SiRFdemo or user written software.

TXB

For user's application (not currently used). (Default Null).

RF_PWR

This pin indicates state of RF voltage.

RF_IN

This pin receives GPS analog signal. The line on the PCB between the antenna(or antenna connector) has to be a controlled impedance line (Microstrip at 50 Ω).

RF_VOUT

This pin can provide maximum power 30mA@2.85V for active antenna.

PPS

This pin provides one pulse-per-second output from the board, which is synchronized to GPS time. This is not available in Trickle Power mode.

V_RTC_3V3 (Backup battery)

This is the battery backup input that powers the SRAM and RTC when main power is removed. Typical current draw is 10uA.

The supply voltage should be between 2.5V and 3.6V.

ON_OFF

Edge triggered soft on/off request. Should only be used to wake up chip.

GPIO Functions

Several I/Os are connected to the digital interface connector for custom applications.

2. Software Interface

NMEA Protocol

NMEA Output Messages: the Engine board outputs the following messages as shown in Table 1:

Table 1 NMEA-0183 Output Messages

NMEA Record	Description
GGA	Global positioning system fixed data
GSA	GNSS DOP and active satellites
GSV	GNSS satellites in view
RMC	Recommended minimum specific GNSS data
GLL	Geographic position – latitude/longitude
VTG	Course over ground and ground speed

GGA-Global Positioning System Fixed Data

Table 2 contains the values of the following example:

\$GPGGA, 161229.487, 3723.2475, N, 12158.3416, W, 1, 07, 1.0, 9.0, M, , , ,0000*18

Table 2 GGA Data Format

Name	Example	Units	Description
Message ID	\$GPGGA		GGA protocol header
UTC Position	161229.487		hhmmss.sss
Latitude	3723.2475		ddmm.mmmm
N/S Indicator	N		N=north or S=south
Longitude	12158.3416		Dddmm.mmmm
E/W Indicator	W		E=east or W=west
Position Fix Indicator	1		See Table 2-1
Satellites Used	07		Range 0 to 12
HDOP	1.0		Horizontal Dilution of Precision
MSL Altitude	9.0	meters	
Units	M	meters	
Geoid Separation		meters	
Units	M	meters	
Age of Diff. Corr.		second	Null fields when DGPS is not used
Diff. Ref. Station ID	0000		
Checksum	*18		
<CR> <LF>			End of message termination

Table 3 Position Fix Indicators

Value	Description
0	Fix not available or invalid
1	GPS SPS Mode, fix valid
2	Differential GPS, SPS Mode, fix valid
3-5	Not Supported
6	Dead Reckoning Mode, fix valid

GSA-GNSS DOP and Active Satellites

Table 4 contains the values of the following example:

\$GPGSA, A, 3, 07, 02, 26, 27, 09, 04, 15, , , , , 1.8,1.0,1.5*33

Table 4 GSA Data Format

Name	Example	Units	Description
Message ID	\$GPGSA		GSA protocol header
Mode 1	A		See Table 5
Mode 2	3		See Table 6
ID of Satellite Used	07		Sv on Channel 1
ID of Satellite Used	02		Sv on Channel 2
....		
ID of Satellite Used			Sv on Channel 12
PDOP	1.8		Position Dilution of Precision
HDOP	1.0		Horizontal Dilution of Precision
VDOP	1.5		Vertical Dilution of Precision
Checksum	*33		
<CR> <LF>			End of message termination

Table 5 Mode 1

Value	Description
M	Manual-forced to operate in 2D or 3D mode
A	Automatic-allowed to automatically switch 2D/3D

Table 6 Mode 2

Value	Description
1	Fix not available

2	2D
3	3D

GSV-GNSS Satellites in View

Table 7 contains the values of the following example:

\$GPGSV, 2, 1, 07, 07, 79, 048, 42, 02, 51, 062, 43, 26, 36, 256, 42, 27, 27, 138, 42*71

\$GPGSV, 2, 2, 07, 09, 23, 313, 42, 04, 19, 159, 41, 15, 12, 041, 42*41

Table 7 GSV Data Format

Name	Example	Units	Description
Message ID	\$GPGSV		GSV protocol header
Total Number of Messages ¹	2		Range 1 to 3
Messages Number ¹	1		Range 1 to 3
Satellites in View	07		
Satellite ID	07		Channel 1(Range 1 to 32)
Elevation	79	degrees	Channel 1(Range 00 to 90)
Azimuth	048	degrees	Channel 1(True, Range 000 to 359)
SNR (C/No)	42	dBHz	Channel 1(Range 0 to 99, null when not tracking)
Satellite ID	27		Channel 4(Range 01 to 32)
Elevation	27	degrees	Channel 4(Range 00 to 90)
Azimuth	138	degrees	Channel 4(True, Range 000 to 359)
SNR (C/No)	42	dB-Hz	Channel 4(Range 00 to 99, null when not tracking)
Checksum	*71		
<CR> <LF>			End of message termination

¹Depending on the number of satellites tracked multiple messages of GSV data may be required.

RMC-Recommended Minimum Specific GNSS Data

Table 8 contains the values of the following example:

\$GPRMC, 161229.487, A, 3723.2475, N, 12158.3416, W, 0.13, 309.62, 120598, ,*10

Table 8 RMC Data Format

Name	Example	Units	Description
Message ID	\$GPRMC		RMC protocol header
UTC Time	161229.487		hhmmss.sss

Status	A		A=data valid or V=data not valid
Latitude	3723.2475		ddmm.mmmm
N/S Indicator	N		N=north or S=south
Longitude	12158.3416		dddmm.mmmm
E/W Indicator	W		E=east or W=west
Speed Over Ground	0.13	knots	True
Course Over Ground	309.62	degrees	
Date	120598		ddmmyy
Magnetic Variation		degrees	
Variation sense			E=east or W=west (Not shown)
Mode	A		A=Autonomous, D=DGPS, E=DR
Checksum	*10		
<CR><LF>			End of message termination

VTG-Course Over Ground and Ground Speed

Table 9 contains the values of the following example:

\$GPVTG,79.65,T,,M,2.69,N,5.0,K,A*38

Table 9 VTG Data Format

Name	Example	Units	Description
Message ID	\$GPVTG		VTG protocol header
Course over rground	79.65	degrees	Measured heading
Reference	T		True
Course over ground		degrees	Measured heading
Reference	M		Magnetic
Speed over ground	2.69	Knots	Measured speed
Units	N		Knots
Speed over ground	5.0	Km/hr	Measured speed
Units	K		Kilometer per hour
Mode	A		A-autonomous, D=DGPS, E=DR
Checksum	*38		
<CR><LF>			End of message termination

GLL-Geographic Position – Latitude/Longitude

Table 10 contains the values of the following example:

\$GPGLL,2503.6319,N,12136.0099,E,053740.000,A,A*52

Table 10 GLL Data Format

Name	Example	Units	Description
Message ID	\$GPGLL		GLL protocol header
Latitude	2503.6319		ddmm.mmmm
N/S indicator	N		N=north or S=south
Longitude	12136.0099		Dddmm.mmmm
E/W indicator	E		E=east or W=west
UTC Time	053740.000		hhmmss.sss
Status	A		A=data valid or V=data not valid
Mode	A		A=autonomous, D=DGPS, E=DR
Checksum	*52		
<CR><LF>			End of message termination

3. GPS Receiver User's Tip

- A. GPS signal will be affected by weather and environment conditions, so it is recommended to use the GPS receiver under less shielding environments to ensure GPS receiver has better receiving performance.
- B. When GPS receiver is moving, it will prolong the time to fix the position, so it is recommended to wait for the satellite signals locked at a fixed point when first power-on the GPS receiver to ensure to lock the GPS signal at the shortest time.
- C. The following situation will affect the GPS receiving performance:
 - i. Solar control filmed windows.
 - ii. Metal shielded, such as umbrella, or in vehicle.
 - iii. Among high buildings.
 - iv. Under bridges or tunnels.
 - v. Under high voltage cables or near by radio wave sources, such as mobile phone base stations.
 - vi. Bad or heavy cloudy weather.
- D. If the satellite signals can not be locked or encounter receiving problem (while in the urban area), the following steps are suggested:
 - i. Please plug the external active antenna into GPS receiver and put the antenna on outdoor or the roof of the vehicle for better receiving performance.
 - ii. Move to another open space or reposition GPS receiver toward the direction with less blockage.
 - iii. Move the GPS receiver away from the interferences resources.
 - iv. Wait until the weather condition is improved.
- E. While a GPS with a backup battery, the GPS receiver can fix a position immediately at next power-on if the build-in backup battery is full-recharged.

4. Package Specification and Order Information

Shipment Method: Tape and reel

SMT type with stamp holes (22 holes)

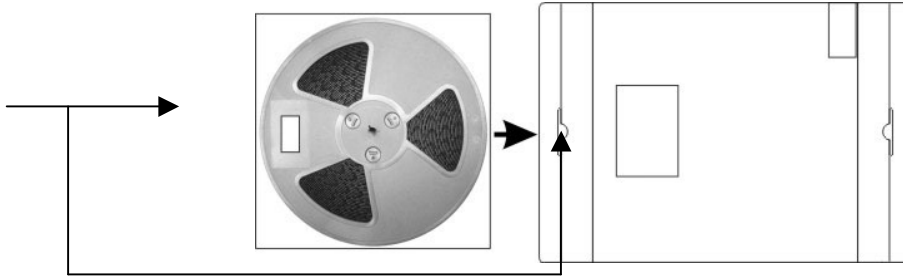

5. Matching active antenna

REB-1315LPN/LPNX	ZANTEN1257G	
------------------	-------------	---

6. Contact Royaltek

. Contact: sales@royaltek.com

. Headquarter:

Address : 4F., No.188, Wen Hwa 2nd Rd., Kuei Shan, Tao Yuan 333, Taiwan
TEL: 886-3-3960001
FAX: 886-3-3960065

. Web Site: <http://www.royaltek.com>

. Web Site Customer Service: <http://www.royaltek.com/contact>

7. Revision History

Title	REB-1315LPNX GPS Receiver Module		
Doc Type	User Manual		
Revision Number	Date	Author	Change notice
1.0	2007/08/07	Amy Liu	Initial Release

Copyright © 2007-2008, RoyalTek Company Ltd.