

SONY®

Digital Still Camera

Operating Instructions

Before operating the unit, please read this manual thoroughly, and retain it for future reference.

Owner's Record

The model and serial numbers are located on the bottom. Record the serial number in the space provided below.

Refer to these numbers whenever you call upon your Sony dealer regarding this product.

Model No. DSC-U10

Serial No. _____

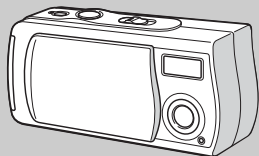

Cyber-shot U



DSC-U10

© 2002 Sony Corporation

3-076-559-12(1)

Getting started _____

Shooting still images _____

Viewing still images _____

Enjoying movies _____

Deleting images _____

Copying images _____

Troubleshooting _____

Additional information _____

Index

WARNING

To prevent fire or shock hazard, do not expose the unit to rain or moisture.

For the Customers in the U.S.A.

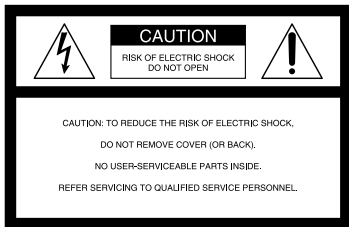

This symbol is intended to alert the user to the presence of uninsulated “dangerous voltage” within the product’s enclosure that may be of sufficient magnitude to constitute a risk of electric shock to persons.



This symbol is intended to alert the user to the presence of important operating and maintenance (servicing) instructions in the literature accompanying the appliance.

If you have any questions about this product, you may call:
Sony Customer Information Services Center
1-800-222-SONY (7669)

The number below is for the FCC related matters only.

Declaration of Conformity

Trade Name: SONY
Model No.: DSC-U10
Responsible Party: Sony Electronics Inc.
Address: 680 Kinderkamack Road, Oradell,
NJ 07649 USA
Telephone No.: 201-930-6972
This device complies with Part 15 of the FCC Rules.
Operation is subject to the following two conditions: (1)
This device may not cause harmful interference, and
(2) this device must accept any interference received,
including interference that may cause undesired
operation.

CAUTION

You are cautioned that any changes or modifications not expressly approved in this manual could void your authority to operate this equipment.

Note:

This equipment has been tested and found to comply with the limits for a Class B digital device, pursuant to Part 15 of the FCC Rules. These limits are designed to provide reasonable protection against harmful interference in a residential installation. This equipment generates, uses, and can radiate radio frequency energy and, if not installed and used in accordance with the instructions, may cause harmful interference to radio communications. However, there is no guarantee that interference will not occur in a particular installation. If this equipment does cause harmful interference to radio or television reception, which can be determined by turning the equipment off and on, the user is encouraged to try to correct the interference by one or more of the following measures:

- Reorient or relocate the receiving antenna.
- Increase the separation between the equipment and receiver.
- Connect the equipment into an outlet on a circuit different from that to which the receiver is connected.
- Consult the dealer or an experienced radio/TV technician for help.

The supplied interface cable must be used with the equipment in order to comply with the limits for a digital device pursuant to Subpart B of Part 15 of FCC Rules.

For the Customers in the U.S.A. and Canada

RECYCLING NICKEL METAL HYDRIDE BATTERIES

Nickel Metal Hydride batteries are recyclable.

You can help preserve our environment by returning your used rechargeable batteries to the collection and recycling location nearest you.



For more information regarding recycling of rechargeable batteries, call toll free 1-800-822-8837, or visit <http://www.rbrc.org/>

CAUTION:

Do not handle damaged or leaking Nickel Metal Hydride batteries.

CAUTION

TO PREVENT ELECTRIC SHOCK, DO NOT USE THIS POLARIZED AC PLUG WITH AN EXTENSION CORD, RECEPTACLE OR OTHER OUTLET UNLESS THE BLADES CAN BE FULLY INSERTED TO PREVENT BLADE EXPOSURE.

Notice for the customers in the United Kingdom

A moulded plug complying with BS 1363 is fitted to this equipment for your safety and convenience.

Should the fuse in the plug supplied need to be replaced, a 5 AMP fuse approved by ASTA or BSI to BS 1362, (i.e., marked with ⬡ or ♡ mark) must be used.

If the plug supplied with this equipment has a detachable fuse cover, be sure to attach the fuse cover after you change the fuse. Never use the plug without the fuse cover. If you should lose the fuse cover, please contact your nearest Sony service station.

For the Customers in Germany

Directive: EMC Directive 89/336/EEC, 92/31/EEC
This equipment complies with the EMC regulations when used under the following circumstances:

- Residential area
- Business district
- Light-industry district

(This equipment complies with the EMC standard regulations EN55022 Class B.)

Attention for the Customers in Europe

This product has been tested and found compliant with the limits sets out on the EMC Directive for using connection cables shorter than 3 meters.

Attention

The electromagnetic fields at the specific frequencies may influence the picture and sound of this camera.

Notice

If static electricity or electromagnetism causes data transfer to discontinue midway (fail), restart the application or disconnect and connect the USB cable again.

“Memory Stick”



For the Customers in the U.S.A. and Canada

THIS DEVICE COMPLIES WITH PART 15 OF THE FCC RULES. OPERATION IS SUBJECT TO THE FOLLOWING TWO CONDITIONS:

(1) THIS DEVICE MAY NOT CAUSE HARMFUL INTERFERENCE, AND (2) THIS DEVICE MUST ACCEPT ANY INTERFERENCE RECEIVED, INCLUDING INTERFERENCE THAT MAY CAUSE UNDESIRED OPERATION.

THIS CLASS B DIGITAL APPARATUS COMPLIES WITH CANADIAN ICES-003.

Before using your camera

Trial recording

Before you record one-time events, you may want to make a trial recording to make sure that the camera is working correctly.

No compensation for contents of the recording

Contents of the recording cannot be compensated for if recording or playback is not possible due to a malfunction of your camera or recording media, etc.

Notes on image data compatibility

- This camera conforms with the Design rule for Camera File system universal standard established by the JEITA (Japan Electronics and Information Technology Industries Association).
- Playback of images recorded with your camera on other equipment and playback of images recorded or edited with other equipment on your camera are not guaranteed.

Note on “Memory Stick”

This camera turns off whenever you remove the batteries or the “Memory Stick.” Do not open the battery/“Memory Stick” cover while the access lamp is on.

Precaution on copyright

Television programs, films, video tapes, and other materials may be copyrighted. Unauthorized recording of such materials may be contrary to the provision of the copyright laws.

Do not shake or strike the camera

In addition to malfunctions and inability to record images, this may render the “Memory Stick” unusable or image data breakdown, damage or loss may occur.

LCD screen, LCD finder (only models with a finder) and lens

- The LCD screen and the LCD finder are manufactured using extremely high-precision technology so over 99.99% of the pixels are operational for effective use. However, there may be some tiny black points and/or bright points (white, red, blue or green in color) that constantly appear on the LCD screen and the LCD finder. These points are normal in the manufacturing process and do not affect the recording in any way.
- Be careful when placing the camera near a window or outdoors. Exposing the LCD screen, the LCD finder or the lens to direct sunlight for long periods may cause malfunctions.

Do not get the camera wet

When taking pictures outdoors in the rain or under similar conditions, be careful not to get the camera wet. If moisture condensation occurs, see page 91 and follow the instructions on how to remove it before using the camera.



Back up recommendation

To avoid the potential risk of data loss, always copy (back up) data to a disk.

The pictures used in this manual

The photographs used as examples of pictures in this manual are reproduced images, and are not actual images shot using this camera.

Trademarks

- “Memory Stick,” , “MagicGate Memory Stick,” and , are trademarks of Sony Corporation.
- “MagicGate” and **MAGICGATE** are trademarks of Sony Corporation.
- Microsoft and Windows are registered trademarks of the U.S. Microsoft Corporation in the United States and other countries.
- Macintosh, Mac OS, and QuickTime, are trademarks or registered trademarks of Apple Computer, Inc.
- In addition, system and product names used in this manual are, in general, trademarks or registered trademarks of their respective developers or manufacturers. However, the TM or ® marks are not used in all cases in this manual.

How to hold the camera

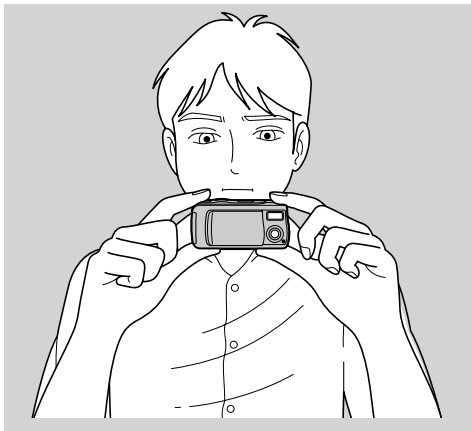

When shooting an image with the camera, be careful not to obstruct the flash or the lens with your fingers.

Table of contents

Before using your camera	6
How to hold the camera	7
Identifying the parts	10

Getting started

Preparing batteries.....	12
Charging the batteries.....	12
Inserting the batteries	16
Using your camera abroad.....	18
Turning on/off your camera	19
Setting the date and time	20

Shooting still images

Inserting and removing a “Memory Stick”	22
Setting the still image size.....	23
Basic still image shooting (using auto adjustment mode)	26
Using the self-timer.....	29
Selecting a flash mode	32
Shooting according to scene conditions	
– Scene Selection	34
Setting the distance to the subject – Focus preset	36
Shooting five images continuously – Burst.....	38
Adding special effects – Picture Effect	40

Viewing still images

Viewing still images on the LCD screen	42
Viewing single images.....	43
Viewing an index screen (four-image)	44
Choosing images to print – Print mark	46

Enjoying movies

Shooting movies	48
Viewing movies on the LCD screen	50

Deleting images

Deleting images	52
Formatting a “Memory Stick”	54

Copying images

Copying images to your computer	56
1 Installing the USB driver and application	58
2 Preparing your camera	67
3 Connecting your camera to your computer	68
4 Copying images	70
5 Viewing the images on your computer	75
For Macintosh users.....	76

Troubleshooting

Troubleshooting	78
Warnings and messages	85
Self-diagnostics display	86

Additional information

Menu items.....	87
Precautions.....	90
On “Memory Stick”	92
On Nickel Metal Hydride batteries	93
Specifications	94
LCD screen displays	96
Index	99

Identifying the parts

See the pages in parentheses for details of operation.

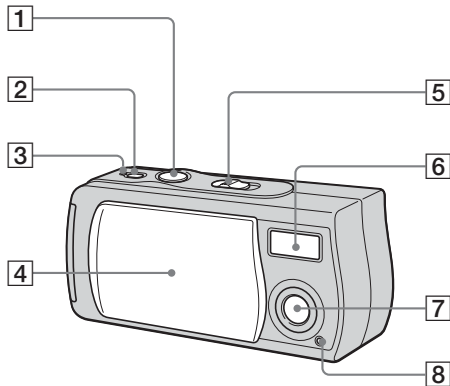

- 1 Shutter button** (27)
- 2 POWER button** (19)
- 3 POWER lamp** (19)
- 4 Lens cover**
- 5 Mode switch**
 - PLAY:** To view images (43)
 - STILL:** To shoot still images (26)
 - MOVIE:** To shoot movies (48)
- 6 Flash** (32)
- 7 Lens**
- 8 Self-timer lamp** (31)

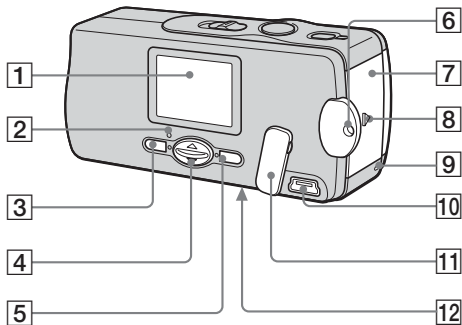
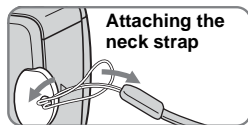

- 1 LCD screen
- 2 ⚡ Flash charge lamp (orange) (33)
- 3 MENU button
- 4 Control button
Menu on: ▲/▼
Menu off: ⚡/SCENE (32, 35)
- 5 EXEC button
- 6 Hook for neck strap
- 7 Battery/"Memory Stick" cover
- 8 OPEN button (16)
- 9 Access lamp (23)
- 10 USB jack (68)
- 11 USB jack cover
- 12 RESET button (bottom surface) (78)

How to use the control button and EXEC button

To change the current settings of the camera, bring up the menu, and use the control button to make the changes.

For each item, press MENU and press ▲/▼ on the control button to select the desired value, then press EXEC to make the setting. Press MENU, then the menu disappears from the LCD screen.



Preparing batteries

Use the following batteries in this camera.

Acceptable batteries

Size AAA Nickel Metal Hydride batteries (2)

- NH-AAA-DI (2) (supplied)
- NH-AAA-2DI twin-pack (recommended, not supplied)

Batteries that cannot be used

Manganese batteries, lithium batteries, Ni-Cd batteries, alkaline batteries

Charging the batteries

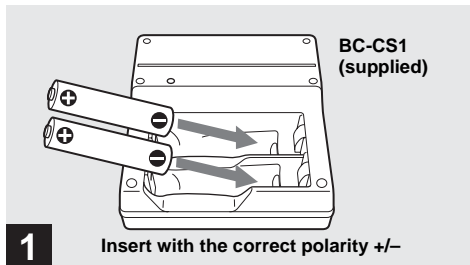

➔ Insert Nickel Metal Hydride batteries into the charger (supplied).

- Be sure to charge the Nickel Metal Hydride batteries supplied with your camera before using them.
- We recommend charging the batteries in an ambient temperature of between 10°C to 30°C (50°F to 86°F). If the batteries are charged in an environment where the temperature is outside that range, the batteries may not charge efficiently.
- Connect the battery charger to an easily accessible wall outlet (wall socket) close by. If some trouble occurs while using the charger, immediately shut off the power by disconnecting the plug out of the wall outlet (wall socket).

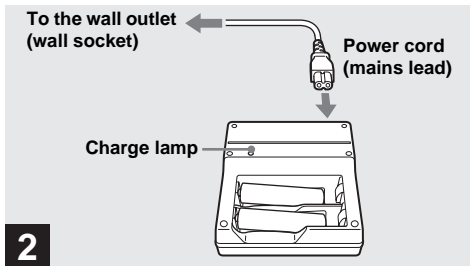

➔ **Connect the charger to a wall outlet (wall socket) using the power cord (mains lead).**

The charge lamp lights up when charging begins, and goes off when charging is completed. It takes about 13 hours to completely charge the batteries.

- When charging is finished, disconnect the power cord (mains lead) from the wall outlet (wall socket), and remove the Nickel Metal Hydride batteries from the charger.
- Always use the case supplied when transporting the Nickel Metal Hydride batteries. If the positive and negative terminals come into contact with metallic material and are shorted, the batteries could overheat or catch fire.



Charging the Nickel Metal Hydride batteries

- If the poles of the Nickel Metal Hydride batteries are dirty, the batteries may not charge properly. Occasionally clean the poles of the batteries and the terminals of the charger by wiping them with a dry cloth.
- At the time of purchase, or when the Nickel Metal Hydride batteries haven't been used for a long time, they may not fully charge. This is typical of this type of battery, and is not a malfunction. If this happens, several cycles of using the battery until it is completely drained and then charging the battery fully should correct the problem.
- Even when Nickel Metal Hydride batteries are not being used they lose their charge naturally over time. It is recommended that you recharge the batteries just before using them.
- If you recharge Nickel Metal Hydride batteries before fully using up the existing charge, the low battery warning may be displayed sooner than expected. This is called the "memory effect."* If this problem occurs, charging the batteries only after using up the existing charge will correct it.

* The "memory effect" – the situation in which the capacity of the battery is temporarily lowered.

Precautions to be observed when charging the batteries

- Do not charge any other batteries except Sony Nickel Metal Hydride batteries in the charger supplied with your camera. If you try to charge any other type of battery (e.g., manganese batteries, alkaline dry cells, or one-time lithium batteries) than the batteries specified, those batteries may leak, overheat, or explode, causing the danger of burns or other injuries.
- Be sure to charge both Nickel Metal Hydride batteries at the same time.
- When the batteries are charged, use them only in an environment where the temperature range is 10°C to 30°C (50°F to 86°F). Otherwise, there is a danger of leaks, explosions, excessive heat, fire, or electric shock.
- Do not charge fully charged Nickel Metal Hydride batteries again. Otherwise, there is a danger of leaks, explosions, excessive heat, fire, or electric shock.
- Do not peel off the external seals or damage the batteries. Never use batteries from which the seals have been partially or completely removed, or batteries that have been split in any way.



Charging time

Nickel Metal Hydride battery	Charging time
NH-AAA-DI × 2 (supplied)	Approx. 13 hours

This represents the time required to charge fully depleted Nickel Metal Hydride batteries using the supplied BC-CS1 charger in an environment where the ambient temperature is 25°C (77°F).





- It takes about 13 hours to completely charge the batteries. The charge lamp may remain lit longer than 13 hours, but this is not a malfunction.
- Do not remove the batteries while charging is still in progress. If you remove the batteries while charging is still in progress and then re-insert the batteries, the charging process will start over from the beginning.
- If you use the ACC-UNQ STAMINA “Super Quick charge” kit (not supplied), the batteries will charge faster.

Charging time

Size AAA Nickel Metal Hydride batteries
1 or 2 batteries: Approx. 1 hour 15 minutes
3 or 4 batteries: Approx. 2 hours 30 minutes

Battery remaining indicator (when using Nickel Metal Hydride batteries)

As the battery power decreases with use, the battery remaining indicator displays the amount of power remaining using the following symbols.

Battery remaining indicator	Battery remaining guidelines
	Sufficient power remaining
	Battery half full
	Battery low, recording/playback will stop soon.
	Change the batteries for fully charged ones, or charge these batteries. (Battery remaining indicator flashes.)

- If the LCD screen display is off, set [DISPLAY] in to [ON] with MENU and ▲/▼ on the control button to turn it on.
- Based on the conditions under which the camera is being used and the state of the charge, or on the environment, this information may not be correctly indicated.
- The battery remaining indicator is not displayed in USB connecting.

Inserting the batteries

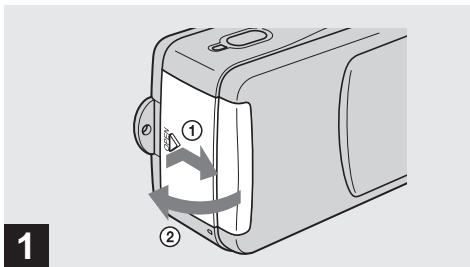

1

➔ Open the battery/“Memory Stick” cover.

Slide the cover in the direction of the arrow ① while pressing OPEN. The battery/“Memory Stick” cover opens in the direction the arrow ②.

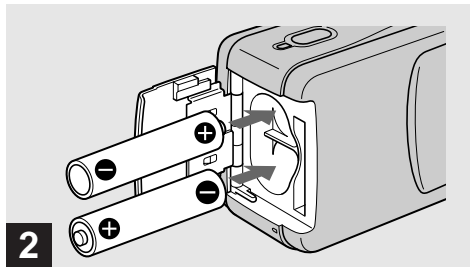

2

➔ Insert the batteries.

Match the +/- poles of the batteries to the +/- marks inside the battery case.

- From time to time, use a dry cloth to wipe any dirt off of the battery terminals and the contacts inside the battery/“Memory Stick” cover. Skin oil and other dirt on the battery terminals and contacts can significantly shorten the operating time provided by the batteries.

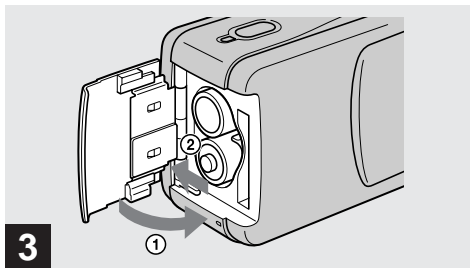

→ Close the battery/“Memory Stick” cover.

Close the battery/“Memory Stick” cover while holding the batteries in. Make sure the cover is closed securely.

To remove the batteries

Hold the camera with the battery/“Memory Stick” cover facing upward, open the cover, and remove the batteries.

- Be careful not to drop the batteries when opening or closing the battery/“Memory Stick” cover.

Battery life and number of images that can be recorded/viewed

The tables show the approximate battery life and the number of images that can be recorded/viewed with a fully charged batteries at a temperature of 25°C (77°F),  (no flash) and auto adjustment mode. But the remaining indicator will decrease in the following situations:

- The surrounding temperature is low
- The camera has been turned on and off many times
- [LCD LIGHT] is set to [ON]
- The battery power is low
- The battery capacity decreases as you use it more and more and as time passes (page 93).

Shooting still images*

Image size	NH-AAA-DI (2) (supplied)		
	LCD LIGHT	Battery life (min.)	No. of images
1280×960 (SXGA)**	ON	Approx. 60 min	Approx. 1600
	OFF	Approx. 70 min	Approx. 1800
640×480 (VGA)***	ON	Approx. 60 min	Approx. 1600
	OFF	Approx. 70 min	Approx. 1800

* Shooting at about 2.5-second intervals

** SXGA: Abbreviation of Super eXtended Graphics Array; indicates an image size of 1280×960

*** VGA: Abbreviation of Video Graphics Array; indicates an image size of 640×480



Viewing still images**

Image size	NH-AAA-DI (2) (supplied)	
	Battery life (min.)	No. of images
1280×960	Approx. 120	Approx. 2400
640×480	Approx. 120	Approx. 2400

** Viewing single images in order at about 3-second intervals with all indicators on and LCD LIGHT ON

Shooting movies***

	NH-AAA-DI (2) (supplied)	
	Battery life (min.)	
Continuous recording	LCD LIGHT ON	Approx. 60
	LCD LIGHT OFF	Approx. 70

***The maximum playing time is 15 seconds

- The battery life and number of images will be decreased when using the camera at low temperatures, using the flash or turning the power on/off repeatedly.

Power sources

You can use your camera in any country or area with the supplied battery charger within 100 V to 240 V AC, 50/60 Hz. Use a commercially available AC plug adaptor [a], if necessary, depending on the design of the wall outlet (wall socket) [b].

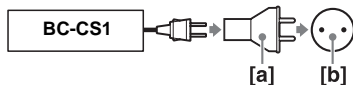

- Do not use an electronic transformer (travel converter), as this may cause a malfunction.

Turning on/off your camera

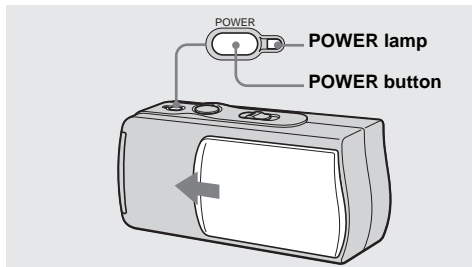

➔ Slide the lens cover in the direction of the arrow or press the POWER button.

When you open the lens cover or press the POWER button, the power is automatically on. The POWER lamp (green) lights up. When you turn on your camera for the first time, the DATE NOTATION screen appears on the LCD screen (page 20).

To turn off the power

Slide the lens cover in the opposite direction of the arrow or press the POWER button again. The POWER lamp goes out, and the camera turns off.

- If you open the lens cover too quickly, the camera might not turn on. If this happens, close the cover and then open it again more slowly.

Auto power-off function

If you do not operate the camera for about 3 minutes during shooting or viewing or when performing setup, the camera turns off automatically to prevent wearing down the battery. The auto power-off function also will not operate when a connector is plugged into the USB jack.



Setting the date and time

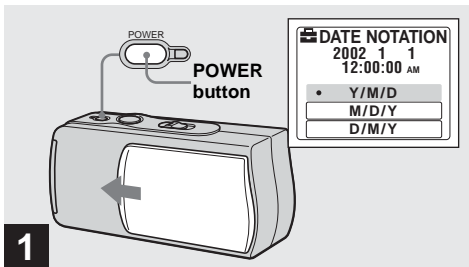

➔ Slide the lens cover in the direction of the arrow or press the **POWER** button to turn on the power.

The **POWER** lamp (green) lights up and the **DATE NOTATION** screen appears on the LCD screen.

- This operation is available no matter what position the mode switch is in.
- To change the date and time, press **MENU** and select [**DATE&TIME SET**] in [**CLOCK SET**] under [**⏸**] (page 89), then perform the procedure from step **3**.

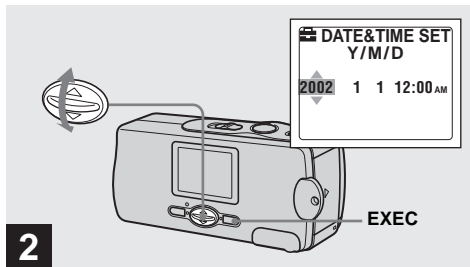

➔ Select the desired date display format with **▲/▼** on the control button, then press **EXEC**.

Select from [**Y/M/D**] (year/month/day), [**M/D/Y**] (month/day/year) or [**D/M/Y**] (day/month/year). Then **DATE&TIME SET** screen appears on the LCD screen.

- If the rechargeable button battery, which provides the power for saving the time data, is ever fully discharged (page 91), the **DATE NOTATION** screen will appear again. When this happens, reset the date and time, by starting from step **2**.

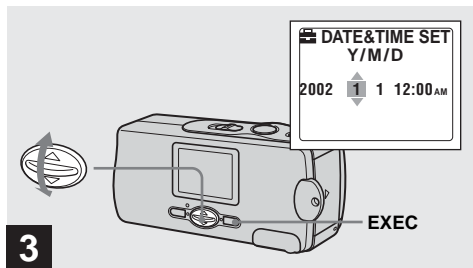

3 → Set the numeric value with ▲/▼ on the control button, then press EXEC.

The item to be set is indicated with ▲/▼.
After entering the number, ▲/▼ moves to the next item.
Repeat this step until all of the items are set.

- If you selected [D/M/Y] in step **2**, set the time on a 24-hour cycle.

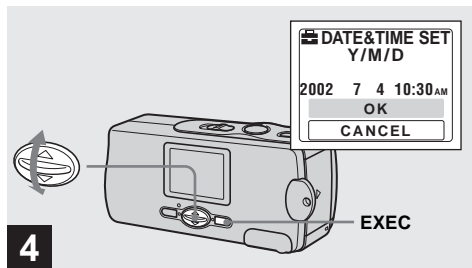

4 → Select [OK] with ▲/▼ on the control button, then press EXEC.

The date and time are entered and the clock starts to keep time.

- If you make a mistake, select [CANCEL] in step **4** to display the DATE NOTATION screen, then repeat the procedure from step **2**.



Inserting and removing a "Memory Stick"

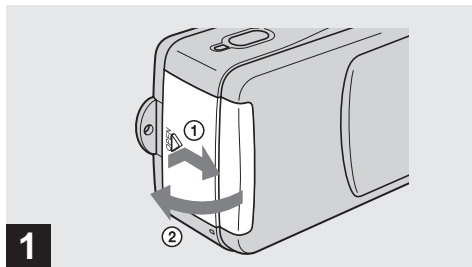

➔ Open the battery/"Memory Stick" cover.

Slide the cover in the direction of the arrow ① while pressing OPEN. The battery/"Memory Stick" cover opens in the direction the arrow ②.

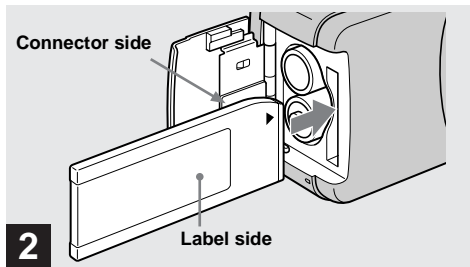

➔ Insert the "Memory Stick."

Holding the "Memory Stick" as shown in the illustration, insert it all the way in until it clicks.

- Push the "Memory Stick" all of the way in so that it is securely seated in the connector. If the "Memory Stick" is not inserted correctly, you may not be able to record or display images in the "Memory Stick."
- Be careful not to drop the batteries when opening or closing the battery/"Memory Stick" cover.

Setting the still image size

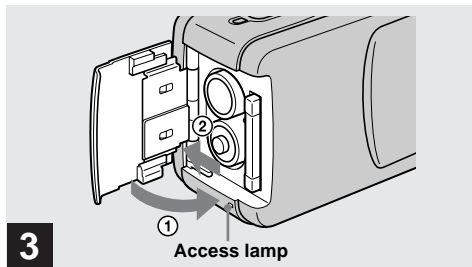

➔ Close the battery/“Memory Stick” cover.

To remove a “Memory Stick”

Open the battery/“Memory Stick” cover, then push the “Memory Stick” to pop it out.

- When the access lamp is lit up, it means that image data is being read or written. Never remove the “Memory Stick” or turn off the power at this time, as the data may be damaged.

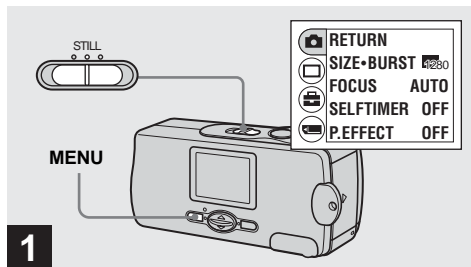

➔ Set the mode switch to **STILL**, and turn on the power, then press **MENU**.

The menu appears on the LCD screen.



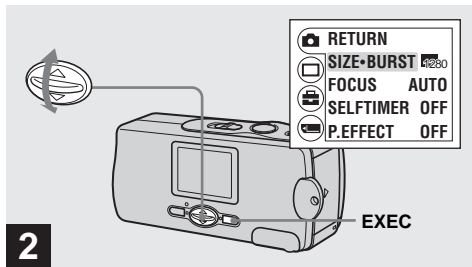

- ➔ Select [📷] with ▲/▼ on the control button, then press EXEC.
 Select [SIZE-BURST] with ▲/▼ on the control button, then press EXEC.

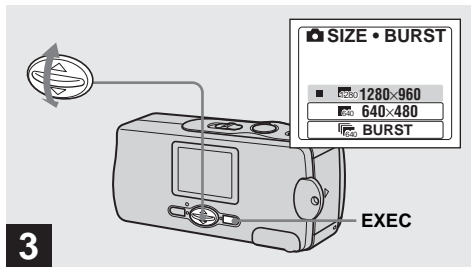

- ➔ Select the desired image size with ▲/▼ on the control button, then press EXEC.

The image size is set.
 When the setting is complete, press MENU so that the menu disappears from the LCD screen.

- The image size selected here is maintained even when the power is turned off.

Image size

You can choose the image size (number of pixels) according to the kind of images you want to shoot. Larger image sizes result in a larger data size, which means fewer images that you can record in a “Memory Stick.”

Choose an image size appropriate for the kind of images you want to shoot.

You can choose from the following table.

Image size	Usage
1280×960	Printing in postcard size
640×480	Attaching to e-mail

Number of images that can be saved in a “Memory Stick”

(Units: number of images)

Image size \ Capacity	1280×960	640×480
	8MB	23
16MB	45	160
32MB	93	325
64MB	187	655
128MB	375	1315

- Image size is the size when viewing the images on a personal computer. Images viewed on the LCD screen of the camera all appear the same size.
- The actual number of images may differ depending on the shooting conditions.
- The image size value (e.g., 1280×960) indicates the number of pixels.





Basic still image shooting (using auto adjustment mode)

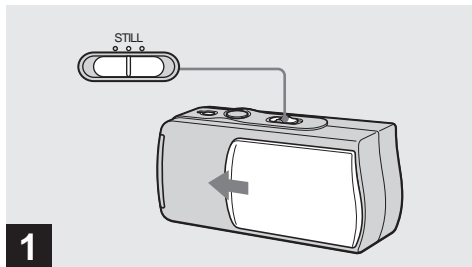

➔ **Set the mode switch to STILL, and slide the lens cover to turn on the power.**

- Still images are recorded in JPEG format.
- The exposure and focus are adjusted automatically at the factory setting.
- Clean the lens with a soft cloth if it is dirty (page 90).

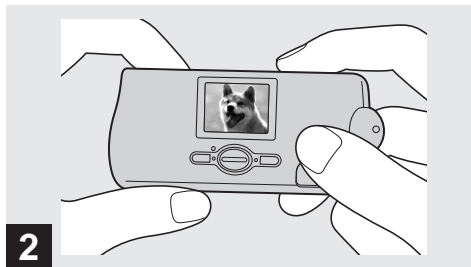

➔ **Hold the camera steadily with both hands and position the subject in the center of the LCD screen.**

Do not cover the lens or flash with your fingers.

- When recording outdoors during clear weather or under other intense light, undesired light (ghosting) may enter the screen. If this happens, shade the lens with your hand or other object while recording.
- The exposure and focus are adjusted to the center of the LCD screen.

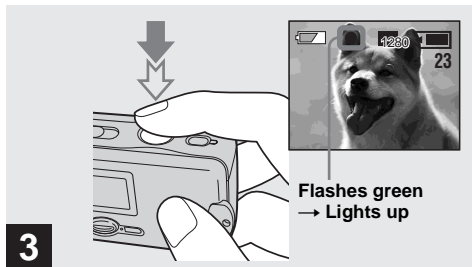

➔ **Press and hold the shutter button halfway down.**

The beep sounds but the image is not yet recorded. When the AE/AF lock indicator changes from flashing to lighted up, the camera is ready for shooting.

- If you release the shutter button, the recording will be canceled.
- The minimum focal distance to the subject is 10 cm (4 inches).

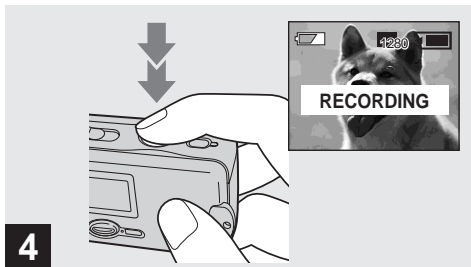

➔ **Press the shutter button fully down.**

The beep sounds. “RECORDING” appears on the LCD screen, and the image will be recorded in the “Memory Stick.” When “RECORDING” disappears, you can shoot the next image.

- When operating the camera using batteries, if you do not operate the camera for about 3 minutes during recording or playback, the camera turns off automatically to prevent wearing down the batteries (page 19).



Auto Focus

When you try to shoot a subject that is difficult to focus on, the AE/AF lock indicator changes to flashing slowly.

The Auto Focus function may have difficulty working under the following conditions. In such cases, release the shutter button, then recompose the shot and focus again. If the Auto Focus function can still not bring the subject into focus, use the Focus Preset function (page 36).

- The subject is distant from the camera and dark.
- The contrast between the subject and its background is poor.
- The subject is seen through glass, such as a window.
- A fast-moving subject.
- The subject reflects or has a lustrous finish, such as a mirror or a luminous body.
- A flashing subject.

LCD light

You can use [LCD LIGHT] under [] with MENU and ▲/▼ on the control button to turn the LCD light on and off. This is useful for extending the battery life.

- This camera is equipped with a reflective-type LCD screen that allows you to see the LCD screen even when the LCD light is turned off, as long as there is some ambient illumination.
- Even if the LCD light setting is “off,” the LCD light will turn on when menu operations are being performed. When the menu operation is completed, the LCD light will turn off again.

LCD screen display during shooting

You can use [DISPLAY] under [] with MENU and ▲/▼ on the control button to turn the display on and off. This is useful when recording under conditions where it is difficult to check the image on the LCD screen.

When [DISPLAY] is [ON]

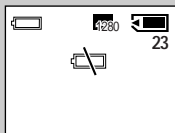

(Displays all indicators that can be displayed)



When [DISPLAY] is [OFF]



(Displays warnings only)

- For detailed descriptions of the indicators, see page 96.
- Indicators on the LCD screen are not recorded.

Using the self-timer

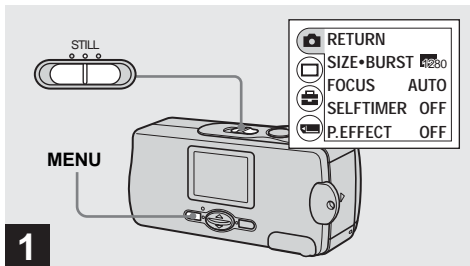

➔ **Set the mode switch to STILL, and press MENU.**

The menu appears on the LCD screen.

- You can also carry out this operation when the mode switch is set to MOVIE.



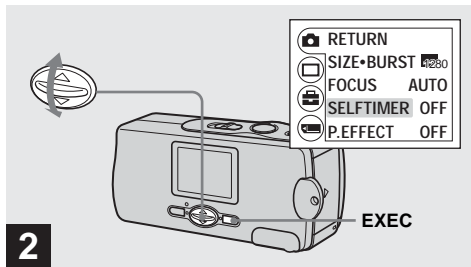

- ➔ Select [📷] with ▲/▼ on the control button, then press EXEC.
 Select [SELFTIMER] with ▲/▼ on the control button, then press EXEC.

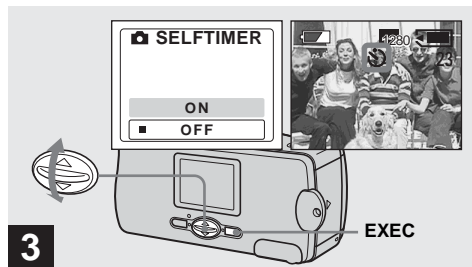

- ➔ Select [ON] with ▲/▼ on the control button, then press EXEC.

When you press MENU, the menu disappears.
 The ⌚ (self-timer) indicator appears on the LCD screen.

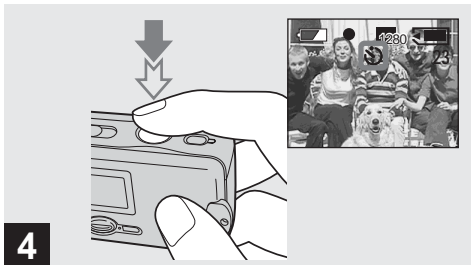

➔ **Center the subject in the LCD screen, and press and hold the shutter button halfway down.**

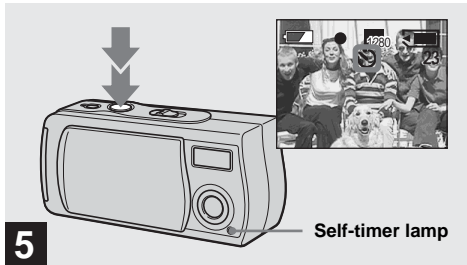

➔ **Press the shutter button fully down.**

The self-timer lamp (page 10) flashes in red and the beep sounds. The image will be shot after approximately 10 seconds.

To cancel the self-timer in the middle of the operation

Close the lens cover and turn off the power.

- If you press the shutter button while standing in front of the camera, the focus and the exposure may not be correctly set.



Selecting a flash mode

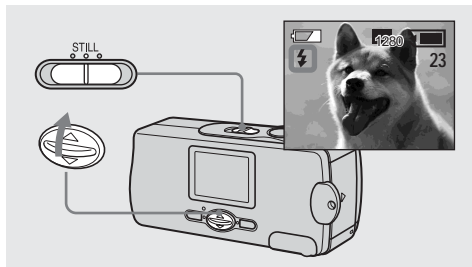

➔ **Set the mode switch to STILL, and press ▲ (⚡) on the control button repeatedly to select a flash mode.**



Each time you press ▲ (⚡), the indicator changes as follows:

No indicator (Auto): Based on the lighting conditions, the camera will decide if there is enough light, and will use the flash accordingly (factory setting).

👁 (Red-eye reduction): Flash mode is set to Auto, and the red-eye reduction operates if the flash strobos.

⚡ (Forced flash): The flash strobos regardless of the surrounding brightness.

🚫 (No flash): The flash does not strobe.

- You cannot use the flash in the Burst mode.
- If the menu is currently displayed, press MENU first so that the menu disappears.
- When using the Auto,  (Red-eye reduction) or  (Forced flash) mode, you may notice some noise in the image when you look at the LCD screen in a dark place, but this will have no effect on the shot image.
- While charging the flash, the flash charge lamp flashes. After the charging is complete, the lamp goes out.
- When you press the shutter button halfway down while the flash is strobing, the flash charge lamp turns on.

To reduce the red-eye phenomenon when shooting live subjects

When the red-eye reduction is selected,  indicator appears on the LCD screen, and the flash pre-strobes before shooting to reduce the red-eye phenomenon.



- Red-eye reduction may not produce the desired effects depending on individual differences, the distance to the subject, if the subject does not see the pre-strobe, or other conditions.





Shooting according to scene conditions - Scene Selection

Soft snap mode



Illumination snap mode



Vivid nature mode



When shooting night scenes, shooting portraits, or shooting landscapes, use the modes listed below to improve the quality of your images.

Soft snap mode

The soft snap mode lets you shoot skin colors in brighter and warmer tones for more beautiful pictures. In addition, the soft focus effect creates a gentle atmosphere for portraits of people, flowers, etc.

Illumination snap mode

The illumination snap mode lets you capture beautiful images of both subjects and night scene backgrounds at the same time. In addition, the cross filter effect enhances street lamps or other lights with cross-shaped rays.

- The flash strobos in  (Red-eye reduction) mode, and the recommended subject distance is 0.5 to 1.2 m.
- When set the focus to [AUTO], the focus is adjusted to approximately 1 m to ∞ (infinite). To record subjects closer than 1 m, use the Focus Preset (page 36).

Vivid nature mode

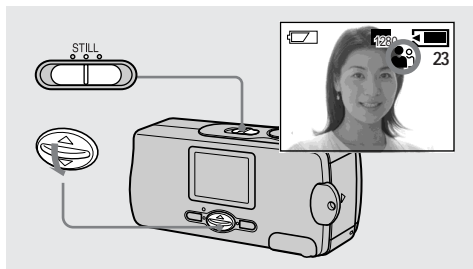

The vivid nature mode enhances blues and greens such as the sky, ocean and mountains, letting you shoot natural landscapes with vivid, striking colors.

- The focus setting changes to [∞].
- The flash cannot be used in this mode.
- When set the focus to [AUTO], the focus is adjusted to telephoto.



➔ Set the mode switch to **STILL**, and press ▼ (SCENE) on the control button repeatedly to select a desired mode.

Each time you press ▼ (SCENE), the indicator changes as follows:

 (Soft snap mode) →
  (Illumination snap mode)
 →  (Vivid nature mode) → No indicator (Auto)

- If the menu is currently displayed, press MENU first so that the menu disappears.
- To cancel Scene Selection, press ▼ (SCENE) repeatedly until the indicator disappears.
- You cannot use the Scene Selection in shooting movies.





Setting the distance to the subject – Focus preset

 0.5 m



 0.2m



When shooting an image using a preset distance to the subject, or when shooting a subject through a net or window glass, it is difficult to achieve a proper focus using the auto focus function. The Focus preset function is useful in these cases.

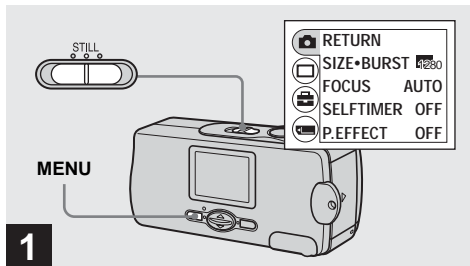

➔ **Set the mode switch to STILL, and press MENU.**

The menu appears on the LCD screen.

- You can also carry out this operation when the mode switch is set to [MOVIE].

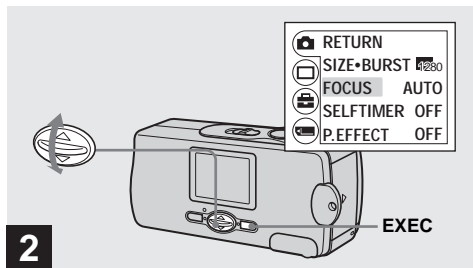

- 2**
- ➔ Select [CAMERA] with ▲/▼ on the control button, then press EXEC.
 Select [FOCUS] with ▲/▼ on the control button, then press EXEC.

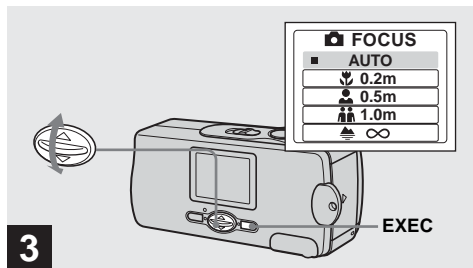

- 3**
- ➔ Select the desired focus setting with ▲/▼ on the control button, then press EXEC.

You can select from the following distance settings: AUTO (No indicator), 0.2 m, 0.5 m, 1.0 m, and ∞ (infinity)

To reactivate auto focusing

Select [AUTO] in step **3**.

- Focus setting information is approximate, and should be used as a reference.





Shooting five images continuously - Burst

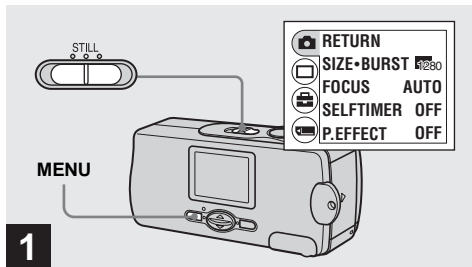

➔ Set the mode switch to **STILL**, and press **MENU**.

The menu appears on the LCD screen.

- You can shoot up to five frames in succession by holding down the shutter button. If you release the shutter button before all five frames are shot, the camera stops shooting as soon as you release the button.

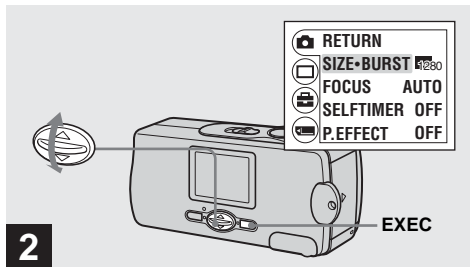

➔ Select [] with ▲/▼ on the control button, then press **EXEC**.
Select [**SIZE-BURST**] with ▲/▼ on the control button, then press **EXEC**.

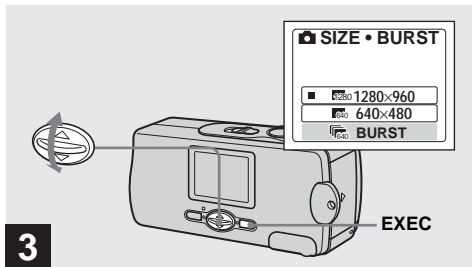

3 → Select [BURST] with ▲/▼ on the control button, then press EXEC.

Press MENU so that the menu disappears from the LCD screen.

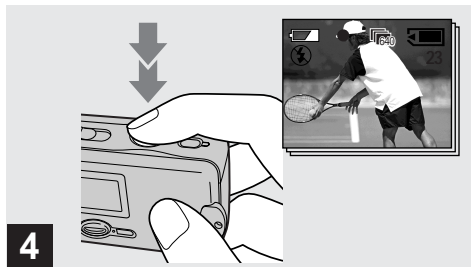

4 → Press the shutter button halfway down, then hold the shutter button fully down.

Up to five images are recorded as long as you hold down the shutter button.
The images are recorded in 640×480 size.

- You cannot use the flash in this mode.
- If you release the shutter button before the camera records five images, only the images that were shot while the shutter button was held down are recorded.
- The recording interval is approximately 0.5 seconds.



Adding special effects - Picture Effect

You can digitally process images to obtain special effects.

NEG. ART



The color and brightness of the picture are reversed as in a negative.

SEPIA



The picture is sepia-toned like an old photograph.

B&W



The picture is monochrome (black and white).

SOLARIZE



The light contrast is clearer and the picture looks like an illustration.

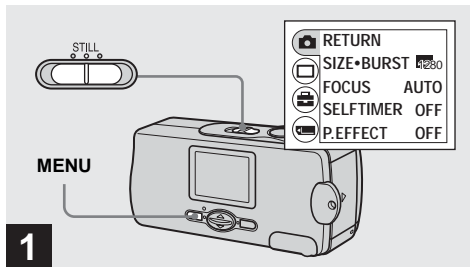

➔ Set the mode switch to **STILL**, and press **MENU**.

The menu appears on the LCD screen.

- You can also carry out this operation when the mode switch is set to **MOVIE**.

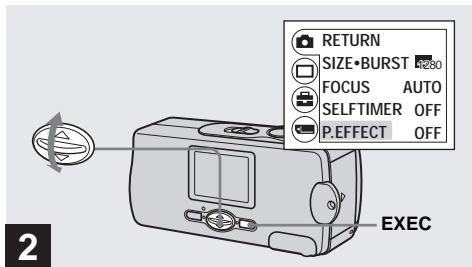

- ➔ Select [] with ▲/▼ on the control button, then press EXEC.
 Select [P.EFFECT] with ▲/▼ on the control button, then press EXEC.

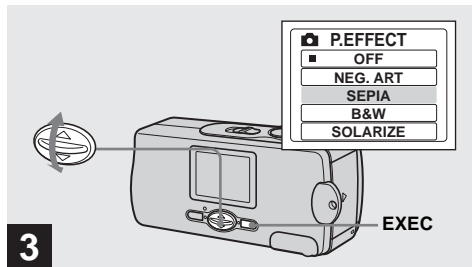

- ➔ Select the desired mode with ▲/▼ on the control button, then press EXEC.

To cancel Picture Effects
 Select [OFF] in step **3**.





Viewing still images on the LCD screen

Single (single-image) screen



Index (four-image) screen



You can view images shot with your camera almost immediately on the LCD screen. You can select the following two methods for viewing images.

Single (single-image) screen

You can view one image at a time, displayed over the entire screen.

Index (four-image) screen

Four images are displayed simultaneously in separate panels on the screen.

- For a detailed description of the screen indicators, see page 98.
- For details on the movies, see page 48.
- Images that are not VGA or SXGA size are displayed as thumbnails.

Viewing single images

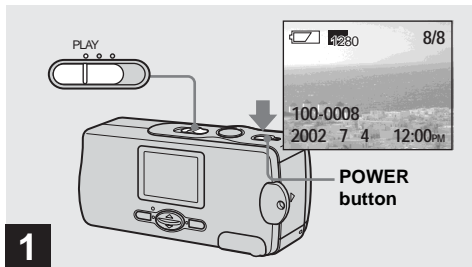

➔ Set the mode switch to **PLAY**, and press the **POWER** button to turn on the power.

The last image you shot appears on the LCD screen.

- If you close the lens cover while viewing images, the power is off.



➔ Select the desired still image with **▲/▼** on the control button.

- ▲ : To display the preceding image
- ▼ : To display the next image



Viewing still images

Viewing an index screen (four-image)

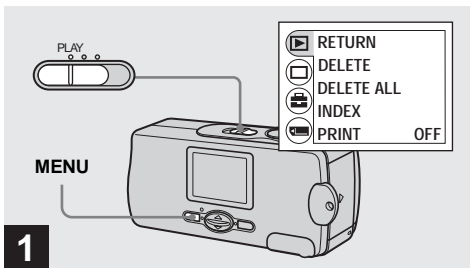

➔ Set the mode switch to **PLAY**, and press **MENU**.

The menu appears on the LCD screen.

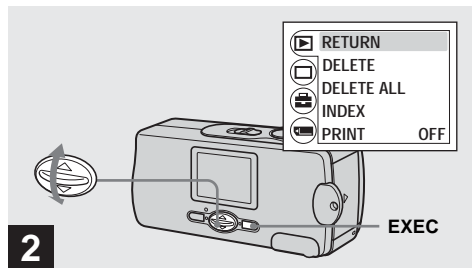

➔ Select [**▶**] with **▲/▼** on the control button, then press **EXEC**.

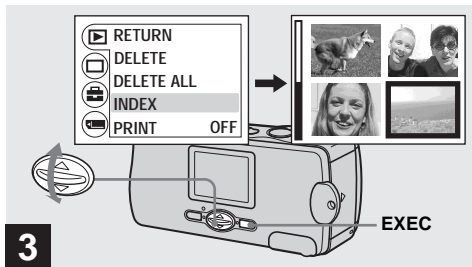

➔ **Select [INDEX] with ▲/▼ on the control button, then press EXEC.**

The display switches to the **Index (four-image) screen**.

To display the next (previous) index screen

Press ▲/▼ on the control button to move the yellow border.

To return to the single-image screen

Select [SINGLE] in step **3**. When 4 frames are displayed, press EXEC to display the single image shown with the yellow border.





Choosing images to print – Print mark

You can mark a print mark on still images shot with your camera. This mark is convenient when you have images printed at a shop that conforms with the DPOF (Digital Print Order Format) standard.

- You cannot mark movies.

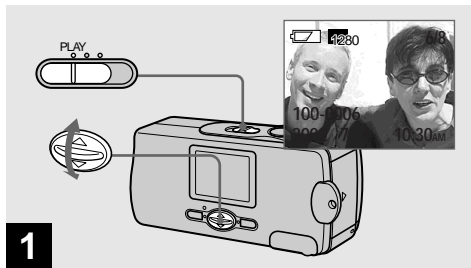

- ➔ **Set the mode switch to PLAY, and display the image you want to print with ▲/▼ on the control button.**

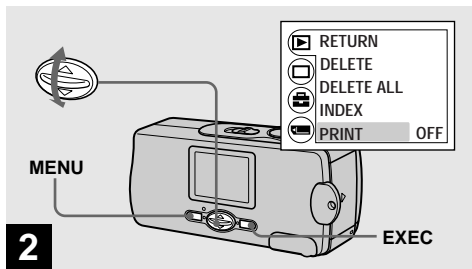

- ➔ Press MENU, and select [▶] with ▲/▼ on the control button, then press EXEC. Select [PRINT] with ▲/▼ on the control button, then press EXEC.

To mark the print mark in index-image mode

For details, see page 44 and switch to index screen.

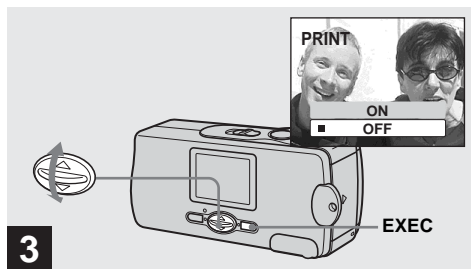

- ➔ Select [ON] with ▲/▼ on the control button, then press EXEC.

When you press MENU, the menu disappears and the  (print) mark is marked on the displayed image.

To unmark the print mark

Select [OFF] in step **3**. The  (print) mark disappears.



Shooting movies

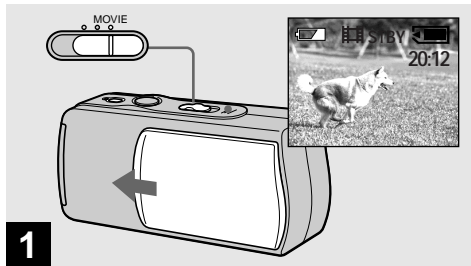

➔ **Set the mode switch to MOVIE, and open the lens cover to turn on the power.**

- Movies are recorded in MPEG format.
- Sound cannot be recorded in movies.

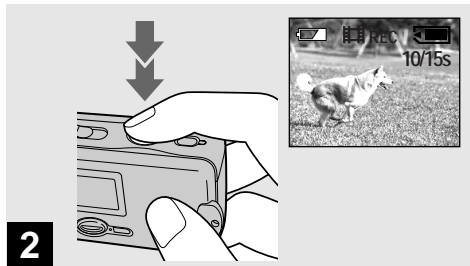

➔ **Press the shutter button fully down.**

“REC” appears on the LCD screen and the camera starts recording the image. The maximum recording time is 15 seconds.

- The focus setting can set the focus at any distance from approximately 1.0 m to ∞ (infinity). To shoot a subject at a closer distance than 1.0 m, use the Focus Preset function. (page 36)
- Recording stops when the “Memory Stick” is full.
- For details on the recording time for each image size, see page 50.
- The flash does not function when shooting movies.

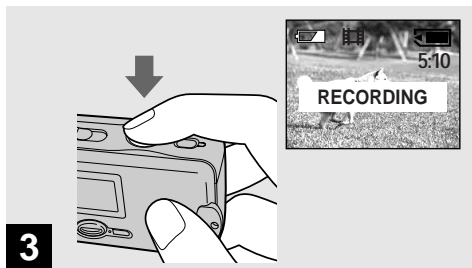

➔ **To stop recording, press the shutter button fully again.**

Indicators during shooting

Indicators on the LCD screen are not recorded. You can use [LCD LIGHT] under [] with MENU and ▲/▼ on the control button to turn the LCD light on and off. This is useful for extending the battery life. For detailed descriptions of the indicators, see page 97.

To set the distance to the subject

Set the mode switch to MOVIE and follow the procedure on page 36.

To use the self-timer

Set the mode switch to MOVIE and follow the procedure on page 29.



Shooting time

The shooting time is different, depending on the capacity of the “Memory Stick.” Refer to the following chart when you choose a “Memory Stick.”

- The maximum shooting time is 15 seconds per recording.
- The shooting time may vary, depending on the shooting conditions.
- For numbers of still images that can be recordable, see page 25.

(Units: minutes)

	160×112
8MB	5 min. 20 sec.
16MB	10 min. 40 sec.
32MB	21 min. 40 sec.
64MB	45 min.
128MB	90 min.

Viewing movies on the LCD screen

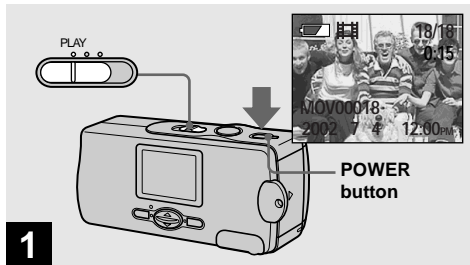

➔ Set the mode switch to **PLAY**, and press the **POWER** button to turn on the power.

The last image you shot appears on the LCD screen.

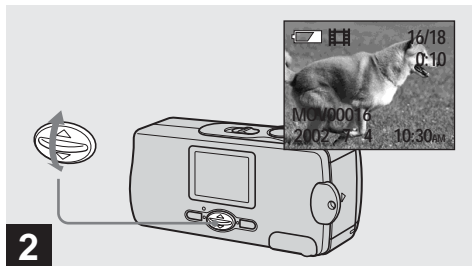

2 → Select the desired movies with ▲/▼ on the control button.

- ▲ : To display the preceding image
- ▼ : To display the next image

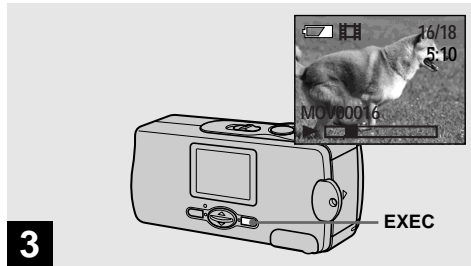

3 → Press EXEC.

The movie is played back.

To stop playback

Press EXEC.

Indicators during viewing movies

Indicators on the LCD screen are not recorded. You can use [LCD LIGHT] under [] with MENU and ▲/▼ on the control button to turn the LCD light on and off. This is useful for extending the battery life. For detailed descriptions of the indicators, see page 98.



Deleting images

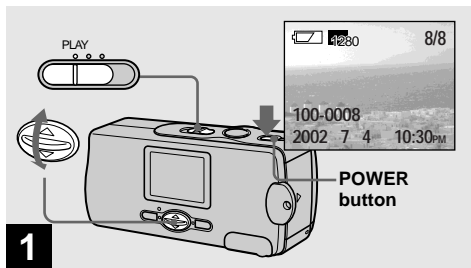

- ➔ Set the mode switch to PLAY, and press the POWER button to turn on the power. Press ▲/▼ on the control button to select the image you want to delete.

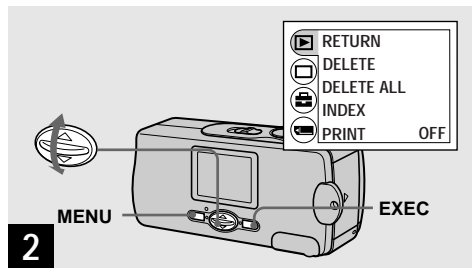

- ➔ Press MENU and select [▶] with ▲/▼ on the control button, then press EXEC.

To delete the image in index-image screen
For details, see page 44 and switch to index screen.

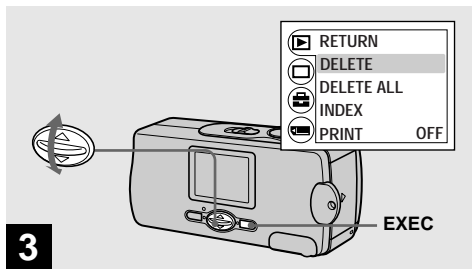

➔ Select [DELETE] with ▲/▼ on the control button, then press EXEC.

The image has not yet been deleted at this point.

To delete all the images

Select [DELETE ALL] in step **3**.

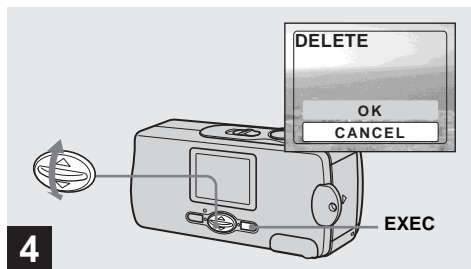

➔ Select [OK] with ▲/▼ on the control button, then press EXEC.

“MEMORY STICK ACCESS” appears on the LCD screen. When this message disappears, the image has been deleted.

To cancel deleting

Select [CANCEL] in step **4**.



Formatting a "Memory Stick"

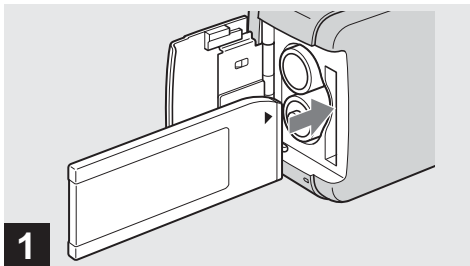

➔ Insert the "Memory Stick" you want to format into the camera.

Do not open the battery/"Memory Stick" cover while formatting the "Memory Stick." Doing so could damage the "Memory Stick."

- The term "formatting" means preparing a "Memory Stick" to record images; this process is also called "initialization." The "Memory Stick" provided with this camera, and those available commercially, are already formatted, and can be used immediately. **When you format a "Memory Stick," be aware that all of the images in the "Memory Stick" will be permanently deleted.**

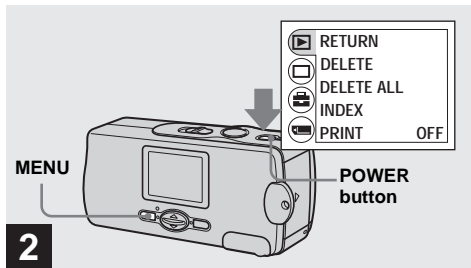

➔ Press the POWER button to turn on the power, and press MENU.

The menu appears on the LCD screen.

- This operation is available no matter what position the mode switch is in.

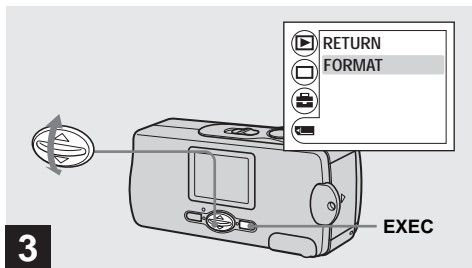

- ➔ Select [] with ▲/▼ on the control button, then press EXEC. Select [FORMAT] with ▲/▼ on the control button, then press EXEC.

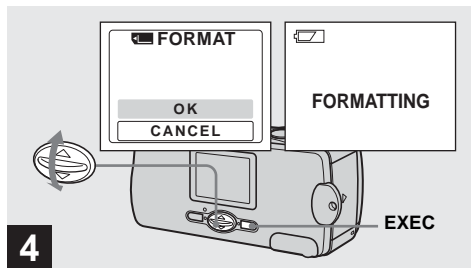

- ➔ Select [OK] with ▲/▼ on the control button, then press EXEC.

The “FORMATTING” message appears. When this message disappears, the format is complete.

To cancel formatting

Select [CANCEL] in step 4.

- When you format a “Memory Stick,” be sure to remain sufficient power, as “FORMAT ERROR” may occur.





Copying images to your computer

Follow the steps below to copy the images you have shot to your computer.

Steps required by your OS (Operating System)

OS	Steps
Windows 98/98SE/2000/Me	Steps 1 to 5 (pages 58, 67, 68, 70 and 75)
Windows XP	Steps 5 of 1 to 5 (pages 58, 61, 67, 68, 72, and 75)
Mac OS 8.5.1/8.6/9.0/9.1/9.2, Mac OS X (v10.0/v10.1)	Page 76

- Some step may be unnecessary depending on your OS.
- After the USB driver or applications are installed, step **1** is unnecessary.

Recommended computer environment

Recommended Windows environment

OS: Microsoft Windows 98, Windows 98SE, Windows 2000 Professional, Windows Millennium Edition, Windows XP Home Edition, or Windows XP Professional

The above OS must be installed at the factory. Operation is not assured in an environment upgraded to the operating systems described above.

CPU: MMX Pentium 200 MHz or faster

USB connector: Provided as standard

Display: 800 × 600 dots or more

High Color (16-bit color, 65,000 colors) or more

Recommended Macintosh environment

OS: Mac OS 8.5.1, 8.6, 9.0, 9.1, 9.2, or Mac OS X (v10.0/v10.1)

The above OS must be installed at the factory. For the following models, update your OS to Mac OS 9.0 or 9.1.

- iMac with Mac OS 8.6 installed at the factory, and a slot loading type CD-ROM drive
- iBook or Power Mac G4 with the Mac OS 8.6 installed at the factory

USB connector: Provided as standard

Display: 800 × 600 dots or more
32,000-color mode or more

- If you connect two or more USB equipment to a single computer at the same time, some equipment, including your camera, may not operate depending on the type of USB equipment.
- Operations are not guaranteed when using a USB hub.
- Operations are not guaranteed for all the recommended computer environments mentioned above.

USB mode

There are two modes for a USB connection, [NORMAL] and [PTP] modes. The factory setting is the [NORMAL] mode. This section describes the USB connection using the [NORMAL] mode.

When the camera is connected to your computer via a USB cable, the camera can draw its power from your computer. (USB Bus Powered)

Communication with your computer

When your computer resumes from the suspend or sleep mode, communication between your camera and your computer may not recover at the same time.

When a USB connector is not provided on your computer

When neither a USB connector nor a “Memory Stick” slot is provided, you can copy images using an additional device. See the Sony Website for details.
<http://www.sony.net/>





1 Installing the USB driver and application

98 2000 XP
98SE Me

Contents of the CD-ROM

■ USB driver

This driver is needed in order to connect the camera to a PC.

■ Image Transfer (for Windows users only)

This application is used to easily transfer images from the camera to a computer.

■ ImageMixer

This application is used to display and edit images that are stored in a computer.

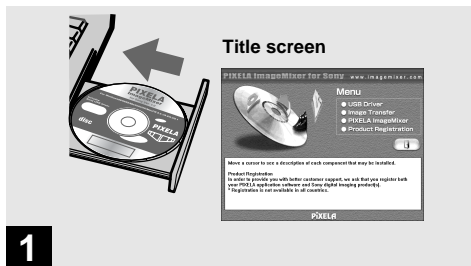

1 → Start up your computer, and insert the supplied CD-ROM into the CD-ROM drive.

Do not connect your camera to your computer at this time.

The title screen appears. If it does not appear, double-click  (My Computer) → [ImageMixer] in that order.

- This section describes how to establish a USB connection using Windows Me as an example. The required operations may differ depending on your OS.
- **Close down all applications running on the computer before installing the driver.**
- When using Windows XP or Windows 2000, log on as Administrators.
- The display settings should be 800 × 600 dots or more and High Color (16-bit color, 65,000 colors) or more. When set to less than 800 × 600 dots or 256 colors or less, the install title screen does not appear.



→ **Click [USB Driver] on the title screen.**

The “InstallShield wizard” screen appears.

- When using Windows XP, you need not install the USB driver. Proceed to step **5**.



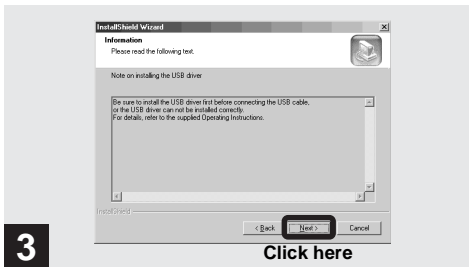

➔ Click [Next]. When the “Information” screen appears, click [Next].

The USB driver installation starts. When the installation is completed, the screen informs you of completion.



➔ Click [Yes, I want to restart my computer now], then click [Finish].

The installation is completed. Your computer restarts.



- ➔ **Click [Image Transfer] on the title screen.**
Select [English] then click [OK].

The “Welcome to the InstallShield Wizard” screen appears.

- You can use the “Image Transfer” software to copy images to your computer automatically when you connect the camera to your computer with the supplied USB cable.
- The USB driver is needed in order to use “Image Transfer”. If the necessary driver is not already installed on your computer, a screen that asks if you want to install the driver will appear. Follow the instructions that appear on the screen.

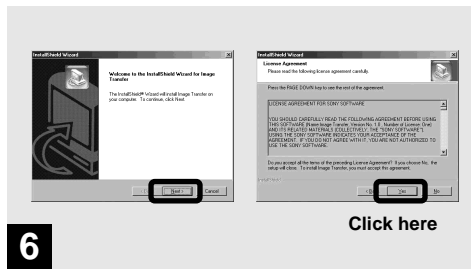

- ➔ **Click [Next].** When “Agreement” screen appears, click [Next].

Read the agreement carefully. You must accept the terms of the agreement in order to proceed with installation.





➔ Click [Next].

The installation starts.

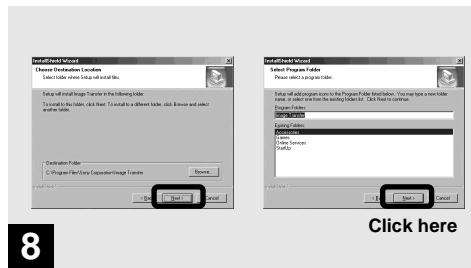

➔ Select the folder to be installed, then click [Next].

Select the program folder, then click [Next].



➔ **Confirm if the checkbox is checked on the “Image Transfer Settings” screen, then click [Next].**

The USB driver installation starts. When the installation is completed, the screen informs you of completion.



➔ **Click [Finish].**

The “InstallShield Wizard” screen closes. If you wish to continue with the installation of “ImageMixer,” select “No” and then follow the procedure that begins on page 64.



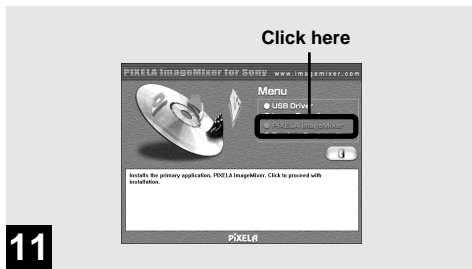

11

➔ Click [PIXELA ImageMixer for Sony] at the title screen.

The “Choose Setup Language” screen appears.

- You can use the “PIXELA ImageMixer for Sony” software to copy, view and edit images. For details, see the software’s help files.



12

➔ Select [English] then click [OK].

The “Welcome to the InstallShield Wizard” screen appears.



➔ **Follow instructions on each succeeding screen.**

When installation is complete, the “Read Me” text appears. Read the text, then close the window by clicking  at the upper right corner of the screen. After that, click [Finish] in the install screen to close the install screen.

- If DirectX8.0a or a later version is not installed in your computer, the “Information” screen appears.

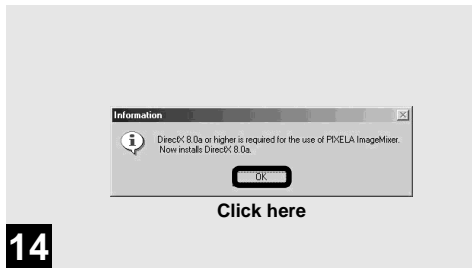

➔ **Click [OK].**

The “Microsoft DirectX8.0a Setup” screen appears.

- When using Windows XP, you need not install DirectX. Restart your computer and proceed to page 66.
- You do not need to install “DirectX” again if “DirectX Ver. 8.0a” or later is already installed in your computer.



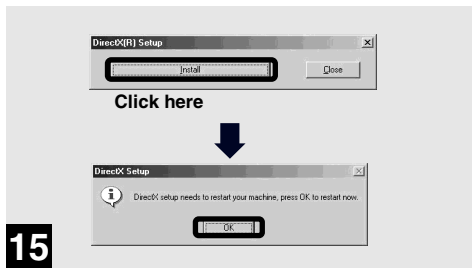

➔ Click [Install] at the “DirectX(R) Setup” screen, then when the “DirectX Setup” screen appears, click [OK].

DirectX installation starts. When installation is complete, your computer restarts.

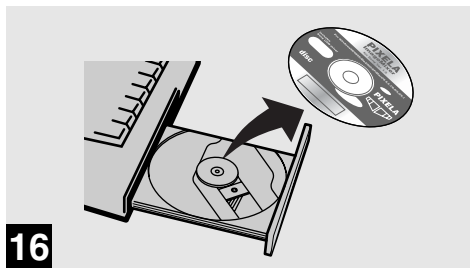

➔ Remove the CD-ROM.

Then, you can establish the USB connection.



2 Preparing your camera

98	2000	XP
98SE	Me	

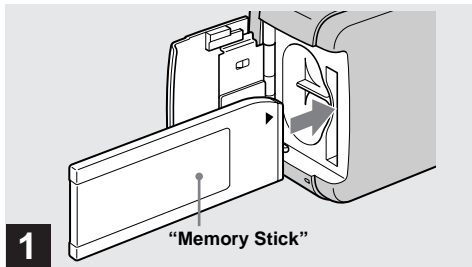

➔ Insert the "Memory Stick" with the images you want to copy into the camera.

- For further details on the "Memory Stick", see page 22.
- When your camera is connected to a computer, it draws power from the computer side. Removing the Nickel Metal Hydride batteries before connecting the camera is recommended in order to prevent battery deterioration.

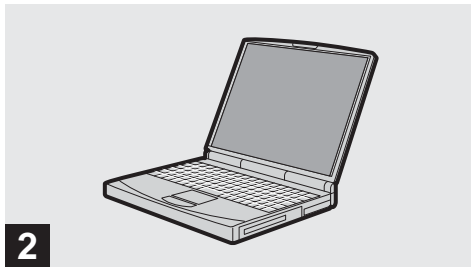

➔ Turn on your computer.





3 Connecting your camera to your computer

98	2000	XP
98SE	Me	

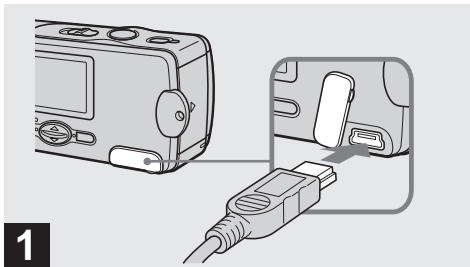

1

➔ Open the jack cover, and connect the supplied USB cable to your camera.

- Operations are not guaranteed when using a USB hub.

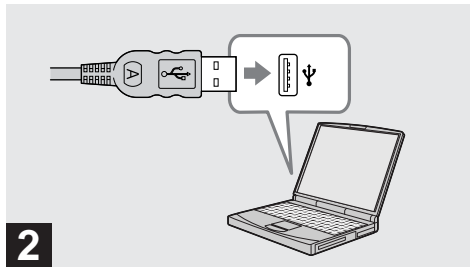

2

➔ Connect the other end of the USB cable to your computer.

The camera is on.

- Even if there are no batteries in the camera, most computers that are recommended for use with this camera can supply power to the camera through the USB connection. (USB Bus Powered)
- When using a desktop computer, connect the USB cable to the USB connector on the rear panel.
- When using Windows XP, the copy wizard automatically appears on the desktop. Proceed to page 72.



3



“USB MODE: NORMAL ” appears on the LCD screen. When a USB connection is established for the first time, your computer automatically runs the used program to recognize your camera. Wait for a while.

- If “USB MODE: NORMAL” is not shown in step **3**, confirm that [USB] is set to [NORMAL] in  (page 89).
- In USB mode, the POWER button, lens cover and other controls on the camera do not function.

Disconnecting the USB cable from your computer or removing the “Memory Stick” from your camera during USB connection

When the access lamp is lit up, it means that image data is being read or written. Never remove the “Memory Stick” or disconnect the USB cable at this time, as the data may be damaged.

For Windows 2000, Me, or XP users

- 1 Double-click  on the tasktray.
- 2 Click , then click [Stop].
- 3 Confirm the device on the confirmation screen, then click [OK].
- 4 Click [OK].
This step is unnecessary for Windows XP users.
- 5 Disconnect the USB cable or remove the “Memory Stick.”

For Windows 98 or 98SE users

Do only step **5** above.



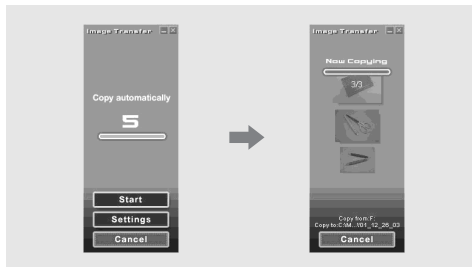

“Image Transfer” launches and the images are automatically copied to the computer. When copying is complete, “ImageMixer” automatically launches and a list of images appears.

- Normally “Image Transfer” and “Date” folders are created inside the “My Documents” folder, and all of the image files recorded with your camera are copied into these folders.
- You can change the “Image Transfer” settings at the SETUP screen.

Copying images without using “Image Transfer”

If you do not set to launch “Image Transfer” automatically, you can copy images as following procedure.

1 Double-click [My Computer], then double-click [Removable Disk].

The contents of the “Memory Stick” inserted in your camera appear.

- This section describes an example of copying images to the “My Documents” folder.
- When the “Removable Disk” icon is not shown, see page 71.
- When using Windows XP, see page 72.

2 Double-click [DCIM], then double-click [100MSDCF].

The “100MSDCF” folder opens.







- The “100MSDCF” folder contains the still image files you shot using your camera.
- The folder names vary depending on the type of images they contain (page 74).

3 Drag and drop the image files into the “My Documents” folder.

The image files are copied to the “My Documents” folder.

- When you try to copy an image to a folder in which an image with the same file name is stored, the overwrite confirmation message appears. When you want to overwrite the existing image with the new one, click [Yes]. In this time, the original one is deleted. When you do not want to overwrite it, click [No], then change the file name.

When a removable disk icon is not shown

- 1 Right-click [My Computer], then click [Properties]. The “System Properties” screen appears.
- 2 Confirm if other devices are already installed.
 - ① Click [Device Manager].
 - ② Double-click [ Other Devices].
 - ③ Confirm if there is a “ Sony DSC” or “ Sony Handycam” with a  mark.
- 3 If you find either of the devices above, follow the steps below to delete them.
 - ① Click [ Sony DSC] or [ Sony Handycam].
 - ② Click [Delete].

The “Device deletion confirmation” screen appears.
 - ③ Click [OK].

The device is deleted.

Try the USB driver installation again using the supplied CD-ROM (page 58).





4 Copying images **XP**

Copying images using “Image Transfer”

Windows XP is set so that the OS Auto Playback Wizard activates. Follow the procedure below to cancel the setting.

* This procedure does not need to be performed for subsequent image downloads.

- 1 Connect the camera and your computer with a USB cable (page 68).**
- 2 Click [Start], then click [My Computer].**
- 3 Right-click [Sony MemoryStick], then click [Properties].**

4 Cancel the setting.

- ① Set [Content type] to [Pictures].
- ② Check [Select an action to perform] under [Actions], select [Take no action], then click [Apply].
- ③ Set [Content type] to [Video files] and [Mixed content], and repeat step **2**.
- ④ Click [OK].
The [Properties] screen closes.

5 Disconnect and then reconnect the USB cable (page 69).

“Image Transfer” starts up automatically and the images are automatically copied to the computer.

Copying images using the Windows XP copy wizard

- 1 Click [Copy pictures to a folder on my computer using Microsoft Scanner and Camera Wizard], then click [OK].**

The “Scanner and Camera Wizard” screen appears.

- When performing the steps on page 68, the copy wizard appears on the desktop of your computer.

- 2 Click [Next].**

The images stored on the “Memory Stick” are displayed.

- 3 Click the checkbox of images that you do not want to copy to your computer and remove the checkmark, then click [Next].**

The “Picture Name and Destination” screen appears.

- 4 Specify the image group names to be copied and the copy destination, then click [Next].**

Image copying starts. When the copying is completed, the “Other Options” screen appears.

- The images are copied into the “My Documents” folder as an example.

- 5 Select [Nothing. I’m finished working with these pictures], then click [Next].**

The “Completing the Scanner and Camera Wizard” screen appears.

- 6 Click [Finish].**

The wizard closes.

- To continue copying other images, disconnect the USB cable and reconnect it. Then, perform the procedure from step **1** again.



Image file storage destinations and image file names

Image files recorded with your camera are grouped as folders in the “Memory Stick” by recording mode.

Example: For Windows Me users

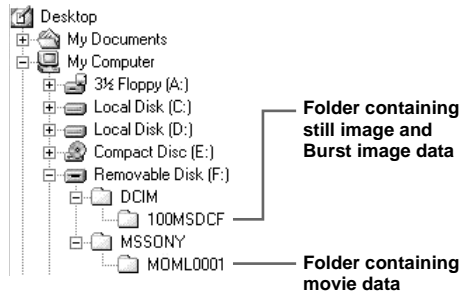

Notes

The meanings of the file names in the following table are as follows:

□□□□ stands for any number within the range from 0001 to 9999.

Folder	File name	File meaning
100MSDCF	DSC0□□□□.JPG	Still image file recorded normally Still image file recorded in Burst mode (page 38)
MOML0001	MOV0□□□□.MPG	Movie file recorded normally (page 48)

5 Viewing the images on your computer

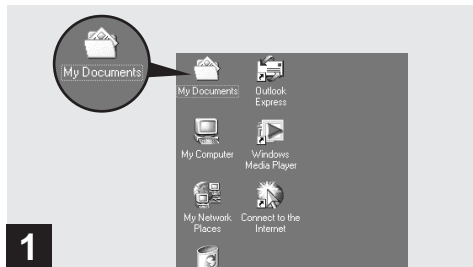

➔ **Double-click [My Documents] on the desktop.**

The “My Documents” folder contents are displayed.

- This section describes the procedure for copying images to the “My Documents” folder on pages 70 and 72.
- When using Windows XP, double-click [Start] → [My Documents] in that order.
- You can use the “PIXELA ImageMixer for Sony” software to view images on your computer. For details, see the software’s help files.

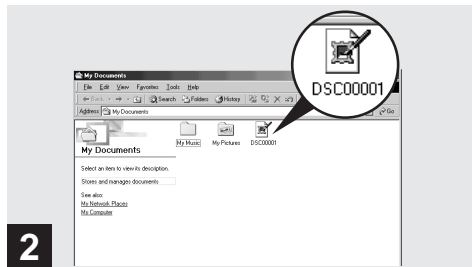

➔ **Double-click the desired image file.**

The image is displayed.







For Macintosh users

Follow the steps below, according to your OS.

OS	Steps
Mac OS 8.5.1/8.6/9.0	Steps 1 to 5
Mac OS 9.1/9.2/Mac OS X (v10.0/v10.1)	Steps 2 to 5

1 Installing the USB driver and ImageMixer

* For Mac OS 8.5.1, 8.6, or 9.0 users only

- 1 Turn on your computer, and set the supplied CD-ROM into the CD-ROM drive.
The “PIXELA ImageMixer” screen appears.
- 2 Double-click  (Setup Menu).
- 3 Click  (USB Driver).
The “USB Driver” screen appears.
- 4 Double-click the icon of the hard disk containing the OS to open the screen.
- 5 Drag and drop the following two files from the screen opened in step 3 into the System Folder icon in the screen opened in step 4.
 - Sony USB Driver
 - Sony USB Shim

- 6 When the message for confirmation is shown, click “OK.”
- 7 Select the desired language.
- 8 Follow the instructions on each succeeding screen.
- 9 Restart your computer and remove the CD-ROM from the CD-ROM drive.

2 Preparing your camera

For details, see page 67.

3 Connecting your camera to your computer

For details, see page 68.

Removing the USB cable from your computer or the “Memory Stick” from your camera during a USB connection

Drag and drop the drive icon of the “Memory Stick” to the “Trash” icon, then remove the USB cable or “Memory Stick.”

* If you are using Mac OS X, remove the USB cable, etc., after you have turned your computer off.

④ Copying images

- 1 Double-click the newly recognized icon on the desktop.
The contents of the “Memory Stick” inserted in your camera appear.
- 2 Double-click “DCIM.”
- 3 Double-click “100MSDCF.”
- 4 Drag and drop the image files to the hard disk icon.
The image files are copied to your hard disk.

⑤ Viewing the images on your computer

- 1 Double-click the hard disk icon.
 - 2 Double-click the desired image file in the folder containing the copied files.
The image file opens.
- You can use the “PIXELA ImageMixer for Sony” software to copy images to your computer and to view images on your computer. For details, see the software’s help files.



Troubleshooting

If you experience trouble with your camera, try the following solutions.

- 1 First check the items on the tables below. **If code displays “C:□□:□□” appear on the LCD screen, the self-diagnostics display function is working (page 86).**
- 2 Should your camera still not work properly, press the RESET button on the bottom of the camera using a fine-tipped object, then turn on the power again. (All the settings including date and time are cleared.)

- 3 Should your camera still not work properly, consult your Sony dealer or local authorized Sony service facility.

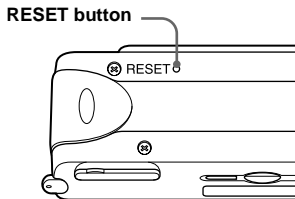

Batteries and power





Symptom	Cause	Solution
The battery remaining indicator is incorrect, or sufficient battery remaining indicator is displayed but the power runs out soon.	<ul style="list-style-type: none">• You have used the camera for a long time in an extremely hot or an extremely cold location.• The batteries are discharged.• The battery contacts or the terminals on the battery/“Memory Stick” cover are dirty.• The Nickel Metal Hydride batteries are exhibiting the “memory effect” (page 14).• The batteries are dead (page 93).	<p>—</p> <ul style="list-style-type: none">→ Install charged batteries (page 16).→ Wipe any dirt off from them with a dry cloth (page 16).→ To restore the batteries to their original condition, use them until they are fully drained before recharging them.→ Replace the batteries with a new one.

Symptom	Cause	Solution
The battery life is short.	<ul style="list-style-type: none"> You are shooting/viewing images in an extremely cold location. The batteries are not charged enough. The batteries are dead (page 93). 	<p>—</p> <p>→ Charge the batteries (page 16). → Replace the batteries with a new one.</p>
You cannot turn on the camera.	<ul style="list-style-type: none"> The batteries are not installed correctly. 	→ Install the batteries correctly (page 16).
The power turns off suddenly.	<ul style="list-style-type: none"> If you do not operate the camera for about three minutes when using batteries, the camera turns off automatically to prevent wearing down the battery (page 19). The batteries are discharged. 	<p>→ Turn on the camera again (page 19).</p> <p>→ Replace them with charged batteries (page 16).</p>

Shooting images

Symptom	Cause	Solution
The subject does not appear on the LCD screen.	<ul style="list-style-type: none"> The mode switch is set to PLAY. 	→ Set the mode switch to STILL or MOVIE (pages 26 and 48).
The image is out of focus.	<ul style="list-style-type: none"> The subject is too close. The vivid nature mode is selected for the Scene Selection function. The Focus preset function is selected. 	<p>→ Make sure to position the lens farther away from the subject than the shortest shooting distance (10 cm) when shooting (page 36). → Set it to other modes (page 34).</p> <p>→ Set it to [AUTO] (page 37).</p>
The image is too dark.	<ul style="list-style-type: none"> The LCD screen is too dark. 	→ Set [LCD LIGHT] to [ON] (page 28).
The image is too bright.	<ul style="list-style-type: none"> The LCD screen is too bright. 	→ Set [LCD LIGHT] to [OFF] (page 28).
The image is monochrome (black and white).	<ul style="list-style-type: none"> [P. EFFECT] is set to [B&W] mode. 	→ Cancel [B&W] mode (page 40).
Vertical streaks appear when you are shooting a very bright subject.	<ul style="list-style-type: none"> The smear phenomenon is occurring. 	→ This is not a malfunction.



Symptom	Cause	Solution
Your camera cannot record images.	<ul style="list-style-type: none"> • No “Memory Stick” is inserted. • The capacity of the “Memory Stick” is insufficient. • The write-protect switch on the “Memory Stick” is set to the LOCK position. • You cannot shoot while the flash is charging. • The mode switch is not set to STILL while shooting a still image. • The mode switch is not set to MOVIE when shooting a movie. 	<ul style="list-style-type: none"> → Insert a “Memory Stick” (page 22). → Delete the images saved in the “Memory Stick,” or format it. → Change the “Memory Stick.” → Set it to the recording position (page 92). → Wait until charging is complete before you begin shooting with the camera. → Set it to STILL (page 26). → Set it to MOVIE (page 48).
The flash does not work.	<ul style="list-style-type: none"> • The mode switch is set to PLAY or MOVIE. • The flash is set to  (no flash). • The vivid nature mode is selected for the Scene Selection function, or Burst mode in the image size. 	<ul style="list-style-type: none"> → Set it to STILL. → Set the flash to auto (no indicator),  (Red-eye reduction) or  (Forced flash) (page 32). → Set the flash to  (Forced flash) (page 32).
The eyes of the subject come out red.	—	→ Set the flash mode to  (Red-eye reduction) (page 32).
The date and time are recorded incorrectly.	<ul style="list-style-type: none"> • The date and time are not set correctly. 	→ Set the correct date and time (page 20).

Viewing images

Symptom	Cause	Solution
Your camera cannot play back images.	<ul style="list-style-type: none">The mode switch is not set to PLAY.Your camera may not play back image files copied from the hard disk of your computer if the file name or file size has been changed or the image has been modified.	→ Set it to PLAY (page 43). —
The image cannot be played back on a computer.	—	→ See page 83.
You cannot display a print mark.	<ul style="list-style-type: none">You cannot display print marks on moving images.	—

Deleting images

Symptom	Cause	Solution
Your camera cannot delete an image.	<ul style="list-style-type: none">The write-protect switch on the “Memory Stick” is set to the LOCK position.	→ Set it to the recording position (page 92).
Even though you attempted to delete all of the files, the “Memory Stick” is still not empty.	<ul style="list-style-type: none">The “Memory Stick” contains a file with a file name or storage destination that was changed through the computer.Even the “DELETE ALL” function will not erase files that were write-protected by another device.	→ Format the “Memory Stick” (page 54). → Format the “Memory Stick.”
You have deleted an image by mistake.	<ul style="list-style-type: none">Once you have deleted a file, you cannot restore it.	→ The write-protect switch on the “Memory Stick” will prevent you from deleting images by mistake (page 92).

Computers

Symptom	Cause	Solution
You do not know if the OS of your computer is compatible.	—	→ Check “Recommended computer environment” (page 56).
You cannot install the USB driver.	— <ul style="list-style-type: none"> You are attempting to install the USB driver on a machine that is not running a supported OS. 	→ In Windows 2000, log on as Administrators (authorized Administrators) (page 59). → —
Your computer does not recognize your camera.	<ul style="list-style-type: none"> You are not using the supplied USB cable. The USB cable is not connected firmly. [USB] is set to [PTP] in the . The USB connectors on your computer are connected to other equipment besides the keyboard, the mouse, and your camera. The USB driver is not installed. The camera was connected to a computer with the USB cable before installing the USB driver, so the device was not recognized by the computer. No “Memory Stick” is inserted. 	→ Use the supplied USB cable (page 68). → Disconnect the USB cable, and connect it again firmly. Make sure that “USB MODE” is displayed on the LCD screen (pages 68 and 89). → Set it to [NORMAL] (page 89). → Disconnect the USB cables except for the ones connected to the keyboard, the mouse, and your camera. → Install the USB driver (page 58). → Delete the device which is not recognized, then install the USB driver (pages 58 and 71). → Insert a “Memory Stick.”
You cannot copy images.	<ul style="list-style-type: none"> The camera is not correctly connected to your computer. You are not using the correct copy procedure for your OS. —	→ Connect the camera and your computer correctly using the USB cable (page 68). → Follow the designated copy procedure for your OS (page 56). → If you are using the “PIXELA ImageMixer for Sony” application software, click on HELP.

Symptom	Cause	Solution
You cannot turn on the camera during USB connection.	<ul style="list-style-type: none"> The camera and your computer are connected through a hub. 	<ul style="list-style-type: none"> → Connect the camera directly to your computer, or use a hub with output of 500 mA.
The image cannot be played back on a computer.	—	<ul style="list-style-type: none"> → If you are using the “PIXELA ImageMixer for Sony” application software, click on HELP. → Consult the computer or software manufacturer.
The image is interrupted by noise when you view a movie on a computer.	<ul style="list-style-type: none"> You are playing back the file directly from the “Memory Stick.” 	<ul style="list-style-type: none"> → Copy the file to the hard disk of your computer and then play back the file from the hard disk (pages 70, 72 and 77).
You cannot print an image.	—	<ul style="list-style-type: none"> → Check the printer settings. → Click on the HELP files for the “PIXELA ImageMixer for Sony” application software.

“Memory Stick”

Symptom	Cause	Solution
You cannot insert a “Memory Stick.”	<ul style="list-style-type: none"> You are inserting it backwards. 	<ul style="list-style-type: none"> → Insert it from the right side (page 22).
You cannot record on a “Memory Stick.”	<ul style="list-style-type: none"> The write-protect switch on the “Memory Stick” is set to the LOCK position. The “Memory Stick” is full. 	<ul style="list-style-type: none"> → Set it to the recording position (page 92). → Delete unnecessary images (page 52).
You cannot format a “Memory Stick.”	<ul style="list-style-type: none"> The write-protect switch on the “Memory Stick” is set to the LOCK position. 	<ul style="list-style-type: none"> → Set it to the recording position (page 92).
You have formatted a “Memory Stick” by mistake.	<ul style="list-style-type: none"> All the images on the “Memory Stick” are deleted by formatting and cannot be restored. 	—

Other

Symptom	Cause	Solution
Your camera does not work.	<ul style="list-style-type: none">• The battery level is low. (The  indicator appears.)• The USB cable is connected.• The built-in microcomputer is not working properly.	<ul style="list-style-type: none">→ Charge the batteries (page 12).→ Disconnect the USB cable, or operate on your computer.→ Turn the power off and then on after one minute, and check that the camera works properly.
The power is on, but the camera does not work.	<ul style="list-style-type: none">• The built-in microcomputer is not working properly.	<ul style="list-style-type: none">→ Remove the batteries, then install them again after about one minute and turn on the camera. If the functions still do not work, press the RESET button located on the bottom of the camera using a fine-tipped object, then turn the power on again (page 78). (If you press the RESET button, all settings including the date and time are cleared.)
You cannot identify an indicator on the LCD screen.	—	<ul style="list-style-type: none">→ Check the indicator (page 96).
The lens gets fogged.	<ul style="list-style-type: none">• Moisture condensation has occurred.	<ul style="list-style-type: none">→ Turn off the camera and wait for about an hour at the room temperature for the moisture to evaporate before use (page 91).

Warnings and messages

The following messages appear on the LCD screen.

Message	Meaning/Corrective Action
NO MEMORY STICK	<ul style="list-style-type: none">• Insert a “Memory Stick” (page 22).
SYSTEM ERROR	<ul style="list-style-type: none">• Turn the power off and on again (page 19).
MEMORY STICK ERROR	<ul style="list-style-type: none">• The inserted “Memory Stick” cannot be used in your camera (page 92).• The “Memory Stick” is damaged, or the terminal section of the “Memory Stick” is dirty.• Insert the “Memory Stick” correctly (page 22).
FORMAT ERROR	<ul style="list-style-type: none">• The “Memory Stick” format failed. Format the “Memory Stick” again (page 54).
MEMORY STICK LOCKED	<ul style="list-style-type: none">• The write-protect switch on the “Memory Stick” is set to the LOCK position. Set it to the recording position (page 92).
NO MEMORY SPACE	<ul style="list-style-type: none">• The capacity of the “Memory Stick” is insufficient. You cannot record images. Delete unnecessary images (page 52).
NO FILE	<ul style="list-style-type: none">• No images have been recorded on the “Memory Stick.”
FILE ERROR	<ul style="list-style-type: none">• An error occurred while playing back the image.
FOLDER ERROR	<ul style="list-style-type: none">• A folder with the same name already exists on the “Memory Stick.”
INVALID OPERATION	<ul style="list-style-type: none">• You are playing back a file that was created on equipment other than this camera.• You are attempting to assign the print mark to a file that contains a movie or that was created by another device.
	<ul style="list-style-type: none">• The battery level is low or zero. Charge the batteries (page 12). Depending on the conditions of use or the type of batteries, the indicator may flash even though there are still 5 to 10 minutes of remaining battery time left.
LENS COVER CLOSED	<ul style="list-style-type: none">• The lens cover is closed when the mode switch is set to STILL or MOVIE.
SHOOTING ERROR	<ul style="list-style-type: none">• Change the image size and try the shooting again.

Self-diagnostics display

– If a code starting with an alphabet letter appears

Your camera has a self-diagnostics display. This function displays the camera condition on the LCD screen with a combination of a letter and four numerical digits. If this occurs, check the following code chart and attempt the corresponding corrective actions. The last two digits (indicated by □□) will differ depending on the state of the camera.

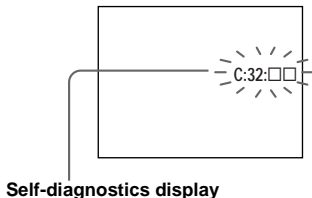

Code	Cause	Corrective action
C:32: □□	There is trouble with your camera's hardware, or with the zoom function.	<ul style="list-style-type: none">• Turn the power off and on again (page 19).
C:13: □□	The camera cannot read or write data in the "Memory Stick."	<ul style="list-style-type: none">• Re-insert the "Memory Stick" several times.
	An unformatted "Memory Stick" is inserted.	<ul style="list-style-type: none">• Format the "Memory Stick" (page 54).
	The inserted "Memory Stick" cannot be used with your camera, or the data is damaged.	<ul style="list-style-type: none">• Insert a new "Memory Stick" (page 22).
E:61: □□ E:91: □□	A camera malfunction that you cannot reverse has occurred.	<ul style="list-style-type: none">• Press the RESET button (page 78) located on the bottom of the camera, then turn the power on again.

If you are unable to solve the problem even after trying the corrective actions a few times, repairs may be necessary. Contact your Sony dealer or local authorized

Sony service facility and inform them of the 5-digit code. (Example: E61:10)

Menu items

Menu items that can be modified differ depending on the position of the mode switch.

The LCD screen shows only the items you can operate at the moment. Factory settings are indicated with ■.

When the mode switch is set to STILL (when [📷] is selected)

Item	Setting	Description
SIZE-BURST	■1280×960 / 640×480 / BURST	Selects the image size when shooting still images (pages 23 and 38).
FOCUS	■AUTO / 🌸 0.2 m / 👤 0.5 m / 👤 1.0 m / 🏞️ ∞	Selects the auto focus method or sets the focus preset (page 36).
SELFTIMER	ON / ■OFF	Sets the self-timer (page 29).
P.EFFECT	■OFF / NEG. ART / SEPIA / B&W / SOLARIZE	Sets the image special effects (page 40).

When the mode switch is set to MOVIE (when [🎥] is selected)

Item	Setting	Description
FOCUS	■AUTO / 🌸 0.2 m / 👤 0.5 m / 👤 1.0 m / 🏞️ ∞	Selects the auto focus method or sets the focus preset (page 36).
SELFTIMER	ON / ■OFF	Sets the self-timer (page 29).
P.EFFECT	■OFF / NEG. ART / SEPIA / B&W / SOLARIZE	Sets the image special effects (page 40).

When the mode switch is set to PLAY (when [▶] is selected)

Item	Setting	Description
DELETE	OK CANCEL	<ul style="list-style-type: none">- Deletes the displayed image (page 52).- Cancels deleting of the image.
DELETE ALL	OK CANCEL	<ul style="list-style-type: none">- Deletes all images (page 52).- Cancels deleting of the image.
INDEX / SINGLE	—	Switches between four-image display and single image display.
PRINT	ON / OFF	Marks/unmarks the print mark on still images you want to print (page 46).

* The following menus are available no matter what position the mode switch is in.

When [□] is selected

Item	Setting	Description
LCD LIGHT	■ON / OFF	Selects the brightness of the LCD light. Selecting [ON] makes the screen bright and easy to see when using the camera in dark locations, but also uses up the battery charge faster (page 28).
DISPLAY	ON ■OFF	<ul style="list-style-type: none">- Displays all indicators.- Displays only warning messages.

When [] is selected

Item	Setting	Description
CLOCK SET	DATE NOTATION	– Set the date notation (page 20). ■[Y/M/D] / [M/D/Y] / [D/M/Y]
	DATE&TIME SET	– Sets the date and time (page 20).
BEEP	■ON	– Turns on the beep/shutter sound when you press the control button/shutter button.
	SHUTTER	– Turns on the shutter sound. (The shutter sound is heard when you press the shutter button.)
	OFF	– Turns off the beep/shutter sound.
USB	■NORMAL / PTP	Switches the USB mode (page 57).
LANG / 言語	日本語 / JPN	– Displays the menu items, warnings and messages in Japanese.
	■ENGLISH	– Displays the menu items, warnings and messages in English.

When [] is selected

Item	Setting	Description
FORMAT	OK / CANCEL	Formats the “Memory Stick.” Note that formatting erases all the information recorded on the “Memory Stick” (page 54).

Precautions

On cleaning

Cleaning the LCD screen

Wipe the screen surface with an LCD cleaning kit (not supplied) to remove fingerprints, dust, etc.

Cleaning the lens

Wipe the lens with a soft cloth to remove fingerprints, dust, etc.

Cleaning the camera surface

Clean the camera surface with a soft cloth slightly moistened with water, then wipe the surface dry. Do not use any type of solvent such as thinner, alcohol or benzine as this may damage the finish or the casing.

After using your camera at the seashore or other dusty locations

Clean your camera carefully. Otherwise, the salty air may corrode the metal fittings or dust may enter the inside of your camera, causing a malfunction.

Note on operating temperature

Your camera is designed for use between the temperatures of 0°C and 40°C (32°F and 104°F). Shooting in extremely cold or hot places that exceed this range is not recommended.

On moisture condensation

If the camera is brought directly from a cold to a warm location, or is placed in a very damp room, moisture may condense inside or outside the camera. Should this occur, the camera will not operate properly.

Moisture condensation occurs easily when:

- The camera is brought from a cold location such as a ski slope into a warmly heated room.
- The camera is taken from an air-conditioned room or car interior to the hot outdoors, etc.

How to prevent moisture condensation

When bringing the camera from a cold place to a warm place, seal the camera in a plastic bag and allow it to adapt to conditions at the new location over a period of time (about an hour).

If moisture condensation occurs

Turn off the camera and wait about an hour for the moisture to evaporate. Note that if you attempt to shoot with moisture remaining inside the lens, you will be unable to record clear images.

On internal rechargeable button battery

This camera has an internal rechargeable button battery for maintaining the date and time and other settings regardless of whether the power is on or off.

This rechargeable button battery is continually charged as long as you are using the camera. However, if you use the camera for only short periods it discharges gradually, and if you do not use the camera at all for about one month it becomes completely discharged. In this case, be sure to charge this rechargeable button battery before using the camera.

However, even if this rechargeable button battery is not charged, you can still use the camera as long as you do not record the date and time.

Charging method of rechargeable button battery

Install charged size AAA Nickel Metal Hydride batteries, and leave the camera for 24 hours or more with the power off.

On "Memory Stick"

"Memory Stick" is a new compact, portable and versatile IC recording medium with a data capacity that exceeds the capacity of a floppy disk.

There are two types of "Memory Stick": an ordinary "Memory Stick" and a "MagicGate Memory Stick" that are equipped with the MagicGate copyright protection technology. You can use both types of "Memory Stick" with your camera. However, because your camera does not support the MagicGate standards, data recorded with your camera is not subject to MagicGate* copyright protection.

* MagicGate is copyright protection technology that uses encryption technology.

- Do not remove the "Memory Stick" while reading or writing data.
- When you carry or store the "Memory Stick," put it in the case supplied with it.

- You cannot record or delete images when the write-protect switch is set to LOCK. The position or the shape of the write-protect switch may differ depending on the "Memory Stick" you use.

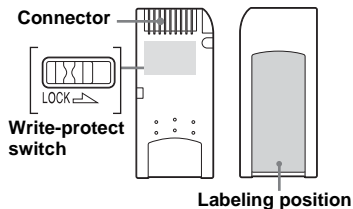

- Data may be damaged in a location subject to the effects of static electricity or noise.
- Do not attach any other material than the supplied label on the labeling position.
- Do not touch the connector of a "Memory Stick" with your hand or a metal object.
- Do not strike, bend or drop a "Memory Stick."
- Do not disassemble or modify a "Memory Stick."
- Do not expose the "Memory Stick" to water.

On Nickel Metal Hydride batteries

Effective use of the battery

- We recommend that you use batteries until they are completely drained before charging them.
- Battery performance decreases in low-temperature surroundings, and the battery life is shortened under such circumstances. To use the battery longer, we recommend you keep the battery in its case in a pocket close to your body to warm it, and insert it in your camera just before you start shooting.
- If you use the LCD screen with [LCD LIGHT] to [ON], the battery power will be used up faster.
- We recommend having spare batteries handy for two or three times the expected shooting time, and try test shooting before actually using the camera.
- Do not expose the battery to water. The battery is not water-resistant.

Battery life

- The battery life is limited. Battery capacity decreases little by little as you use it more and more, and as time passes. When the battery operating time seems to have been considerably shortened, a probable cause is that the batteries have reached the end of its life.
- The battery life varies depending on storage, operating conditions, and environment, and is different for each battery.

Specifications

System

Image device	6.65 mm (1/2.7 type) color CCD Primary color filter
Total pixels number of camera	Approx. 1 340 000 pixels
Effective pixels number of camera	Approx. 1 260 000 pixels
Lens	Single focal lens f = 5.0 mm (7/32 inches) (35 mm camera conversion: 33 mm (1 5/16 inches)) F2.8
Exposure control	Automatic, Scene selection (three modes)
Data formats	Still images: DCF compliant (Exif Ver. 2.2 JPEG compliant), DPOF compatible Movies: MPEG1 compliant (without audio)
Recording media	“Memory Stick”
Flash	Recommended distance: 0.5 m to 1.8 m (1.6 to 6.0 ft)

Connector

USB jack mini-B

LCD screen

LCD panel used	2.5 cm (1.0 type) TFT drive
Total number of dots	64 460 (293×220) dots

Power, general

Used batteries	AAA Nickel Metal Hydride batteries (2) 2.4 V 5 V (from USB cable)
Power consumption (when shooting)	1.25 W
Operating temperature range	0°C to +40°C (32°F to +104°F)
Storage temperature range	-20°C to +60°C (-4°F to +140°F)
Dimensions	85 × 29 × 40 mm (3 3/8 × 1 3/16 × 1 5/8 inches) (W/H/D, protruding portions not included)
Mass	118 g (4.2 oz) (AAA Nickel Metal Hydride batteries, “Memory Stick,” and neck strap included)

BC-CS1 Ni-MH battery charger

Power requirements

AC 100 to 240V 50/60Hz
2.2 W

Output voltage

Size AA: DC 1.8V, 165 mA × 2
Size AAA: DC 1.8V, 70 mA × 2

Dimensions 70 × 29 × 74 mm (2 7/8 × 1 3/16 × 3 inches)
(W/H/D)

Mass Approx. 70g (2.5 oz.)

Operating temperature range

0°C to 40°C (32°F to 104°F)

Accessories

- Size AAA Ni-MH batteries (2)
- Ni-MH battery charger (1)
- Power cord (mains lead) (1)
- USB cable (1)
- Neck strap (1)
- “Memory Stick” (8MB) (1)
- CD-ROM (SPVD-008) (1)
- Operating instructions (1)

Design and specifications are subject to change without notice.

When shooting still images

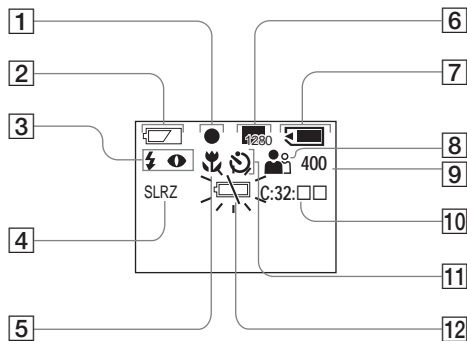

- 1 AE/AF indicator (27)
- 2 Battery remaining indicator (15)
- 3 Flash mode indicator (32)
Red-eye reduction indicator (32)
- 4 Picture effect indicator (40)
- 5 Focus preset indicator (36)
- 6 Image size indicator (23, 38)
- 7 Remaining "Memory Stick" capacity indicator
- 8 Scene selection indicator (34)
- 9 Remaining number of recordable images indicator
- 10 Self-diagnostics function indicator (86)
- 11 Self-timer indicator (30)
- 12 Low battery warning indicator (15)

When shooting movies

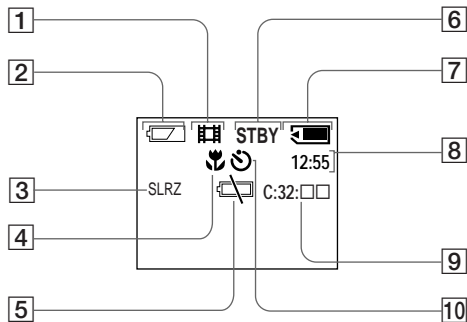

- 1 Recording mode indicator (48)
- 2 Battery remaining indicator (15)
- 3 Picture effect indicator (40)
- 4 Focus preset indicator (36)
- 5 Low battery warning indicator (15)
- 6 Status indicator (48)
- 7 Remaining "Memory Stick" capacity indicator
- 8 Recording time [maximum recordable time] indicator (50)
- 9 Self-diagnostics function indicator (86)
- 10 Self-timer indicator (30)

When playing back still images

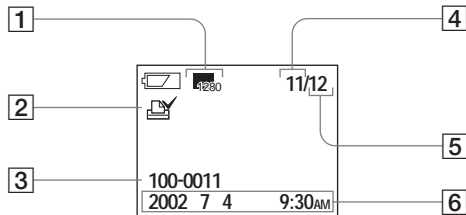

- 1 Image size indicator (25)
- 2 Print mark indicator (46)
- 3 File name (42)
- 4 Image number
- 5 Number of images recorded in “Memory Stick”
- 6 Recording date of the playback image

When playing back moving images

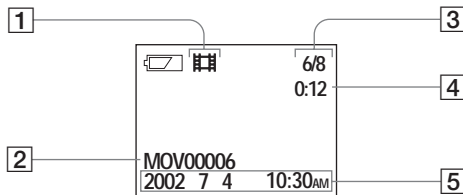

- 1 Recording mode indicator (48)
- 2 File name (50)
- 3 Image number/Number of images recorded in “Memory Stick”
- 4 Counter
- 5 Recording date of the playback image

Index

A

Access lamp	23
AE/AF lock	26
Auto Focus	28
Auto power-off function	19

B

Battery	
charging time	15
preparing batteries	12
remaining indicator	15
Battery life	17
BEEP	89
Burst	38

C

Charging	
charging the batteries	12
charging time	15
Cleaning	90
Clock set	20

Computer

copying images	56, 70
Image Transfer	61
ImageMixer	64
USB cable	68
USB driver	58
Control button	11
Copying images	56, 70

D

Deleting images	52
DPOF	46

E

EXEC	24
Exif	94



F	
File	
file names	74
image file storage destinations	74
Flash	
Red-eye reduction	32, 33, 34
selecting a flash mode	32
Focusing	
focus preset	36
shooting (using auto adjustment mode)	26
Formatting a “Memory Stick”	54
I	
Image	
copying images to your computer	56, 70
file names	74
image file storage destinations	74
image size	23, 25, 87
Index screen	44
Installation	
Image Transfer	61
ImageMixer	64
USB driver	58
J	
JPEG	26
L	
LCD screen	
DISPLAY	29, 96
LCD LIGHT	28
M	
“Memory Stick”	
formatting a “Memory Stick”	54
inserting/removing a “Memory Stick”	22
number of images that can be saved/shooting time ...	25, 50
MENU	23
Menu settings	87
Mode switch	10
Moisture condensation	91
Movie	
shooting images	48
shooting time	18
viewing images on an LCD screen	50
viewing images on your computer	75
MPEG	48, 74

P

Picture effect	40
POWER	19
Power	
batteries	12
inserting the batteries	16
ON/OFF	19
Precautions	90
Print mark	46

R

Red-eye reduction	32, 33, 34
RESET button	78, 86

S

SCENE	35
Scene Selection (SCENE)	34
Self-diagnostics display	86
Self-timer	29
Setting	
date and time	20
image size	23
menu items	87
Setting the date and time	20

Shooting mode

auto adjustment mode	26
Burst	38
movie	48
Single image screen	43
Still image playback	
Viewing the images on your computer	75
Still image shooting	
auto focus	26
image size	23
number of images that can be saved	25
picture effect	40
Scene Selection	34
using auto adjustment mode	26
using the flash	32
using the self-timer	29
Still image viewing	
index screen	44
single image screen	43
viewing images on an LCD screen	42
viewing images on your computer	75
SXGA	17



U

USB	56, 69
USB Bus Powered	57
Using your camera abroad	18

V

VGA	17
Viewing images on an LCD screen	43, 50
Viewing images on your computer	75

W

Warnings and notice messages	85
------------------------------------	----

307655912



Printed on recycled paper using VOC
(Volatile Organic Compound)-free
vegetable oil based ink.

The Sony customer support web page URL is as follows:
<http://www.sony.net/>
Sony Corporation Printed in Japan