



BX500 - Blender Only

BX525 - Blender & Coffee Grinder

BX550 - Blender, Coffee Grinder & Cheese Grater



First Use safety Recommendation

Please read through this booklet for safe and efficient use of the appliance.
We urge you read and follow all instructions, even if you are familiar with a similar appliance.

Keep this guide handy for future reference.

English Page 02
Farsi Page 12
Arabic Page 18

BX500 - BX525 - BX550

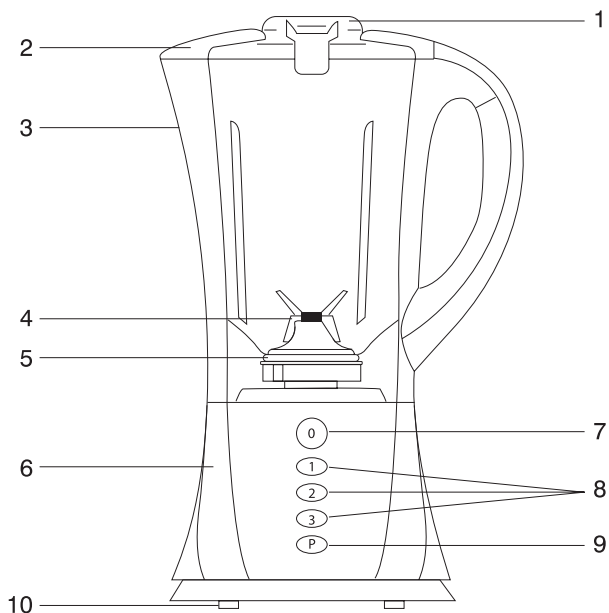

BX525 & BX550

BX550 only

BX525 & BX550

BX550 only

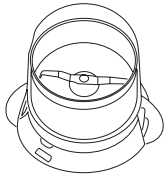

11

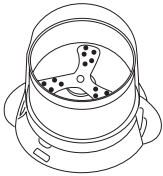

12



13

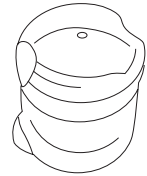

14

Features

1	Filler Cap	8	Speed Buttons
2	Lid	9	Pulse Button
3	Jar	10	Feet
4	Blade Assembly	11	Coffee Grinder
5	Sealing Ring	12	Cheese Grater
6	Motor Base	13	Grinder Cover
7	Off Button	14	Grater Cover

Intended use

Your Black & Decker Blender has been designed for processing ingredients as listed in this manual.

This appliance is intended for indoor consumer use only.

Safety Instructions

- Warning! When using mains-powered appliances, basic safety precautions, including the following, should always be followed to reduce the risk of fire, electric shock, personal injury and material damage.
- Read all of this manual carefully before using the appliance.
- The intended use is described in this manual. The use of any accessory or attachment or the performance of any operation with this appliance other than those recommended in this instruction manual may present a risk of personal injury.
- Retain this manual for future reference.
- Always route the cord carefully to avoid a tripping hazard.
- Never operate an appliance directly below the socket-outlet it is connected to.

Using your appliance

- Make sure that the appliance is switched off before connecting to or disconnecting from the power supply.
- Always take care when using the appliance.
- Do not use the appliance outdoors.
- Never pull the power supply cord to disconnect the plug from the socket. Keep the power supply cord away from heat, oil and sharp edges.
- Disconnect the appliance from the power supply when not in use, before fitting or removing parts, maintenance and before cleaning.
- Surfaces may be hot during use and during the cool down period
- Do not operate or place any part of this appliance on or near any hot surface, such as a gas or electric burner or in a heated oven.
- When using an extension cord with your appliance, make sure the extension cord is correctly wired & rated for its use.

Safety of others

- Do not allow children or any person unfamiliar with these instructions to use the appliance.
- Do not allow children or animals to come near the work area or to touch the appliance or power supply cord. Close supervision is necessary when the appliance is used near children.
- Never leave an appliance unattended when in use
- Do not allow the cord set to hang over bench tops

After use

- Switch off and remove the plug from the socket before leaving the appliance unattended and before changing, cleaning or inspecting any parts of the appliance.
- When not in use, the appliance should be stored in a dry place. Children should not have access to stored appliances.

Inspection and repairs

- Before use, check the appliance for damaged or defective parts. Check for breakage of parts, damage to switches and any other conditions that may affect its operation.
- Do not use the appliance if any part is damaged or defective.
- Have any damaged or defective parts repaired or replaced by an authorised repair agent.
- Before use, check the power supply cord for signs of damage, ageing and wear.
- Do not use the appliance if the power supply cord or mains plug is damaged or defective.
- If the power supply cord or mains plug is damaged or defective it must be repaired by the manufacturer or its service agent or a similarly qualified person in order to avoid a hazard. Do not cut the power supply cord and do not attempt to repair it yourself.
- Never attempt to remove or replace any parts other than those specified in this manual.
- Do not attempt to repair the appliance. Take it to your nearest Black & Decker-owned or authorised Service Centre for repair.

Double insulation



This appliance is double insulated; therefore no earth wire is required. Always check that the power supply corresponds to the voltage on the rating plate.

Additional safety instructions for Blenders

- Do not immerse the appliance, cord set or plug in liquids
- Always leave sufficient space around the appliance for ventilation
- Keep loose clothing, hair, jewellery, etc. away from moving parts.
- Do not use the unit if you have wet hands or bare feet.
- Care is needed when handling cutting blades, especially when removing the blades from the bowl, emptying the bowl and during cleaning.
- Switch off the appliance before changing accessories or approaching parts which move in use.

Assembly

This appliance requires some assembly to complete the required task. Please refer to the relevant section for particular assembly details.

All parts should be cleaned before use. See “Cleaning” for details.

Use

As a Blender

Place the appliance on a clean, flat work surface.

Assemble the jar (3) by first placing the sealing ring (5) on the blade assembly (4). Position the blade assembly in the hole at the bottom of the jar (3) & rotate it in an anti-clockwise direction until it locks in place.

Place the assembled jar on the motor base (6), & rotate it in a clockwise direction until it locks in position.

Add the ingredients to the jar then fit the lid (2) and filler cap (1). The filler cap must be rotated clockwise until it locks in place.

Note: Do not exceed the maximum capacity of 1.5 litres.

Connect the appliance to a suitable electrical supply. Press the required speed button (8). The pulse button (9) can also be used to give greater control. When Blending is complete, either release the pulse button, or press the off button (7). Once the blades have come to a complete stop, rotate the jar (3) in an anticlockwise direction & lift it from the motor housing (6). Rotate the filler cap (1) anti-clockwise & lift it from the jar before removing the lid (2). Pour the ingredients into a suitable container.

Note: Ingredients can be added to the jug while the lid is off, or by inserting them through the hole left when the filler cap (1) is removed.

Note: The Blender will not operate unless the lid is correctly fitted.

Note: Do not operate the blender for longer than 2 minutes. After each the 2 minutes session the blender must be allowed to cool down for at least 10 minutes.

Note: The motor is equipped with an auto resetting thermostat. This may operate and stop blending if the appliance is overloaded. If this should happen, allow the Blender to cool down and remove some of the contents of the jar. The thermostat will take a few minutes to re-set.

As a Coffee Grinder (BX525 & BX550)

Remove the cover (13) from the coffee grinding attachment (11) by holding the cup & rotating the cover in an anti-clockwise direction. Add a maximum of 40g of coffee beans to the cup. Place the cover on the cup & rotate it clockwise until it locks in place. Position the assembly on the motor housing (6), rotating it clockwise until it locks into place. Press the required speed button (8) & allow the grinder to operate for a maximum of 30 seconds.

Note: After every operation of 30 seconds, the appliance must be allowed to cool down for at least 5 minutes.

Once grinding is completed, rotate the attachment (11) anti-clockwise to remove it from the motor base (6), then hold the cup & rotate the cover (13) anticlockwise to remove it so the contents can be poured into a suitable container.

As a Cheese Grater (BX550 Only)

Cheese should be cut into 15mm cubes before grinding. Remove the cover (14) from the cheese grating attachment (12) by holding the cup & rotating the cover in an anti-clockwise direction. Add the prepared cheese to the cup. Place the cover on the cup & rotate it clockwise until it locks in place. Position the assembly on the motor housing (6), rotating it clockwise until it locks into place. Press the required speed button (8) & allow the grater to operate for a maximum of 30 seconds.

Note: After every operation of 30 seconds, the appliance must be allowed to cool down for at least 5 minutes.

Once grating is completed, rotate the attachment (12) anti-clockwise to remove it from the motor base (6), then hold the cup & rotate the cover (14) anticlockwise to remove it so the contents can be poured into a suitable container

Food Guide

Blender

Ingredients	Runtime	Speed	Quantity
Liquids	25-35 sec	2 or 3	1.5 Litre
Semi liquids	15-20 sec	1	1Litre

Grinder

Ingredients	Runtime	Speed	Quantity
Pepper/Coffee beans	10-20 sec	1	40 gms
Pulses	20-30 sec	1	50 gms

Grater

Ingredients	Runtime	Speed	Quantity
Hard Cheese	10-20 sec	1	40 gms*
Soft Cheese	20-30 sec	1	50 gms*

*Cut into 15mm x 15mm

Do not operate the appliance continuously for more than 1 minute . After operating continuously for 1 minute , let it cool down for at least 3 minutes before operating it again.

Maintenance

Your Black & Decker tool has been designed to operate over a long period of time with a minimum of maintenance. Continuous satisfactory operation depends upon proper tool care and regular cleaning.

Warning! Before performing any maintenance or cleaning of the tool, disconnect the appliance from the power supply.

Ventilation slots should be cleaned occasionally with a clean, dry paint brush.

Cleaning

The motor housing should be cleaned with a clean damp cloth only.

The jar & grinding attachments can be washed in warm soapy water. Rinse with clean water and dry thoroughly with a dry soft cloth.

Note: Do not use abrasives or chemical cleaners on any part of this appliance.

Note: Take care when handling the blades, they are sharp & cannot be dismantled.

Protecting the environment



Separate collection. This product must not be disposed of with normal household waste. Should you find one day that your Black & Decker product needs replacement, or if it is of no further use to you, do not dispose of it with household waste. Make this product available for separate collection.



Separate collection of used products and packaging allows materials to be recycled and used again. Re-use of recycled materials helps prevent environmental pollution and reduces the demand for raw materials.

Local regulations may provide for separate collection of electrical products from the household, at municipal waste sites or by the retailer when you purchase a new product. Black & Decker provides a facility for the collection and recycling of Black & Decker products once they have reached the end of their working life. To take advantage of this service, please return your product to any authorised repair agent who will collect them on our behalf. You can check the location of your nearest authorised repair agent by contacting your local Black & Decker office at the address indicated in this manual. Alternatively, a list of authorised Black & Decker repair agents and full details of our after-sales service and contacts are available on the Internet at: www.2helpU.com

Names & Addresses for Black & Decker Service Concessionaries

Afghanistan: Ishan National Co., Opp. Ministry of Justice, Kabul. Tel.: +93-2-2101727. **Algeria:** SARL Outillage Corporation, 04 Route De Dely Brahim Cheraga, Alger. Tel.: +213-21-364363/508, Fax: +213-21-369667. **Bahrain:** Fawaz Al Zayani, P.O.Box 26563, Adliya, Manama. Tel.: +973-17-715252/712756, Fax: +973-17-713789. **Bangladesh:** Ultra Corporation, 8, Kushol Centre, Uttara, Dhaka 1230. Tel.: +880-2-8919272/9756 Ext.28, Fax: +880-2-9887167. **Egypt:** Anasia Egypt for Trading S. A. E., P.O.Box 2443, 110 Mostafa Relfaat Street, Sheraton Heliopolis 11361, Cairo. Tel.: +20-2-2684159, Fax: +20-2-2684169. **Ethiopia:** Tewfik Sherif & Co. Ltd., P.O.Box 5583, Debre Zeit Road, Addis Ababa. Tel.: +251-1-651700/601, Fax: +251-1-650570. **India:** Gryphon Impex Pvt. Ltd., D-6/4, Okhla Industrial Area, Phase-I, New Delhi-110020. Tel.: +91-11-26372602-4, Fax: +91-11-26372601. **Iran:** Tehran - Service Centre of Iran, No 510, South Karger Ave, Below Pasteur Sq, Tehran. Tel.: +98-21-6490608/0656/6407672. **Kish Island:** Cayhan Electric Co., No. 69, Paradise Shopping Centre, Kish Island. Tel.: +98-76444-22894. **Jordan:** Bashiti Hardware, P.O.Box 1564, TLA Ali, Amman. Tel.: +962-6-5350009/4770741, Fax: +962-6-5350012/4789783. **Kenya:** Zyllog Enterprises, IPS Building, Kuanda Street, P.O.Box 40877, Nairobi. Tel.: +254-2-338188/199, Fax: +254-2-330642. **Kuwait:** Al Omar Technical Co., P.O.Box 4062, 13041 Safat, Kuwait. Tel.: +965-4848595/0039, Fax: +965-4845652. **Lebanon:** Est. F.A. Kettaneh SA, P.O.Box 110242, Dora Highway, Kettaneh Building, Beirut. Tel.: +961-1-255860/6, Fax: +961-1-255891. **Libya:** El Ghoul Brothers, P.O.Box 348, Islamic Call Bldg., Office 201-202, Benghazi. Tel.: +218-61-9097681/4183, Fax: +218-61-9094123. **Madagascar:** Group Tana Confort S. A. R. L., B. P. 1770, Antananarivo. Tel.: +261-20-2264505, Fax: +261-20-2264244. **Malta:** John G. Cassar Ltd., 36 Victory Str, Qormi QRM 06, Malta. Tel.: +356-21-493251, Fax: +356-21-483231. **Mauritius:** Happy World Marketing Ltd., Block 2, Industrial Estate, Coromandel, P.O.Box 429, Port Louis. Tel.: +230-2076700, Fax: +230-2337330/7400. **Nepal:** Universal Trading Centre, P.O.Box 1947, Tripureswor, Kathmandu. Tel.: +977-1-262192/260587/785, Fax: 261154. **Nigeria:** Amin Bros. Eng. Co. Ltd., 30A (Plot 1291), Akin Adesola Street, Victoria Island, Lagos. Tel.: +234-1-3201778, Fax: +234-1-2613667. **Oman:** Oman Mktg. & Service Co., P.O.Box 2734, Ruwi, Muscat. Tel.: +968-560232, Fax: +968-560255. **Pakistan:** Karachi - Ammar Service & Spares, 60, Bank Arcade, Serai Road, Karachi. Tel.: +92-21-2426905, Fax: 2427214/5243. **Pakistan:** Lahore - Electronics Inn, 212-G Raja Centre, Main Market, Gulberg, Lahore. Tel.: +92-42-5756750. **Philippines:** Modern House International Enterprises, 213 Rizal Ave. Extension, between 2nd and 3rd Ave. Kalookan City. Tel.: +632 366-4487, Fax: +632 366-4489. **Qatar:** Al Muftah Trading & Cont., P.O.Box 875, Doha. Tel.: +974-4650880/4446868, Fax: +974-4441415. **Saudi Arabia:** Dammam - Ebrahim Fawaz Al Zayani, P.O.Box 76026, Al Raka, Dammam. Tel.: +966-3-8140914, Fax: +966-3-8140824. **Jeddah:** Anasia - P.O.Box 50959, Jeddah - 21477. Tel.: +966-2-6710014, Fax: +966-2-6725929. EAC (Al Yousuf) - P.O. Box 30377, Jeddah - 21477. Tel.: +966-2-6519912, Fax: +966-2-6511153. **Madina:** Garziz Trdg. for Bldg. Mat.&Decor., P.O.Box 3364, Madina. Tel.: +966-4-8261490/8227636, Fax: +966-4-8265741. **Riyadh:** Anasia, P.O.Box 18689, Riyadh - 11425. Tel.: +966-1-2693751, Fax: +966-1-4501178. **Yanbu:** Bin Afif, P.O.Box 530 Yanbu, Al Bahr. Tel.: +966-4-3222626/8867, Fax: +966-4-3222210. **Sri Lanka:** Delmege Gen. Equip. Pvt. Ltd., No. 428/1AT. B., Jaya Mawatha (Darley Road), Colombo-10. Tel.: +94-11-2665914, Fax: +94-11-2665915. **Sudan:** United Distribution Company, P.O.Box 325, Sayed Abdul Rehman Street, Khartoum. Tel.: +249-11-772612/777296, Fax: +249-11-770919. **Tanzania:** General Motors Investment, P. O Box 16541, 14 Vingunguti Nyerere Road, Dar Es Salaam. Tel.: +255-22-2862661/5022, Fax: +255-22-2862667/5412/3. **Tunisia:** Ste Tunisienne De Quincallerie Stq.Nvelle Z.I 2013, Ben Arous, Tunis, Tunisia, Tel. 00216 71386102, Fax: 00216 71380412, **Tunis:** Souissi Ace Home Centre, Zone Industrielle, Megrine (Saint Gobain), Z4-Tunis. Tel.: +216-1-428038, Fax: + 216-1- 429540/330. **UAE:** Abu Dhabi- Light House Electric., P.O.Box 120, Abu Dhabi. Tel.: +971-2-6726131, Fax: +971-2-6720667. **Dubai - Black & Decker (O) A.G.,** P.O.Box 5420, Dubai. Tel.: +971-4-7028234/233, Fax: +971-4-2822765. **Ideal Mach. & Eqipt. R. W/shop** P.O.Box 37116, Al Quoz, Dubai. Tel.: +971-4-3474160, Fax: +971-4-3474157. **Sharjah - McCoy Middle East LLC,** P.O.Box 20228, Sharjah. Tel.: +971-6-5336321, Fax: +971-6-5336320. **Uganda:** The Building Centre, Kitgum House, 52 Station Road, P.O.Box 7436, Kampala. Tel.: +256-41 -234567, Fax: +256-41 -236413. **Yemen:** Aden - Middle East Trad. Co. Ltd., Mulla Dakka, Aden. Tel.: +967-2-240950, Fax: +967-2-240952. **Sana'a:** Middle East Trad. Co. Ltd., P.O.Box 12363, Hayel Street, Sana'a. Tel.: +967-1-204201, Fax: +967-1-204204. **Taiz:** Middle East Trad. Co. Ltd., Campa area near Al-Kair mosque, Taiz. Tel.: +967-4-231610/232033, Fax: +967-4-219869. **Zimbabwe:** J.D.Distributors, P.O.Box 226, 17 Bessemer Road, Graniteside, Harare Tel.: +263-4-753913-7, Fax: 753918.



WARRANTY REGISTRATION CARD

YOUR NAME/الإسم _____

YOUR ADDRESS/العنوان _____

POSTCODE/الرمز البريدي _____

DATE OF PURCHASE/تاريخ الشراء _____

DEALER'S NAME & ADDRESS/إسم وعنوان البائع _____

PRODUCT MODEL NO. **BX500 - BX525 - BX550**