

MANUFACTURER'S LIMITED ONE YEAR WARRANTY

LEGACY SOUND CORP. warrants this unit to be free from defective material or workmanship and will repair or replace this unit or any part thereof if it proves defective in normal use or service within one (1) years from the date of original purchase.

Our obligation under this warranty is limited to repairing or replacing, at our discretion, the defective instrument or any part thereof when it is returned, transportation prepaid to the Legacy Service Center at the address below. This warranty will be considered void if the unit has been tampered with, improperly serviced, subjected to abuse or misuse or if installed in a commercial vehicle. This warranty does not cover accidental damage. When returning this unit for service, please include \$15.00 for return postage and handling. Send your unit to:

IMPORTANT: Pack carefully in original carton if possible. We are not responsible for damage incurred in returning items for repair. A letter stating your exact street address, daytime phone number, and the problem you are experiencing should be included. You must also enclose a copy of the original receipt as proof of date of purchase.

LEGACY SERVICE CENTER
1600 63rd Street
Brooklyn, NY 11204

FOR YOUR PROTECTION

Completely and immediately mail the Product Registration Card so that we may contact you directly in the event a safety notification is issued in accordance with the 1972 Consumer Product Safety Act, or for other reasons Legacy may deem necessary.

TECHNICAL SUPPORT HOTLINE

Our technical department will gladly answer any questions you may have about our products. They cannot, however tell you the status of a repair, or handle other customer service situations.

1-800-934-2277

Monday through Thursday, 9AM to 5PM
Friday 9AM to 2PM Eastern.

LEGACY®
www.legacycaraudio.com



LEGACY®

American
LEGACY



LA-589
LA-689
LA-789
LA-989
LA-1089
LA-1889
LA-2389
LA-2889
LA-1400
LA-2001D

HIGH SPEED
CAR AMPLIFIER

USER'S MANUAL

congratulations...

Congratulations on your purchase of an American series amplifier. You have purchased a quality product designed and engineered to give you many years of uncompromised musical service. American series amplifiers are designed with the latest technology available, which provides headroom for even the most demanding peaks and dynamic ranges found on modern CD's and recordings.

table of contents

| | | | |
|-------------------------------|-------|--|-------|
| features and specifications | 2-9 | high level input connections | 17 |
| LA-1400/LA-2001D | | LA-689/LA-1089 | |
| LA-589/LA-789/LA-989 | | system wiring speaker connections | 18 |
| LA-1889/LA-2389/LA-2889 | | LA-589/LA-789/LA-989 | |
| LA-689/LA-1089 | | LA-1889/LA-2389/LA-2889 | |
| electrical connections | 10-11 | mono input connections | 19 |
| LA-1400/LA-2001D | | LA-689/LA-1089 | |
| LA-589/LA-789/LA-989 | | speaker connections | 20-21 |
| LA-1889/LA-2389/LA-2889 | | LA-689/LA-1089 | |
| LA-689/LA-1089 | | speaker wiring | 22 |
| stereo/mono input connections | 12-15 | LA-1400/LA-2001D | |
| LA-589/LA-789/LA-989 | | mounting and installation | 23 |
| LA-1889/LA-2389/LA-2889 | | protection circuitry and troubleshooting | 24 |
| 2/4 channel input connections | 16 | precautions | 25 |
| LA-689/LA-1089 | | | |

features and specifications

MONO BLOCK AMPLIFIER LA-1400 • LA-20010

- power supplies** Stiffly regulated PWM power supplies. MOSFET switches maintain rated power over a wide range of battery voltages.
- sub sonic control** When the sub sonic selector switch is in "ON" mode, this filter control permits continuously variable adjustment from 10 to 100Hz.
- bass boost level control** This control permits adjustment of the bass level up to an increase of approximately up to 18dB.
- crossover low pass filter** Adjustable from 20Hz to 250Hz with a slope of 24dB per octave. This allows for the adjustment of the upper point of the frequency bandwidth and the respective subwoofer.
- protection circuitry** Protection against thermal, overload and short circuit conditions.

| | | |
|--------------------------------------|---------------------------------|-------------------|
| output power @ 14.4v DC, 50Hz | LA-1400 | LA-20010 |
| RMS Power at @ 4 Ohms | 175W MONO | 260W MONO |
| RMS Power at @ 2 Ohms | 275W MONO | 385W MONO |
| Maximum Power Output | 2000W MONO | 3000W MONO |
| frequency response | — 20 Hz-250 Hz (±3dB) — | |
| input impedance | — 10K Ohms — | |
| input sensitivity | — 200mV-6V Adjustable — | |
| power supply voltage | 14.4V OC Neg. Ground (10.5-16V) | |
| min speaker impedance | 2-4 Ohms | 1-4 Ohms |
| T.H.D | — 0.1% — | |
| S/N ration | — >90dB — | |
| bass boost | — 0 ~ +18dB — | |
| sub sonic filter | — 10-100Hz — | |
| fuse | 40A | 50A |
| dimensions (W x H x L) | | |
| mm | 273 x 43 x 305 | 273 x 43 x 330 |
| Inches | 10.74 x 1.69 x 12 | 10.74 x 1.69 x 13 |

features and controls

MONO BLOCK AMPLIFIER LA-1400 • LA-20010

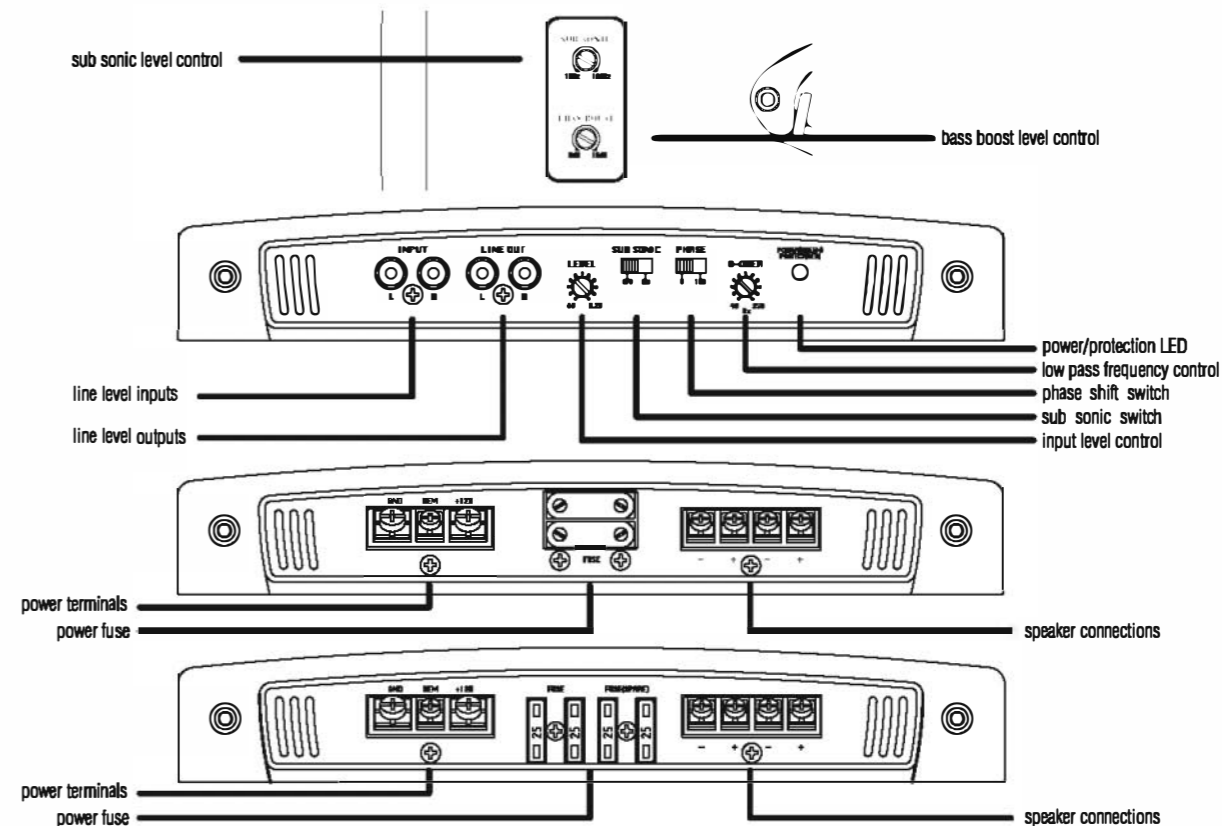

features and specifications

2 ch amp LA-589 • LA-789 • LA-989

- crossover mode selector** When used with normal, full range system, set this switch to "FULL". If you wish to use the internal crossover to power a driver or specific frequency range, use the "LPF" or "HPF" for the "LOWPASS" OR "HIGHPASS" settings.
- input level controls** Enables the matching of Input levels to the output levels from head unit (or other signal source). The input sensitivity of adjustment ranges from 6V to 200mV.
- crossover frequency control** When crossover mode selector is in HIGHPASS mode, this control sets the lower frequency limit for audio program sent to the speakers. When crossover mode selector is in LOWPASS mode, this control sets the upper frequency limit for audio program sent to the speakers. The crossover is continuously variable adjustment from 40 to 250 Hz.
- bass boost selector** This selector switch permits the bass level an increase of 18dB. (LA-589/789/989)
- sub sonic control** When the sub sonic selector switch is in "ON" mode, this filter control permits continuously variable adjustment from 10 to 100Hz. (LA-1889/2389/2889)
- low level input** This amp features RCA type jacks for high Impedance Input. Use these with car stereo output which uses RCA type connector cables.
- high level input** If your car stereo jacks are not RCA type output, use the high-low level input adaptor to connect the speaker output leads of car stereo and the RCA input jacks of amp.
- AUX line outputs** This amp features RCA jacks for AUX line outputs. Use these for unlimited system expansion to the next AMERICAN.
- power LED** This Indicator is illuminated in GREEN when power is applied.
- protection LED** This indicator is illuminated in RED when the built-in protection circuitry is activated.
- power fuse** The fuse protects the amplifier and your car's electrical system from short circuit conditions.
- power terminals** Use these connectors to deliver power, ground, and remote turn-on control to the amplifier.
- speaker connectors** These terminals are to guarantee high conductivity and minimum signal loss.

| output power @ 14.4V DC, 1KHz | LA-589 | LA-789 | LA-989 |
|-----------------------------------|---------------------------------|---------------------|-------------------|
| RMS Power @ 4 Ohms | 35 Watts x 2 | 50 Watts x 2 | 100 Watts x 2 |
| THD @ 4 Ohms | 50 Watts x 2 | 75 Watts x 2 | 150 Watts x 2 |
| RMS Power @ 2 Ohms | 50 Watts x 2 | 75 Watts x 2 | 150 Watts x 2 |
| THD @ 2 Ohms | 75 Watts x 2 | 100 Watts x 2 | 200 Watts x 2 |
| Maximum Power Output | 400 Watts x 2 | 500 Watts x 2 | 1000 Watts x 2 |
| Bridged Power at 4 Output | 800 Watts x 1 | 1000 Watts x 1 | 2000 Watts x 1 |
| frequency response | _____ | 15 Hz-30 KHz | _____ |
| input impedance | _____ | 10K Ohms | _____ |
| low level inputs | _____ | 200mV-6V Adjustable | _____ |
| input sensitivity | _____ | >95dB | _____ |
| S/N ration | _____ | >65dB | _____ |
| channel separation | _____ | 40 Hz-250 Hz | _____ |
| crossover filters | _____ | 40 Hz-250 Hz | _____ |
| low Pass | _____ | 0 / +18dB | _____ |
| high Pass | _____ | _____ | _____ |
| bass boost | _____ | _____ | _____ |
| matching speaker impedance | _____ | 2-4 Ohms | _____ |
| stereo mode | _____ | 4-8 Ohms | _____ |
| bridged mode | _____ | _____ | _____ |
| maximum current draw | 20A | 20A | 30A |
| power supply voltage | 14.4V DC Neg. Ground (10.5-16V) | | |
| dimensions (W x H x L) | 273 x 43 x 190 | 273 x 43x 228 | 273 x 43x 305 |
| inches | 10.74 x 1.69 x 7.5 | 10.74 x 1.69 x 9 | 10.74 x 1.69 x 12 |

features and controls

2 ch amp LA-589 • LA-789 • LA-989

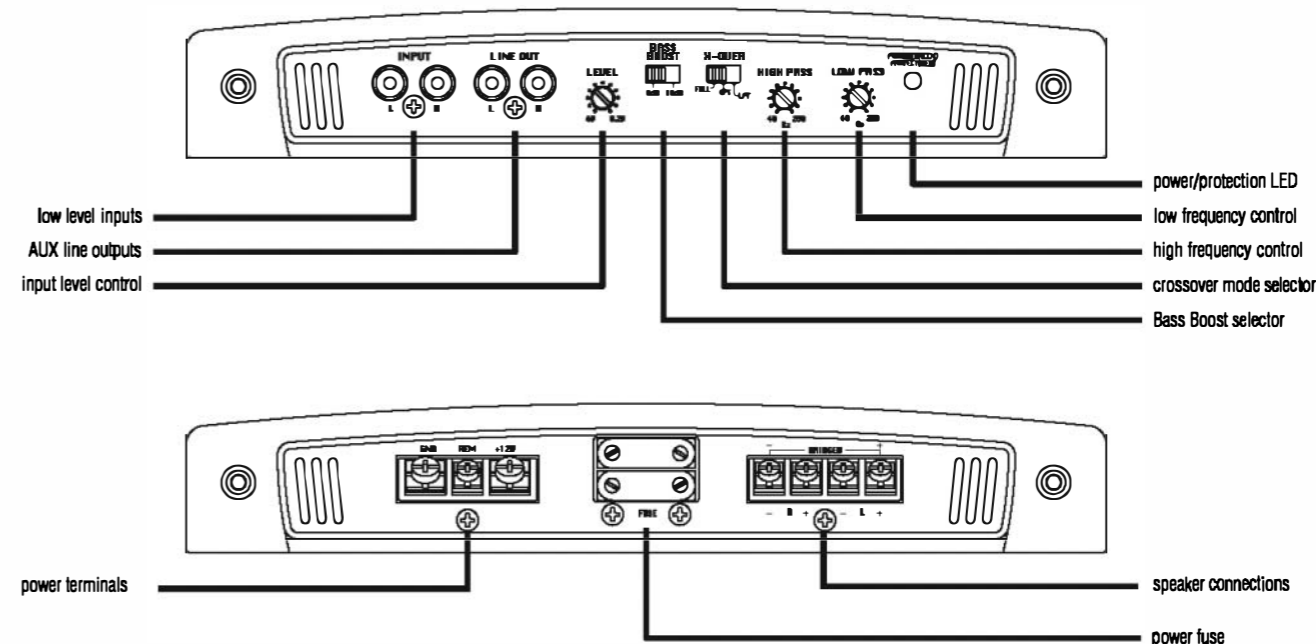

features and specifications

2 ch amp LA-1889 • LA-2389 • LA-2889

- crossover mode selector** When used with normal, full range system, set this switch to "FULL". If you wish to use the internal crossover to power a driver or specific frequency range, use the "LPF" or "HPF" FOR the "LOWPASS" OR "HIGHPASS" settings.
- input level controls** Enables the matching of input levels to the output levels from head unit (or other signal source). The input sensitivity of adjustment ranges from 6V to 200mV.
- crossover frequency control** When crossover mode selector is in HIGHPASS mode, this control sets the lower frequency limit for audio program sent to the speakers. When crossover mode selector is in LOWPASS mode, this control sets the upper frequency limit for audio program sent to the speakers. The crossover is continuously variable adjustment from 40 to 260 Hz.
- sub sonic filter switch** This selector switch permits the bass level an increase of 18dB.
- bass boost level control** This control permits adjustment of the bass level up to an increase of approximately up to 18dB.
- sub sonic control** When the sub sonic selector switch is in "ON" mode, this filter control permits continuously variable adjustment from 10 to 100Hz.
- low level input** This amp features RCA type jacks for high impedance input. Use these with car stereo output which uses RCA type connector cables.
- high level input** If your car stereo jacks are not RCA type output, use the high-low level input adaptor to connect the speaker output leads of car stereo and the RCA input jacks of amp.
- AUX line outputs** This amp features RCA jacks for AUX line outputs. Use these for unlimited system expansion to the next AMERICAN.
- power LED** This indicator is illuminated in GREEN when power is applied.
- protection LED** This indicator is illuminated in RED when the built-in protection circuitry is activated.
- power fuse** The fuse protects the amplifier and your car's electrical system from short circuit conditions.
- power terminals** Use these connectors to deliver power, ground, and remote turn-on control to the amplifier.
- speaker connectors** These terminals are to guarantee high conductivity and minimum signal loss.

| output power @ 14.4v DC, 1KHz | LA-1889 | LA-2389 | LA-2889 |
|-----------------------------------|---------------------------------|-------------------|-------------------|
| RMS Power @ 4 Ohms | 150 Watts x 2 | 200 Watts x 2 | 300 Watts x 2 |
| THD @ 4 Ohms | 250 Watts x 2 | 300 Watts x 2 | 450 Watts x 2 |
| RMS Power @ 2 Ohms | 250 Watts x 2 | 300 Watts x 2 | 450 Watts x 2 |
| THD @ 2 Ohms | 300 Watts x 2 | 400 Watts x 2 | 650 Watts x 2 |
| Maximum Power Output | 1500 Watts x 2 | 2000 Watts x 2 | 2500 Watts x 2 |
| Bridged Power at 4 Output | 3000 Watts x 1 | 4000 Watts x 1 | 5000 Watts x 1 |
| frequency response | 15 Hz-30 KHz | | |
| input impedance | 10K Ohms | | |
| low level inputs | 10K Ohms | | |
| input sensitivity | 200mV-6V Adjustable | | |
| low level inputs | 200mV-6V Adjustable | | |
| S/N ration | >95dB | | |
| channel separation | >65dB | | |
| crossover filters | | | |
| low Pass | 40 Hz-250 Hz | | |
| high Pass | 40 Hz-250 Hz | | |
| bass boost | 0 ~ +18dB | | |
| sub sonic filter | 10-100Hz | | |
| matching speaker impedance | | | |
| stereo mode | 2-4 Ohms | | |
| bridged mode | 4-8 Ohms | | |
| maximum current draw | 40A | 50A | 60A |
| power supply voltage | 14.4V DC Neg. Ground (10.5-16V) | | |
| dimensions (W x H x L) | | | |
| mm | 273 x 43 x 381 | 273 x 43 x 432 | 273 x 43 x 532 |
| inches | 10.74 x 1.69 x 15 | 10.74 x 1.69 x 17 | 10.74 x 1.69 x 21 |

features and controls

2 ch amp LA-1889 • LA-2389 • LA-2889

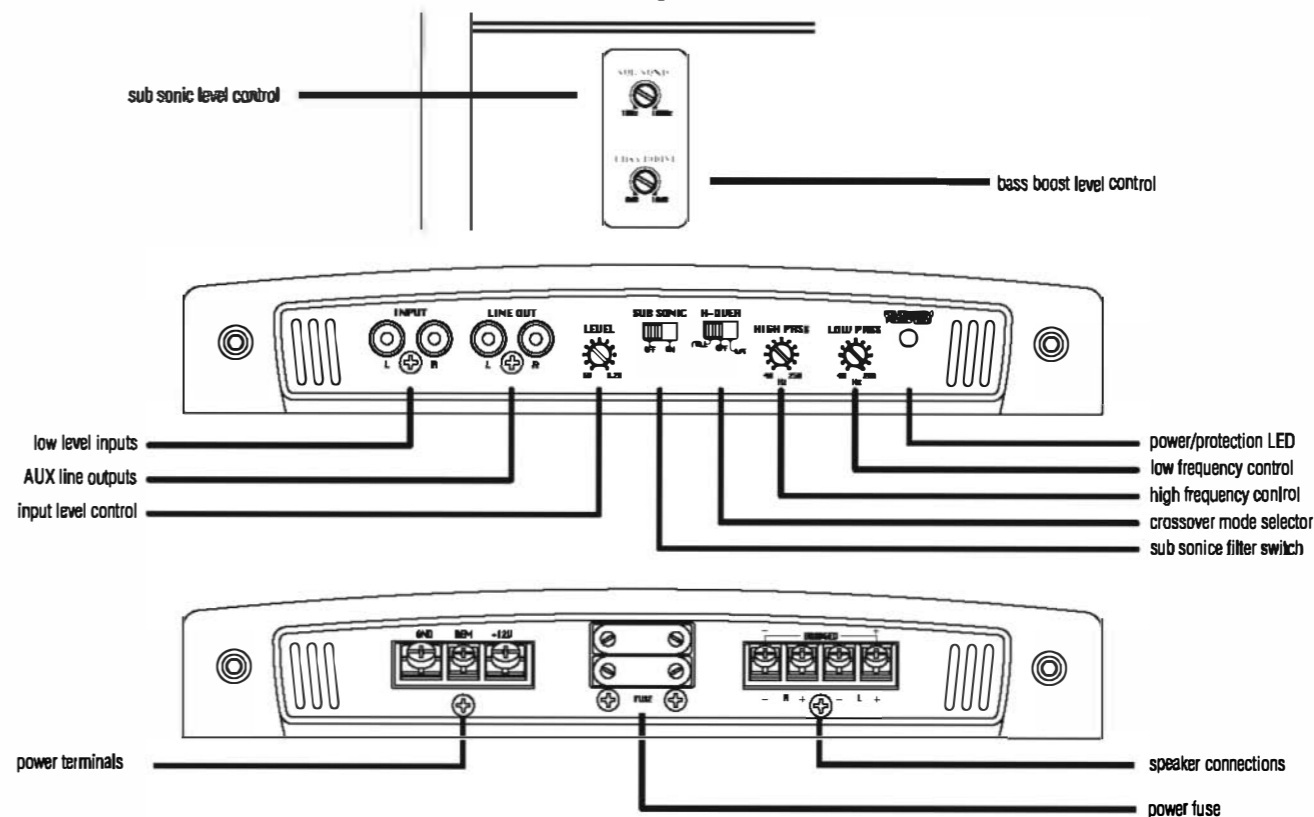

features and specifications

4 ch amp LA-689 • LA-1089

- crossover mode selector** When used with normal, full range system, set this switch to "FULL". If you wish to use the internal crossover to power a driver of specific frequency range, use the "LPF" or "HPF" for the "LOWPASS" OR "HIGHPASS" settings.
- input level controls** Enables the matching of input levels to the output levels from head unit (or other signal source). The input sensitivity of adjustment ranges from 6V to 200mV.
- crossover frequency control** When crossover mode selector is in HIGHPASS mode, this control sets the lower frequency limit for audio program sent to the speakers. When crossover mode selector is in LOWPASS mode, this control sets the upper frequency limit for audio program sent to the speakers. The crossover is continuously variable adjustment from 40 to 250 Hz.
- bass boost selector** This selector switch permits the bass level an increase of 18dB.
- low level input** This amp features RCA type jacks for high impedance input. Use these with car stereo output which uses RCA type connector cables.
- high level input** If your car stereo jacks are not RCA type output, the high-low level input adaptor to connect the speaker output leads of car stereo and the RCA input jacks of amp.
- AUX line outputs** This amp features RCA jacks for AUX line outputs. Use these outputs. Use these for unlimited system expansion to the next AMERICAN.
- power LED** This indicator is illuminated in GREEN when power is applied.
- protection LED** This indicator is illuminated in RED when the built-in protection circuitry is activated.
- power fuse** The fuse protects the amplifier and your car's electrical system from short circuit conditions.
- power terminals** Use these connectors to deliver power, ground, and remote turn-on control to the amplifier.
- speaker connectors** These terminals are to guarantee high conductivity and minimum signal loss.

| | LA-689 | LA-1089 |
|--------------------------------------|---------------------------------|-------------------|
| output power @ 14.4v DC, 1KHz | | |
| RMS Power @ 4 Ohms | 50 Watts x 4 | 100 Watts x 4 |
| THD @ 4 Ohms | 75 Watts x 4 | 150 Watts x 4 |
| RMS Power @ 2 Ohms | 75 Watts x 4 | 150 Watts x 4 |
| THD @ 2 Ohms | 100 Watts x 4 | 200 Watts x 4 |
| Maximum Power Output | 500 Watts x 4 | 1000 Watts x 4 |
| Bridged Power at 4 Output | 1000 Watts x 2 | 2000 Watts x 2 |
| frequency response | 15 Hz-30 KHz | |
| input impedance | 10K Ohms | |
| low level in pole | 10K Ohms | |
| input sensitivity | 200mV-6V Adjustable | |
| low level inputs | 200mV-6V Adjustable | |
| S/N ration | >95dB | |
| channel separation | >65dB | |
| crossover filters | | |
| low Pass | 40 Hz-250 Hz | |
| high Pass | 40 Hz-250 Hz | |
| bass boost | 0 / +18dB | |
| matching speaker impedance | | |
| stereo mode | 2-4 Ohms | |
| bridged mode | 4-8 Ohms | |
| maximum current draw | 30A | 50A |
| power supply voltage | 14.4V DC Neg. Ground (10.5-16V) | |
| dimensions (W x H x L) | | |
| mm | 273 x 43 x 355 | 273 x 43 x 432 |
| inches | 10.74 x 1.69 x 14 | 10.74 x 1.69 x 17 |

features and controls

4 ch amp LA-689 • LA-1089

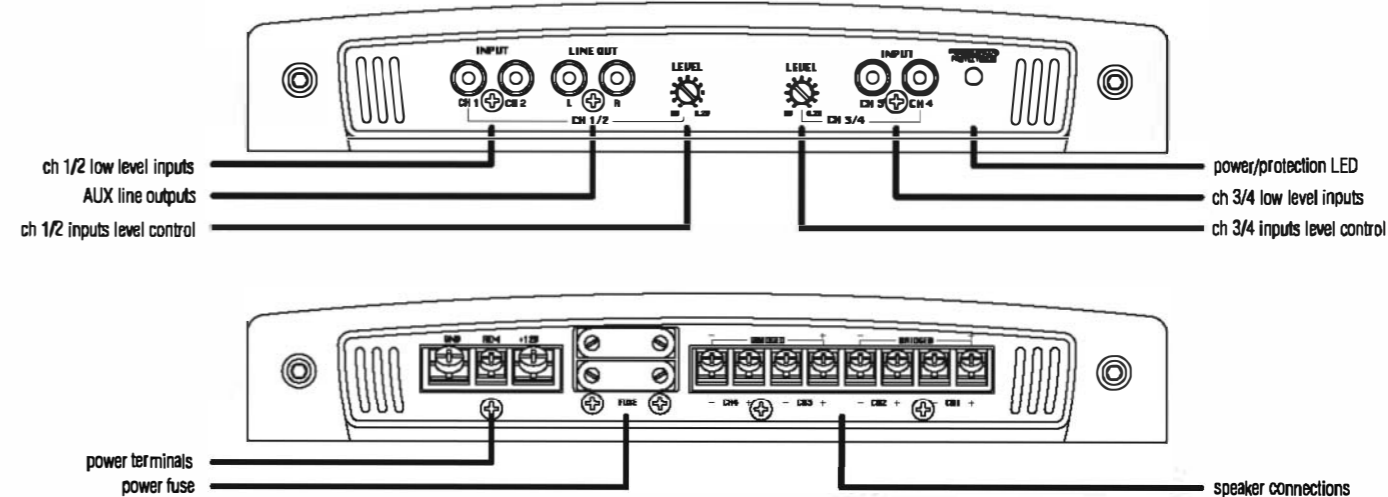
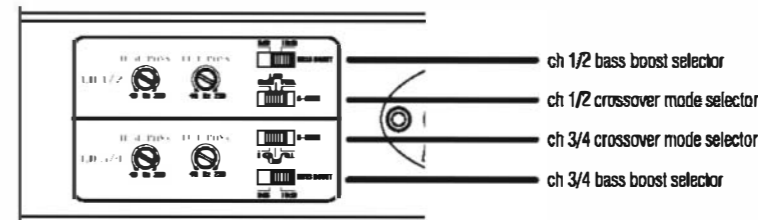

electrical connections

2 ch amp LA-589 • LA-789
LA-989 • LA-1889
LA-2389 • LA-2889

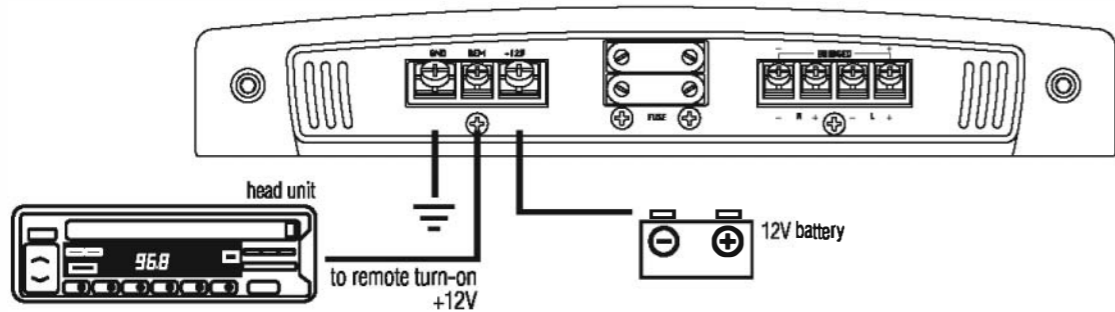

electrical connections

4 ch amp LA-689 • LA-1089

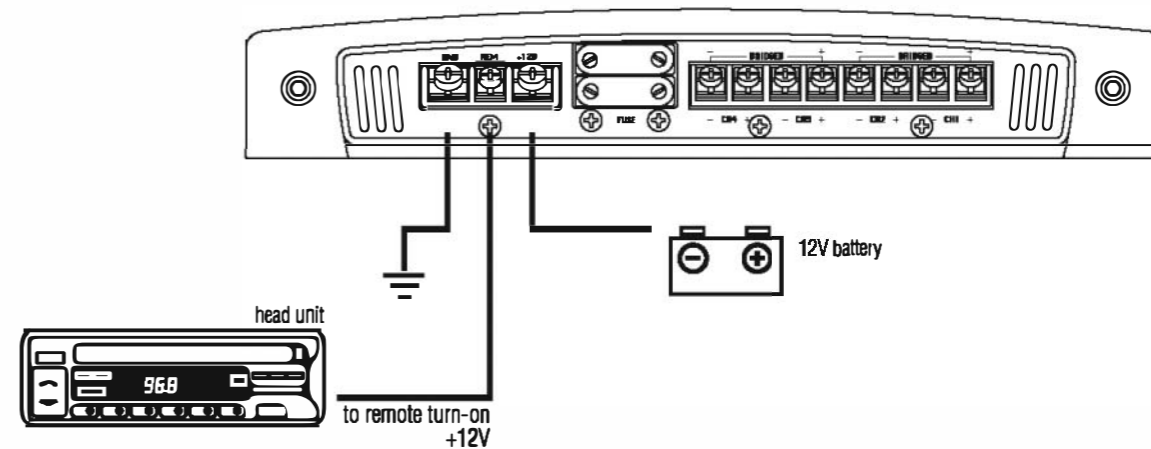

stereo input connections

2 ch amp LA-589 • LA-789 • LA-989

using low level inputs

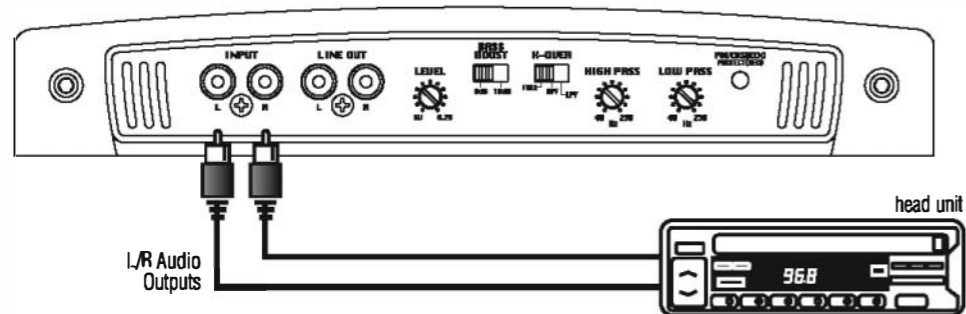

using high level inputs

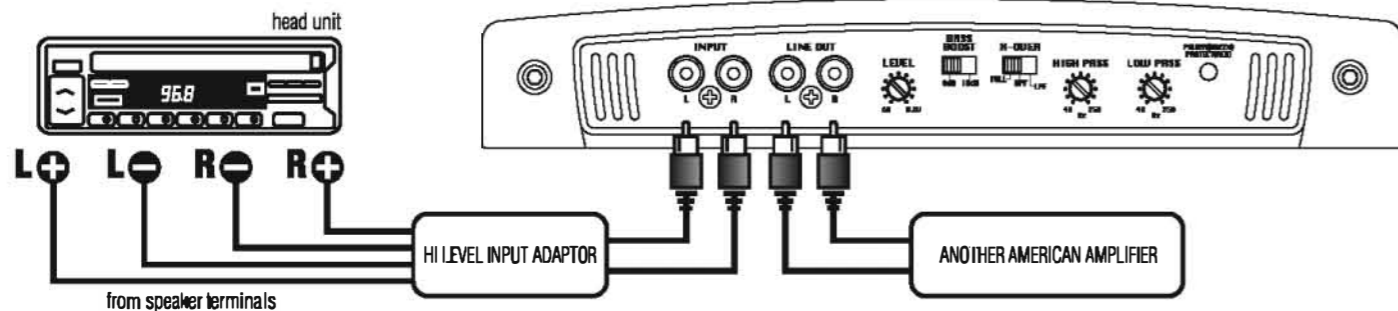

mono input connections

2 ch amp LA-589 • LA-789 • LA-989

using low level inputs

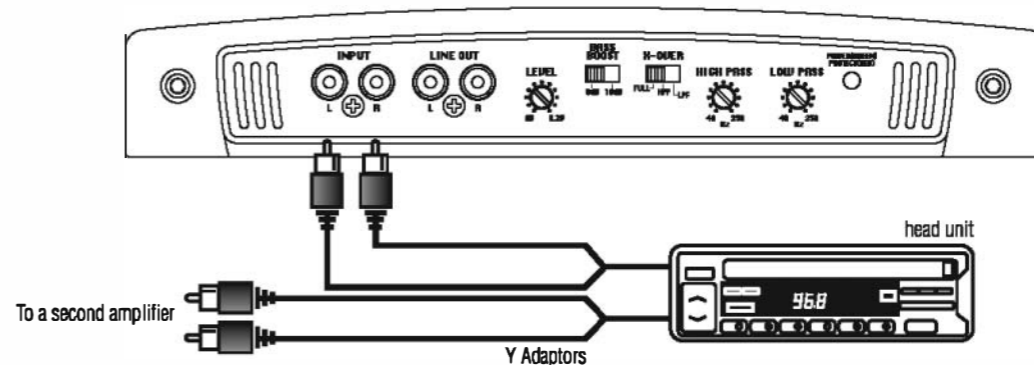

using high level inputs

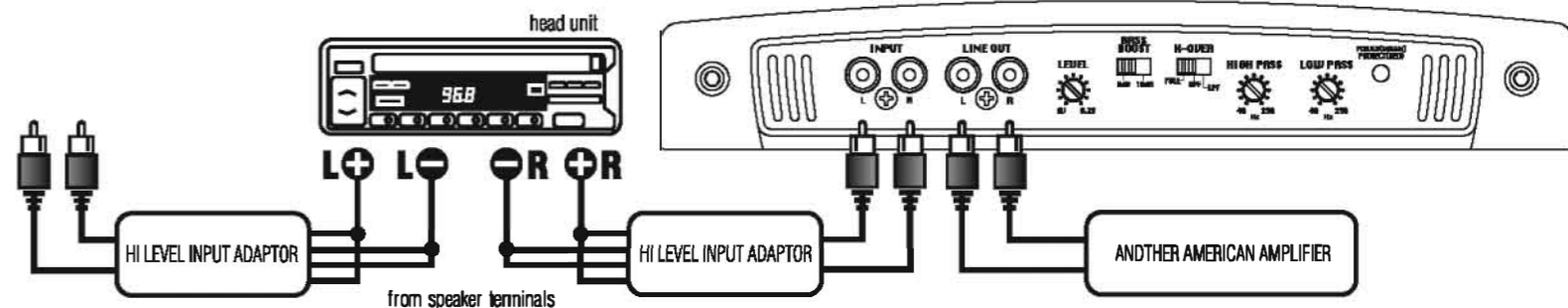

stereo input connections

2 ch amp LA-1889 • LA-2389 • LA-2889

using low level inputs

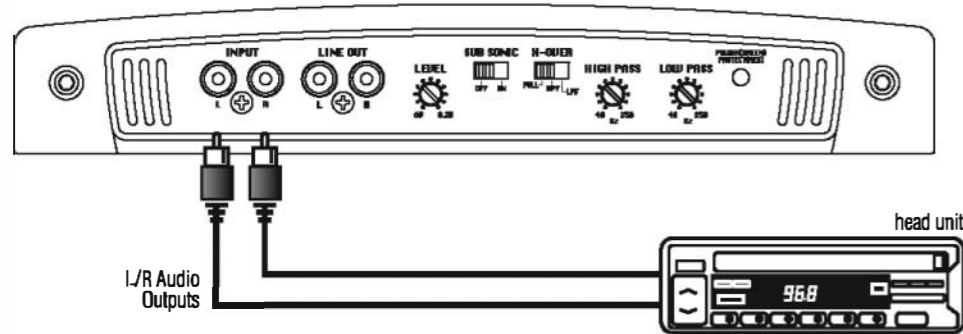

using high level inputs

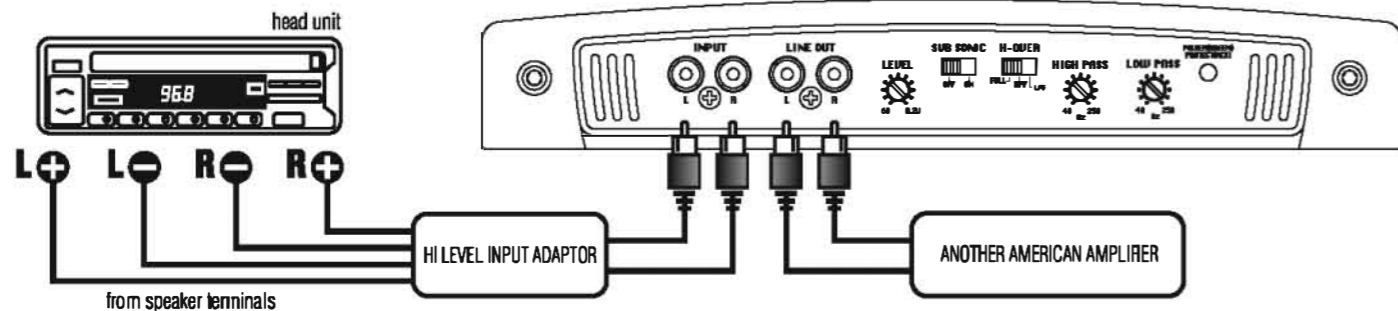

mono input connections

2 ch amp LA-1889 • LA-2389 • LA-2889

using low level inputs

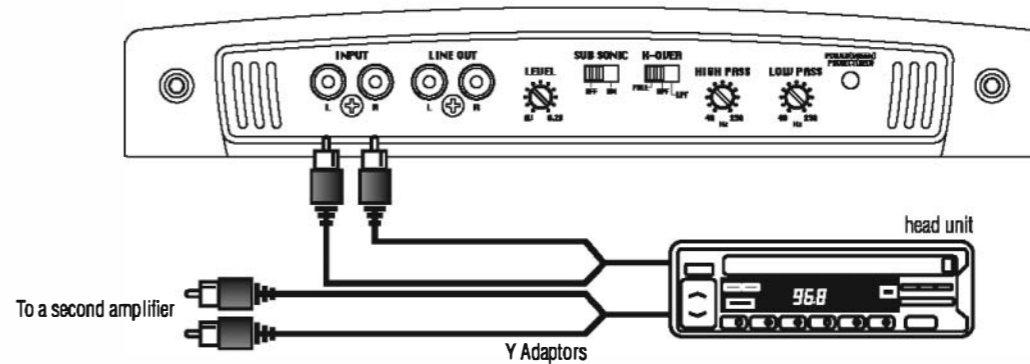

using high level inputs

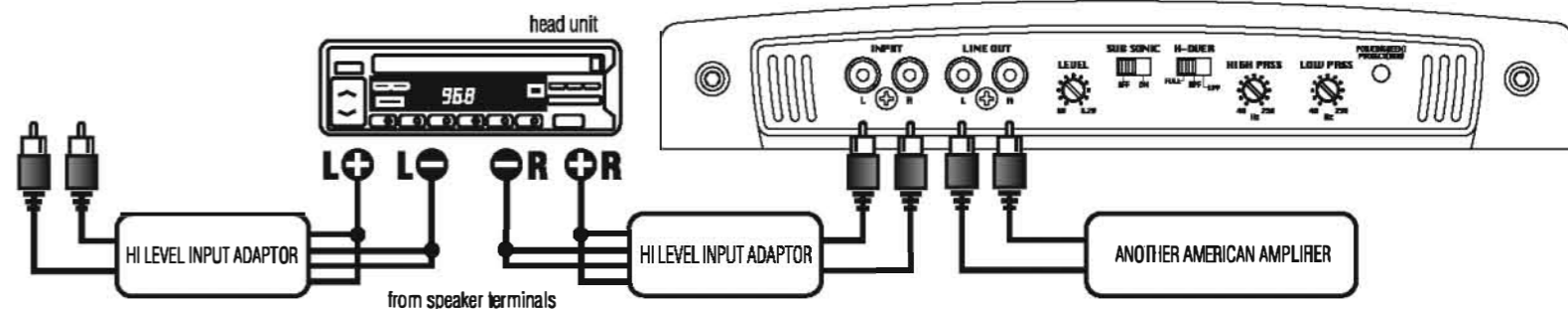

2/4 channel input connections

4 ch amp LA-689 • LA-1089

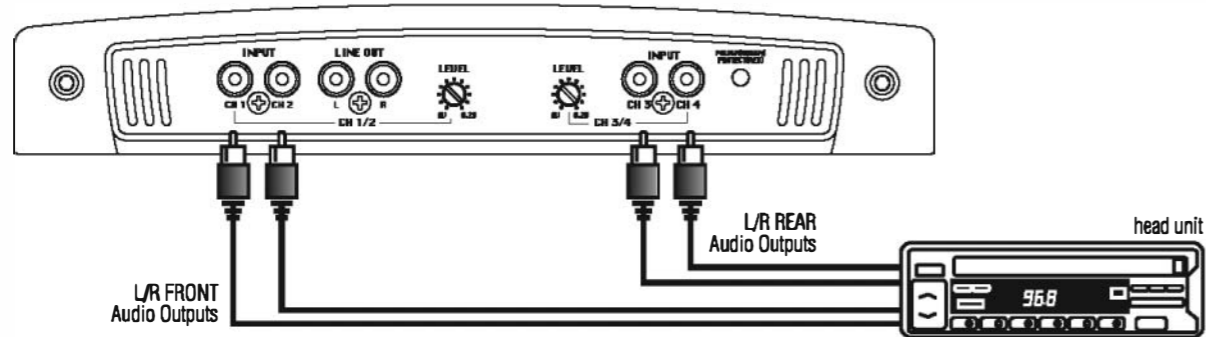

2 CH input connections using low level inputs

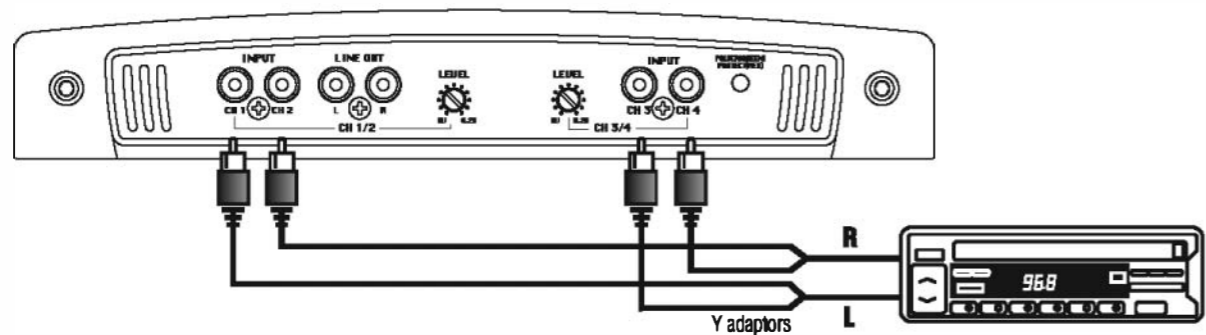

high level input connections

4 ch amp LA-689 • LA-1089

4 CH Floating ground connections

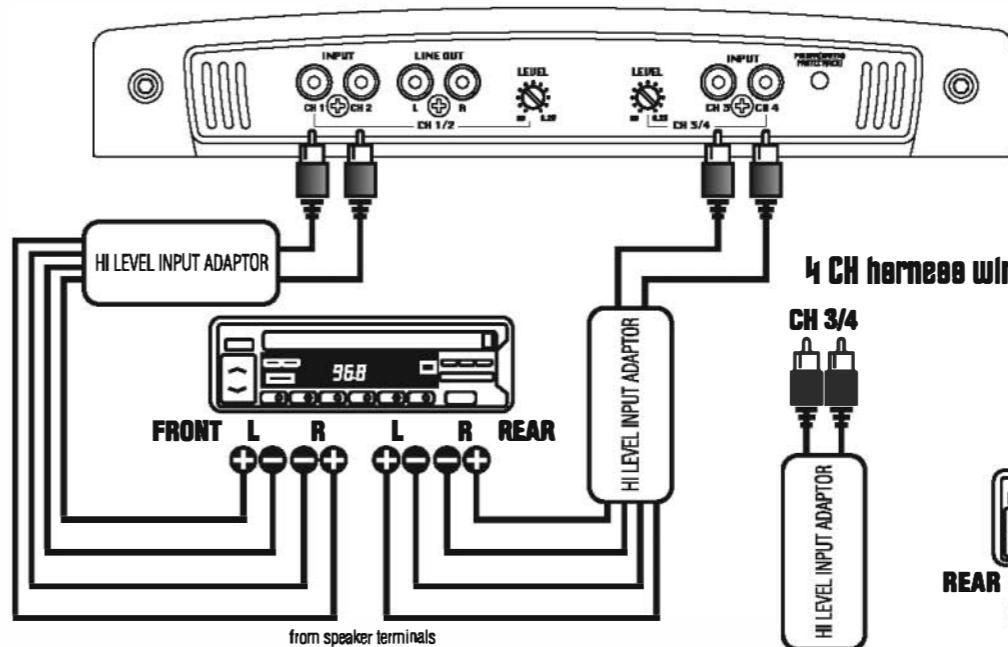

4 CH harness wiring for common ground connections

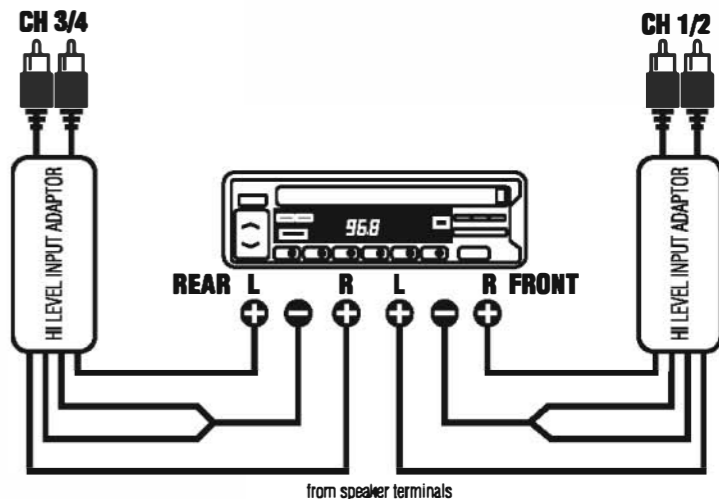

speaker connections

2 ch amp LA-589 • LA-789 • LA-989
LA-1889 • LA-2389 • LA-2889

Stereo Output Mode

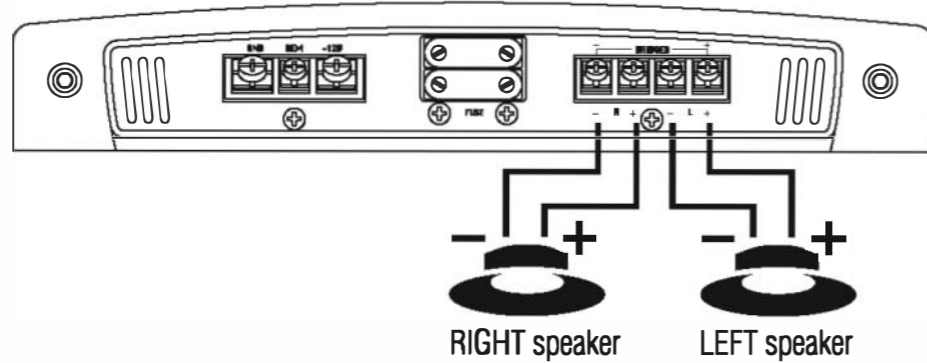

Bridged Mono Output Mode

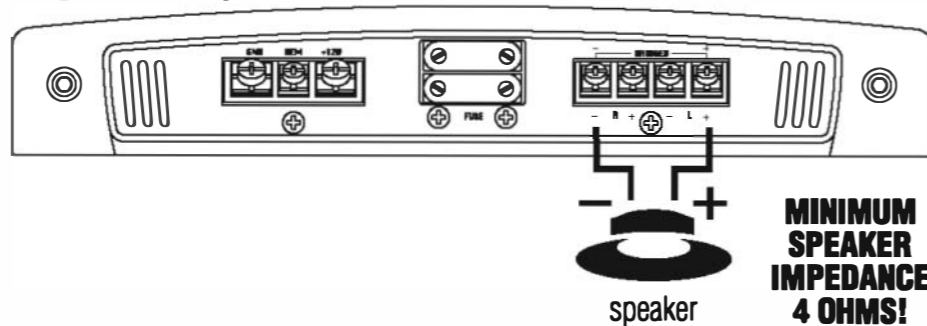

mono input connections

4 ch amp LA-689 • LA-1089

4 CH mono Input connections using low level inputs

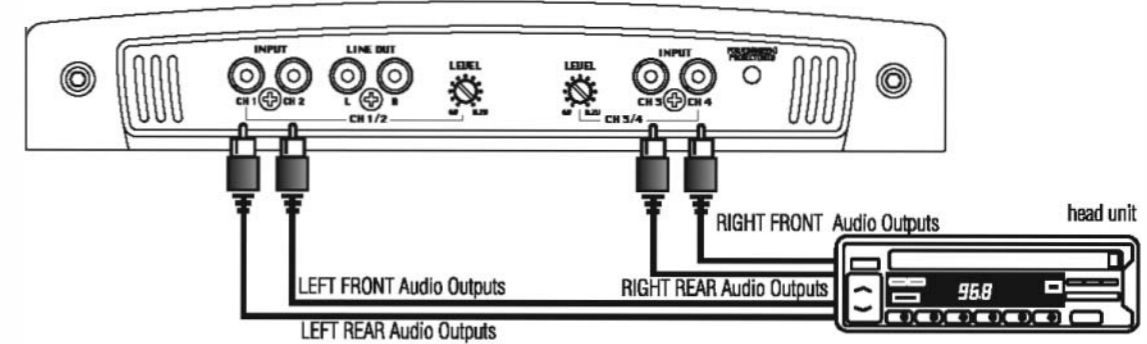

2 CH mono Input connections using low level inputs

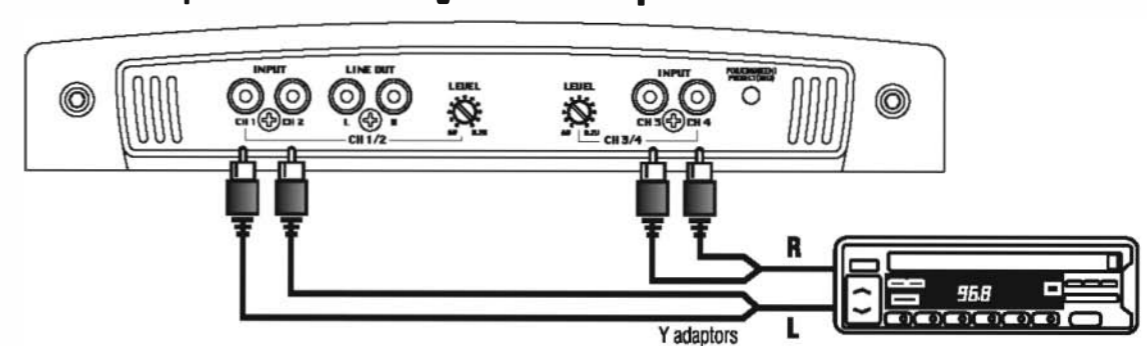

speaker connections

4 ch amp LA-689 • LA-1089

4 CH Output Mode

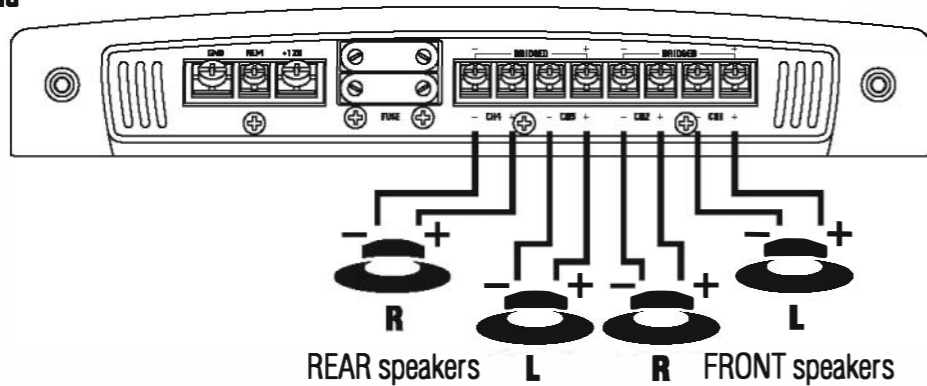

Bridged Dual Mono Output Mode

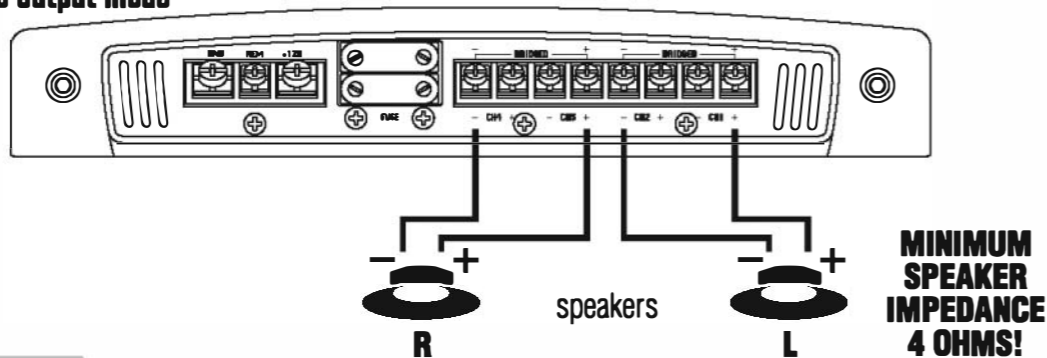

speaker connections

4 ch amp LA-689 • LA-1089

2 CH Stereo Output Mode with Mono Bridged Subwoofer Output

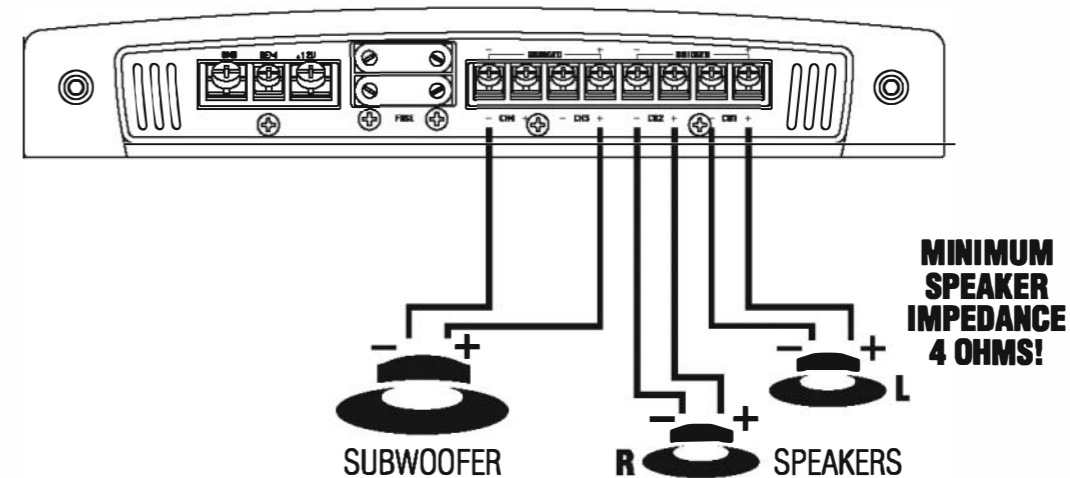

system wiring

MONO BLOCK AMPLIFIER LA-1400 • LA-200ID

mounting and installation

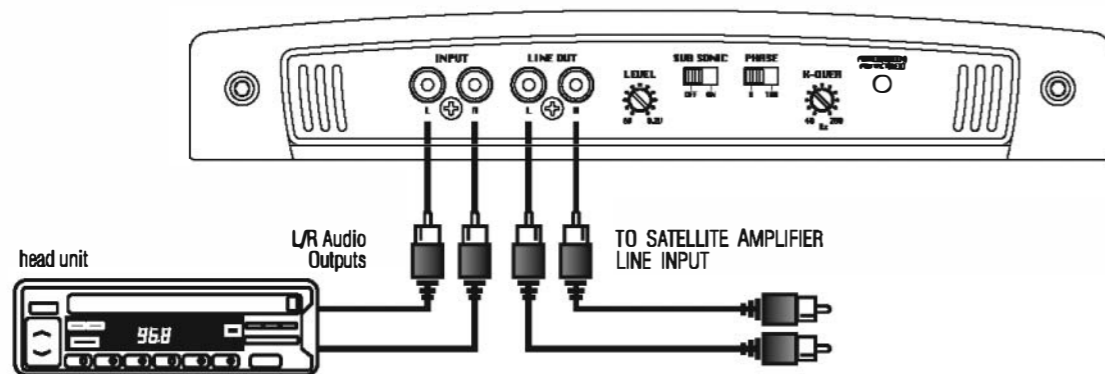

SPEAKER OUTPUT CONNECTION

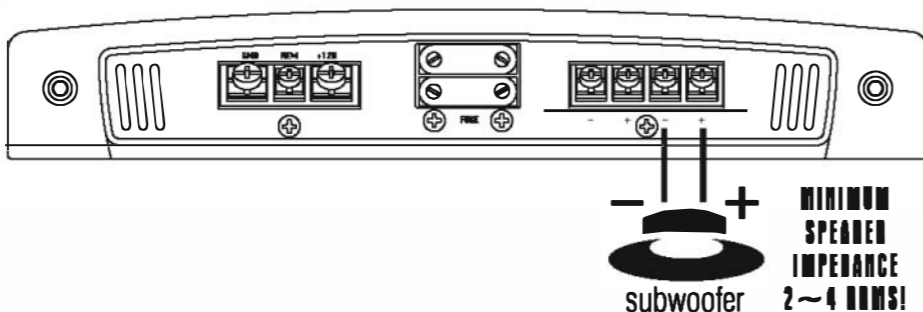

mounting

Your new American LEGACY amplifier comes complete with all required mounting hardware. When determining a suitable location in your vehicle for the amp, please remember that it is a high-power electronic device capable of generating high heat.

For this reason, **always choose a location in your vehicle which has low vibration, adequate ventilation, a minimum of dust, and no moisture.** Be sure to mount the amp in such a manner as to allow reasonable airflow over the cooling fins.

Mark the location for the mounting screw holes by positioning the amp where you wish to install it and use a scribe (or one of the mounting screws) inserted in each of the mounting holes to mark the mounting surface. If the mounting surface is carpeted, measure the hole centers and mark with a felt tip pen.

Before attempting to drill the mounting holes, take note of any wires, lines or other devices in your vehicle which may be located behind the mounting surface! Then drill pilot holes in the mounting surface for the mounting screws and insert them. Tighten the screws securely.

wiring tips

When making electrical connections to your amplifier, please observe the following:

Use at least 8 gauge wire for power and ground connections.

Wire the amplifier directly to the car battery.

For the ground connection, use the shortest possible wire to a good chassis ground point.

Wire the Remote connection to the auto start lead of your head unit, equalizer or power antenna.

fuses

About power fuses:

American LEGACY Series amplifiers feature built-in fuse systems. These fuses protect both the amplifier and the electrical system in your vehicle from fault conditions. If you ever need to replace the fuse in your American LEGACY Series amp, use a fuse of exactly the same type and rating. A different type or rating of fuse may result in damage or fire.

protection circuitry

The built-in protection circuitry in the American Legacy Series amplifiers will disable the amplifier if it senses an input overload, a speaker short circuit, or extreme temperature conditions.

When the protection circuit is activated by any of these conditions, the Protection LED will be illuminated.

If this occurs, carefully inspect the system to determine the source of the problem.

- If the shutdown was a result of a thermal overload condition, allow the amplifier to cool down before attempting to restart it.
- If the shutdown was a result of an input overload, or speaker short circuit, be sure to correct the condition before restarting.

The amplifier can be restarted by turning the remote power OFF and then ON again.

No output.

Confirm that all terminal strip connections are secure and tight.

Check both in-line and built-in fuses. Both the +12V and the Remote terminals must have +12v referenced to chassis ground.

Confirm that the audio signal source (car radio, equalizer, etc.) is connected and is supplying output signal. To check if the amp is supplying signal, unplug the cables from the signal source (but leave them plugged into the amp). Briefly tap the center pin of each of the disconnected RCA plugs with your finger. This should produce a noise (feedback) in your speakers.

Only one channel works.

Confirm that all terminal strip connections are secure and tight.

Check the Balance control on the head unit (or other source) to verify that it is set to its midpoint.

If you are using the Low Level RCA input, reverse the input plugs at the amplifier (i.e., switch the L with the R). If the channels which is silent switches to the other side, the problem is either in the head unit/other source or the connecting cables.

Weak output.

Readjust the Input Level Control(s) to better suit the input signal.

Noise in the audio.

If the noise is a "whine" whose pitch follows the engine speed, confirm that the amplifier and any other signal sources (head unit, etc.) are properly grounded.

If the noise is a "clicking" or "popping" noise whose rate follows the engine speed, this usually means that the vehicle is equipped with resistor spark plugs and wires, or that the ignition is in need of service.

Check the routing of the speaker and input wires to make sure they are not adjacent to wires which interconnect lights and other accessories.

If the above steps fail to improve or clear noise interference, the system should be checked by a professional mobile audio installer.

precautions

Do not operate the amplifier when it is unmounted. Attach all audio system components securely within the automobile to prevent damage, especially in an accident.

Do not mount this amplifier so that the wire connections are unprotected, or in a pinched condition, or likely to be damaged by nearby objects.

Before making or breaking power connections in your system, disconnect the vehicle battery. Confirm that your head unit or other equipment is turned off while connecting the input jacks and speaker terminals.

If you need to replace the power fuse, do so only with a fuse identical to that supplied with the amplifier. Using a fuse of a different type or rating may result in damage that isn't covered in the manufacturer's warranty.

