



Room Air Conditioners

Safety Instructions 2, 3

Operating Instructions 4-9

Care and Cleaning

Air Filter 11

Front Grille 10

Grille and Case 10

Outdoor Coils 10

Installation Instructions

Before You Begin 12, 13

Installing a J-Model in
an Existing Wall Case 14

Through-the-Wall
Installation 15

Window Installation
(Optional) 16-21

Troubleshooting Tips 22

Normal Operating Sounds 22

Consumer Support

Consumer Support Back Cover

Warranty 23

*ENERGY STAR® labeled product



As an ENERGY STAR® partner, GE has determined that this product meets the ENERGY STAR® guidelines for energy efficiency.

Write the model and serial numbers here:

Model # _____

Serial # _____

Find these numbers on a label on the front of the base pan behind the front grille.

Cool Only:	AJCM 08, 10	ACD*
	AJCM 10, 12	DCD*
	AJCQ 06	LCD*
	AJCQ 08, 10, 12	ACD*
	AJCQ 09, 10, 12	DCD*
Heat/Cool:	AJEM 12	DCD
	AJEQ 06	LCD
	AJEQ 08	ACD
	AJEQ 09, 10, 12	DCD

Español

For a Spanish version of this manual, visit our Website at GEAppliances.com.

Para consultar una versión en español de este manual de instrucciones, visite nuestro sitio de internet GEAppliances.com.

Française

For a French version of this manual, visit our Website at GEAppliances.com.

Pour une version française de ce manuel d'utilisation, veuillez visiter notre site web à l'adresse GEAppliances.com.

IMPORTANT SAFETY INFORMATION. READ ALL INSTRUCTIONS BEFORE USING.



SAFETY PRECAUTIONS

⚠ WARNING! *Risk of electric shock. Can cause injury or death. For your safety, the information in this manual must be followed to minimize the risk of fire, electric shock or personal injury.*

- Use this appliance only for its intended purpose as described in this Owner's Manual.
- This air conditioner must be properly installed in accordance with the Installation Instructions before it is used.
- Never unplug your air conditioner by pulling on the power cord. Always grip plug firmly and pull straight out from the receptacle.
- Replace immediately all electric service cords that have become frayed or otherwise damaged. A damaged power supply cord must be replaced with a

new power supply cord obtained from the manufacturer and not repaired. Do not use a cord that shows cracks or abrasion damage along its length or at either the plug or connector end.

- Turn **OFF** and unplug your air conditioner before making any repairs or cleaning.

NOTE: *We strongly recommend that any servicing be performed by a qualified individual.*

- For your safety...do not store or use combustible materials, gasoline or other flammable vapors or liquids in the vicinity of this or any other appliance.
- All air conditioners contain refrigerants, which under federal law must be removed prior to product disposal. If you are getting rid of an old product with refrigerants, check with the company handling disposal about what to do.

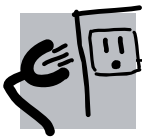

HOW TO CONNECT ELECTRICITY

⚠ WARNING! *Risk of electric shock. Can cause injury or death. This appliance must be properly grounded. Do not, under any circumstances, cut or remove the third (ground) prong from the power cord. For personal safety, this appliance must be properly grounded.*

- The power cord of this appliance is equipped with a 3-prong (grounding) plug which mates with a standard 3-prong (grounding) wall outlet to minimize the possibility of electric shock hazard from this appliance.
- Have the wall outlet and circuit checked by a qualified electrician to make sure the outlet is properly grounded.
- Power cord may include a current interrupter device. A test and reset button is provided on the plug case. The device should be tested on a periodic basis by first pressing the **TEST** button and then the **RESET** button. If the **TEST** button does not trip or if the **RESET** button will not stay engaged, discontinue use of the air conditioner and contact a qualified service technician.

- Where a 2-prong wall outlet is encountered, it is your personal responsibility and obligation to have it replaced with a properly grounded 3-prong wall outlet.

⚠ WARNING! *Risk of electric shock. Can cause injury or death.*

- The air conditioner should always be plugged into its own individual electrical outlet which has a voltage rating that matches the rating plate. This provides the best performance and also prevents overloading house wiring circuits which could cause a fire hazard from overheated wires.
- See the Installation Instructions, Electrical Requirements section for specific electrical connection requirements.

SAVE THESE INSTRUCTIONS



USE OF EXTENSION CORDS—115-Volt models only

- ⚠ **WARNING!** *Risk of electric shock. Can cause injury or death.*
 - We strongly recommend against the use of an extension cord.
 - If you must use an extension cord, it is absolutely necessary that it be a UL-listed, 14-gauge, 3-wire grounding-type appliance extension cord having a grounding-type plug and outlet and that the electrical rating of the cord be 15 amperes (minimum) and 125 volts.
- DO NOT use an extension cord with any of the 230/208-volt models.



USE OF ADAPTER PLUGS—115-Volt models only

- ⚠ **WARNING!** *Risk of electric shock. Can cause injury or death.*
 - We strongly recommend against the use of an adapter plug.
 - If you must use an adapter, where local codes permit, a **temporary connection** may be made to a properly grounded 2-prong wall outlet by use of a UL-listed adapter available at most local hardware stores.
 - The larger slot in the adapter must be aligned with the larger slot in the wall outlet to provide proper polarity in the connection of the power cord.
- When disconnecting the power cord from the adapter, always hold the adapter in place with one hand while pulling the power cord plug with the other hand. If this is not done, the adapter ground terminal is very likely to break with repeated use.
- If the adapter ground terminal breaks, **DO NOT USE** the air conditioner until a proper ground has been established.
- Attaching the adapter ground terminal to a wall outlet cover screw does not ground the appliance unless the cover screw is metal, not insulated, and the wall outlet is grounded through the house wiring. You should have the circuit checked by a qualified electrician to make sure the outlet is properly grounded.



READ AND FOLLOW THIS SAFETY INFORMATION CAREFULLY.
SAVE THESE INSTRUCTIONS

About the controls on the air conditioner—Cool Only Models

Appearance may vary.

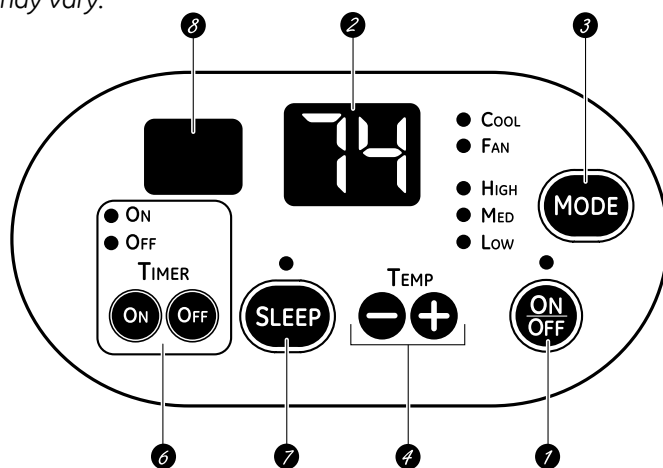

Air Conditioner Controls

Lights beside the touch pads on the air conditioner control panel indicate the selected settings.

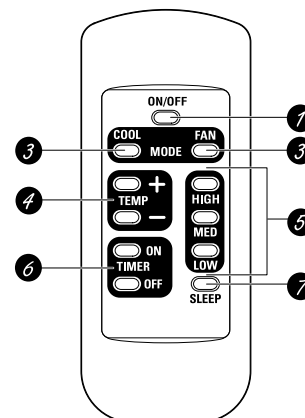

Remote Control



Controls

- 1 ON/OFF**
Turns air conditioner on and off.
- 2 Display**
Displays the temperature setting. Displays hours when setting the timer.
- 3 MODE**
On the remote control, use to set the air conditioner to **COOL** or **FAN** mode.

On the air conditioner controls, use to set **COOL** or **FAN** mode at **HIGH**, **MED** or **LOW** fan speed. Indicator lights on the air conditioner controls will show the mode and fan speed selected.
- 4 TEMP Increase + /Decrease - Pads**
Use to set temperature when in **COOL** mode.
- 5 Fan Speeds (Remote control only)**
Use to set the fan speed at **LOW**, **MED** or **HIGH**.
- 6 TIMER**
ON—When the air conditioner is off, it can be set to automatically turn on in half an hour to 24 hours at its previous setting. Each touch will set the time in half hours up to 10 and then in hours up to 24.

To cancel the On Timer, press the **ON** pad until the display time disappears.

OFF—When the air conditioner is on, it can be set to automatically turn off in half an hour to 24 hours. Each touch will set the time in half hours up to 10 and then in hours up to 24.

To cancel the Off Timer, press the **OFF** pad until the display time disappears.

- 7 SLEEP**
Press to set the air conditioner to run for 8 hours before it automatically returns to the previous setting.

When the sleep timer is set, the set temperature will automatically increase 2°F after the second hour then 1°F each hour over the next two hours.

To cancel the sleep mode, press the **MODE** pad or the **SLEEP** pad a second time.

- 8 Remote Control Signal Receiver**

NOTE: When the air conditioner is turned on, it will automatically start in the setting last used.

Remote Control

- To ensure proper operation, aim the remote control at the signal receiver on the air conditioner.
- The remote control signal has a range of up to 21 feet.
- Make sure nothing is between the air conditioner and the remote control that could block the signal.
- Make sure batteries are fresh and installed correctly—see the Care and Cleaning section.

COOL MODE

Remote Control

1. Press **COOL** pad.
2. Press **LOW, MED** or **HIGH** pads to set desired fan speed.
3. Press the **INCREASE + / DECREASE -** pads to set the desired temperature 60°F to 85°F in 1°F increments.

Control Panel

1. Press the **MODE** pad until the **COOL** indicator light is lit and the **LOW, MED** or **HIGH** indicator light is lit for the desired fan speed.
2. Press the **INCREASE + / DECREASE -** pads to set the desired temperature 60°F to 85°F in 1°F increments.

A thermostat is used to maintain the room temperature. The compressor will cycle on and off to keep the room at the set level of comfort. Set the thermostat at a lower number and the indoor air will become cooler.

Set the thermostat at a higher number and the indoor air will become warmer.

NOTE: If the air conditioner is off and is then turned on while set to **COOL**, it will take approximately 3 minutes for the compressor to start and cooling to begin.

Cooling Descriptions

For Normal Cooling—Select the **COOL** mode and **HIGH** or **MED** fan with a middle set temperature.

For Maximum Cooling—Select the **COOL** mode and **HIGH** fan with a lower set temperature.

For Quieter and Nighttime Cooling—Select the **COOL** mode and **LOW** fan with a middle set temperature.

NOTE: If you switch from a **COOL** setting to **OFF** or to a fan setting, wait at least 3 minutes before switching back to a **COOL** setting.

FAN MODE

Use the **FAN** mode to provide air circulation and filtering without cooling. Since fan-only settings do not provide cooling, a temperature setting will not be displayed.

Remote Control

Press **FAN** pad. Press **LOW, MED** or **HIGH** pads to set desired fan speed.

Control Panel

Press the **MODE** pad until the **FAN** indicator light is lit and the **LOW, MED** or **HIGH** indicator light is lit for the desired fan speed.

About the controls on the air conditioner—Heat/Cool Models

Appearance may vary.

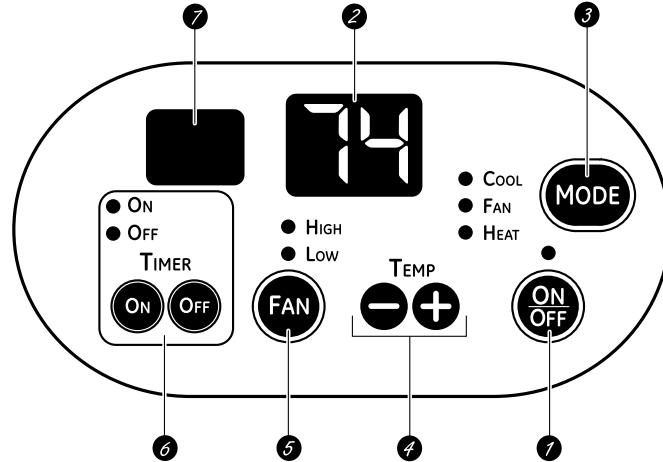

Air Conditioner Controls

Lights beside the touch pads on the air conditioner control panel indicate the selected settings.

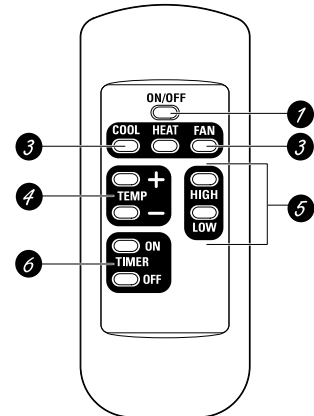

Remote Control



Controls

- 1 ON/OFF**
Turns air conditioner on and off.
- 2 Display**
Displays the temperature setting. Displays hours when setting the timer.
- 3 MODE**
On the air conditioner controls, use to set **COOL**, **HEAT** or **FAN** mode. Indicator lights on the air conditioner controls will show the mode selected.
- 4 TEMP Increase + /Decrease - Pads**
Use to set temperature when in **COOL** or **HEAT** mode.
- 5 FAN Speeds**
Use to set the fan speed at **LOW** or **HIGH**. Indicator lights will show the speed selected.
- 6 TIMER**
ON—When the air conditioner is off, it can be set to automatically turn on in half an hour to 24 hours at its previous setting. Each touch will set the time in half hours up to 10 and then in hours up to 24.

To cancel the On Timer, press the **ON** pad until the display time disappears.
OFF—When the air conditioner is on, it can be set to automatically turn off in half an hour to 24 hours. Each touch will set the time in half hours up to 10 and then in hours up to 24.

To cancel the Off Timer, press the **OFF** pad until the display time disappears.
- 7 Remote Control Signal Receiver**

NOTE: When the air conditioner is turned on, it will automatically start in the setting last used.

Remote Control

- To ensure proper operation, aim the remote control at the signal receiver on the air conditioner.
- The remote control signal has a range of up to 21 feet.
- Make sure nothing is between the air conditioner and the remote control that could block the signal.
- Make sure batteries are fresh and installed correctly—see the Care and Cleaning section.

COOL MODE

Remote Control

1. Press **COOL** pad.
2. Press **LOW** or **HIGH** pads to set desired fan speed.
3. Press the **INCREASE + / DECREASE -** pads to set the desired temperature 60°F to 85°F in 1°F increments.

Control Panel

1. Press the **MODE** pad until the **COOL** indicator light is lit.
2. Press the **FAN** pad until **HIGH** or **LOW** indicator light is lit for desired fan speed.
3. Press the **INCREASE + / DECREASE -** pads to set the desired temperature 60°F to 85°F in 1°F increments.

A thermostat is used to maintain the room temperature. The compressor will cycle on and off to keep the room at the set level of comfort. Set the thermostat at a lower number and the indoor air will become cooler.

Set the thermostat at a higher number and the indoor air will become warmer.

NOTE: If the air conditioner is off and is then turned on while set to **COOL**, it will take approximately 3 minutes for the compressor to start and cooling to begin.

Cooling Descriptions

For Normal Cooling—Select the **COOL** mode and **HIGH** fan with a middle set temperature.

For Maximum Cooling—Select the **COOL** mode and **HIGH** fan with a lower set temperature.

For Quieter and Nighttime Cooling—Select the **COOL** mode and **LOW** fan with a middle set temperature.

NOTE: There will be a 3-minute delay between setting changes such as **COOL** to **OFF** and back to **COOL**.

HEAT MODE

Remote Control

1. Press **HEAT** pad.
2. Press **LOW** or **HIGH** pads to set desired fan speed.
3. Press the **INCREASE + / DECREASE -** pads to set the desired temperature 60°F to 85°F in 1°F increments.

Control Panel

1. Press the **MODE** pad until the **HEAT** indicator light is lit.
2. Press the **FAN** pad until **HIGH** or **LOW** indicator light is lit for desired fan speed.
3. Press the **INCREASE + / DECREASE -** pads to set the desired temperature 60°F to 85°F in 1°F increments.

A thermostat is used to maintain the room temperature. The compressor will cycle on and off to keep the room at the set level of comfort. Set the thermostat at a higher number and the indoor air will become warmer.

Set the thermostat at a lower number and the indoor air will become cooler.

NOTE: If the air conditioner is off and is then turned on while set to **HEAT**, it will take approximately 3 minutes for the compressor to start and heating to begin.

Heating Descriptions

For Normal Heating—Select the **Heat** mode and **HIGH** fan with a middle set temperature.

For Maximum Heating—Select the **HEAT** mode and **HIGH** fan with a higher set temperature.

For Quieter and Nighttime Heating—Select the **HEAT** mode and **LOW** fan with a middle set temperature.

FAN

Use the **FAN** to provide air circulation and filtering without cooling or heating. Since fan only settings do not provide cooling or heating, a temperature setting will not be displayed.

Remote Control

Press **FAN** pad. Press **LOW** or **HIGH** pads to set desired fan speed.

Control Panel

Press the **MODE** pad until the **FAN** indicator light is lit and the **LOW** or **HIGH** indicator light is lit for the desired fan speed.

About the controls on the air conditioner

Vent Control

The vent control is located behind the front grille on the right side of the air discharge area. When **CLOSED**, only the air inside the room will be circulated and conditioned. When **OPEN**, the vent allows outdoor fresh air exchange.

To open or close the vent:

1. Remove the front grille.
2. Remove the vent card screw.
3. Remove vent card, turn it over and replace it by locating rear hole in card over locating pin inside air discharge and reattaching screw at front.

The unit leaves the factory set at the CLOSE position.

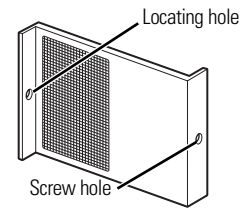

OPEN position
(Mesh end toward back)

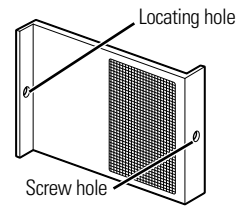

CLOSE position
(Mesh end toward front)

Air Direction

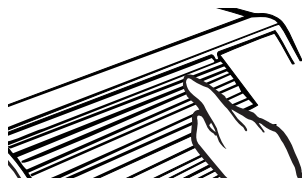

Horizontal louvers on the front grille let you control the air direction up and down.

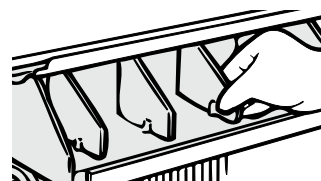

Remove the front grille to adjust the vertical louvers side-to-side to direct the air left or right.

Auxiliary Controls – Dip Switches (location varies by model)

The auxiliary dip switch controls are located behind the room cabinet—as shown in this figure.

The owner is responsible for checking switches and ensuring they are in the desired position.

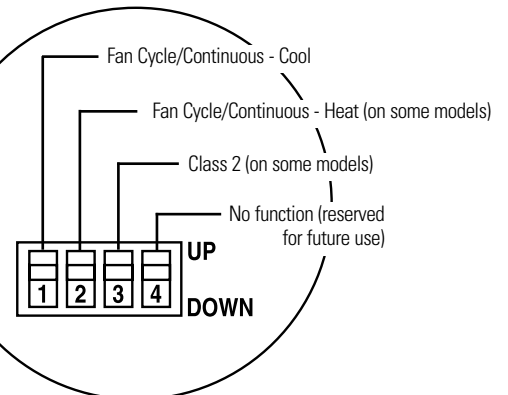
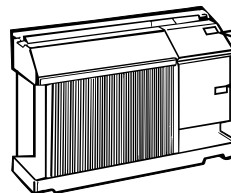

Fan Cycle/Continuous - Cool

When this switch is enabled (**UP**), it allows the indoor fan to cycle on/off with the compressor. When this switch is disabled (**DOWN**), it allows the indoor fan to run continuously. The default setting is down (continuous).

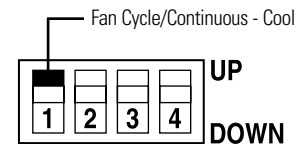

Fan Cycle/Continuous - Heat (on some models)

When this switch is enabled (**UP**), it allows the indoor fan to cycle on/off with the heater operation. When this switch is disabled (**DOWN**), it allows the indoor fan to run continuously. The default setting is **UP** (cyclic).

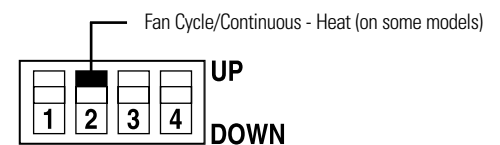

Class 2 - Remote Thermostat (on some models)

When this switch is enabled (**UP**), it allows the unit to operate with a Class 2 Remote Control Wall Thermostat. The unit controls are disabled. The default setting is down (disabled).

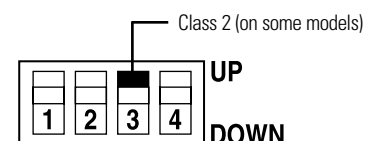

Terminal Connections Remote Thermostat - Class 2 (on some models)

The controls are located under a plastic cover behind the front grille.

- 1 Remove the front grille. See the Front Grille section of Care and Cleaning.
- 2 Remove the screws securing the plastic cover over the wiring connections. Set aside screws and plastic cover.
- 3 To make wiring connections, insert the wires into the bottom of the terminals and tighten screws securely.
- 4 After all desired connections have been made, replace the plastic cover and front grille.

The owner is responsible for making all connections and setting the appropriate dip switches.

When connected, the unit will be controlled by a remote thermostat.

NOTE: The number 3 dip switch must be in the enabled (**UP**) position to activate the remote thermostat. (See the installation instructions supplied with the remote thermostat.)

IMPORTANT:

The thermostat connections provide 24 V AC only.

If using a digital/electronic wall thermostat, ensure it is compatible with 24 VAC signal. See the Installation Instructions for the wall thermostat.

NOTICE:

Damage to a wall thermostat or to the electronics can result from improper connections. Special care must be used in connecting the wires. No line voltage connections should be made to any circuit. Isolate all wires in building from line voltage.

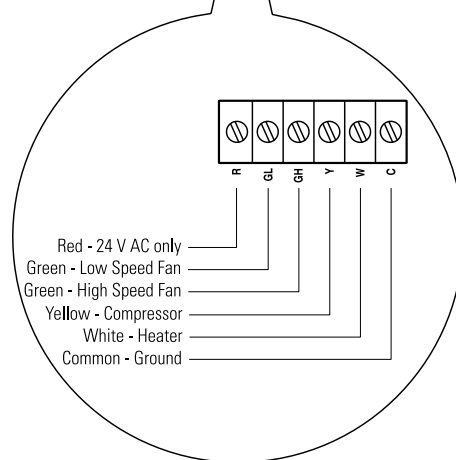
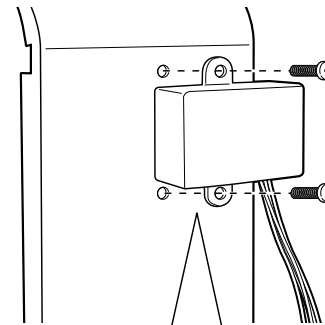
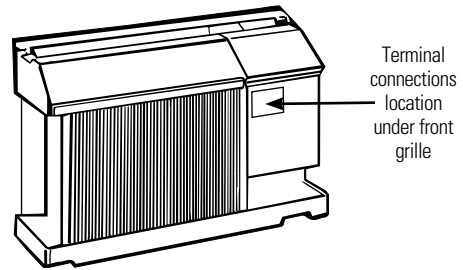

Care and cleaning of the air conditioner.

Grille and Case

Turn the air conditioner off and remove the plug from the wall outlet before cleaning.

To clean, use water and a mild detergent. Do not use bleach or abrasives.

Outdoor Coils

The coils on the outdoor side of the air conditioner should be checked regularly. If they are clogged with dirt or soot they may be professionally steam cleaned, a service available through your GE service outlet.

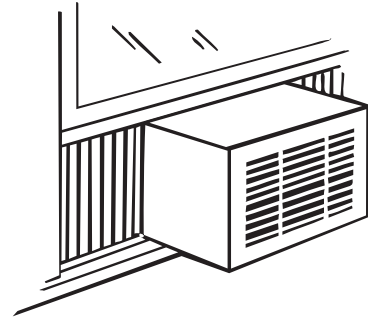

Front Grille

The front grille can be removed for more thorough cleaning and to locate the model and serial numbers on the front of the base pan.

3. Pull the grille out from the bottom and lift up from the tabs on the top of the case.

To remove:

1. Pull the filter out.
2. Remove the two grille screws.

On some models

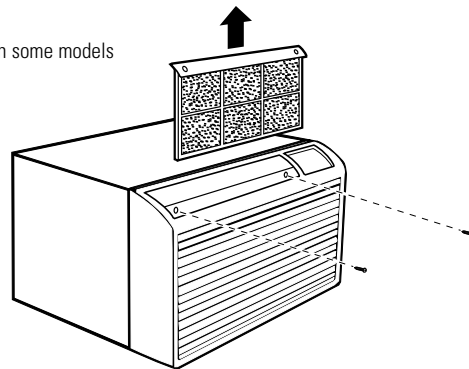

On some models

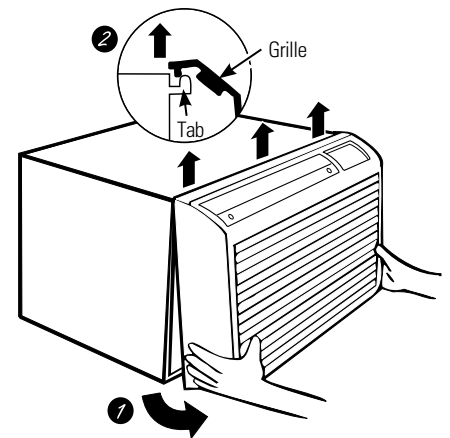
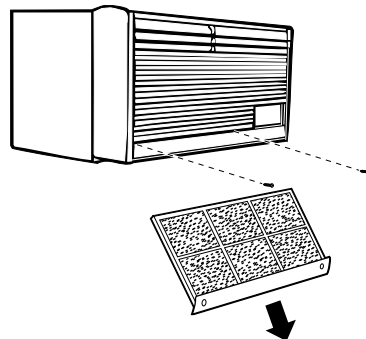

To replace:

Hook the tabs on the front grille even with the tabs on the case and snap into place.

Replace the screws and filter.

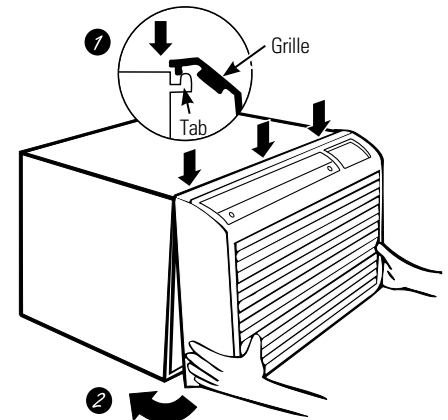

To maintain optimum performance, clean the filter at least every 30 days.

Air Filter

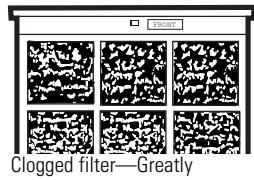
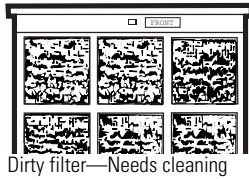

Turn the air conditioner off before cleaning.

The most important thing you can do to maintain the air conditioner is to clean the filter at least every 30 days. A clogged filter reduces cooling, heating and air flow.

Keeping the air filter clean will:

- Decrease cost of operation.
- Save energy.
- Prevent clogged heat exchanger coils.
- Reduce the risk of premature component failure.

To clean the air filters:

- Vacuum off the heavy soil.
- Run water through the filters.
- Dry thoroughly before replacing.

To remove the air filter, on some models:

Carefully pull the tab forward, up and out.

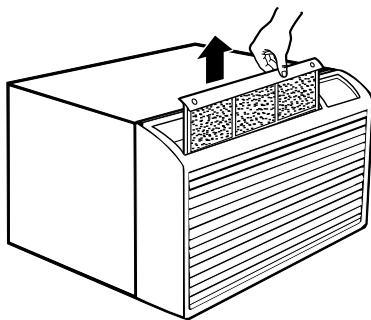

To remove the air filter, on other models:

Pull it down.

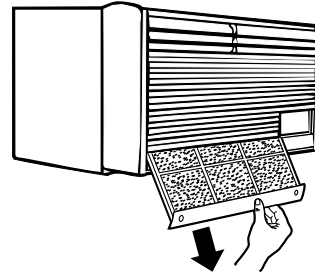

To replace the air filter:

Replace the clean filter by pushing it back into place.

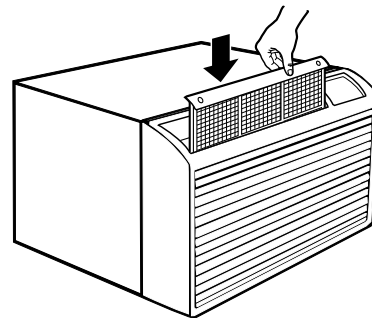

NOTICE: Do not operate the air conditioner without the filter in place. If a filter becomes torn or damaged it should be replaced immediately.

Operating without the filter in place or with a damaged filter will allow dirt and dust to reach the indoor coil and reduce the cooling, heating, airflow and efficiency of the unit.

Replacement filters are available from your salesperson, GE dealer, GE Service and Parts Center or authorized Customer Care® servicers.

How to Insert the Batteries in the Remote Control

- 1 Remove the battery cover by sliding it according to the arrow direction.
- 2 Insert new batteries making sure that the (+) and (-) of battery are installed correctly.
- 3 Reattach the cover by sliding it back into position.

NOTES:

- Use 2 AAA (1.5 volt) batteries. Do not use rechargeable batteries.
- Remove the batteries from the remote control if the system is not going to be used for a long time.

Installation Instructions

Air Conditioner

? Questions? Call 800.GE.CARES (800.432.2737) or Visit our Website at: GEAppliances.com



BEFORE YOU BEGIN

Read these instructions completely and carefully.

- **IMPORTANT** – Save these instructions for local inspector's use.
- **IMPORTANT** – Observe all governing codes and ordinances.
- **Note to Installer** – Be sure to leave these instructions with the Consumer.
- **Note to Consumer** – Keep these instructions for future reference.
- **Skill level** – Installation of this appliance requires basic mechanical skills.
- **Completion time** – Approximately 1 hour
- We recommend that two people install this product.
- Proper installation is the responsibility of the installer.
- Product failure due to improper installation is not covered under the Warranty.

Air conditioner break-in period

NOTE – As with any mechanical device with moving parts, this unit will have a wear-in period. AFTER INSTALLATION, this unit should be operated for 48 hours to achieve optimum efficiency.



ELECTRICAL REQUIREMENTS

⚠ WARNING! Risk of electric shock. Can cause injury or death. This appliance must be properly grounded. Where a 2-prong wall outlet is encountered, it is your responsibility and obligation to have it replaced with a properly grounded 3-prong outlet.



Some models require a 115/120-volt a.c., 60-Hz grounded outlet protected with a 15-amp time delay fuse or circuit breaker.

The 3-prong grounding plug minimizes the possibility of electric shock hazard. If the wall outlet you plan to use is only a 2-prong outlet, it is your responsibility to have it replaced with a properly grounded 3-prong wall outlet.

Do not, under any circumstances, cut or remove the third (ground) prong from the power cord.



ELECTRICAL REQUIREMENTS (cont.)



Do not change the plug on the power cord of this air conditioner.



Aluminum house wiring may present special problems—consult a qualified electrician.

Some models require 230/208-volt a.c., protected with a time delay fuse or circuit breaker. These models should be installed on their own single branch circuit for best performance and to prevent overloading house or apartment wiring circuits, which could cause a possible fire hazard from overheating wires.

IMPORTANT!

GE strongly recommends the removal of the old wall case and the installation of a new GE Wall Case. If you decide to keep the existing wall case, you may need a kit to ensure proper performance. If you DO NOT use a kit, you run the risk of poor performance or product failure. This is not covered under the terms of the GE warranty.

J-MODEL QUALIFYING QUESTIONS

J-model air conditioners may fit in existing wall cases. However, they often need a kit to properly adapt the case to the GE air conditioner. Answer these questions and see the chart on the next page for the proper kit.

- A** What brand air conditioner will you be replacing?
- B** What are the dimensions of the wall case currently in use?
- C** What is the model number of the chassis currently in use? What is the model (or Type) number of the wall case currently in use?

Frequently, the J-model adapter kit will apply to another brand model "series" or specific vintage. In these cases, you need the chassis model number and/or the wall case or "type" number to confirm the use of the correct adapter kit.

- D** What type of outdoor grille is used with the current wall case?

There may be an architectural grille attached to a wall case to enhance the exterior appearance of the building. Custom grilles may be used with J-model wall cases provided a J-model adapter kit is also used to ensure proper airflow.

Installation Instructions

Read these instructions completely and carefully.

Power cord may include a current interrupter device. A test and reset button is provided on the plug case. The device should be tested on a periodic basis by first pressing the **TEST** button and then the **RESET** button.

If the **TEST** button does not trip or if the **RESET** button will not stay engaged, discontinue use of the air conditioner and contact a qualified service technician.

TOOLS YOU MAY NEED



Phillips-head screwdriver

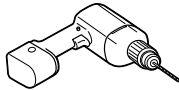

Drill

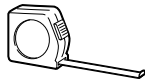

Ruler or Tape Measure

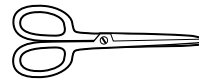

Scissors or knife

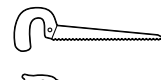

Hand or Saber Saw

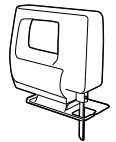

Adjustable Wrench

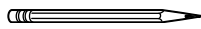

Pencil



Level

GE KIT NUMBERS

USE GE KIT NUMBER:	FOR:	DESCRIPTION:
RAB46A, 47A & 48A	Use these kits for all GE models and other brands not listed	Standard wall case for "J" model chassis. RAG13 stamped aluminum exterior grille included. Remove the existing case and replace.
RAK65A1	All GE Models	Kit for window installation.
RAK56A100	GE RAB13, 14 & 15 (ACLB & RCL Chassis)	Fits all GE wall cases 26"W x 18"H x 24"D.
RAK1072	Hotpoint ACXB10 & 11 (ACTB Chassis)	Adapts an older Hotpoint wall case to a "J" model chassis. Fits Hotpoint wall cases 25¾"W x 16⅞"H x 18⅝"D.
RAK1082	Whirlpool Type 23W Wall Case	Adapts Whirlpool wall case to a "J" model chassis. Fits Whirlpool wall cases 25⅞"W x 16½"H x 23⅛"D.
RAK1102	GE RAB30 ("F" models)	Adapts GE wall case to a "J" model chassis. Fits the RAB 30 wall case 26"W x 18"H x 24"D.
RAK123A64	Fedders Wall Case "A"	Adapts Fedders wall case to a "J" model chassis. Fits Fedders wall cases 27"W x 16¾"H x 16¾"D.
RAK126	Westinghouse Wall Case (Type 2626D73H01)	Adapts Westinghouse wall case to a "J" model chassis. Fits Westinghouse wall cases 25⅞"W x 15⅞"H x 16"D.
RAB46, 47 & 48	Use these kits for all other brands not listed.	Standard wall case for "J" model chassis. RAG13 stamped aluminum exterior grille included. Remove the existing case and replace.
RAK690	RAB36, 37, 38, 46, 47 or 48 (J-Chassis)	If you attach a custom architectural outdoor grille, use this kit to ensure proper airflow.
RAG13	RAB36, 37, 38, 46, 47 or 48 (J-Chassis)	Standard aluminum exterior grille (included with RAB46, 47 and 48 wall cases).
RAG14E	RAB36, 37, 38, 46, 47 or 48 (J-Chassis)	Architectural louvered exterior grille.

Installation Instructions

INSTALLING A J-MODEL IN AN EXISTING WALL CASE

Read these instructions completely and carefully.

1 REMOVE LOCKING PLATE ON FRONT LEFT SIDE

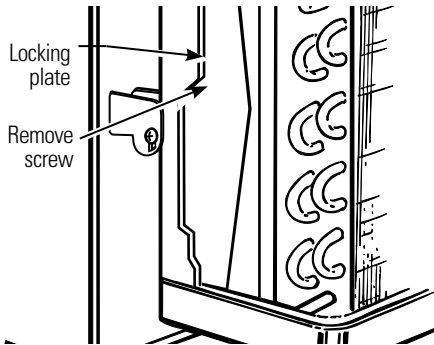

4 REINSTALL LOCKING PLATE WITH TAB BEHIND WALL CASE FLANGE. TIGHTEN SCREW

5 ATTACH POWER CORD TO BASE PAN WITH CLAMP

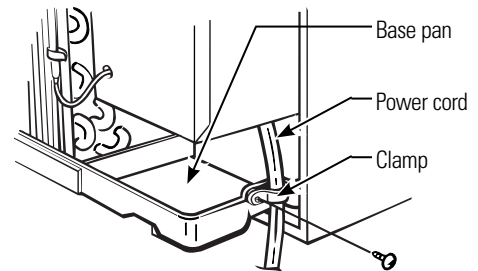

2 REMOVE ALL SHIPPING PADS (IF PRESENT) INSIDE AIR CONDITIONER NEXT TO COMPRESSOR

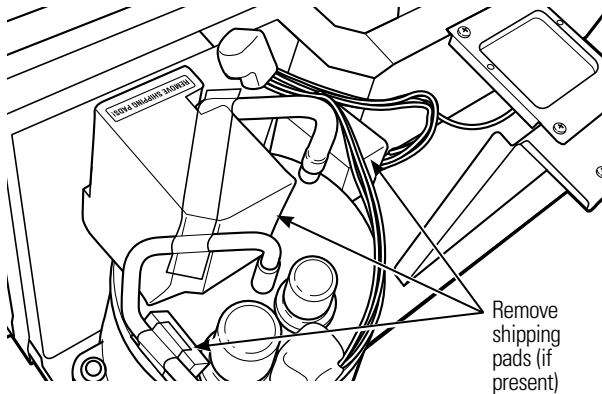

6 ATTACH FRONT GRILLE

An opening for the power cord is on the bottom of the front grille.

3 CAREFULLY SLIDE AIR CONDITIONER BACK INTO CASE

Make sure that the tubing on the unit does not touch the wall case and that the case installation is secure.

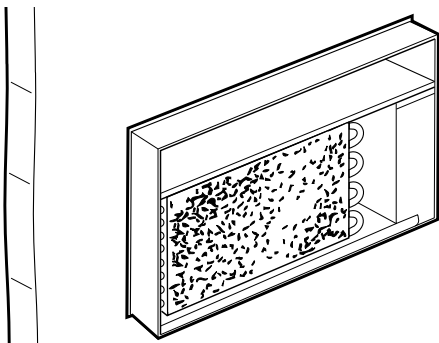

Installation Instructions

INSTALLING THROUGH THE WALL

Read these instructions completely and carefully.

1 PREPARE OPENING IN WALL

Make certain a wall receptacle is available close to the hole location or make arrangements to install a receptacle.

The cord length for the 115-volt models is 72" to the right and 47" to the left.

For the 230/208-volt models the cord length is 65" to the right and 39" to the left.

2 SUPPORT REQUIREMENTS FOR AIR CONDITIONER

The air conditioner wall case may be installed with 1/4" min. extension out from the inside wall or with 1/4" min. extension out from the outside wall.

The finished sides of the opening should be structural wall members.

Lintel – Use a lintel in brick veneer and brick and block types of wall to support the bricks or blocks above the opening. Do not allow the wall case to be used in lieu of a lintel.

Flashing – Install flashing (drip rail) as shown to prevent water from dripping inside the wall and down the outside of the building.

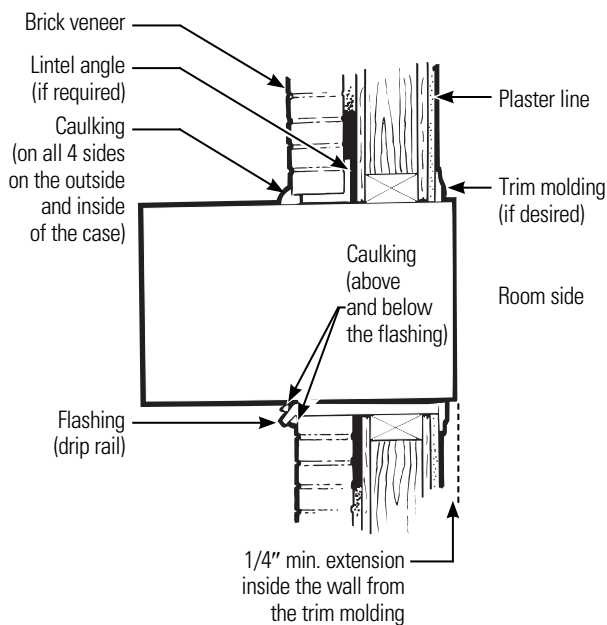

3 SUPPORT REQUIREMENTS FOR AIR CONDITIONER

Mortar between the case and the brick wall around the case may be undercut at about 45° for improved caulking.

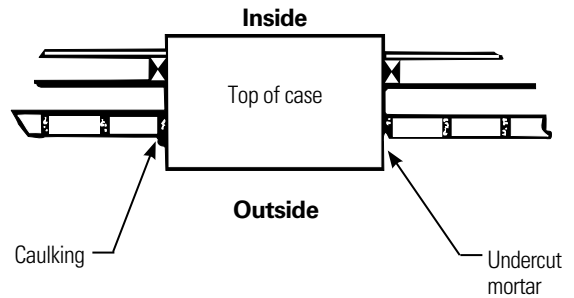

Installation Instructions

WINDOW INSTALLATION—OPTIONAL

▲ WARNING! Risk of injury. Installation must comply with these guidelines.

Requires optional accessory kits RAK65A1 and Wall Sleeve RAB46A, 47A or 48A

Read these instructions completely and carefully.

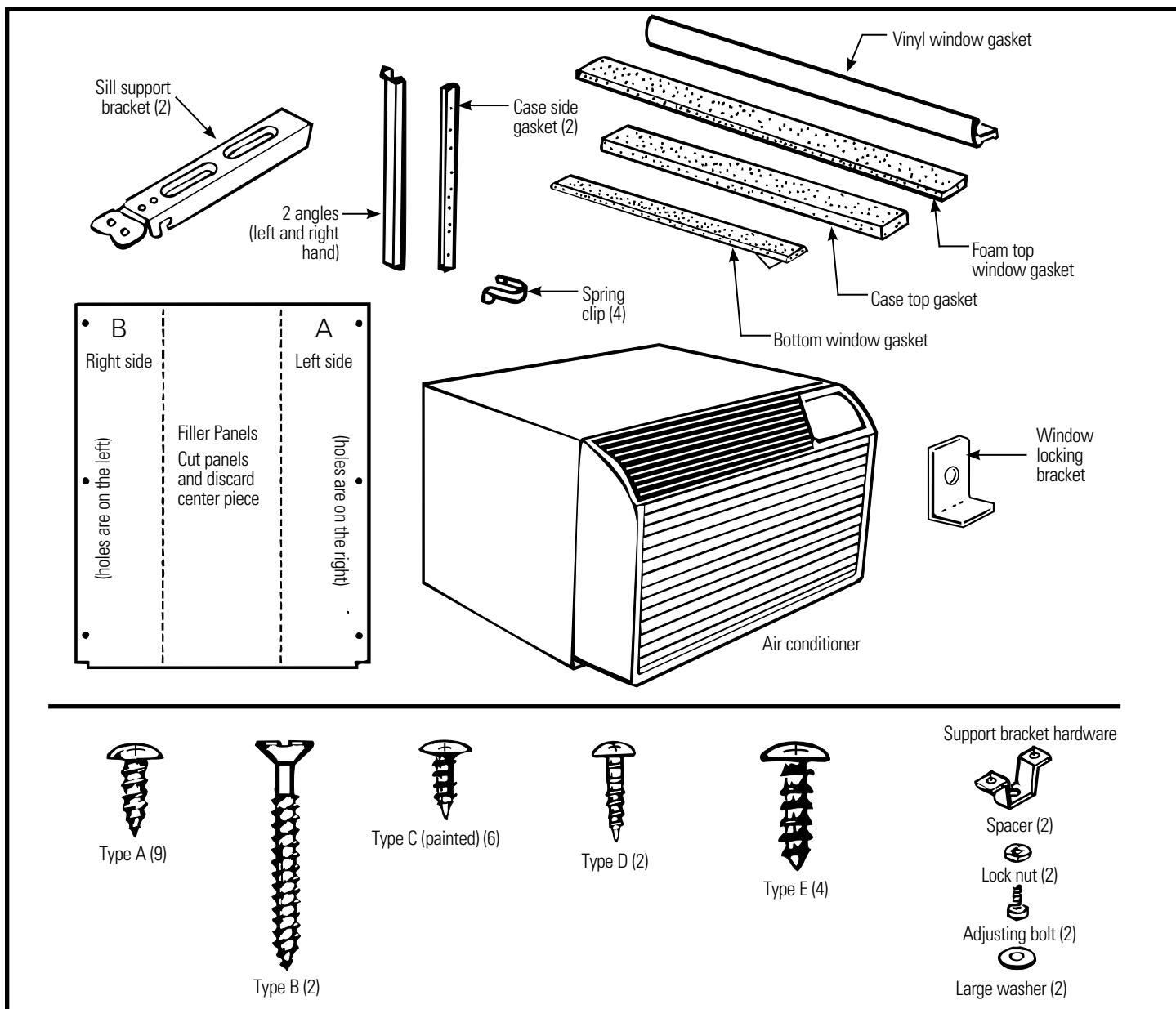

1 WINDOW REQUIREMENTS

- These instructions are for a standard double-hung window. You will need to modify them for other types of windows.
- The air conditioner can be installed without the accordion panels if needed to fit in a narrow window. See the window opening dimensions to the right.
- All supporting parts must be secured to firm wood, masonry or metal.
- The electrical outlet must be within reach of the power cord.

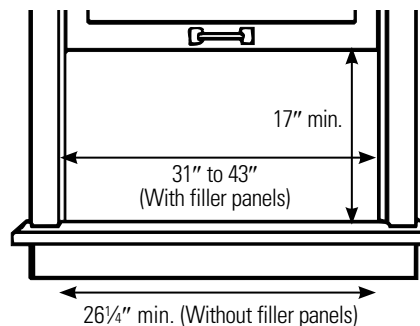

Window opening dimensions are for a standard double-hung window.

Installation Instructions

2 STORM WINDOW REQUIREMENTS

A storm window frame will not allow the air conditioner to tilt towards the outside and will keep it from draining properly. To adjust for this, attach a piece of wood to the stool.

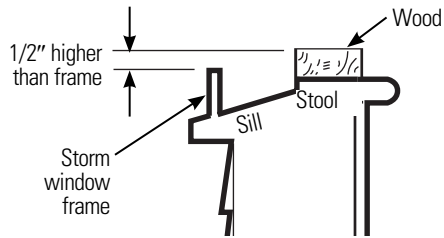

WOOD PIECES

WIDTH: 2"

LENGTH: Long enough to fit inside the window frame.

THICKNESS: To determine the thickness, place a piece of wood on the stool to make it 1/2" higher than the top of the storm window frame.

Attach securely with nails or screws provided by the installer.

3 REMOVE AIR CONDITIONER FROM CASE

A Remove the front grille. See the Care and Cleaning section.

B Find the locking plate located on the front left side.

C Remove the screw and the locking plate to unlock the air conditioner.

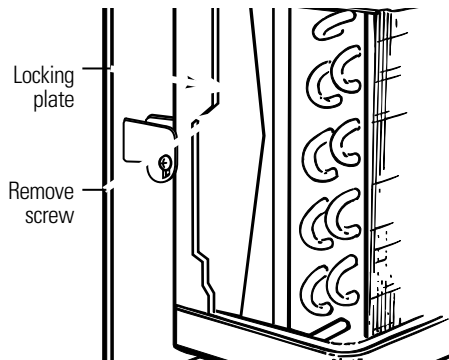

D Remove and discard the shipping screw on the back of the air conditioner to allow removal of the air conditioner from the case.

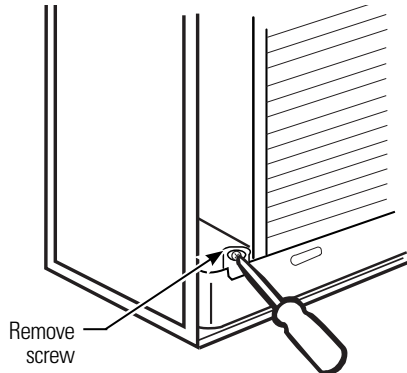

E Pull the bottom corners of the air conditioner and slide it out of the case.

F Remove all shipping pads (if present) inside the air conditioner next to the compressor.

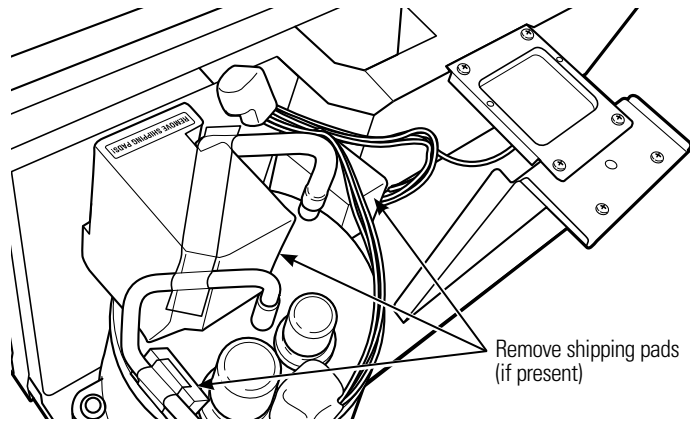

G Remove the rear grille that is taped to the back of the case. Remove the packet of screws taped to the back of the grille. While holding the grille at a 45° angle, insert it into the clips at the top of the case and push the bottom in. Keep slight upward pressure on the grille until it fits flush with the bottom of the case.

If attaching the grille from the outside of the case, use the 2 long screws.

If attaching the grille from the inside of the case, use the 2 short screws.

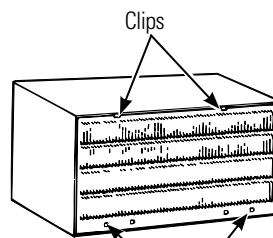

Insert the 2 long screws on the outside

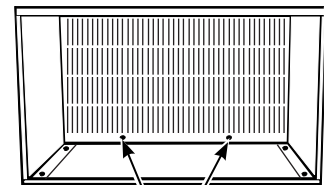

Insert the 2 short screws on the inside

Installation Instructions

WINDOW INSTALLATION—OPTIONAL (cont.)

4 PREPARE WINDOW

A Mark the centerline of the stool. Measure from the centerline $13\frac{3}{8}$ " on both sides for the panel cuts.

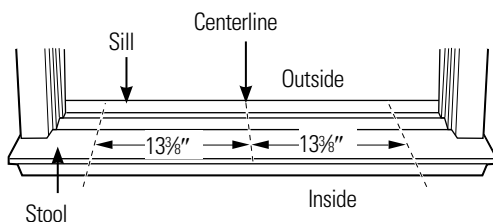

B Measure $12\frac{3}{8}$ " from the centerline on both sides for the sill support brackets.

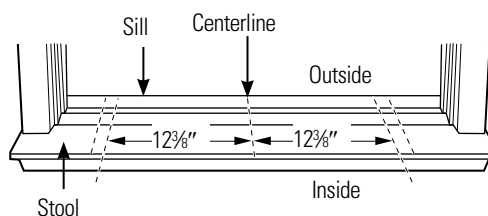

5 INSTALL SILL SUPPORTS

A Assemble the sill supports. Do not fully tighten the spacer mounting screws at this time.

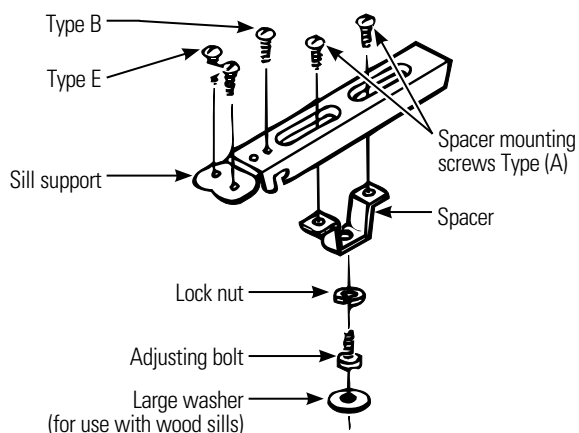

C Turn the bolts and tighten the lock nuts to make the sill supports level or tilt down $1/8$ " to the outside. Line up the "V" notch with $12\frac{3}{8}$ " marks. Drill pilot holes and attach the sill supports.

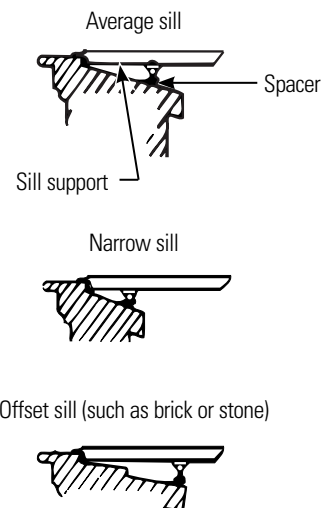

B Before attaching the sill supports, place them on the window stool. Select the spacer position that will place the spacer near the outermost point on the sill. Tighten the spacer mounting screws.

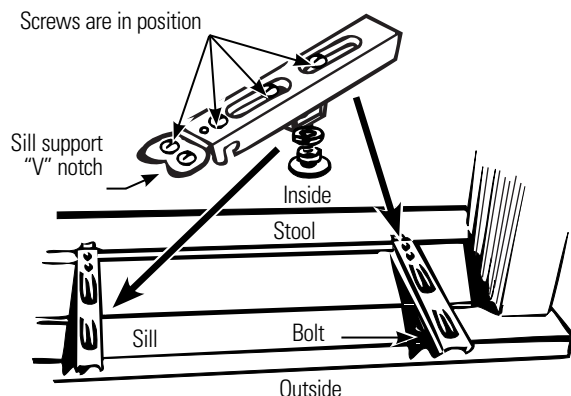

NOTES:

- On narrow sills, there may not be enough room to use the lock nut.
- A deep offset sill may require a longer adjusting bolt than the standard hex-head bolt provided.
- On wood sills use the large washer between the bolt head and the sill. This prevents the bolt from digging into the wood.

Installation Instructions

6 MEASURE, CUT AND INSTALL FILLER PANELS

A Measure from the edge of the panel marks (see Prepare the Window) to the inside of the window track on each side (A and B).

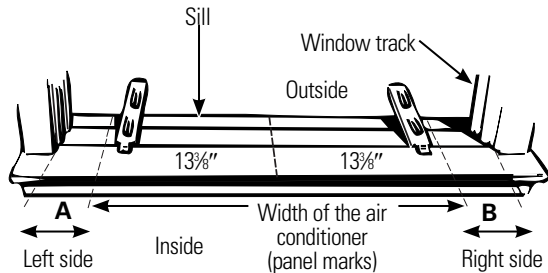

B Mark the **A** and **B** measurements on each side of the filler panel board. Cut the panels and discard the center piece. Note position of the notches.

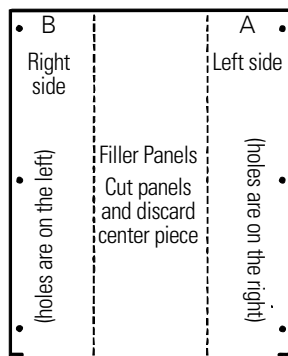

C Put together the panel assemblies. Remove the paper backing from the case-side gasket and attach it to the angle. Push a pencil point through the gaskets to locate the holes in the angles.

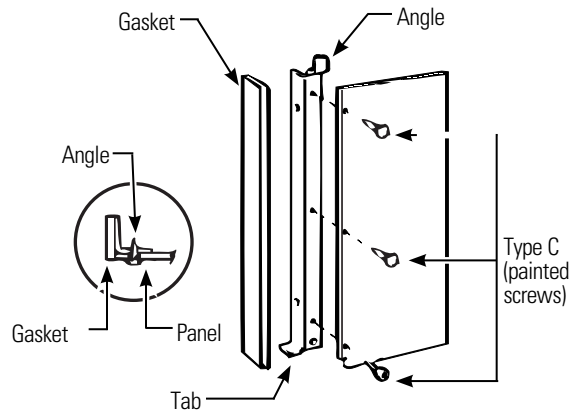

D Install the panels in the window. Place the spring clips 3" from the top and the bottom. Squeeze and push the clips to fit in the window track and the tab into the sill support.

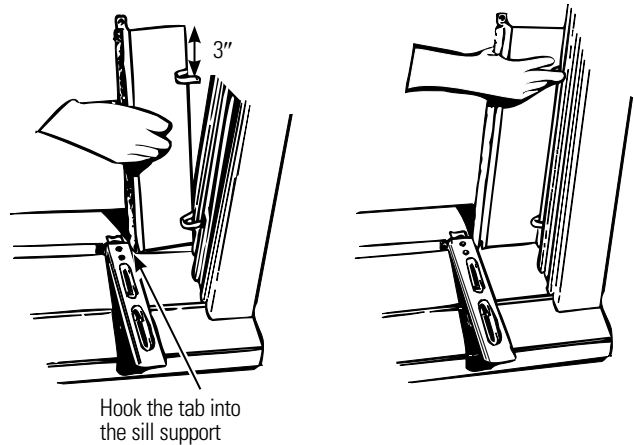

Installation Instructions

WINDOW INSTALLATION—OPTIONAL (cont.)

7 INSTALL CASE IN WINDOW

- A** Peel off the backing from the bottom window gasket.
- B** Place the gasket on the stool and over the brackets, even with the rear edge, sticky side down.

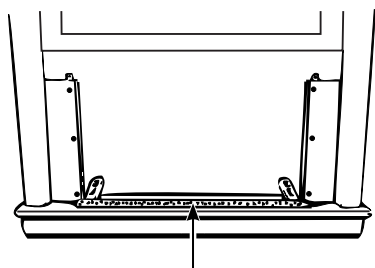

Bottom window gasket

- C** Carefully slide the empty case into the window until the holes in the case line up with the holes in the panel angles.

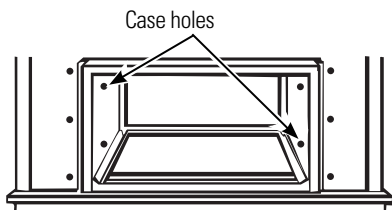

Case holes

NOTES:

- The case should have a 1/8" minimum tilt toward the outside.
 - Be sure the seal gasket and panel gaskets remain in position and do not roll with the case.
- D** Lower the window so it fits behind the panel tabs. Insert the 4 type A screws through the holes in the case and into the panel angles, 2 on each side.

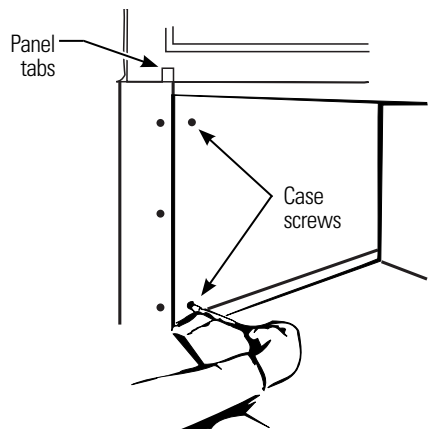

Panel tabs

Case screws

- E** With the window closed, mark where the window sash meets the case.
- F** Peel off the backing from the case top gasket.
- G** Hold on to the case, open the window and place the gasket along the mark on the case.

Put the gasket on top of the case where the window will close.

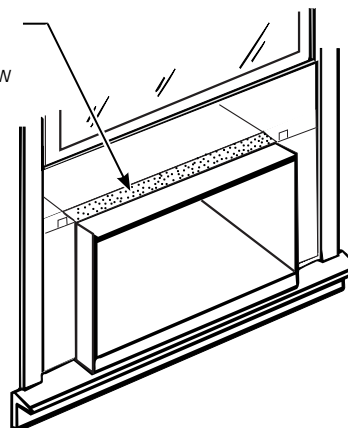

- H** Place the vinyl window gasket over the case top gasket. Insert the panel tabs through the slits in the gasket. Cut the gasket on each side to the width of the window.

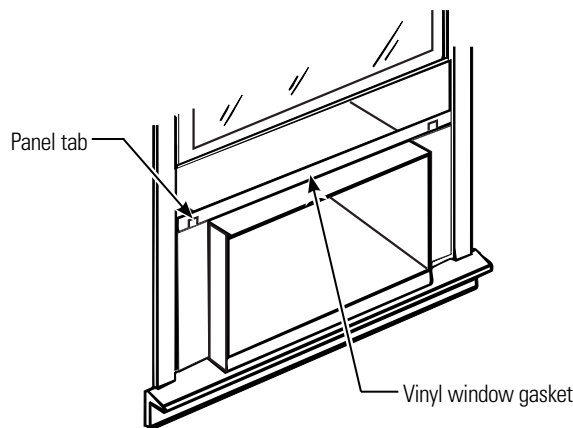

Panel tab

Vinyl window gasket

- I** Close the window tightly on the vinyl gasket. Bend the gasket forward to expose the panel tabs. Drill pilot holes into the window sash.

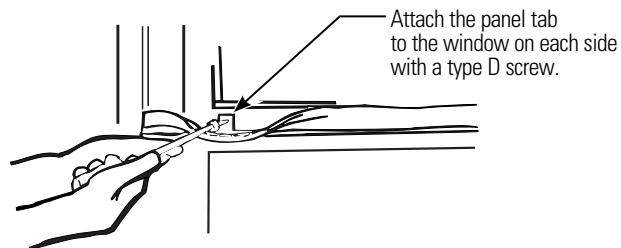

Attach the panel tab to the window on each side with a type D screw.

Installation Instructions

8 INSTALL WINDOW GASKET AND LOCKING BRACKET

- A** Cut the foam top window gasket to the window width.
- B** Stuff the foam between the glass and the window to prevent air and insects from getting into the room.



- C** Attach the window locking bracket with 1 type E screw.

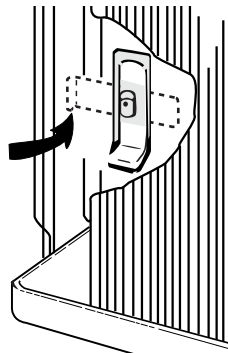

9 REPLACE AIR CONDITIONER IN CASE

- A** Carefully slide the air conditioner back into the case.

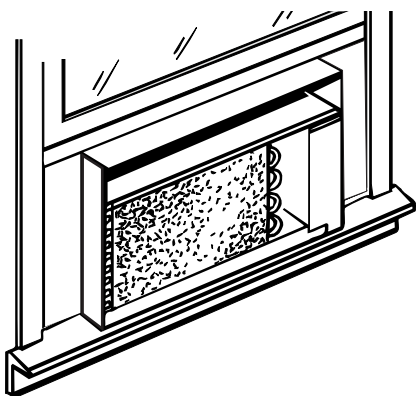

- B** Attach the power cord to the base pan with the clamp.

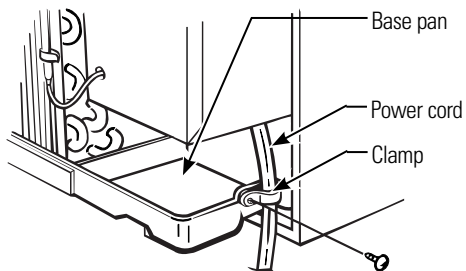

- C** Reinstall the locking plate with the tab behind the wall case flange. Tighten the screw.

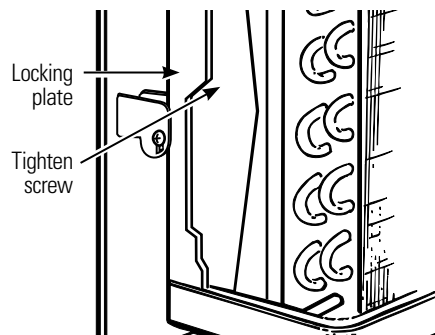

- D** Reattach the front grille. An opening for the power cord is on the bottom of the front grille.
- E** Fill holes and cracks with caulking provided by the installer.

Before you call for service...

Troubleshooting Tips: Save time and money! Review the chart below first and you may not need to call for service.

Problem	Possible Causes	What To Do
Air conditioner does not start	The air conditioner is unplugged.	• Make sure the air conditioner plug is pushed completely into the outlet.
	The fuse is blown/circuit breaker is tripped.	• Check the house fuse/circuit breaker box and replace the fuse or reset the breaker.
	Power failure.	• If power failure occurs, turn the air conditioner OFF . When power is restored, wait 3 minutes to restart the air conditioner to prevent tripping of the compressor overload.
	The current interrupter device is tripped.	• Press the RESET button located on the power cord plug. • If the RESET button will not stay engaged, discontinue use of the air conditioner and contact a qualified service technician.
Air conditioner does not cool or heat (some models) as it should	Airflow is restricted.	• Make sure there are no curtains, blinds or furniture blocking the front of the air conditioner.
	The temp control may not be set correctly.	• In COOL mode or HEAT mode (some models), press the DECREASE – pad.
	The air filter is dirty.	• Clean the filter at least every 30 days. See the <i>Operating Instructions</i> section.
	The room may have been hot.	• When the air conditioner is first turned on, you need to allow time for the room to cool down.
	Cold air is escaping.	• Check for open furnace registers and cold air returns. • Make sure the air conditioner's vent is in the closed position.
Air conditioner freezing up	Cooling coils have iced up.	• See " Air conditioner freezing up " below.
Air conditioner freezing up	Ice blocks the airflow and stops the air conditioner from cooling the room.	• Set the controls at HIGH FAN or HIGH COOL and set the thermostat to a higher temperature to allow the ice to melt.
The remote control is not working	The batteries are inserted incorrectly.	• Check the position of the batteries. They should be inserted correctly.
	The batteries may be dead.	• Replace the batteries.
Water drips outside	Hot, humid weather.	• This is normal.
Water drips indoors	The air conditioner is not tilted to the outside.	• For proper water disposal, make sure the air conditioner slants slightly from the case front to the rear.
Water collects in base pan	Moisture removed from air and drains into base pan.	• This is normal for a short period in areas with little humidity; normal for a longer period in very humid areas.

Normal Operating Sounds

- You may hear a pinging noise caused by water being picked up and thrown against the condenser on rainy days or when the humidity is high. This design feature helps remove moisture and improve efficiency.
- You may hear the thermostat click when the compressor cycles on and off.
- Water will collect in the base pan during high humidity or on rainy days. The water may overflow and drip from the outdoor side of the unit.
- The fan may run even when the compressor does not.

Air Conditioner Warranty.



All warranty service provided by our Factory Service Centers, or an authorized Customer Care® technician. To schedule service, on-line visit us at GEAppliances.com, or call 800.GE.CARES (800.432.2737). For service in Canada, contact Gordon Williams Corp. at 1.888.209.0999. Please have serial number and model number available when calling for service.

Staple your receipt here. Proof of the original purchase date is needed to obtain service under the warranty.

For The Period Of:	GE Will Replace:
One Year From the date of the original purchase	Any part of the air conditioner which fails due to a defect in materials or workmanship. During this limited one-year warranty , GE will also provide, free of charge , all labor and related service to replace the defective part.
Five Years From the date of the original purchase	Any part of the sealed refrigerating system (the compressor, condenser, evaporator and all connecting tubing) which fails due to a defect in materials or workmanship. During this four-year limited additional warranty , GE will also provide, free of charge , all labor and related service to replace the defective part.

What GE Will Not Cover:

- Service trips to your home to teach you how to use the product.
- Improper installation, delivery or maintenance. If you have an installation problem, or if the air conditioner is of improper cooling capacity for the intended use, contact your dealer or installer. You are responsible for providing adequate electrical connecting facilities.
- Failure of the product resulting from modifications to the product or due to unreasonable use including failure to provide reasonable and necessary maintenance.
- In commercial locations labor necessary to move the unit to a location where it is accessible for service by an individual technician.
- Replacement of house fuses or resetting of circuit breakers.
- Failure due to corrosion on models not corrosion-protected.
- Damage to the product caused by improper power supply voltage, accident, fire, floods or acts of God.
- Incidental or consequential damage caused by possible defects with this air conditioner.
- Damage caused after delivery.
- Product not accessible to provide required service.

EXCLUSION OF IMPLIED WARRANTIES—Your sole and exclusive remedy is product repair as provided in this Limited Warranty. Any implied warranties, including the implied warranties of merchantability or fitness for a particular purpose, are limited to one year or the shortest period allowed by law.

This warranty is extended to the original purchaser and any succeeding owner for products purchased for home use within the USA and Canada. If the product is located in an area where service by a GE Authorized Servicer is not available, you may be responsible for a trip charge or you may be required to bring the product to an Authorized GE Service location for service. In Alaska, the warranty excludes the cost of shipping or service calls to your home.

Some states do not allow the exclusion or limitation of incidental or consequential damages. This warranty gives you specific legal rights, and you may also have other rights which vary from state to state. To know what your legal rights are, consult your local or state consumer affairs office or your state's Attorney General.

Warrantor: General Electric Company. Louisville, KY 40225

Safety Instructions
Operating Instructions
Care and Cleaning
Installation Instructions
Troubleshooting Tips
Consumer Support

Consumer Support.



GE Appliances Website

GEAppliances.com

Have a question or need assistance with your appliance? Try the GE Appliances Website 24 hours a day, any day of the year! For greater convenience and faster service, you can now download Owner's Manuals, order parts or even schedule service on-line.



Schedule Service

GEAppliances.com

Expert GE repair service is only one step away from your door. Get on-line and schedule your service at your convenience any day of the year! Or call 800.GE.CARES (800.432.2737) during normal business hours.



Real Life Design Studio

GEAppliances.com

GE supports the Universal Design concept—products, services and environments that can be used by people of all ages, sizes and capabilities. We recognize the need to design for a wide range of physical and mental abilities and impairments. For details of GE's Universal Design applications, including kitchen design ideas for people with disabilities, check out our Website today. For the hearing impaired, please call 800.TDD.GEAC (800.833.4322).



Extended Warranties

GEAppliances.com

Purchase a GE extended warranty and learn about special discounts that are available while your warranty is still in effect. You can purchase it on-line anytime, or call 800.626.2224 during normal business hours. GE Consumer Home Services will still be there after your warranty expires.

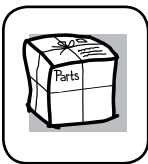

Parts and Accessories

GEAppliances.com

Individuals qualified to service their own appliances can have parts or accessories sent directly to their homes (VISA, MasterCard and Discover cards are accepted). Order on-line today, 24 hours every day or by phone at 800.626.2002 during normal business hours.

Instructions contained in this manual cover procedures to be performed by any user. Other servicing generally should be referred to qualified service personnel. Caution must be exercised, since improper servicing may cause unsafe operation.

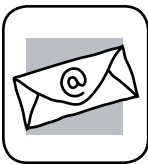

Contact Us

GEAppliances.com

If you are not satisfied with the service you receive from GE, contact us on our Website with all the details including your phone number, or write to:

General Manager, Customer Relations
GE Appliances, Appliance Park
Louisville, KY 40225



Register Your Appliance

GEAppliances.com

Register your new appliance on-line—at your convenience! Timely product registration will allow for enhanced communication and prompt service under the terms of your warranty, should the need arise. You may also mail in the pre-printed registration card included in the packing material.