

# KRK-11

## INSTRUCTION MANUAL

# KENWOOD

Kenwood Corporation

© B62-2102-00 (M)

### FEATURES

- This is an optional accessory for the KCH-16.
- You can connect an external speaker to the interface box.

### SUPPLIED ACCESSORIES

Item	Part Number	Quantity
Interface Box	—	1
Main body panel assembly	—	1
Ground cable	E30-3085-XX	1
Retaining band	J61-0307-XX	1
Retaining bracket	J21-4354-XX	2
Connector	E59-0426-XX	1
Screw set	N99-2069-XX	1
Screw set	N99-2070-XX	1
Instruction manual	B62-2102-XX	1

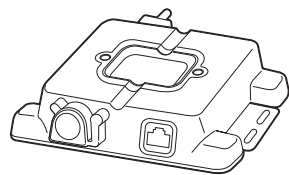

Interface box



Screw set : N99-2069-XX  
(For Interface box)

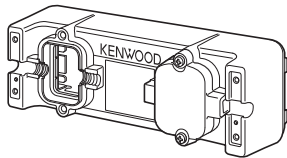

Main body panel assembly

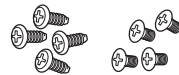

Screw set N99-2070-XX  
(For Main body panel assembly)

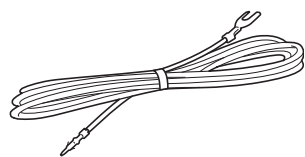

Ground cable



Connector

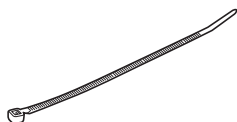

Retaining band

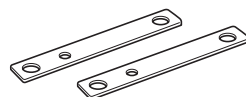

Retaining bracket

### Note:

- ◆ The following instructions are for use by your **Kenwood** dealer, an authorized **Kenwood** service facility, or the factory.
- ◆ Refer to the Service manual for detailed information regarding the installation of the KCH-16.

### INSTALLATION

The following tools and parts are required for installing the handheld control head interface kit.

- Phillips No. 2 screw driver
- KCT-22 Remote Control Cable

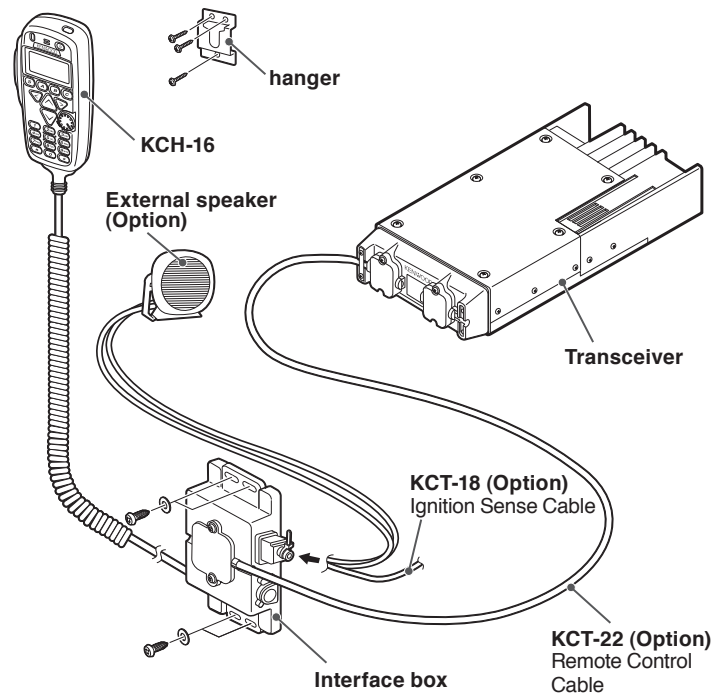

### Note:

- ◆ When connecting the KCH-16 to the Interface box, do not connect the MIC to the programming connector of the Interface box.
- ◆ The programming connector of the interface box is dedicated to programming.
- ◆ The control connector of the interface box is dedicated to the KCH-16; do not use this connector for other equipment.
- ◆ The optional jack is supplied for future expansion. It cannot be used at this time.
- ◆ Do not remove the covers or caps of connectors that are not currently being used.
- ◆ After connecting the KCH-16 and turning on the power, do not remove the KCH-16.