

TAMRON

AF 28 - 105 mm F/4 - 5.6 [IF] (Model 179D)

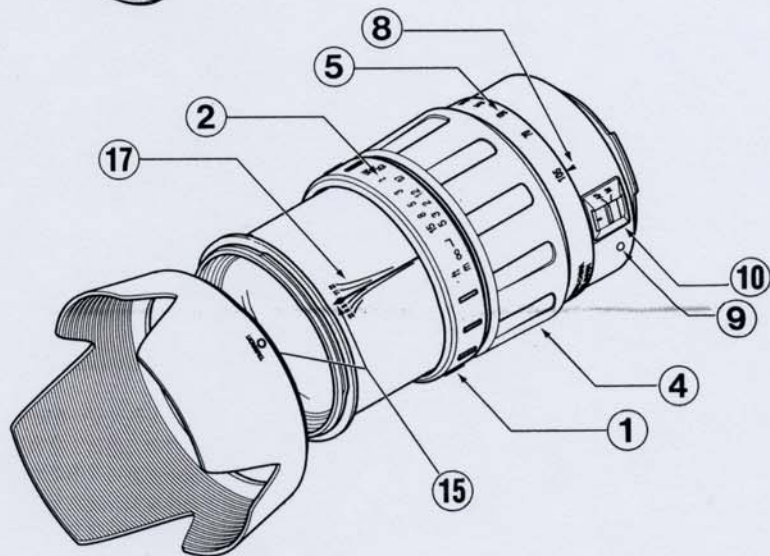

Thank you for purchasing this Tamron lens. Please read this owner's manual carefully before using your new lens. Proper care and maintenance of this lens will result in years of enjoyable use.

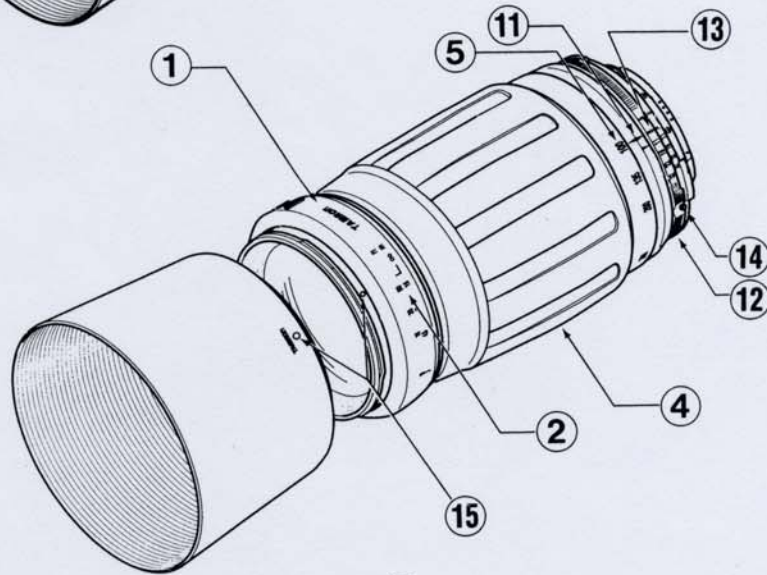
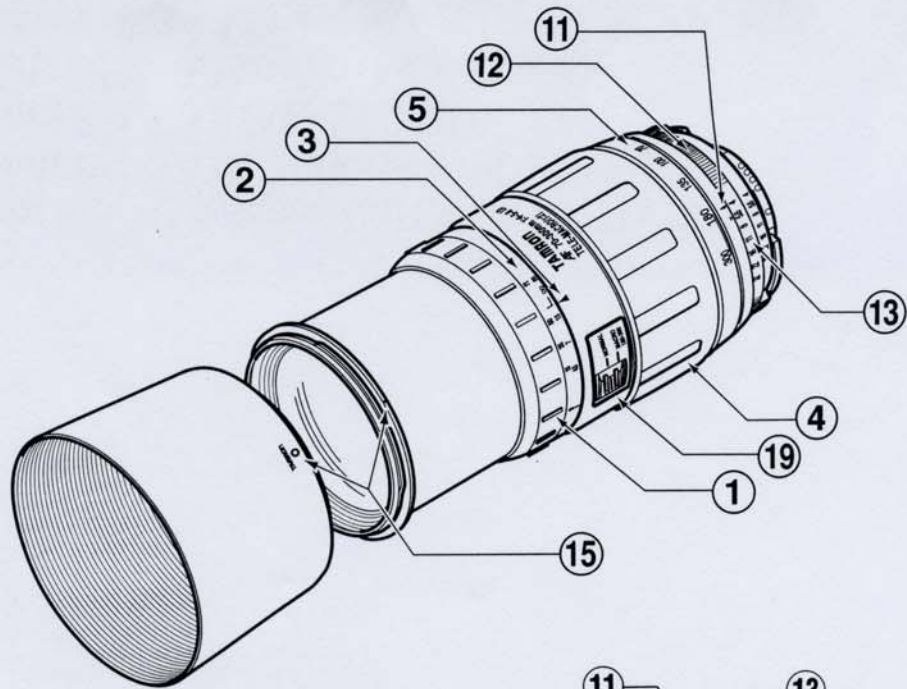

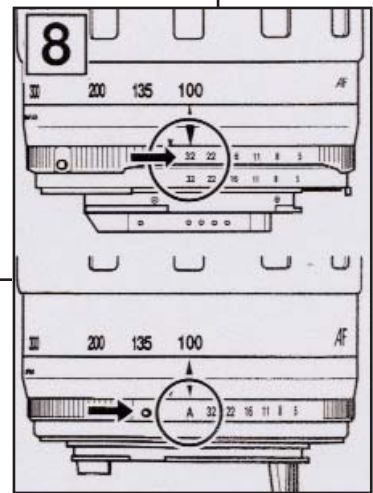
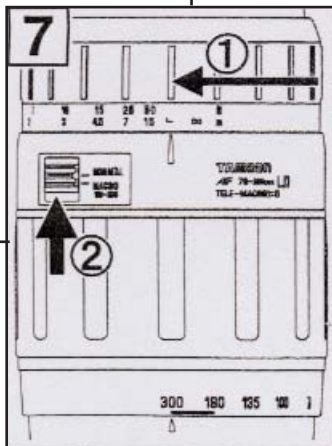
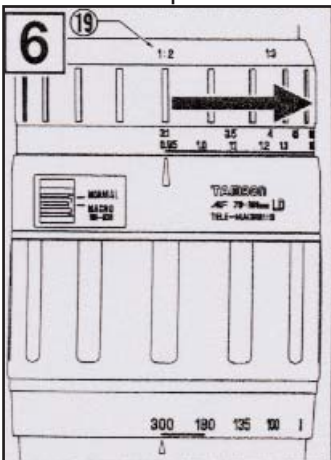
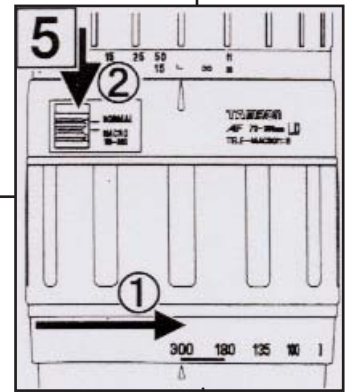
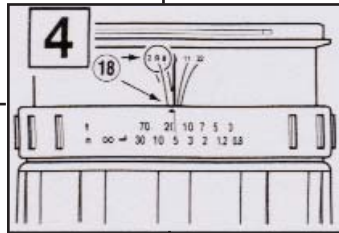
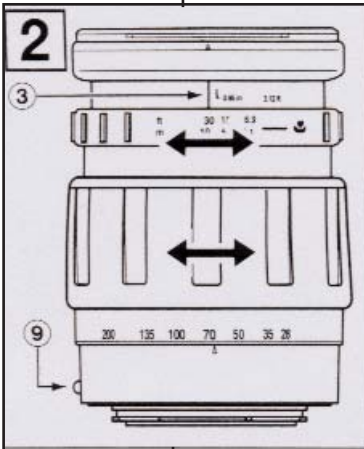
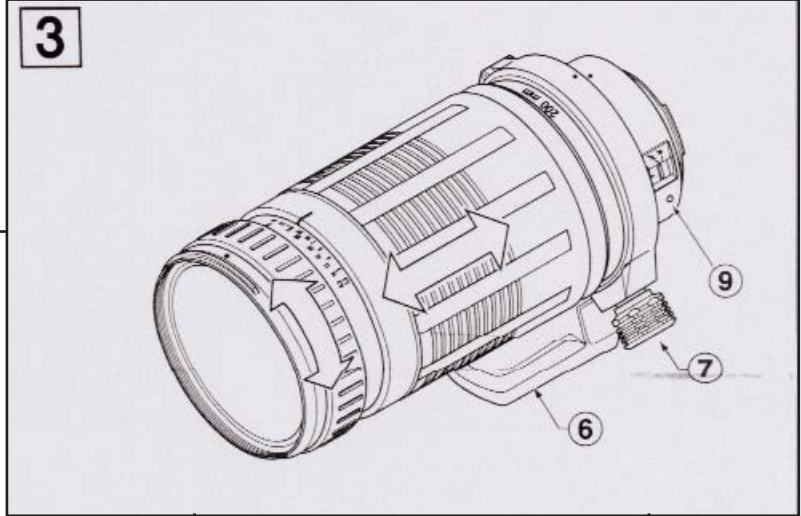
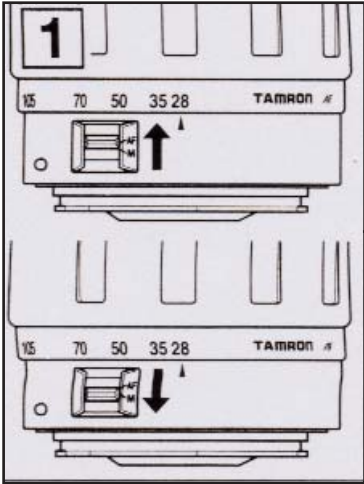

DESCRIPTION OF PARTS

1. Focusing ring
 2. Focus distance scale
 3. Focus distance index
 4. Zooming ring
 5. Zooming scale
 6. Tripod socket
 7. Tripod socket fixing screw
 8. Zoom index
 9. Lens mounting guide
 10. AF/MF selector switch
 11. Aperture / Zoom index
 12. Aperture ring
 13. Aperture scale
 14. AE (minimum aperture) lock
 15. Hood attaching index
 16. Magnification scale
 17. Depth-of-field scale
 18. Infrared index
 19. Macro selector switch
- 6~7 are for Model 175D only
9 is for Canon/Minolta only
10 is for Canon only
12~14 are for Nikon / Pentax only
17 is for Model 179D only
18 is for Model A10 / 179D only
19 is for Model 572D / 772D only

SPECIFICATIONS

	179D
Focal Length	28-105mm
Maximum Aperture	F/4-5.6
Angle of View	75 - 23
Lens Construction (Groups/Element)	12/15
Minimum Focus Distance	0.5m (1.6')
Maximum Magnification Ratio	1:5.6
Filter Size	62mm
Length	73mm (2.9")
Diameter	72mm (2.8")
Weight	305g (10.8oz)

- * Length and maximum diameter indicate the values for the lens with the Nikon mount.
- * Specifications and design are subject to change without notice.

MOUNTING/REMOVING THE LENS

Mounting

After removing the rear cap, place the lens in the camera mount aligning the lens mount index line with that of the camera body (Canon/Minolta/Pentax). For Nikon models, align the lens mount index line with the dot on the camera. Rotate the lens clockwise until it click-locks (counter-clockwise in case of Nikon body). (For details, please refer to the instruction manual of your camera.)

Removal

Push in and hold the lens release button on the camera body while rotating the lens counter-clockwise (clockwise in case of Nikon body.)

FOCUSING

Automatic Focusing (for Nikon/Minolta/Pentax AF SLR)

When the camera is on the autofocus mode, the lens focuses automatically. During AF (Auto Focus) operation, the focusing ring will rotate and its movement should not be hindered.

Automatic Focusing (for Canon-EOS AF SLR)

Set the AF/MF Switch on the lens to "AF" mode. Pressing the shutter release button of the camera will activate the auto-focusing function of the camera. During AF operation, the focusing ring will rotate and its movement should not be hindered.

Manual Focusing

When the lens is used on a Nikon/Minolta/Pentax AF camera, switch the camera to the manual focus mode. When the lens is on a Canon EOS camera, set the lens AF/MF Switch to the "MF" mode. Turn the focusing ring while looking through the viewfinder. The correct focus position is determined when the picture in the viewfinder becomes sharpest. In manual-focus photography, focusing should always be checked through the viewfinder even when shooting at infinity.

* For further details, see the instruction manual of your camera.

INFRARED INDEX (Model A10 and 179D)

It is necessary to adjust the focus point when using black and white infrared film with a red filter. This is normally done by focusing on the subject, reading the value from the distance scale, aligning that value with the infrared index and attaching the red filter. When you need very precise focusing, we recommend shooting a test roll.

ZOOMING

To set your lens to the desired image composition you desire, simply look through the viewfinder and operate the zoom ring.

APERTURE CONTROL & AE SETTING

Canon / Minolta

Your camera controls the aperture depending on the shooting mode in use. Although the aperture value varies in accordance with zooming, the camera itself reads out the change to provide automatic compensation.

Nikon / Pentax

When shooting in programmed AE or shutter-priority AE mode, rotate the aperture ring to the minimum position. For aperture-priority or manual mode, turn the aperture ring to the desired setting. In case of F401/F50 series models, the aperture is set by the camera in accordance with the given camera instructions.

LENS HOOD

A bayonet-type lens hood is provided as a standard accessory. Tamron recommends shooting with the hood attached whenever possible as the lens hood cuts out light, which is harmful to image quality. However, please be aware of the precautions noted below when your camera is equipped with a built-in flash. When the hood is not in use, it can be placed on the front of the lens in reverse:

Attaching the Lens Hood Align the index mark on the hood with the corresponding index mark on the lens. Push the hood onto the lens and then rotate it clockwise to secure. When attaching the lens hood, hold the focusing and zoom control rings so that they are not rotated unintentionally.

TRIPOD SOCKET (Ref. Figs. 9 & 10)

To change the camera from horizontal to vertical position or vice versa, loosen the locking knob for the tripod-attaching base by rotating it counterclockwise, then rotate lens and the camera about the longitudinal axis of the lens. Tighten the locking knob by rotating it in clockwise direction until it stops. (Fig. 9)

To remove the tripod-attaching base, loosen the locking knob, pull it back slightly, and then lift the knob to open the tripod base ring as illustrated in Fig. 10. When removing the tripod-attaching base, hold the lens and the camera securely to prevent them from both accidentally falling.

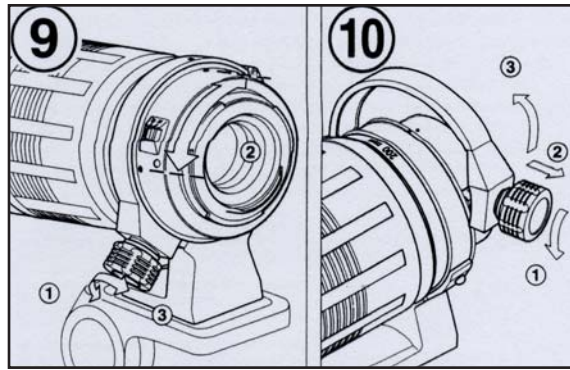

Fig. 9

Altering camera between vertical & horizontal positions

1. Loosen lock knob by rotating knob counterclockwise.
2. Turn camera and lens so as position alignment marks meet each other.
3. Tighten lock knob by rotating knob clockwise.

Fig. 10

Detaching tripod-attaching base

1. Loosen lock knob by rotating knob counterclockwise.
2. Pull out lock knob slightly.
3. Turn attaching ring upward while holding locking knob.

* When detaching tripod-attaching base, hold camera and lens securely, not to accidentally drop your valuable equipment.

CHECKING DEPTH-OF-FIELD

When you set the focus of a particular subject, there is an area in front of you and behind your subject that will also be in focus.

The depth-of-field table shows aperture values horizontally and ranges vertically. If, for example, the aperture is F8 and the shooting range is 5m (Focal length 400mm), the depth-of-field value is 4.96 (m)-5.04 (m) where F8 in the horizontal column and 5m in the vertical column intersect. If your camera has a preview mechanism, the depth-of-field effect can be confirmed in the viewfinder. For further details, see the instruction manual of your camera.

PRECAUTIONS IN SHOOTING

Tamron AF 28 - 105 (Model 179D) employs an internal Focusing (IF) system to achieve a remarkable 0.5m (1.6 feet) M.O.D. (Minimum Object Distance) at 105mm. Because of the characteristics of this optical design, the 105mm coverage, at the distances other than infinity, is wider than that coverage of lenses using an ordinary focusing system.

When the built-in flash on the camera is used, symptoms such as corner illumination fall-off or vignetting at the bottom part of the image may be observed, especially at the wider-angle range. This is due to the inherent limitation of the coverage of the built-in flash, and/or the relative position of the flash to the edge of the lens barrel, which causes shadows on the image. Accordingly, we recommend not using the built-in flash at wider-angle settings.

Please refer to the section of your camera's instruction manual pertaining to the use of the built-in flash, since the angles of coverage of the flashes differ between camera models.

When you use a built-in flash, make sure to detach the lens hood.

Certain camera models may indicate the maximum and minimum aperture values of the lens in approximate numbers. This is inherent to the design of the camera and not an indication of error.

Do not use the lens hood when you shoot with your camera's built-in flash. Even without the lens hood, an arched-shape shadow may be observed at the bottom portion of the picture when using the built-in flash. Tamron recommends using an optional flash unit (clip-on grip type) when use of flash is necessary.

When using the lens in the telephoto focal range, it may be necessary to use a tripod to avoid camera shake. Using high-speed film (ISO 400 or faster) with a fast shutter speed is also helpful to reduce the effect of camera shake.

TO ENSURE LONG-TERM SATISFACTION

Avoid touching the glass element surface. Use a photographic lens cloth or blower brush to remove dust from the lens element surface. When not using the lens, always place a lens cap on it for protection.

Use a lens cleaning tissue or lint cloth with a drop of cleaning solution to remove fingerprints or dirt on the glass lens surface with a rotary motion from the center to edge. Use a silicon cloth to clean your lens barrel only.

Mildew is an enemy of your lens. Clean the lens after shooting near water or in any humid place. If you find mildew on your lens, consult a repair shop or nearby photographic store.

When using your equipment [camera(s) and lens(es)] in an environment where the temperature changes from one extreme to the other, make sure to put your equipment temporarily in a case or plastic bag for a length of time in order for the equipment to go through a gradual temperature shift. This will reduce potential equipment troubles.