



Linn AV Loudspeaker User's Guide



# Important safety information

Explanation of symbols used in this manual and on the product:



This symbol is intended to alert the user to the presence of uninsulated dangerous voltages within the enclosure of sufficient magnitude to cause electric shock.



This symbol is intended to alert the user to the presence of important maintenance and servicing information in the instruction and service manuals.

## **CAUTION**

TO REDUCE THE RISK OF ELECTRIC SHOCK DO NOT REMOVE THE COVER.

NO USER SERVICEABLE PARTS INSIDE.

REFER SERVICING TO QUALIFIED SERVICE PERSONNEL.

WARNING: SHOCK HAZARD. DO NOT OPEN.

*AVIS: RISQUE DE CHOC ELECTRIQUE. NE PAS OUVRIR.*

CAUTION: REPLACE FUSE WITH SAME TYPE AND RATING.

*ATTENTION: UTILISER UN FUSIBLE DE RECHANGE DE MÊME TYPE.*

DISCONNECT SUPPLY CORD BEFORE CHANGING FUSE.

*ATTENTION: DEBRANCHER AVANT DE REMPLACER LE FUSIBLE.*

## **WARNING**

TO REDUCE THE RISK OF FIRE OR ELECTRIC SHOCK DO NOT EXPOSE THIS APPLIANCE TO RAIN OR MOISTURE.

## **MAINS PLUGS**

This appliance is supplied with a non-rewireable mains plug for the intended country.

Replacement mains leads can be obtained from your Linn retailer. Should you need to change the plug please dispose of it carefully.

A plug with bared conductors is dangerous if engaged in a live socket.

The Brown wire must be connected to the Live (Line) supply pin.

The Blue wire must be connected to the Neutral supply pin.

The Green/Yellow wire must be connected to the Earth (Ground) supply pin.

Please contact your retailer or a competent electrician if you are in any doubt.

## GENERAL SAFETY INSTRUCTIONS

1. Read instructions. Read the safety and operating instructions before operating the appliance.
2. Retain instructions. Retain the safety and operating instructions for future reference.
3. Heed warnings. Observe all warnings on the appliance and in the operating instructions.
4. Follow instructions. Follow all operating and use instructions.
5. Water and moisture. Do not use the appliance near water, for example near a bathtub, washbowl, kitchen sink, laundry tub, in a wet basement, or near a swimming pool and the like.
6. Carts and stands. Use only with a cart or stand that is recommended by the manufacturer.
- 6a. An appliance and cart combination should be used with care. Quick stops, excessive force, and uneven surfaces may cause the appliance and cart combination to overturn.
7. Wall or ceiling mounting. Mount to a wall or ceiling only as recommended by the manufacturer.
8. Ventilation. Site the appliance so that its location or position does not interfere with its proper ventilation. For example, the appliance should not be situated on a bed, sofa, rug, or similar surface that may block the ventilation openings, or placed in a built-in installation such as a bookcase or cabinet that may impede the flow of air through the ventilation openings.
9. Heat. Site the appliance away from heat sources such as radiators, heaters, stoves, or other appliances (including amplifiers) that produce heat.
10. Power sources. Connect the appliance to a power supply only of the type described in the operating instructions or marked on the appliance.
11. Grounding or polarisation. Do not defeat the precautions taken to ground or polarise the supply to the appliance.
12. Power cord protection. Route power cords so that they are not likely to be walked on or pinched by items placed upon or against them, paying particular attention to cords at plugs, power sockets, and at the point where they exit from the appliance.
13. Protective attachment plug. As a safety feature the product is equipped with an attachment plug containing overload protection. See the instruction manual about resetting or replacing the plug. Should the plug need replacing ensure that a replacement is used which has the same overload protection as the original.
14. Cleaning. The product should be cleaned only as recommended by the manufacturer.
15. Power lines. An outdoor antenna should be located away from power lines.
16. Outdoor antenna grounding. If an outdoor antenna is connected to the tuner/receiver ensure that the antenna system is grounded to provide some protection against voltage surges and static build up.  
In the USA see article 810 of the National Electrical Code ANSI/NFPA 70 concerning installation requirements.
17. Non-use periods. Unplug the power cord from the outlet if the product will be unused for a long period of time.
18. Objects and liquid entry. Take care not to let objects or liquids fall into the product.
19. Damage requiring service. The product should be serviced by qualified personnel if:
  - a) The power cord or plug has been damaged.
  - b) Objects or liquid have fallen into the product.
  - c) The product has been exposed to rain.
  - d) The product does not appear to operate normally or exhibits a marked change in operation.
  - e) The product has been dropped or the enclosure damaged.
20. Servicing. Don't attempt to service the product beyond that described in the operating instructions. All other servicing should be referred to qualified service personnel.

## **UK USERS PLEASE READ THIS IMPORTANT SAFETY INFORMATION**

### **Fuse replacement**

This appliance is fitted with a non-rewireable 13 Amp mains plug. The plug contains a 5 Amp fuse. If the fuse has blown it can be replaced as follows:

- a) Pull out the red fuse cover/carrier.
- b) Remove and dispose of the blown fuse.
- c) Fit a new 5 Amp BS1362 approved fuse into the carrier and push the carrier back into the plug.

Always ensure the fuse cover is fitted. If the fuse cover is missing do not use the plug. Contact your Linn retailer to obtain a replacement fuse cover.

Fuses are for fire protection and do not protect against electric shock.

### **Mains plug replacement**

Should your mains plug need replacing and you are competent to do this proceed as follows. If you are in doubt contact your Linn retailer or a competent electrician.

- a) Disconnect the plug from the mains supply.
- b) Cut off the plug and dispose of it safely. A plug with bared conductors is dangerous if engaged in a live socket.
- c) Only fit a 13 Amp BS1363A approved plug with a 5 Amp fuse.
- d) The cable wire colours or a letter will be marked at the connection points of most quality plugs.

Attach the wires securely to their respective points. The Brown wire must go to the Live pin, the Blue wire must go to the Neutral pin, and the Green/Yellow wire must go to the Earth pin.

- e) Before replacing the plug top ensure that the cable restraint is holding the outer sheath of the cable firmly and that the wires are correctly connected.

### **WARNING**

THIS APPLIANCE MUST BE EARTHED.

### **Replacing the fuse**

Should the mains fuse blow replace it only with an equivalent part. The fuse holder is located just below the mains inlet socket. To replace the fuse disconnect the product from the mains supply. Using a flat blade screwdriver remove and replace the fuse. If the fuse blows a second time there is a fault in the product. Contact your local retailer.

**Fuse ratings.** See specifications section.

AV 5150 Active Isobarik Bass Speaker 220V /230V /240V setting T3.15A.

115V /100V setting (if available): T6.3A. CSA approved.

### Replacing the fuse

Should the mains fuse blow replace it only with an equivalent part. The fuse holder is located just below the mains inlet socket. To replace the fuse disconnect the product from the mains supply. Using a flat blade screwdriver remove and replace the fuse. If the fuse blows a second time there is a fault in the product. Contact your local retailer.

### Mains voltage operating range

#### AV 5150 Active Isobarik Bass Speaker

115V, 230V +/- 10%, 50-60Hz.

### Setting the mains operating voltage

All products with a voltage selector switch must be set to the local mains supply voltage before connecting to the mains supply.

Please check the setting of the voltage selector switch at the mains input socket before connecting the product to a mains supply.

To set the mains operating voltage unplug the mains supply cable and using a flat blade screwdriver turn the selector switch to the appropriate voltage.

**Warning!!** The power supply may be destroyed if it is connected to 240V when set for 120V.

### Power consumption

Product	Operate mode	Standby mode
AV 5150 Active Isobarik Bass Loudspeaker	25W-850W	5W

### Switching the product on and off – standby operation

#### AV 5150 Active Isobarik Bass Speaker

The AV 5150 contains circuitry which senses the presence of an audio signal and powers up the product. The AV 5150 remains powered up for several minutes after the audio signal disappears, then reverts to standby mode, consuming very little power. Standby mode is indicated by the front panel indicator glowing red. Full operation is indicated by the front panel indicator glowing green. The mains switch (behind the control area cover) switches the product OFF completely or ON. If, after three minutes, the AV 5150 does not sense an audio signal it will switch to standby mode.

### Positioning the products and heat

All electronic products generate some heat. Audio products, in particular audio power amplifiers, have to handle and dissipate large amounts of power. It is essential to provide adequate ventilation to allow this heat to dissipate into the environment. All Linn products are fully protected against overheating and will shut down before any component becomes over heated. However the products will last longer and perform better if they are kept cool. The AV 5150 Active Isobarik Bass Speaker keeps its power amplifier semiconductors cool by transferring the heat on to the extruded heatsink. As a result the extrusion will become warm in use.

### Copyright and acknowledgements

Copyright © Linn Products Limited.

Linn Products Limited, Floors Road, Waterfoot, Glasgow, G76 0EP, Scotland, United Kingdom.

All rights reserved. No part of this publication may be reproduced, stored in a retrieval system, or transmitted, in any form or by any means, electronic, mechanical, photocopying, recording, or otherwise, without the prior written permission of the publisher.

Printed in the United Kingdom.

AV 5101, AV 5103, AV 5105, AV 5110, AV 5120, AV 5140, and AV 5150 are trademarks of Linn Products Limited.

The information in this manual is furnished for informational use only, is subject to change without notice, and should not be construed as a commitment by Linn Products Limited. Linn Products Limited assumes no responsibility or liability for any errors or inaccuracies that may appear in this manual.

Part no: PACK 739

This manual was produced by Human-Computer Interface Ltd, Cambridge, England.

## Declaration of Conformity

Linn Products Ltd declare that this product is in conformance with the Low Voltage Directive 73/23/EEC and Electromagnetic Compatibility 89/336/EEC as amended by 92/31/EEC and 93/68/EEC.

The conformity of the designated product with the provisions of Directive number 73/23/EEC (LVD) is proved by full compliance with the following standards:

Standard number	Date of issue	Test type
EN60065	1993	General requirements Marking Ionizing Heating under normal conditions Shock hazards under normal operating conditions Insulation requirements Fault conditions Mechanical strength Parts connected to the mains supply Components Terminal devices External flexible cords Electrical connections and mechanical fixings

The conformity of the designated product with the provisions of Directive number 89/336/EEC (EMC) is proved by full compliance with the following standards:

Standard number	Date of issue	Test type
EN55013	1994	Conducted emissions
EN55013	1994	Absorbed emissions
EN60555-2	1987	Harmonics
EN60555-3	1987	Voltage fluctuations
EN55020	1994	Immunity

### FCC notice

NOTE: This equipment has been tested and found to comply with the limits for a Class B digital device, pursuant to Part 15 of the FCC Rules. These limits are designed to provide reasonable protection against harmful interference in a residential installation. This equipment generates, uses and can radiate radio frequency energy and, if not installed and used in accordance with the instructions, may cause harmful interference to radio communications. However, there is no guarantee that interference will not occur in a particular installation.

If this equipment does cause harmful interference to radio or television reception, which can be determined by turning the equipment off and on, the user is encouraged to try to correct the interference by one or more of the following measures:

- Reorient or relocate the receiving antenna.
- Increase the separation between the equipment and receiver.
- Connect the equipment into an outlet on a circuit different from that to which the receiver is connected.
- Consult the dealer or an experienced radio/TV technician for help.

# contents

---

## **introduction.....1**

The Linn AV System.....1
AV 5103 System Controller.....1
AV 5101 Personal Handset.....2
AV 5105 Stereo Power Amplifier.....2
AV 5140 Floor-Standing Loudspeaker.....3
AV 5120 Compact Loudspeaker.....3
AV 5110 Local Loudspeaker.....4
AV 5150 Active Isobarik Bass Speaker.....4
...Making it real.....5
About the AV 5105 Stereo Power Amplifier.....6

## **using the AV loudspeakers.....7**

Using the AV 5140 and AV 5120 loudspeakers.....7
Using the AV 5150 Active Isobarik Bass Loudspeaker.....9
Using the AV 5110 Local Loudspeaker.....10

## **setting up the AV 5140 and AV 5120.....11**

Unpacking.....11
Positioning AV 5140 loudspeakers.....11
Positioning the AV 5120 loudspeaker.....13
Connecting the AV 5140 or AV 5120 loudspeakers.....15
Removing the grilles and cleaning the loudspeakers.....18

## **setting up the AV 5110.....19**

Unpacking.....19
Positioning AV 5110 loudspeakers.....19
Connecting the AV 5110.....22

## **setting up the AV 5150 23**

Unpacking.....23
Positioning.....23
Removing the base.....25
Connecting the AV 5150 Active Isobarik Bass Speaker.....26
Adjusting the AV 5150.....28

## **guarantee and service.....31**

## **technical information.....32**

AV 5140 Front Loudspeaker.....32
AV 5120 Compact Loudspeaker.....32
AV 5110 Local Loudspeaker.....33
AV 5150 Active Isobarik Bass Speaker.....33

## **Index.....35**



# introduction

---

## The Linn AV System

To get the most out of a film you have to do more than simply watch it: you have to experience it fully, exactly as its creators intended. That means images and sound must be married together perfectly, giving you the same emotional impact you would receive in the cinema itself. Without sound of the very highest quality, every film lacks an essential dimension – and so does your pleasure in viewing it.

In designing your Linn AV system, we have set out to create the ultimate experience of cinema and music in the home and every component has been carefully designed to give you exactly that. No-one knows more than Linn about designing music systems for the home and we have used that unique experience and know how to create an AV system which gives you the same accuracy and purity of sound, even when you are listening to special effects in an action movie.

## AV 5103 System Controller

The heart of the system is the AV 5103 System Controller. This controls your audio and video sources, to let you choose what you want to watch or listen to. It can control analogue signals, from a tape recorder or FM tuner, for example; digital signals, from a CD player or a LaserDisc player, and video sources, from a TV tuner, video recorder and LaserDisc player. It also decodes surround encoded materials, including AC-3, to give you a complete surround sound experience. With its informative two-line text display, and the option of on-screen graphics, the AV 5103 System Controller is both powerful and simple to use. Most operations involve just one key-press on the front panel or handset.

Despite the simplicity of its front panel, however, almost every aspect of the System Controller can be configured in exactly the way you want. You can define and control everything: the inputs you use for each of your sources, the name of those sources, the surround-sound decoding options and loudspeaker settings. The System Controller also provides a sophisticated range of audio and video recording options, allowing you to record several sources simultaneously without affecting what you are watching or hearing.



---

## AV 5101 Personal Handset

The power and flexibility of the Linn AV system is entirely under your control, from wherever you are in the room, with the AV 5101 Personal Handset. This uses a powerful infra-red signal to allow you to select any of the AV 5103 System Controller's functions with a few simple key presses.

Its uniquely contoured shape makes it extremely comfortable to hold, and the keys are large, and easy to read and use. It is also equally suitable for table-top use, if you prefer.

As well as controlling the Linn AV system, and any other Linn products you may own, the Personal Handset can also learn the commands for your other equipment, so that your whole system can be controlled with a single handset.



## AV 5105 Stereo Power Amplifier

The AV 5105 Stereo Power Amplifier is the ideal companion to the System Controller in your AV system. It has the power to cope with the most demanding cinema effects, while providing the purity and low distortion needed for the perfect reproduction of music.

Each AV 5105 Stereo Power Amplifier will drive two of the loudspeakers in your system, and for the best possible sound we recommend you divide the output of one AV 5105 Stereo Power Amplifier to drive the bass and treble sections of your centre speaker separately.



---

## AV 5140 Floor-Standing Loudspeaker

The AV 5140 Floor-Standing Loudspeaker is the perfect choice for use as the front speakers in a surround sound installation. With film, TV, video, or music the outstanding bass performance of the AV 5140 Floor-Standing Loudspeakers, combined with their natural reproduction of voice and music, will provide you with a totally absorbing and breathtaking cinematic experience. Their unique stylish shape ensures that they enhance, rather than dominate, your home.



## AV 5120 Compact Loudspeaker

The centre loudspeaker is fundamental to a good AV system because it has the task of reproducing the most critical information for music and cinema sources. We therefore designed the AV 5120 Compact Loudspeaker without any compromises to give a superior full-range response, together with especially good bass handling.

As well as giving superb reproduction of music it reproduces speech with particular accuracy, making it ideal for use with film soundtracks. We also carefully matched it to the AV 5140 Floor-Standing Loudspeakers so that sounds which pan across and move between the speakers sound both accurate and highly dramatic. This gives you the most realistic possible impression when listening to film and video soundtracks.

The AV 5120 drive units are shielded to ensure that there is no interference if you place it next to your television.



---

### AV 5110 Local Loudspeaker

The rear loudspeakers in a surround system are important in creating a spacious sound for music and provide background noises and special effects in film soundtracks. These need to be capable of handling the full dynamic range for AC-3 but only limited range for ProLogic. The AV 5110 Local Loudspeakers were designed to be compact and stylish, so that they can be positioned easily in any room.

Despite their size they produce a deceptively full sound with excellent bass response. For even better performance, and especially if you are using AC-3, a recommended alternative is to use a pair of AV 5120 or AV 5140 Floor-Standing Loudspeakers as the rear surround speakers.



### AV 5150 Active Isobarik Bass Speaker

The AV 5150 Active Isobarik Bass Speaker extends the bass performance of the whole system to give you totally involving cinematic effects and enhance the impact of music. We designed the AV 5150 Active Isobarik Bass Speaker to reproduce bass sounds as faithfully as our full-range loudspeakers, with the result that its contribution to the overall sound is extremely natural and unobtrusive. Because low frequency sounds are not directional you can position the bass speaker anywhere convenient in the room.

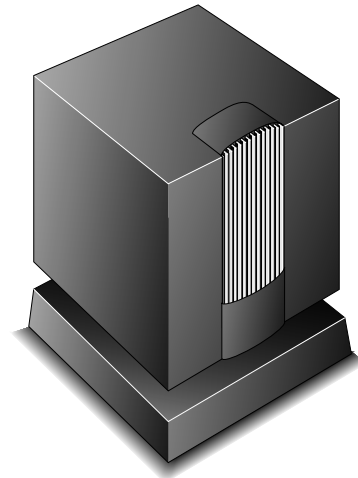

---

## ...Making it real

The Linn AV system has been designed to give you the most exciting and satisfying experience of cinema it is possible to achieve in the home. Our aim is to bring you the complete film as its creators intended: with images and sound working together in the most memorable way. To achieve this demanding objective we have designed each of our components to give outstanding performance in their own right while ensuring that each of them work perfectly with each other.

The result is an integrated system that will give you the most rewarding experience you can achieve from watching a film, or listening to a music recording: bringing a new dimension to the way you experience cinema in the home.

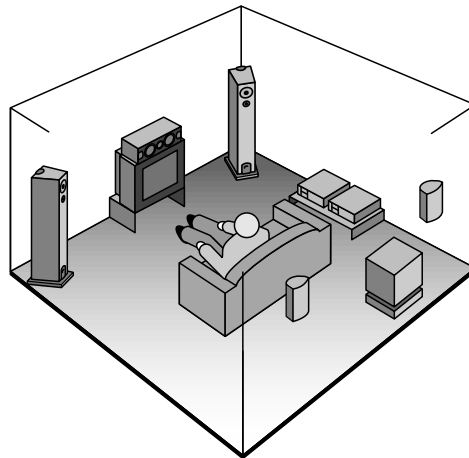

---

## About the AV 5105 Stereo Power Amplifier

The Linn AV 5105 Stereo Power Amplifier is intended for use in high performance audio and audio/video systems. It combines high output power, ruggedness, and ease of use with our passion for quality. It draws on years of experience of designing and making high quality audio power amplifiers.

Inside the compact case are two completely independent electrically isolated channels with fully regulated power supplies giving 'dual mono' performance. The signal path is DC coupled and servo controlled for the lowest distortion, cleanest, least coloured sound. The output stage is highly derated for cool, reliable operation, and the protection circuitry protects extensively against accidents or abuse.

A signal sensing circuit detects the presence of audio above a very low level and turns on the main power supplies to the amplifier, bringing the power amplifier channel from a very low standby power consumption to full operation. It reverts to the standby condition a few minutes after the input signal disappears. This is particularly useful in multi-channel surround sound systems.

The AV 5105 accepts the Linn active crossover modules, automatically detecting their presence and switching them in circuit as soon as they are plugged in. This makes playback system upgrades easy.

## using the AV loudspeakers

---

This chapter gives advice on selecting the right AV loudspeakers, based on the requirements of your AV system.

### Using the AV 5140 and AV 5120 loudspeakers

The AV 5140 Front Loudspeaker is the ideal choice for the main left and right loudspeakers in an AV system, or for the rear surround speakers. The AV 5120 Compact Loudspeaker is particularly suitable for use as the centre speaker, but is also an excellent choice for the main left and right or rear loudspeakers. The AV 5140 and AV 5120 are tonally matched, so the balance of sound will be perfect whatever combination you decide on.

#### Using the AV 5140s as front loudspeakers

A recommended configuration is to use two AV 5140 loudspeakers as the front loudspeakers, in conjunction with an AV 5120 placed either above or below the television. The midrange units of the AV 5140s are at the ideal height for providing natural reproduction of a film soundtrack when positioned either side of a television screen.

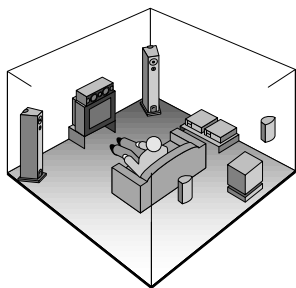

The AV 5120 uses the same drive units as the AV 5140, so that sounds that pan across and move between the loudspeakers remain convincingly natural as they move. This ensures that you get a very realistic and natural impression when listening to film and video soundtracks.

A pair of AV 5110 Local Loudspeakers are recommended as the rear surround speakers due to their compact size and versatility, and an AV 5150 Active Isobarik Bass Loudspeaker is an excellent addition to the system for dramatic cinema effects.

#### Using a pair of AV 5120 loudspeakers as main loudspeakers

The compact design of the AV 5120 loudspeaker makes it ideal for use as the main loudspeakers in an AV system where you do not have room for conventional floor-standing loudspeakers. They can be positioned on a bookcase or shelf, or fixed directly to the wall using a Linn adjustable BRAKIT.

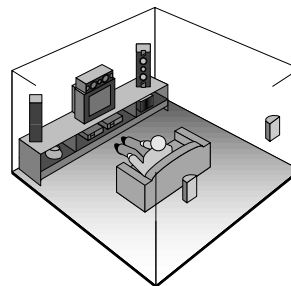

### Using AV 5140 Floor-Standing Loudspeakers as rear surround speakers

An ideal AC-3 AV system uses two AV 5140 Floor-Standing Loudspeakers in a conventional stereo configuration, supplemented by an AV 5120 Compact Loudspeaker as the centre speaker and, for the full dynamic range required, two further AV 5140 or AV 5120 loudspeakers at the rear.

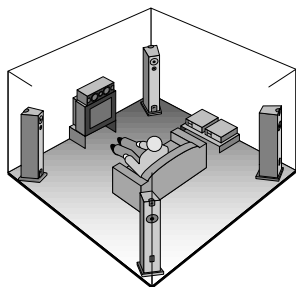

This system will give you breathtaking sound from films and music, whether you are listening to the dynamic climax in an action movie, or the subtle nuances in a musical performance.



## **Using the AV 5150 Active Isobarik Bass Loudspeaker**

Any AV or hi-fi system can be dramatically enhanced by the addition of the AV 5150 to extend the bass performance well below the limit of full-range loudspeakers.

The 5150 is an omni-directional low-frequency loudspeaker, incorporating 12" Isobarik coupled drivers with integrated active amplification. This loudspeaker delivers its impact without intruding or detracting from realism, with an accurate tonal performance for both music and cinema sound effects.

The AV 5150 offers great flexibility in configuring the system providing extreme low bass enhancement to a system which already has capable bass speakers or providing balance to a system based on small speakers with limited bass capability. The AV 5150 can be configured to blend in with and enhance almost any system configuration.

## Using the AV 5110 Local Loudspeaker

The AV 5110 is exceptionally versatile, perfect for any situation where you need a small loudspeaker with an excellent full-range performance.

In an AV system the AV 5110 is ideal for use as the rear loudspeakers, and they can be placed on a shelf, mounted on stands, or wall-mounted using Linn BRAKITs.

AV 5110 loudspeakers are also ideal for a second room system, so that you can listen to the music from your main system elsewhere in your home. The AV 5103 System Controller provides duplicate main left and right outputs to make it easy to set up a second system and a KNEKT output to allow full audio/video distribution.

# setting up the AV 5140 and AV 5120

## Unpacking

Each AV 5140 or AV 5120 loudspeaker comes in a box with the following accessories:

- A terminal key, for removing the loudspeaker terminals.
- Four tri-wire links (AV 5140) and two bi-wire links (AV 5120).
- Four red and four black banana plugs (AV 5140), two red and two black banana plugs (AV 5120).
- Eight spiked feet with locking nuts (AV 5140), or four rubber feet (AV 5120).
- This manual.

In addition, each AV 5140 loudspeaker is supplied with:

- A stand, which can be attached to the loudspeaker.
- Eight cap screws and washers, to attach the stand.

A full-length grille, which can be attached to the front of the loudspeaker, is available as an optional extra (Linn part numbers: 5140 GRILLE and 5120 GRILLE).

We recommend you retain the packaging in case you need to transport the loudspeakers at a later date.

## Positioning AV 5140 loudspeakers

### Positioning the AV 5140 loudspeakers near a rear wall

The rear-facing bass unit allows the AV 5140 loudspeakers to be positioned much closer to a wall, or to the corner of a room, than conventional loudspeakers, without degrading the bass performance. Because bass frequencies are not directional, the rear-facing bass unit sounds as immediate and direct as the front-facing bass unit in most conventional loudspeakers, and it is hard to believe that the sound is not coming from the front of the loudspeaker.

They will produce good bass performance even when positioned as close as 150mm (6") from a rear wall. If positioned in a corner they should be at least 150mm (6") from each wall:

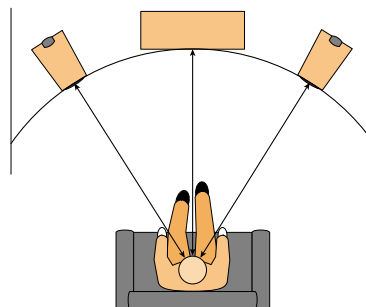

The spacing between the AV 5140 loudspeakers should be about two thirds of the width of the room, and this should be about the same as the distance from your listening position to each speaker. They will also benefit from being angled in slightly towards the listener.

### Using the AV 5140 loudspeakers with a centre loudspeaker

If you are using the AV 5140 loudspeakers in an AV system, and you have a centre loudspeaker, they will benefit from being placed further apart. The centre loudspeaker should be slightly closer to the rear wall than the AV 5140 loudspeakers, so that the distance from the listener to each the loudspeaker is the same.

### Positioning the AV 5140 loudspeakers near a television

The AV 5140 loudspeakers are fully screened and can therefore be placed as close as 50mm (2") to a television without causing interference to the television picture.

### Fitting the stands

The AV 5140 loudspeakers are supplied with bases, and for stability we recommend you fit these to the loudspeakers.

Screw each stand onto the loudspeaker using the four cap screws and washers provided.

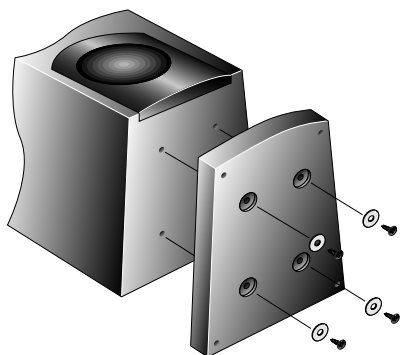

### Adjusting the feet

The AV 5140 loudspeakers are supplied with adjustable spiked feet. To achieve the full performance from your loudspeakers you should adjust the spikes so that the loudspeakers are completely stable, with all feet in contact with the floor.

The standard spikes, which have been designed for use with carpeted floors, penetrate through the weave of the carpet without flattening the pile.

If you have wooden or solid floors you should use the spikes in conjunction with Linn SKEETS, to provide a firm base and protect the floor from scratches. These are available from your Linn dealer.

To adjust the feet loosen the locking nut using the spanner provided, move the spike by screwing or unscrewing it, and then *lightly* tighten the locking nut.

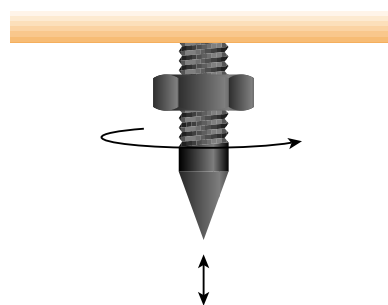

## Positioning the AV 5120 loudspeaker

### Using the AV 5120 as a centre loudspeaker

The AV 5120 is the perfect choice for use as the centre loudspeaker in a surround sound installation. The AV 5120 should be placed at the same height from the floor as the midrange units in the main left and right loudspeakers. For example, when used with a pair of AV 5140 loudspeakers the ideal position is approximately 880mm (34.5") from the floor. It should be placed slightly closer to the rear wall than the main left and right loudspeakers, so that the distance from the listener to each loudspeaker is the same.

### Positioning the AV 5120 loudspeaker above or below a television

The AV 5120 can conveniently be positioned either under or above the television set, depending on the height of your television. The AV 5120 is fully magnetically screened so that it will not affect the television picture:

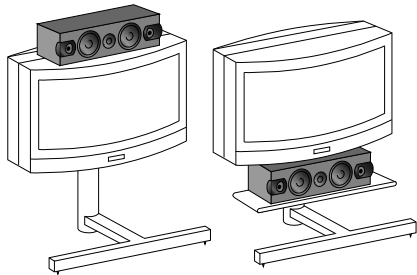

Alternatively, it can be placed behind a projection screen, or built into an AV cabinet.

The four rubber feet should be fitted to the base of the loudspeaker to ensure that it does not move or vibrate during use:



### Using a pair of AV 5120 loudspeakers as main loudspeakers

If you are using AV 5120 loudspeakers as the main left and right loudspeakers in a system, their spacing should be about two thirds of the width of the room, and this should be about the same as the distance from your listening position to each speaker. They will also benefit from being angled in slightly towards the listener.

When positioned in a corner or near a wall you should leave at least 75mm (3") between each wall and the rear of each loudspeaker.

The four rubber feet should be fitted to the end of the loudspeaker to ensure that it does not move or vibrate during use:

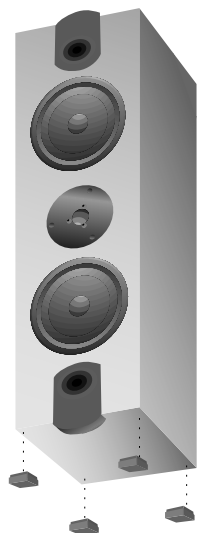

#### **Wall mounting with a BRAKIT**

You can mount an AV 5120 loudspeaker on the wall with a Linn BRAKIT, which is available separately from your Linn retailer (part number BRAKIT/1). This provides a secure and rigid fixing to the wall, and allows you to adjust the angle of the loudspeaker to point it towards the listening position.

BRAKITs are provided with full instructions for fixing to the wall, and to the rear of the loudspeaker.

## Connecting the AV 5140 or AV 5120 loudspeakers

This section explains how to connect AV 5140 or AV 5120 loudspeakers with the rest of your system.

The AV 5140 loudspeaker provides separate connections to the treble, midrange, and bass crossovers and drivers, and the AV 5120 loudspeaker provides separate connections to the treble and midrange/bass crossovers and drivers. You can use separate cables between the power amplifier and each section of the loudspeaker (bi-wiring or tri-wiring), or to use a separate power amplifier for each section of the loudspeaker (bi-amping or tri-amping).

Using separate cables for each driver improves the subjective performance of the loudspeakers by reducing the coupling between the signals.

### Using bare wires

The sockets are designed so you can connect to them using either plugs or bare wires. To use bare wire connections undo the terminal collar, using the key provided, and insert the wire through the hole in the pillar. Then tighten the terminal collar to secure the wire.

### Installing the linking plates

Use the key provided to remove the adjacent pairs of terminal collars, install the linking plate, and replace the terminal collars.

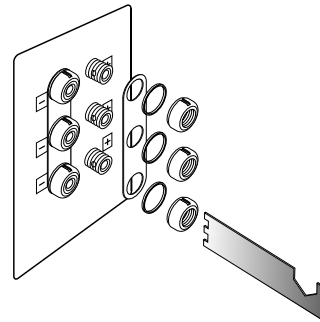

AV 5140

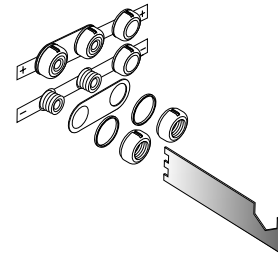

AV 5120

**WARNING:** You should only remove one set of terminal collars at a time, or there is a risk that the circuit board can fall inside the cabinet.

On the AV 5120 do not remove the blanked terminals, and do not connect to these unless your AV 5120 has been specially modified for tri-amping by your dealer, or you may damage your amplifier.

### Single-wiring

To single-wire an AV 5140 or AV 5120 install the linking plates between the negative sockets and positive sockets, as shown in the illustration.

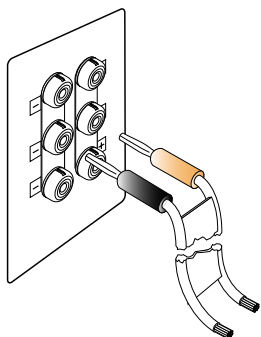

Then connect to the amplifier as shown in the illustration, using Linn K20 cable.

### Bi-wiring or bi-amping

To bi-wire or bi-amp an AV 5120, connect to the amplifier or amplifiers as shown in the illustration, using Linn K400 cable.

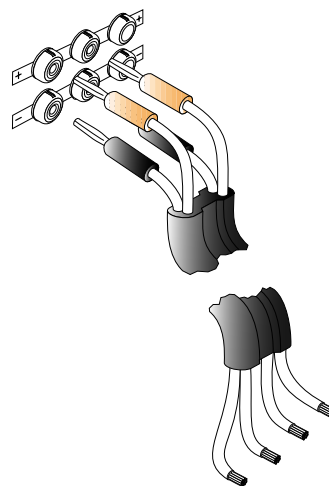



To bi-wire or bi-amp an AV 5140 install the linking plates so that they connect just the lower two terminals on each side, and connect the amplifier to the upper two terminals on each side as shown in the illustration, using Linn K400 cable.

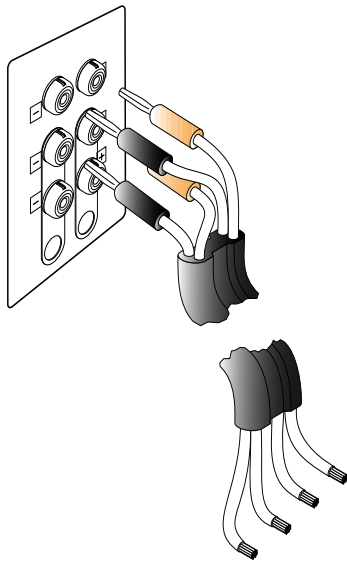

### **Tri-wiring or tri-amping**

To tri-wire or tri-amp an AV 5140 connect to the amplifier with three pairs of connectors, using Linn K600 cable.

## Removing the grilles and cleaning the loudspeakers

The grilles can be removed from the AV 5140 or AV 5120 loudspeakers if you do not need the protection they provide, and prefer the appearance of the loudspeakers without them.

### Remove the grille from the AV 5140 or AV 5120 midrange driver like this

Pry out the rubber trim ring.

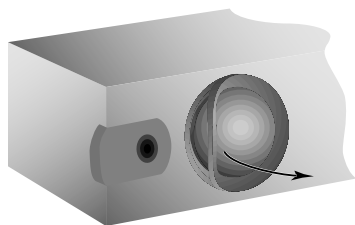

Then remove the perforated steel grille.

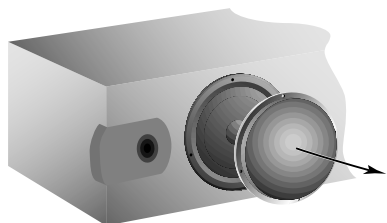

Finally, replace the trim ring, locating the lugs in the slot around the inside of the rim.

### Clean the loudspeakers like this

Use a soft, damp cloth; this will remove any dirt deposits without damaging the cabinets.

# setting up the AV 5110

---

## Unpacking

Each pair of AV 5110 loudspeakers comes in a box with the following accessories:

- Four rubber feet.
- A manual.
- Badge.

We recommend you retain the packaging in case you need to transport the loudspeakers at a later date.

## Positioning AV 5110 loudspeakers

The fully screened drive units allow you to place the AV 5110 in virtually any location, without the risk of magnetic interference, making it ideal for use in an AV system or with a multimedia PC. Its small size and excellent performance also makes it perfect for most multi-room or communications applications. In addition, its durable, weather resistant, flame retardant and UV stable cabinet ensures that the AV 5110 is suitable for many professional, commercial and industrial applications.

The AV 5110 is easy to accommodate either free standing, mounted on stands, or wall-mounted using Linn BRAKITs for omni-directional orientation (Linn part number: BRAKIT/1).

Note that the AV 5110 is weather resistant but not waterproof, so should not be left outdoors.

### Wall mounting

You can mount AV 5110 loudspeakers on the wall with Linn BRAKITS, which are available separately from your Linn dealer. They provide an extremely secure and rigid fixing to the wall, and allow you adjust the angle of each loudspeaker to point it towards the listening position.

First prise off the cover moulding on the rear of the loudspeaker using a screwdriver. Ease off one side at a time, and remove the cover from the rear of the loudspeaker.

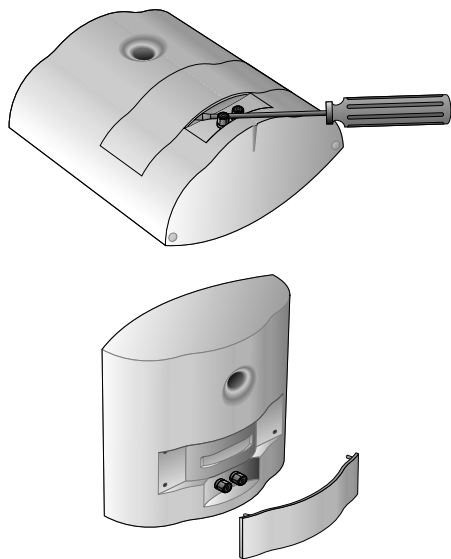

Then fit the BRAKIT with the 4 self tapping screws supplied with the BRAKIT.

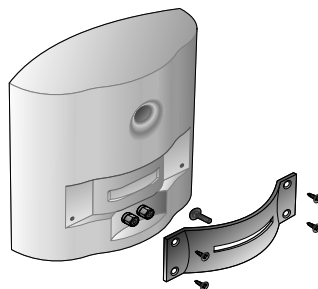

Mount the other half of the BRAKIT to the wall, and join the two sections of the BRAKIT together with the nut and bolt supplied, using the spanner supplied in the BRAKIT kit.

For optimum sound quality the AV 5110 loudspeakers should be mounted so that they are at head height when you are sitting down listening to music. Alternatively you may prefer to mount them at picture height so that they fit in with other features of your room, or in a corner or cornice.

### Removing the grilles

The grille can be removed from the AV 5110 for painting.

Use a sharp pin or paper clip to prise the grille out, and remove the anti-vibration mat.

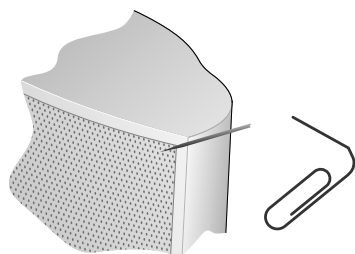

Replace the anti-vibration mat, and refit the grille by pressing it carefully back into position, taking care not to bend it.

### Painting the AV 5110

The AV 5110 loudspeaker can be painted, if you want to match it to the colour of your wall. You can use any non solvent based paint, and suitable paints are acrylic and emulsion paints. We recommend that you spray paint it to avoid leaving brush strokes.

Before painting the loudspeaker you should remove the grille as described in *Removing the grilles*, above. Mask the middle section of the speaker, which is concealed by the grille, and the input terminals. You can now paint the cabinet and the grille. Leave the AV 5110 and grille to dry, as recommended in the paint manufacturer's instructions. Then remove the masking and refit the grille.

## Connecting the AV 5110

### Bare wires

The sockets are designed so you can connect to them using either plugs or bare wires. To use bare wire connections undo the terminal collar, and insert the wires through the holes in the pillars making sure they do not touch. Then tighten the terminal collars to secure the wires.

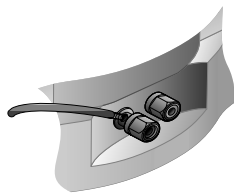

# setting up the AV 5150

---

## Unpacking

Each AV 5150 loudspeaker comes in a box with the following accessories:

- Phono-to-phono lead.
- Mains lead.
- Four spikes, nuts and washers.
- Four casters.
- This manual.
- Linn badge.
- Two fuses.

We recommend you retain the packaging in case you need to transport the loudspeakers at a later date.

**WARNING: The AV 5150 loudspeaker weighs 46kg (101lb). Do not attempt to lift it unaided.**

## Positioning

The AV 5150 operates over the frequency range from 15Hz to 100Hz. In theory, because the wavelengths associated with this frequency range (20m to 3m) are so large, the positioning of the AV 5150 with respect to the other speakers in the system should not be critical. However, for the best music reproduction keep the AV 5150 within a few meters of the main system speakers. This is especially true if the AV 5150 is set to operate up to its maximum bandwidth, or if it is being used with very small main speakers.

The versatile design of the AV 5150 allows it to be used either horizontally or vertically, for floor-standing, rack, or video-wall mounting.

### Fitting the casters

The AV 5150 is supplied with casters, which you can fit to make it easier to move the loudspeaker.

Screw each caster into the recessed threaded hole in each corner of the base of the loudspeaker.

### Fitting spikes

If you are positioning the loudspeaker on a carpeted floor we recommend you fit the spikes supplied with the loudspeaker, as these will penetrate the pile of the carpet and avoid damaging the carpet, while also giving a more stable performance.

Fit the spike boss using the M8 cap screw and washer provided.

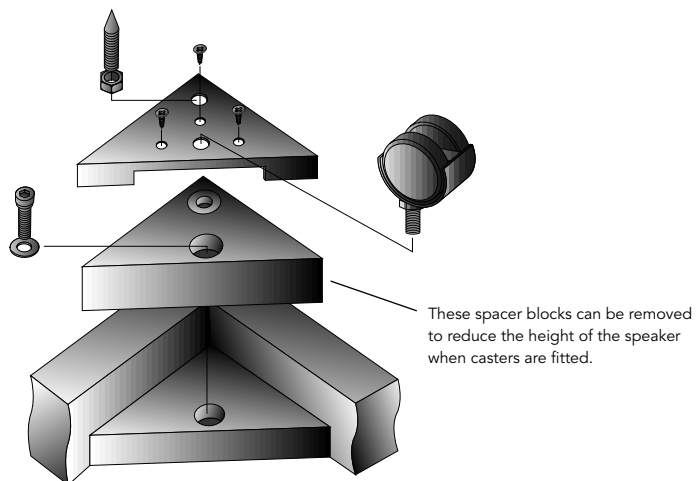

Then fit the spike and M8 nut and adjust until the spike is secure. Finally tighten the locking nut until it is hand-tight.

If you have wooden or solid floors you should use the spikes in conjunction with Linn SKEETS, to provide a firm base and protect the floor from scratches. These are available from your Linn dealer.

### Hiding the cables

For neat installation the cables can be passed under the base and up through a hole to exit at the relevant sockets.



## Removing the base

The AV 5150 can be installed on its side in a partition wall, or behind a screen. If you do this ensure there is adequate ventilation around the heat sink at the front of the unit.

Lie the speaker on its side with the heatsink uppermost. R

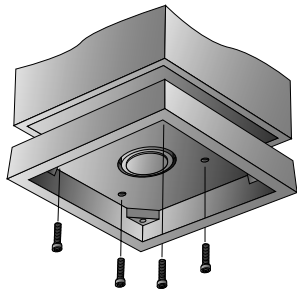

Remove the base by unscrewing the four M8 cap screws, lift off the base, and remove the grilles and stand offs.

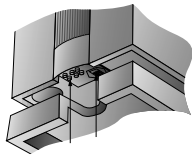

## Connecting the AV 5150 Active Isobarik Bass Speaker

The following diagram shows the connections to the AV 5150:

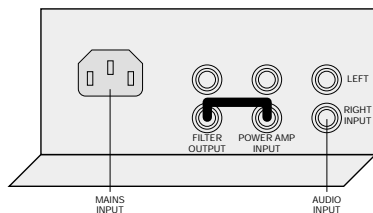

### Connecting the mains supply

Connect the mains supply to the loudspeaker using the mains lead provided.

When you first apply power to the AV 5150 it switches on, as shown by a green indicator on the front panel.

After ten minutes of inactivity the AV 5150 automatically switches to standby, and the indicator changes to red.

The AV 5150 automatically switches on from standby when it senses a signal on the input.

### Connecting the AV 5150 to a stereo preamplifier

Connect the left and right inputs of the AV 5150 to the left and right line outputs of the preamplifier, which already feed the main system power amplifier. The left and right signals are added inside the AV 5150 without affecting the left and right signals to the main system power amplifier.

### Connecting to the AV 5103 System Controller

Connect the AV 5150 phono socket marked RIGHT INPUT to the SUB output on the AV 5103, using the phono lead provided.

### Using more than one AV 5150

To use more than one AV 5150 in a system connect the DAISY OUTPUT from the first AV 5150 to the DAISY INPUT on the next AV 5150, using a phono lead. This takes the filtered output from the first loudspeaker to the direct input of the next loudspeaker, without further filtering. The soft clipper and phase response can be adjusted independently on each loudspeaker; see *Protecting the Speaker*, page 29, and *Inverting the phase response*, page 29.

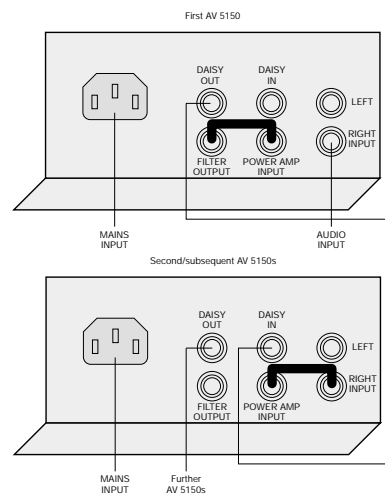

To enable the remote sense on the second AV 5150 in the daisy chain, remove the link between the FILTER OUTPUT and POWER AMP INPUT and add a link between the RIGHT INPUT and POWER AMP OUTPUT, as shown in the diagram opposite.

#### **Additional wiring to the AV 5150**

With some video sources there may be inadequate signal present on the subwoofer output of the surround processor to switch on the AV 5150. This manifests itself by the AV 5150 repeatedly switching to standby, for example during long periods of dialogue. To prevent this happening take a second feed from the centre channel output of the surround processor and connect it to the left input of the AV 5150. This will trigger the signal detection circuitry from either subwoofer signal or centre channel signal.

## Adjusting the AV 5150

The key parameters of the AV 5150 can be adjusted to suit the room, and the system with which it is used, using the switches which can be accessed by removing the panel.

### Removing the panel

The AV 5150 gain control and option switches are protected by a metal panel, which is located on four pins. To remove the panel pull it gently outwards.

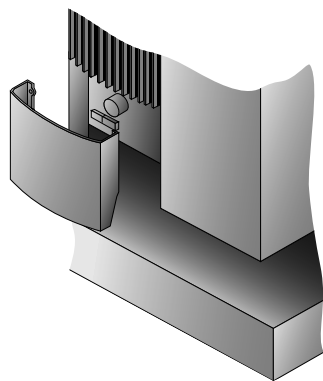

To refit the panel line up the four pins on the metalwork with the four mounting bushes on the door, and push it firmly back into place.

### Adjusting the frequency response

The upper frequency response of the AV 5150 (low pass filter) is set by the left-hand bank of switches. The low pass filter should be set to complement the low frequency response of the main speaker system. Very small main speakers will need the AV 5150 to respond to higher frequencies than large main speakers.

Set the switches as follows, where a switch is shown in black:

Response	Setting																
41Hz	<table border="1"> <tr><td>1</td><td>2</td><td>3</td><td>4</td><td>5</td><td>6</td><td>7</td><td>8</td></tr> <tr><td>■</td><td>■</td><td>■</td><td>■</td><td>■</td><td>■</td><td>■</td><td>■</td></tr> </table>	1	2	3	4	5	6	7	8	■	■	■	■	■	■	■	■
1	2	3	4	5	6	7	8										
■	■	■	■	■	■	■	■										
45Hz	<table border="1"> <tr><td>1</td><td>2</td><td>3</td><td>4</td><td>5</td><td>6</td><td>7</td><td>8</td></tr> <tr><td>■</td><td>■</td><td>■</td><td>■</td><td>■</td><td>■</td><td>■</td><td>■</td></tr> </table>	1	2	3	4	5	6	7	8	■	■	■	■	■	■	■	■
1	2	3	4	5	6	7	8										
■	■	■	■	■	■	■	■										
48Hz	<table border="1"> <tr><td>1</td><td>2</td><td>3</td><td>4</td><td>5</td><td>6</td><td>7</td><td>8</td></tr> <tr><td>■</td><td>■</td><td>■</td><td>■</td><td>■</td><td>■</td><td>■</td><td>■</td></tr> </table>	1	2	3	4	5	6	7	8	■	■	■	■	■	■	■	■
1	2	3	4	5	6	7	8										
■	■	■	■	■	■	■	■										
54Hz	<table border="1"> <tr><td>1</td><td>2</td><td>3</td><td>4</td><td>5</td><td>6</td><td>7</td><td>8</td></tr> <tr><td>■</td><td>■</td><td>■</td><td>■</td><td>■</td><td>■</td><td>■</td><td>■</td></tr> </table>	1	2	3	4	5	6	7	8	■	■	■	■	■	■	■	■
1	2	3	4	5	6	7	8										
■	■	■	■	■	■	■	■										
58Hz	<table border="1"> <tr><td>1</td><td>2</td><td>3</td><td>4</td><td>5</td><td>6</td><td>7</td><td>8</td></tr> <tr><td>■</td><td>■</td><td>■</td><td>■</td><td>■</td><td>■</td><td>■</td><td>■</td></tr> </table>	1	2	3	4	5	6	7	8	■	■	■	■	■	■	■	■
1	2	3	4	5	6	7	8										
■	■	■	■	■	■	■	■										
67Hz	<table border="1"> <tr><td>1</td><td>2</td><td>3</td><td>4</td><td>5</td><td>6</td><td>7</td><td>8</td></tr> <tr><td>■</td><td>■</td><td>■</td><td>■</td><td>■</td><td>■</td><td>■</td><td>■</td></tr> </table>	1	2	3	4	5	6	7	8	■	■	■	■	■	■	■	■
1	2	3	4	5	6	7	8										
■	■	■	■	■	■	■	■										
69Hz	<table border="1"> <tr><td>1</td><td>2</td><td>3</td><td>4</td><td>5</td><td>6</td><td>7</td><td>8</td></tr> <tr><td>■</td><td>■</td><td>■</td><td>■</td><td>■</td><td>■</td><td>■</td><td>■</td></tr> </table>	1	2	3	4	5	6	7	8	■	■	■	■	■	■	■	■
1	2	3	4	5	6	7	8										
■	■	■	■	■	■	■	■										
74Hz	<table border="1"> <tr><td>1</td><td>2</td><td>3</td><td>4</td><td>5</td><td>6</td><td>7</td><td>8</td></tr> <tr><td>■</td><td>■</td><td>■</td><td>■</td><td>■</td><td>■</td><td>■</td><td>■</td></tr> </table>	1	2	3	4	5	6	7	8	■	■	■	■	■	■	■	■
1	2	3	4	5	6	7	8										
■	■	■	■	■	■	■	■										
79Hz	<table border="1"> <tr><td>1</td><td>2</td><td>3</td><td>4</td><td>5</td><td>6</td><td>7</td><td>8</td></tr> <tr><td>■</td><td>■</td><td>■</td><td>■</td><td>■</td><td>■</td><td>■</td><td>■</td></tr> </table>	1	2	3	4	5	6	7	8	■	■	■	■	■	■	■	■
1	2	3	4	5	6	7	8										
■	■	■	■	■	■	■	■										

### Adjusting the output impedance

The four switches of the right-hand bank control the power amplifier output impedance, to increase or reduce the damping of the loudspeaker drive units. A larger room will often require more bass damping.

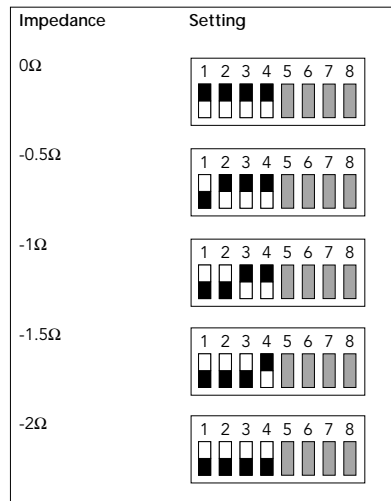

Note that decreasing the impedance increases the damping.

### Protecting the speaker

Switch 6 brings a soft clipper into the bass circuit path. Use this if you frequently play the system very loud. It allows very impressive sound effects while protecting the drive units against extreme overdrive.

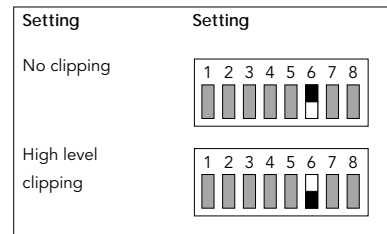

### Inverting the phase response

Switch 7 inverts the phase response. Use this if the main system power amplifier or speakers are inverting. It may also give better results if the 5150 is at the opposite end of the room from the main speakers.

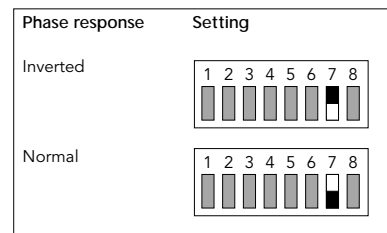

### Varying the gain

Switch 8 allows the gain to be varied with the control above the switches, or bypassed if the preamp has a variable bass output level. Use this to set the bass level for the system. Don't be tempted to turn it up until it hurts! Leave it fairly subtle. It is easy for the bass level to become overpowering.

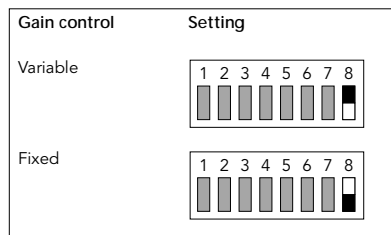

## guarantee and service

---

This product is guaranteed under the conditions which apply in the country of purchase.

To help us, please ask your retailer about the Linn warranty scheme in operation in your country.

In Europe, America and other markets, extended warranty is offered to customers who register their purchase with Linn. A Registration Card can be obtained from your retailer and should be stamped by him. This will also enable you to receive the Linn RECORD Newsletter and details of music available from Linn.

### **Warning**

Refer all enquiries to authorised dealers only. Unauthorised servicing or dismantling of the product invalidates the manufacturer's warranty.

For full warranty details, please refer to the card enclosed.

If you are in any doubt, please contact your nearest Linn dealer. For information on your nearest Linn dealer, contact the Linn factory in Scotland or your national distributor.

### **Important**

Please keep a copy of the sales receipt to establish the purchase date of the product.

Please ensure that your equipment is insured by you during any transit or shipment for repair.

LINN PRODUCTS LTD., FLOORS ROAD, WATERFOOT, EAGLESHAM,  
GLASGOW G76 0EP, SCOTLAND, U.K.

TELEPHONE: ++44 (0)141 307 7777

FACSIMILIE: ++44 (0)141 644 4262

E-MAIL: [helpline@linn.co.uk](mailto:helpline@linn.co.uk)

INTERNET: <http://www.linn.co.uk/linn>

CUSTOMER SERVICES, U.K.: FREECALL 0500 888 909

CUSTOMER SERVICES, GERMANY: FREECALL 0130 82 21 56

CUSTOMER SERVICES, U.S.A.: TOLLFREE 888-671-LINN

## technical information

---

### AV 5140 Front Loudspeaker

Volume	42 litres.
Frequency response	30Hz to 20KHz $\pm$ 3dB.
Input impedance	4 $\Omega$ .
Amplifier power	Minimum: 60W into 4 $\Omega$ .
Efficiency	90dB for 1W at 1m (1KHz).
Magnetic screening	Within 3 gauss.
Crossover options	Treble level can be reduced by 1dB on the crossover board.
Wiring options	Single-wiring, bi-wiring, tri-wiring, bi-amplification, and tri-amplification.
Size	980mm x 235mm (rear) x 320mm (38" x 9" x 12") (H x W x D).
Weight	21.5Kg (47lb) each.
Finishes	Black Ash or American Cherry.

### AV 5120 Compact Loudspeaker

Volume	14.5 litres.
Frequency response	55Hz to 20KHz $\pm$ 3dB.
Input impedance	4 $\Omega$ .
Amplifier power	Minimum: 60W into 4W.
Efficiency	90dB for 1W at 1m (1KHz).
Magnetic screening	Fully screened within 3 gauss from the cabinet edge.
Crossover options	Treble level can be reduced by 1dB on the crossover board.
Wiring options	Single-wiring, bi-wiring, and bi-amplification.
Size	614mm x 170mm x 248mm (24.2" x 6.7" x 9.8") (H x W x D).
Weight	10.6kg (23.4lb).
Finishes	Black Ash or American Cherry.



## AV 5110 Local Loudspeaker

Type	2-way bass reflex loudspeaker.
Frequency response	80Hz to 20KHz $\pm$ 3dB.
Input impedance	4 $\Omega$ .
Amplifier power	Minimum: 20W into 4 $\Omega$ .
Efficiency	88dB for 1W at 1m (1KHz).
Drive units	10mm polymer domed treble unit, 100mm diecast chassis bass/midrange, shielded.
Magnetic screening	Fully screened within 3 gauss from the cabinet edge.
Applications	Full range speaker suitable for hi-fi, AV front, centre, or rear. Free standing or wall mounted using Linn Brakit.
Size	228mm x 235mm x 103mm (9.0" x 9.3" x 4.0") (H x W x D).
Weight	2.7kg (6.0lb).
Finishes	Sparkle Black or Sparkle White.

## AV 5150 Active Isobarik Bass Speaker

Type	Active Isobarik bass reflex loudspeaker.
Frequency response	15Hz to 100Hz $\pm$ 3dB.
Input impedance	5K $\Omega$ .
Amplifier power	200W built in amplifier.
Drive units	Two 305.0mm (12") polypropylene cone bass drivers.
Applications	Hi-fi sub bass, AV sub bass.
Size	483mm x 640mm x 483mm (19" x 25" x 19") (H x W x D).
Weight	46kg (101lb) each.
Finishes	Black Ash or American Cherry.

# index

---

<b>a</b>	<b>AV 5101 Personal</b>	
	Handset . . . . .	2
	<b>AV 5103 System</b>	
	Controller . . . . .	1
	<b>AV 5105 Stereo Power</b>	
	Amplifier . . . . .	2, 6
	<b>AV 5110 Local</b>	
	<b>Loudspeaker . . . . .</b>	<b>4</b>
	connecting . . . . .	22
	painting . . . . .	21
	positioning . . . . .	19
	setting up . . . . .	19
	technical information . . . . .	33
	unpacking . . . . .	19
	using . . . . .	10
	wall mounting . . . . .	20
	<b>AV 5120 Compact</b>	
	<b>Loudspeaker . . . . .</b>	<b>3</b>
	using as main	
	loudspeakers . . . . .	7
	cleaning . . . . .	18
	connecting . . . . .	15
	positioning above or below	
	a television . . . . .	13
	removing linking plates . . . . .	15
	removing the grilles . . . . .	18
	setting up . . . . .	11
	unpacking . . . . .	11
	technical information . . . . .	32
	using a pair as main	
	loudspeakers . . . . .	7

<b>AV 5120 Compact</b>	
<b>Loudspeaker (continued)</b>	
using as a centre speaker . . . . .	13
using as main	
loudspeakers . . . . .	13
wall mounting . . . . .	14
<b>AV 5140 Floor-Standing</b>	
<b>Loudspeakers . . . . .</b>	<b>3</b>
adjusting the feet . . . . .	12
cleaning . . . . .	18
connecting . . . . .	15
fitting the bases . . . . .	12
positioning near a rear	
wall . . . . .	11
positioning near a	
television . . . . .	12
removing linking plates . . . . .	15
removing the grilles . . . . .	18
setting up . . . . .	11
technical information . . . . .	32
unpacking . . . . .	11
using floor-standing as rear	
surrounds . . . . .	8
using as front	
loudspeakers . . . . .	7
using with a centre	
loudspeaker . . . . .	12

<b>AV 5150 Active Isobarik Bass</b>	
<b>Speaker . . . . .</b>	<b>4</b>
additional wiring . . . . .	27
adjusting the frequency	
response . . . . .	28
adjusting the output	
impedance . . . . .	29
connecting to a stereo	
preamplifier . . . . .	26
connecting to the AV 5103	
System Controller . . . . .	26
fitting spikes . . . . .	23
fitting the casters . . . . .	23
inverting the phase	
response . . . . .	29
positioning . . . . .	23
protecting . . . . .	29
removing the base . . . . .	25
removing the panel . . . . .	28
setting up . . . . .	23
technical information . . . . .	33
unpacking . . . . .	23
using . . . . .	9
using more than one . . . . .	26
varying the gain . . . . .	30

<b>b</b>	<b>bare wires . . . . .</b>	<b>22</b>
	<b>bases, fitting . . . . .</b>	<b>12</b>
	<b>bi-amping . . . . .</b>	<b>16</b>
	<b>bi-wiring . . . . .</b>	<b>16</b>

<b>c</b>	cables, hiding . . . . .	24
	casters, fitting . . . . .	23
	cleaning . . . . .	18
	connecting, using bare wires . . . . .	15
	corner, spacing . . . . .	11
<b>f</b>	feet	
	adjusting . . . . .	12
	fitting . . . . .	13, 14
<b>g</b>	gain, varying . . . . .	30
	grilles, removing . . . .	18, 21
	guarantee . . . . .	31
<b>i</b>	introduction . . . . .	1
<b>k</b>	K20 cable . . . . .	16
	K400 cable . . . . .	17
	K600 cable . . . . .	17

<b>l</b>	linking plates, removing . .	15
	Linn AV System . . . . .	1
<b>m</b>	mounting with a BRAKIT . .	14
<b>p</b>	phase response, inverting .	29
	projection screen . . . . .	13
<b>r</b>	rear wall, spacing . . . . .	11
	rubber feet, fitting . . . .	13, 14
<b>s</b>	service . . . . .	31
	single-wiring . . . . .	16
	spikes, fitting . . . . .	23
<b>t</b>	technical information	
	AV 5110 Local Loudspeaker . . . . .	33
	AV 5120 Compact Loudspeaker . . . . .	32

**technical information**  
*(continued)*

	AV 5140 Front Loudspeaker . . . . .	32
	AV 5150 Active Isobarik Bass Speaker . . . . .	33
	<b>terminal key . . . . .</b>	<b>11</b>
	<b>tri-amping . . . . .</b>	<b>17</b>
	<b>tri-wiring . . . . .</b>	<b>17</b>

<b>u</b>	unpacking . . . . .	11, 19, 23
<b>w</b>	wall mounting . . . . .	14, 20

