

RULES FOR SAFE OPERATION OF GRASS/WEED TRIMMERS**WARNING****DANGER**

- Grass/Weed Trimmers can be dangerous and can cause serious injury if improperly used. Operators, helpers and bystanders can be severely injured by thrown objects.

Operators, helpers and bystanders within a 33 foot (10 meter) radius of the operating trimmer must wear eye protection that meets ANSI 287.1 requirements (287 is stamped on the goggles).

Failure to wear approved eye protection can result in eye loss or blindness. **DO NOT** rely on cutterhead shield to protect eyes. Ricochet can occur.

- To avoid accidental contact, keep all people and animals outside the 33 foot, (10 meter) radius.
- To reduce the risk of injury to operator, helpers and bystanders read and understand the Operators Manual and Safety Manual that you received with your Grass/Weed trimmer. For a free copy of the ECHO Grass/Weed trimmer, Burshcutter and Clearing Saw Safety Manual write to ECHO, INCORPORATED, 400 Oakwood Road, Lake Zurich, IL 60047.
- Keep shield and other components in place and in good condition.
 1. Read the Operator's Manual carefully. Be thoroughly familiar with the controls and proper use of the trimmer. Know how to stop the unit and disengage the controls.
 2. Never allow children to operate the trimmer.
 3. Never allow adults to use the trimmer unless they have received proper instructions. Be sure the operator is properly attired and wears the type of foot, leg, head, eye and ear protection recommended both in your ECHO Operator's Manual and by your ECHO Servicing Dealer.

OPERATION

The ECHO Automatic Head advances line automatically as the line wears. The automatic head operates best while rotating at a speed of 4800-6000 RPM (half to full throttle). The head will not advance line if operated below 4800 RPM.

NOTE 1: The head comes assembled with red springs in the hub providing correct calibration for most ECHO Trimmers. Additional silver and yellow spring sets are included for assembly into the hub for specific ECHO model and year trimmers. Refer to the following tables for automatic head spring calibration and trimmer application.

Part Number	Description	Model Application
696221 52130	Spring Set, RED	SRM-200, 200AE, 200BE, 200CE, 200D, 200DA, 200F, 202FA, 250E, 1500, 1500A, 1501, 2200, 2201, 2300, 2301, 2310, 2400, 2501, 2510
696221 51730	Spring Set, SILVER	SRM-3000 (1986), -3001 (1987-1990)
696221 51830	Spring Set, YELLOW	SRM-3000 (1991)

NOTE 2: When this head is installed on an ECHO Trimmer other than SRM-3000 series be sure to mount the cut off knife in the plastic shield holes closest to the gear housing, with the knife towards the outside of the shield. This will provide a cutting swath of 16 inches. When installing the head onto any SRM--3000 series trimmer, position the cutoff knife in the outside holes with the knife towards the outside of the shield. This will provide a cutting swath of 17 inches.

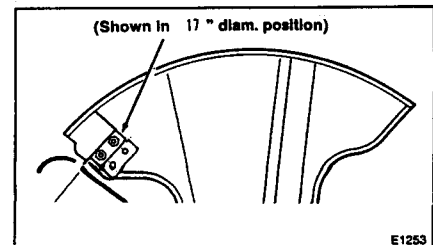
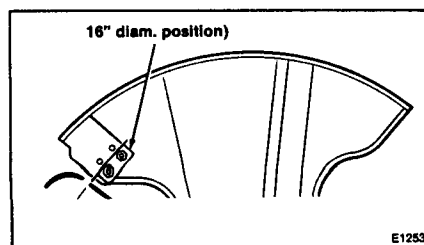

REPLACING NYLON LINE

1. Turn bottom knob clockwise to loosen and remove knob, bottom cap and line spool.

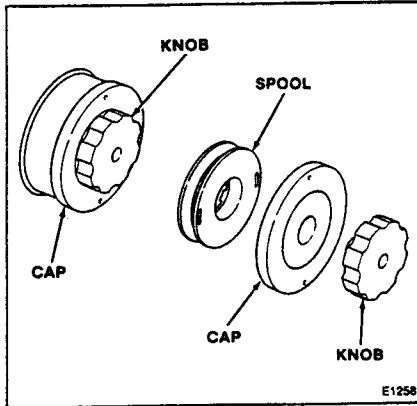

2. Use one line (20 feet x .095" dia.) and bend in half with one half 6" longer.
3. Hook the bend into the notched center portion of the spool.

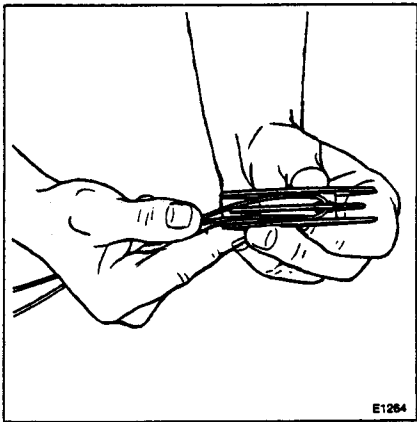

4. Wind the line on the spool tightly and evenly in a counterclockwise direction, (when viewing the spool from the bottom).

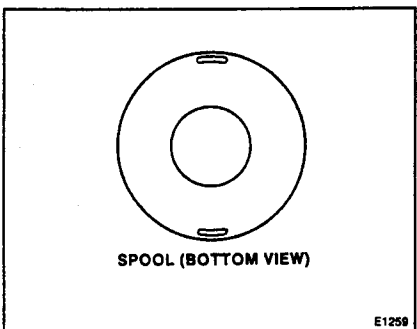
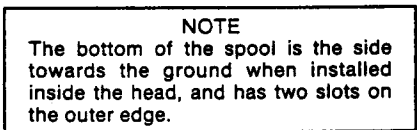

5. Wrap the line to within 4-6 inches of the ends. Pull a loop from each line up into the notches located on the outer rim of the spool. This will hold the line in place during reassembly into the head.

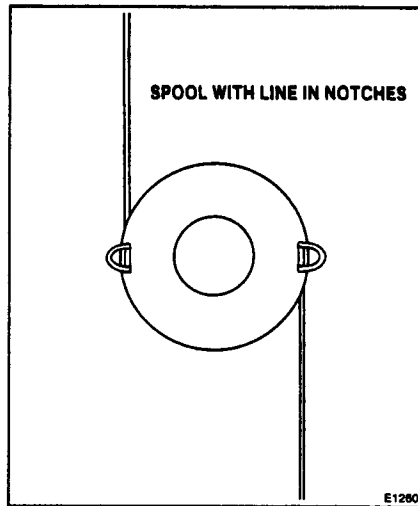

6. Assemble spool into head aligning notches with cams on white plate.
7. Assemble cap onto head aligning outer holes over eyelets. Seat the cap securely in place. Tighten knob in counterclockwise direction.
8. Pull both lines to disengage from notches in spool.
9. Cut lines to 6".

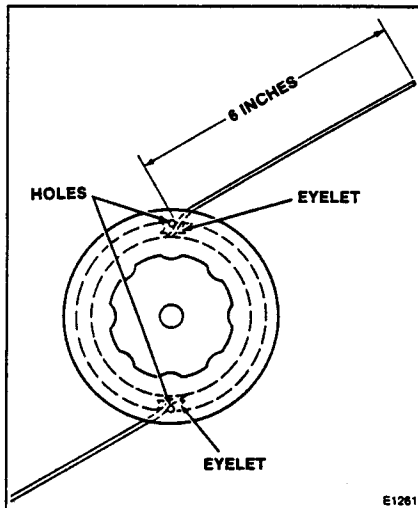

REPLACING CALIBRATED SPRINGS

10. Follow step 1.
11. Press eyelets from hub outside to inside.
12. Insert special spanner tool into the flat nut holding the cam plate in place and turn clockwise to loosen and remove. Remove cam plate and center adapter bolt.

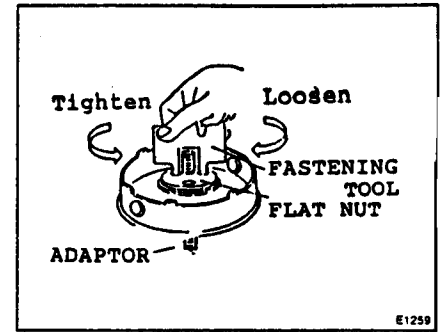

13. Remove and replace springs.

NOTE: When reassembling lugs and springs into the hub slots first install the spring into the lug then assemble lug and spring into hub slot. The spring end always rests against the outer hub wall.

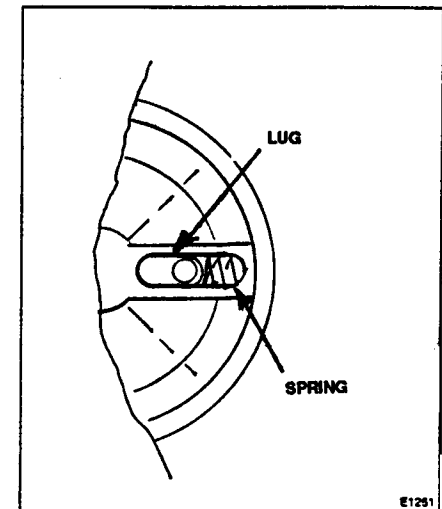

14. Reassemble center adaptor bolt, cam plate, nut and eyelets in reverse order.
15. Reassemble line spool and remaining components following steps 6-9.