

c3/4-43



Canon
INTERCHANGEABLE LENSES
FD

INSTRUCTIONS

English Edition

Canon Interchangeable Lenses, FD Series

The Canon F-1 has adopted the full aperture metering system which boasts an accuracy equal to, if not better than, the stopped-down metering system employed in the Canon FT. It incorporates a transmitting mechanism for aperture signals in the lens and camera body. In order to expand the F-1 system, Canon's Optical Department, making full use of electronic computers, developed a series of high performance interchangeable lenses of the highest quality. The newly designed lenses boast high quality and preeminent performance. The FD series of lenses also include special lenses. In the wide-angle lens series, lenses for every 10 degrees in

angle of view were produced, while in the telephoto range, lenses for every 100mm in focal length were provided to greatly strengthen the photographic range. Besides these, aspherical lenses, fluorite lenses, and fish-eye lenses were developed. Furthermore, the use of multi-layer antireflection optical coatings and the adoption of Canon's unique focusing mechanism have contributed to the strengthening of the FD series. This new group of lenses can be used not only for the Canon F-1, EF, FTb, TLb but also for the Canon FT, Pellix and models with R lenses.

FD Lens and Mount

The mount for FD lenses is that which was first marketed in 1959 for the Canonflex. Its easy-to-attach features, interchangeability with each lens, and its durability satisfy all requirements. The following are its features:

1. Interchangeability

Not only the FD series of lenses but also the FL and R lens groups and all accessories can be used on this mount.

2. Speedy Changing

Changing time is much less than the screw-in or bayonet mount types. For example, this mount can be changed in one-third the time required for changing a screw-in type mount.

Changing operations are very easy even when interchanging large aperture or telephoto lenses.

3. Durability

Durability is guaranteed because brass is used on both the lens and camera body sides. The mount has superior corrosion-proof and aberration-proof qualities because hard chrome plating is applied over nickel plating. The standard surface of the mount, which affects focusing, is just closely attached without a rubbing motion to prevent scratches.

For F-1, EF, FTb and TLb Use

FD Lenses: Full aperture metering. Coupled to automatic aperture.

FL Lenses: Stopped-down metering. Coupled to automatic aperture.

R Lenses: Stopped-down metering. Manually operated aperture.

■ FD lenses are used on the Canon FT, Pellix and FX cameras for stopped-down metering coupled to automatic aperture, and used with manually operated aperture when attached to R series of camera bodies.

Effects of Interchanging Lenses

1. Change In Angle of View and Perspective

Photographic differences according to different kinds of lenses used, is mostly due to the differences in focal lengths. Generally, this is understood as changes in angle of view or differences in perspective.

When the focal length of a lens becomes longer the image becomes larger. Since the size of the film is fixed, this is indicated by angle, and we say that an angle of view range of so many degrees is photographed.

Just as it is when a subject is seen with the naked eye, the closer the lens gets to the subject, the larger becomes the photographed



28 mm



50 mm



200 mm

result, and distant subjects are photographed in small sizes. Therefore, changes in angle of view are compared with pictures taken of the same subject from the same position.

When photographing from the same position with different focal length lenses, there is no difference in perspective between a wide-angle and telephoto lens. However, if the photographing distance is changed, the perspective changes even when using the

same lens. In this case, however, since the angle of view of the lens is the same, the necessary subject is sometimes cut off or the degree of the blurred background changes. (When this difference in perspective by photographic distance is substituted by a lens of a different focal length, it is called perspective.)

In the case of perspective, the size of the main subject is fixed. Then this same subject



28 mm



50 mm



200 mm

is photographed using different lenses and by changing the photographing distance so that the size of the subject remains the same. In this way it is possible to express the different distances between the main subject and the background.

This distance is exaggerated when a wide-angle lens is used and subdued when a telephoto lens is used.

2. Depth-of-Field

The blurred range changes when the focal length of a lens changes. The focusing range becomes smaller as the focal length becomes longer. The focusing range also changes when the lens speed changes. Therefore, the various lenses should be used after understanding the characteristic of lenses such as the size of the subject, perspective, degree of blurring, and lens speed.

Classification of Lenses

The angle of view of lenses changes according to focal lengths. In the case of 35mm cameras, the standard focal length is set at 50mm. Lenses with a shorter focal length are called wide-angle and those with a focal length longer than 50mm are called telephoto.

Wide-Angle Lenses

A wide angle of view is photographed when using this type of lens. Because lenses in this category have a deep depth of field, they are suited for taking snapshots, in taking photographs where there is no room to back up, for photographing large groups of people, and for taking pictures of buildings. A wide-angle

lens has the characteristic of exaggerating the perspective, but this can be used to advantage for taking pictures with a different effect.

The most commonly used wide-angle lens is the 35mm lens. Recently, however, the development of super-wide-angle lenses has become extensive, thereby rapidly expanding the range of photography.

(In the case of lenses for single-lens reflex cameras, the optical system is protruding forwards, when compared with the focal distance, because the optical back focus distance is long. For this reason, these lenses are called retrofocus type lenses.)

Standard Lenses

These lenses have a focal length of 50mm and have the widest applicable range. They are widely used not only for snapshots of scenery and people, but also to advantage in snapshots of night scenes due to their increasingly larger apertures. They are all-round lenses which also prove their high performance in close-up photography and copy work.

Telephoto Lenses

Lenses in this category have narrow angles of view in contrast to wide-angle lenses, but they have the feature of clearly delineating distant scenes. Therefore, they are advantageous for photographing difficult-to-approach subjects, mountains, sporting events, and news events. Telephoto lenses are also widely used for portraiture and commercial photography

because of their natural perspective. Generally, those lenses with focal lengths of 300mm or longer are called "super-telephoto".

- "Telephoto lens" is the name for those type of lenses, among long focal point lenses, in which the length of the lens is shorter than the focal length. Generally, however, no distinction is made.

Zoom Lenses

Zoom lenses are very convenient because a single zoom lens can be used instead of many interchangeable lenses by just changing its focal length.

Special Lenses

Fish-eye lens, tilt-and-shift lens and macro lens which are used for special kinds of photography are included in this category.



Uses of Lenses

Mounting Lenses

Remove the dust cap of the lens and then mount the lens onto the camera body.

- Turn the breech-lock ring in the direction of the arrow and remove the dust cap. For attaching, align the groove of the dust cap with the red dot on the breech-lock ring and then tighten the breech-lock ring.
- Align the red dot on breech-lock ring with the red dot on the lens attachment section of the camera body, mount the lens, and then turn the breech-lock ring clockwise for securely mounting the lens.
- A safety mechanism is incorporated which prevents the movements of the diaphragm blades and breech-lock ring when the lens is dismounted.



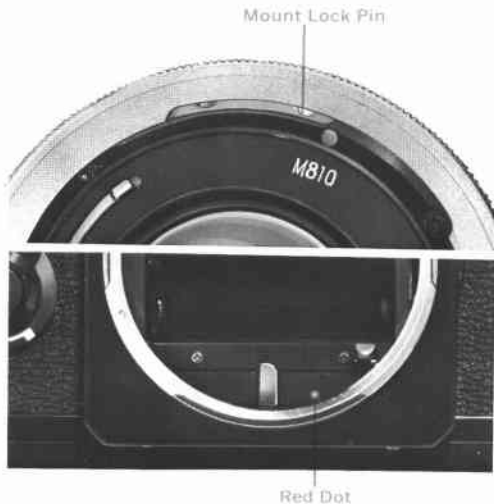

- In order to make the various mechanisms function, when the lens is dismantled, perform the following. Turn the breech-lock ring, so that it is in the same position as when the lens is in mounted condition, while pressing the mount lock pin with a small pointed object, like a pencil. The mount lock pin is situated below the breech-lock ring.
- Be sure to unlock the stopped-down functioning lever lock of the camera body. If the lever is pressed or is locked, the red dot, which indicates non-functioning can be seen inside the camera mount. The automatic/manual aperture lever, at the back end of the lens, cannot be connected to the coupling part on the camera body and the automatic aperture will not function.

Lens Signal Levers and Pins

1. Automatic/Manual Aperture Lever

This lever stops down the aperture to the preset position, and is of the same construction as that for the FL lenses. On all cameras after the Canon FX model, fully automatic aperture is performed with power drive from the camera. This lever is clamped when turned counterclockwise, and can be attached to R series cameras and used with manually operated aperture.

Note: Manually operated aperture is not necessary in the case of FT and Pellix cameras because stop-down can be performed with the metering lever. However, in the case of FX and R cameras, manually operated aperture is used in close-up photography and macro-photography when an accessory is used in

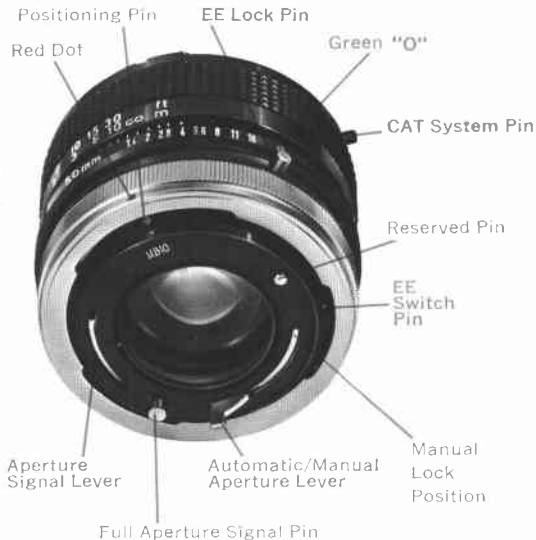

between the camera body and the lens and the automatic aperture lever is no longer coupled.

2. Aperture Signal Lever

This signal transmits the preset f/stop to the F-1 camera body. Power drive for the match needle for full aperture metering is operated by turning the preset aperture ring. It performs 1 to 1 movement with the preset aperture ring. On the other hand, when performing Servo EE photography, the preset aperture position is decided on the camera side by power drive on the Servo EE Finder side.

3. Full Aperture Signal Pin

This signal transmits the full opening f/stop of the lens. This pin is used for correcting the error of full aperture metering of the F-1 camera.

4. EE Lock Pin

A safety lock pin to prevent accidental movement over to the green "O." When setting to the green "O," turn the aperture ring while pressing the EE Lock Pin.

5. EE Switch Pin

This pin emits a signal when the preset aperture ring is set at the green "O" for EE use. When the lens aperture is set at this green mark, the lens can be attached only to the Canon F-1. If the lens is attached to the cameras other than the F-1, it cannot be set at the green mark.

6. Spare Signal Pin

Reserved pin for developing System Accessories for the F-1.

Aperture Operations

Automatic Aperture

In the case of FD lenses, the field-of-view through the viewfinder can always be observed at full aperture opening, even after the aperture ring has been set at the desired f/stop. The aperture is stopped down to the f/stop selected by the aperture ring only for an instant when the shutter is released. Immediately after the shutter has been released, the aperture again returns to full opening and a bright field-of-view.

Manually Operated Aperture

The manually operated aperture is used for observing what the focusing condition are actually like when the aperture stops down, and for special photography such as close-up and macrophotography.

An FD lens has only one aperture ring. However, when it is mounted on an F-1 or FTb, the diaphragm blades can be opened or closed by turning the aperture ring, after the stopped down metering lever on the front side of the camera body is pressed down and locked.

- When an accessory, such as an M tube with no aperture coupling pin, is to be inserted in between the lens and camera body, it can be set at manually operated aperture in the following manner. Before attaching the accessory, turn the automatic aperture lever to manual lock position and then attach the accessory onto the bayonet ring. For releasing the lock, push the automatic aperture lever to its former position.



- The manual aperture operations for the FD 50mm F 1.8 lens are different from those for other FD lenses. Move the aperture lever to the manual lock position and slide the manual lock lever to the "L" position. If mounted onto the camera in this condition, the lens aperture can be operated manually. This FD 50mm F 1.8 lens cannot be used on Canonflex R series of cameras.

Attaching Onto Macrophoto Coupler

When attaching a lens in the reverse position onto a macrophoto coupler and for obtaining a manually operated aperture condition, perform the following. First, move the automatic aperture lever over to the manual lock. Next, attach the Macrohood of the coupler and then turn the bayonet ring all the way. 15

Lens Aperture

Set the necessary f/stop at the index mark by turning the aperture ring. Amount of exposure and field-of-view adjustments are performed by this operation. In the case of F-1, proper exposures can be easily obtained by the TTL meter.

The aperture becomes darker as its f/stop gets larger. With each graduation increase, the amount of exposure decreases by one-half. When the aperture is stopped down by one graduation, the exposure time must be extended by two times. And when the aper-

ture is stopped down by two graduations, the exposure time must be extended by four times. Intermediate positions between graduations on the aperture scale can be used. FD lenses have click stops at intermediate positions between graduations on the aperture ring scale to facilitate operations. Some lenses have no relation to the one-half decrease in exposure volume between the maximum f/stop and the next f/stop. The ratio between the f/stops and amount of exposure, with f/2 as the standard, are as follows :

f/stops	1.2	1.4	1.8	2	2.5	2.8	3.5	4	5.6	8	11	16	22
exposure ratio:	3	2	1.25	1	1/2	1/3	1/4	1/8	1/16	1/32	1/64	1/128	



Distance Scale

The distance scale indicates the focused distance between the subject and the film plane. The scale is necessary for checking the depth-of-field, for flash and infrared photography.

■ The correct position of the scale is in the center of each value. For example, the correct position of a two-digit value is the center of the two figures.

Infrared Index Mark

For infrared photography, correction of the distance scale is necessary because the focal point slightly deviates from ordinary photography. Focus first in the ordinary manner, then adjust that focused distance to the red infrared index mark. For instance, if the



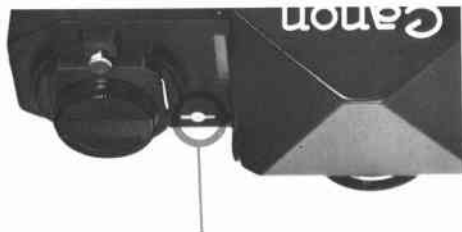

Film Plane Indicator

distance scale reads 10m after focusing, merely shift the 10 scale to the “ . ” position. The position of the “ . ” on the F-1 is based on using film with the highest wave-length sensitivity figure of $800\text{m}\mu$, such as Kodak IR 135 film with a Wratten 87 filter.

Film Plane Indicator

In case the focusing is done by actual measurement, measure the distance from the film plane indicator and interpret the measured distance on the distance scale.

Depth-of-Field Scale

The depth-of-field scale indicates the range of subjects which will be in focus sharply on the film. This range will vary with the following factors: The depth-of-field will be deeper the smaller the f /stop, the further the distance of the subject, and/or the shorter the lens focal length. The depth-of-field will be shallower the larger the f /stop, the nearer the distance of the subject, and/or the longer the lens focal length. For example, if the lens used is 50mm and the subject has been focused at a distance of 3m (10'), with an $f/8$ value read off from both indexes on either side of the focusing index mark, the depth-of-field is from approximately 2.3m (8') to 4.3m (14').

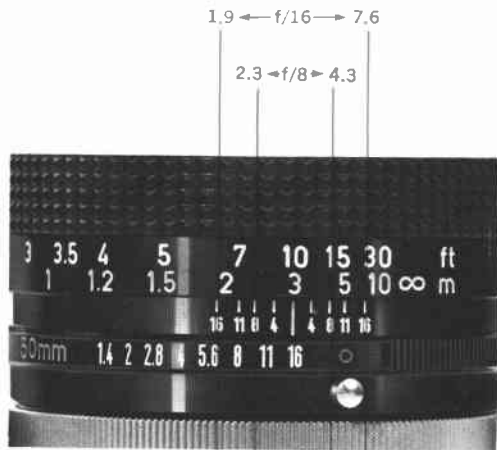

50mm Lens f/8

Depth-of-field 2.3-4.3m (8'-14')

Focused at 3m (10')



50mm Lens f/16

Depth-of-field 1.9-7.6m (6'-25')

Focused at 3m (10')



If the aperture is closed down to f/16, the picture will become sharp between 1.9m (6') to 7.6m (25') from the camera. This range will vary with the f/stop selected.

- In the case of Canon FD lenses, you can see the actual sharpness through the viewfinder by pressing the multi-purpose lever.
- Although air bubbles may sometimes be seen in a lens, they do not affect the resolution power or the sharpness of the picture.

FD Lens Mount (FL and R Series Lenses)

All Canon FD and FL lenses which have the FD and FL mounts can be used with the Canon F-1, except the FLP 38mm f/2.8.

- It is also possible to attach and use all the R lenses for Canonflex use. However, as the preset aperture mechanism differs, pictures must be taken by controlling the aperture manually.
- Attach the lens quickly in the shade. The film will sometimes become fogged if the lens is left unattached.
- Whenever a lens is removed, be sure to put on the dust cap to protect the various signal levers and pins.
- When not in use for a long time, protect the mirror with a flange cap.



CAT System Pin



CAT System Pin

The CAT System Pin is for automatic flash when using Canon Speedlite 133D. It is built into the four Canon FD lenses: 50mm f/1.4 S.S.C., FD 50mm f/1.8 S.C., FD 35mm f/2 S.S.C. and FD 35mm f/3.5 S.C.. When the Flash-Auto Ring is attached, it transmits the revolving degree of the focusing ring, in other words, the focused distance to the meter.

Therefore, the exposure can be decided inside the viewfinder, without guide number calculations, according to the match-needle system by turning aperture ring.

Canon FD Lenses



Special Lenses



**Canon Lens Fish-Eye 7.5mm
f/5.6 S.S.C.**



**Canon Lens Fish-Eye FD 15mm
f/2.8 S.S.C.**



**Canon Lens TS 35mm
f/2.8 S.S.C.**

This special type of lens covers an angle-of-view of 180° and takes pictures in the size of a 23mm diameter circle. It is not necessary to fix the mirror upward because this lens is of the retrofocus type. The unique images formed with this fisheye lens can be seen directly through the viewfinder when shooting.

This is a fisheye lens for ordinary photography. It covers an angle-of-view of 180° . Its lens speed of f/2.8 ranks among the fastest. This lens can be used without fixing the mirror upward because it is the retrofocus type. It can be used in the same manner as other ordinary FD lenses when metering and shooting. Sharp images can be obtained because this lens is treated with multi-layer coating.

It is indispensable for shooting distortion-free architectural photographs. Tilting and shifting can be performed individually or in combination. Shooting range and depth-of-field can be controlled. Diffused reflection has been eliminated with Canon's multilayer coating treatment technique. At the same time, Canon's Floating System was adopted to prevent image degradation in close-up photography.

Super Wide-Angle Lenses



**Canon Lens FD 17mm
f/4 S.S.C.**



**Canon Lens FD 20mm
f/2.8 S.S.C.**



**Canon Lens FD 24mm
f/2.8 S.S.C.**

Among the interchangeable lenses with short focal distance, this lens boasts perfect elimination of distortion. Instead of conventional retro-focus type lenses, this lens prevents aberration breakdowns between infinity and close distance because of changing its air distance of the lens system.

Despite its short focal length of 20mm, this super-wide-angle lens has the world's fastest lens speed of f/2.8. Canon's original and unique aberration compensation mechanism (Canon Floating System) was adopted in this lens in order to obtain sharp images throughout the entire close-up to infinity range.

This retro-focus type lens is noted for having a very fast lens speed for a super-wide-angle lens. It is combined with the full range aberration free system and it takes pride in its high contrast and high resolving power qualities even at full aperture opening.



**Canon Lens FD 28mm
f/3.5 S.C.**

It is a compact, lightweight lens but it guarantees clear and sharp pictures. Convenient wide-angle photography is possible with its 75-degree angle-of-view.

Wide-Angle Lenses



**Canon Lens FD 35mm
f/3.5 S.C.**

Compact, lightweight and highly efficient designed specially for taking snapshots. Its performance is indisputable and the elimination of the various aberrations is complete. It has high contrast and high resolving power. Even at full-aperture opening, it takes sharp images throughout the entire picture. Equipped with a coupling pin to Canon Auto Tuning (CAT) System.



**Canon Lens FD 35mm
f/2 S.S.C.**

As a wide-angle lens, it shows its superior efficiency when it is used for picture taking at full-aperture opening. Special emphasis is put into it so that it can be also used as standard lens. It incorporates the full range aberration-free system to assure high resolving power at a photographic distance of 30 centimeters. Equipped with a coupling pin to CAT System.

Standard Lenses



**Canon Lens FD 50mm
f/1.8 S.C.**



**Canon Lens FD 50mm
f/1.4 S.S.C.**



**Canon Lens FD 55mm
f/1.2 S.S.C.**

One outstanding feature of this lens is its superior angle-of-view characteristics from the middle to the outer edges and excellent effects. This standard lens has good delineation power even during close-up photography. Equipped with a coupling pin to CAT System.

The optical system of the reputed FL 50mm F 1.4 standard lens is put into effective use in this lens. Its high resolving power and high contrast delineation power are magnificent. Equipped with a coupling pin to CAT System.

It tops all the FD series of lenses for having the fastest lens speed. It is similar to but more advanced than the FD 50mm f/1.4 and despite its large aperture, it is highly regarded for its high contrast during full-aperture opening and for high resolving power.



**Canon Lens FD 55mm
f/1.2 AL S.S.C.**



**Canon Macro Lens FD 50mm
f/3.5 S.S.C.**

Despite its large $f/1.2$ aperture, spherical aberration and coma have been completely eliminated from this lens and flare has been held to a minimum. This lens provides superb image delineation power even at full aperture opening during night photography. This lens incorporates Canon's Floating System which performs aberration compensation during close-up photography.

Emphasis was laid on the resolving power of this lens at very close shooting distance. Close-up photography of up to $1:2$ is possible without any accessories. $1:1$ size photography is possible with the use of the life-size adapter. The exposure is automatically corrected. This lens is indispensable for close-up photography and copy work.

Telephoto Lenses



**Canon Lens FD 100mm
f/2.8 S.S.C.**

This telephoto lens is ideal for near natural snapshots and portrait photography. It is a fast speed lens which acquired the high performance of the FL 100mm $f/3.5$, regarded as the sharpest of all Canon telephoto lenses. Its telephoto ratio is very small and has an overall length of 57mm but high contrast and image-forming qualities are superb.



**Canon Lens FD 135mm
f/3.5 S.C.**



**Canon Lens FD 135mm
f/2.5 S.C.**



**Canon Lens FD 200mm
f/4 S.S.C.**

4 elements in 3 groups construction.
This is a high performance, small size, lightweight 135mm popular type lens. It is designed for taking sports pictures, portraits and mountain scenes.

Its usefulness is wide and perfect for portrait and commercial photography. This lens came out of the Canon factory as a result of improving the optical system of the FL 135mm f/2.5 lens. It has the fastest lens speed of the FD telephoto lenses.

This lens is an improved version of the conventional FL 200mm f/3.5 lens and one factor that makes it stand out is its length measuring only 13.3cm. Its high contrast and high resolving power are excellent. It's good for sports and news photography, portrait and snapshot photography and taking pictures of animal life.



**Canon Lens FD 300mm
f/5.6 S.C.**

This is a high performance, compact lens with a long focal length of 300mm. It is most convenient and advantageous for telephotography. Canon succeeded in developing it by using ordinary optical glass instead of the costly and special material, artificial fluorite. The telephoto ratio of this lens was shortened to 1:0.72 with the performance of a near perfect aberration correction.



Zoom Lenses



**Canon Zoom Lens
FD 100-200mm
f/5.6 S.C.**



**Canon Zoom Lens
FD 85-300mm
f/4.5 S.S.C.**

Small in size and lightweight, this is a universal zoom lens for shooting scenery and snapshots. Distortions and aberrations are held to the very minimum. Its efficiency, together with fully automatic aperture and fast picture taking functions, lives up to the expectation of people.



Lens Cases

Super Telephoto Lenses

Canon Lens FL 600mm f/5.6



Canon Lens FL 400mm f/5.6



Canon Lens FL 800mm f/8



Canon Focusing Unit



Canon Lens FL 1200mm f/11 S.S.C.

Table of Interchangeable Lenses FD for Canon F-1 and Other Canon SLR Cameras

Type	Lens	Angle of View	Maximum Aperture	Closest Focusing Distance		Filter Size (mm)	Hood	Length		Weight		
				(m)	(ft.)			(mm)	(ins.)	(g)	(lbs.)	(ozs.)
Full Frame Fish-Eye	Fish-Eye FD 15mm f/2.8 S.S.C.	180°	f/16	.3	1	Four Built-in	Built-in	60.5	2-3/8	485	1	1
Super Wide-Angle	FD 17mm f/4 S.S.C.	104°	f/22	25	9	72	None	56	2-3/16	450	1	0
	FD 20mm f/2.8 S.S.C.	94°	f/22	25	9	72	None	58	2-1/4	345		12
	FD 24mm f/2.8 S.S.C.	83°	f/16	.3	1	55	+BW-55B	52.5	2-1/16	330		11-1/2
Wide-Angle	FD 28mm f/3.5 S.C.	75°	f/16	.4	1.5	55	+BW-55B	43	1-11/16	250		9
	*FD 35mm f/2 S.S.C.	64°	f/16	.3	1	55	+BW-55A	50	2-3/8	370		13
	*FD 35mm f/3.5 S.C.	64°	f/16	.4	1.5	55	+BW-55A	49	1-15/16	280		10
Standard	*FD 50mm f/1.4 S.S.C.	46°	f/16	.45	1.5	55	+BS-55	49	1-15/16	305		11
	*FD 50mm f/1.8 S.C.	46°	f/16	.6	2	55	+BS-55	44.5	1-3/4	255		9
	FD 55mm f/1.2 S.C.C.	43°	f/16	.6	2	58	+BS-58	52.5	2-1/16	510	1	2
	FD 55mm f/1.2 AL S.S.C.	43°	f/16	.6	2	58	+BS-58	55	2-3/16	575	1	4
Macro	FD 50mm f/3.5 S.S.C. Macro with Life Size Adapter	46°	f/22	20.5 (cm)	8.4 (ins.)	55	None Necessary	59.5	2-5/16	310		11
Short Telephoto	***FD 85mm f/1.8 S.S.C.	29°	f/22	1	3.5	55	+BT-55			445		15-1/2
	FD 100mm f/2.8 S.S.C.	24°	f/22	1	3.5	55	+BT-55	57	2-1/4	360		12-1/2
Telephoto	FD 135mm f/2.5 S.C.	18°	f/22	1.5	5	58	Built-in	91	3-9/16	630	1	5
	FD 135mm f/3.5 S.C.	18°	f/22	1.5	5	55	+BT-55	83	3-1/4	465	1	0
	FD 200mm f/4 S.S.C.	12°	f/22	2.5	8	55	Built-in	133	5-1/4	675	1	7
	FD 300mm f/5.6 S.C.	8°	f/22	.4	13	58	Built-in	173	6-13/16	1125	2	7-1/2
Zoom	***FD 35-70mm f/2.8-3.5 S.S.C.	64°-31°	f/22	+++ 1	3.5	58	Exclusive	114.5	4-1/2	600	1	5-1/2
	***FD 85-300mm f/4.5 S.S.C.	29°-8°	f/22	2.5	8	Series IX	Built-in	247.5	9-3/4	1940	4	4-1/2
	FD 100-200mm f/5.6 S.C.	24°-12°	f/22	2.5	8	55	Built-in	173	6-13/16	765	1	11

FD Series (For All Operations)

Type	Lens	Angle of View	Minimum Aperture	Closest focusing Distance		Filter Size (mm)	Hood	Length		Weight		
				(m)	(ft.)			(mm)	(ins.)	(g)	(lbs.)	(ozs.)
Circular Fish-Eye	Fish-Eye 7.5mm f/5.6 S.S.C.	180°	f/22	Fixed Focus		Six Built-in	None	62	2-7/16	380		13-1/2
Tilt and Shift	TS 35mm f/2.8 S.S.C.	64°/79°	f/22	.3	1	58	Exclusive	74.5	2-15/16	545	1	3
Bellows Macro	FLM 100mm f/4	24°	f/22	Focusing by Bellows		48	None	43	1-11/16	220		7-1/2
Super Telephoto	**FL 400mm f/5.6	6.2°	f/32	4.5	15	++48	Exclusive	338	1' 1-15/16	3,890	8	9
	**FL 600mm f/5.6	4.1°	f/32	10	35	++48	Built-in	448	1' 5-5/8	5,000	11	0
	**FL 800mm f/8	3.1°	f/32	18	60	++48	Built-in	508	1' 8	5,360	11	13
	**1200mm f/11 S.S.C.	2.1°	f/64	40	130	++48	Built-in	853	3' 3-3/16	6,200	13	11
Artificial Fluorite Telephoto	* FL-F300mm f/2.8 S.S.C. with Extender 2X	8°	f/32	3.5	12	Exclusive Insertion Type	Built-in	231	9-1/16	2,340	5	2
	FL-F 300mm f/5.6	8°	f/22	4	13	58	Built-in	168	6-11/16	850	1	14
	FL-F 500mm f/5.6	5°	f/22	10	33	95	Built-in	300	11-13/16	2,700	5	15

- * Equipped with a coupling pin for Canon Automatic Tuning System.
- ** Front component interchangeable type. Focusing adapter (2 elements, 1 group, FL automatic diaphragm, with A-M ring).
- *** Will be marketed in the near future.
- Available by special order.
- + FD lens hoods are of bayonet mount.
- ++ Filter is of insertion type with holder.
- +++ Macro focusing capability.

Subject to change without notice.

Accessories

■ Canon Bellows FL

A high grade bellows with an automatic aperture coupling mechanism. It is used for macrophotography, from life-size to 3X magnification, with the use of a standard lens. A slide duplicating apparatus can be attached to this bellows.

■ Canon Extension Tubes M

Canon Extension Tubes M make possible easy close-up photography. Manually operated.

■ Canon Bellows M

A handy bellows for macrophotography. This is used to attach a Macro Canon Lens FL 50mm f/3.5 or a Canon Bellows Lens 100mm f/4 to the F-1.



Canon Extension Tubes M

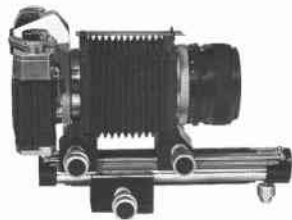

Canon Bellows FL



Canon Bellows M

■ Canon Camera Holder F

The use of the Camera Holder F is recommended for telephotography and slow speed photography. It holds the camera in a stable, center of gravity position, and changing the camera to a horizontal or vertical position can be easily performed. The use of a cable release, at this time, is effective.

■ Canon Release 30, 50

Canon releases of two different length are available.

■ **Close-Up Lenses** (Screw-in Type 48mm, 55mm and 58mm)

Screw diameters for all lenses available. Classified into two kinds of 450 and 240 according to close-up distance.





■ Lens Hood

Always use a lens hood when photographing. It is especially effective when photographing against the light.

With the exception of built-in hoods, all hoods are of the bayonet type. They are attached to the front of the lens by turning clockwise. They can also be stored on the lens in reverse position by turning counterclockwise.

■ Lens Cap

Except for exclusive caps, all caps are of the clip-on type. They are attached on the inner threads of the lens by depressing the knobs on both sides. They can also be attached on double-screw filters.

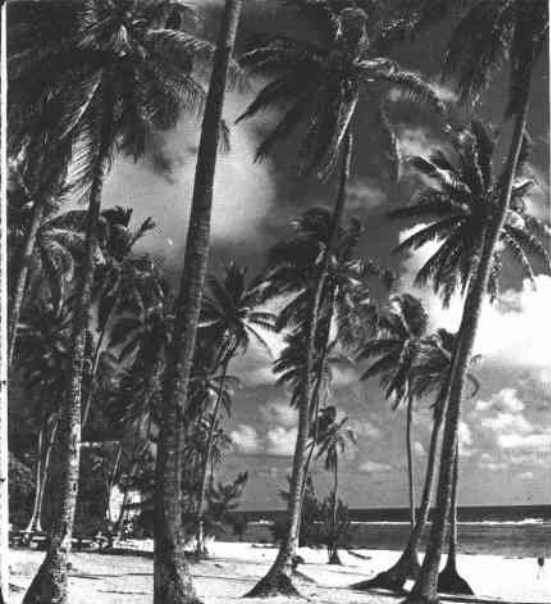

Precautions

1. Perform the interchanging of lenses quickly while avoiding direct sunlight.
2. Be careful not to damage the mount sections, and keep them covered when not in use.
3. Remove dust from the lens surface with a clean, soft brush. Remove stains by lightly wiping with a clean cotton cloth slightly soaked in alcohol. Scratches will result if the lens is wiped with pressure or when dust is still on the lens.
4. Do not keep the lenses in hot or humid places. Use a desiccating agent when storing in a damp place.

Canon

CANON INC. 9-9, Ginza 5-chome, Chuo-ku, Tokyo 104, Japan

U.S.A.

NEW YORK — **CANON U.S.A., INC.**
10 Nevada Drive, Lake Success, Long Island, N.Y. 11040, U.S.A.

CHICAGO — **CANON U.S.A., INC.**
457 Fullerton Avenue, Elmhurst, Illinois 60126, U.S.A.

LOS ANGELES — **CANON OPTICS & BUSINESS MACHINES CO., INC.**
123 Paularino Avenue East, Costa Mesa, California 92626, U.S.A.
CANON OPTICS & BUSINESS MACHINES CO., INC.
3113 Wilshire Blvd., Los Angeles, California 90010, U.S.A.

CANADA

TORONTO — **CANON OPTICS & BUSINESS MACHINES CANADA LTD.**
3245 American Drive, Mississauga, Ontario, L4V 1B8, Canada

MONTREAL — **CANON OFFICE & BUSINESS MACHINES CANADA, LTD.**
3070 Botham Street, St. Laurent Quebec, Canada H4F 1J1

EUROPE, AFRICA
& MIDDLE EAST

AMSTERDAM — **CANON AMSTERDAM N.V.**
Gebouw 70, Schiphol Oost, Holland

CENTRAL &
SOUTH AMERICA

PANAMA — **CANON LATIN AMERICA, INC.**
Apartado 7022, Panamá 5, República de Panamá